



версия
2.0

эксперт
производительности

каталог промышленного инструмента

Продукция изготовлена согласно требованиям ГОСТ, DIN, ISO

токарная обработка

обработка отверстий

фрезерование

нарезание и накатывание резьбы

отрезные работы

зачистка сварных швов

обработка зубчатых и шлицевых соединений

инструментальная и станочная оснастка

измерительный инструмент

средства допускового контроля

слесарно-монтажный инструмент

абразивный инструмент

алмазный инструмент

пневмоинструмент



каталог промышленного инструмента

Продукция изготовлена согласно требованиям ГОСТ, DIN, ISO

Этот каталог с интерактивной навигацией

Содержание



Кликните по номеру страницы в общем содержании, чтобы попасть на нужный раздел

Отрезные работы

Кликните по маркатору сбоку страницы, чтобы вернуться на страницу с содержанием раздела

Обработка зубчатых и шлицевых соединений • Содержание раздела

Главная

Чтобы из содержания раздела вернуться в содержание всего каталога, кликните по слову «Главная» в правом верхнем углу

Токарная обработка

Резцы токарные ГОСТ твердосплавные	22
Отрезные	22
Проходные отогнутые	28
Проходные прямые	34
Проходные упорные изогнутые	46
Проходные упорные прямые	52
Подрезные	58
Расточные	64
Резьбовые	70
Для внутренних канавок	73
Чистовые широкие	76
Расточные цельные со стальным хвостовиком	

Стандарт	ГОСТ 18878-74 Исполнение 2	ГОСТ 18878-74 Исполнение 2
Материал	ВК8	ВК8
Направление	Правые	Левые
Страница	34	35

Интерактивная навигация работает везде, где указан номер страницы

ИНСТУЛС

Российская торговая марка промышленного инструмента и технологической оснастки, изготовленных в строгом соответствии с требованиями отраслевых стандартов. Номенклатура насчитывает более 30 000 наименований, которые поддерживаются в постоянном наличии на складе.

Приоритет ИНСТУЛС — комплексное оснащение российских машиностроительных предприятий качественной продукцией «из одних рук». Это упрощает работу снабжения и обеспечивает бесперебойную работу производственных процессов.

Ассортимент продукции:

-  **обработка отверстий:** сверла, зенкеры, развертки, зенковки
-  **фрезерование:** фрезы концевые, дисковые, фасонные, насадные
-  **отрезные работы:** фрезы отрезные, сегментные пилы, ленточные пилы
-  **нарезание и накатывание резьбы:** метчики, плашки
-  **обработка зубчатых и шлицевых соединений:** долбяки, фрезы дисковые зуборезные, фрезы червячные, протяжки
-  **зачистка сварных швов:** борфрезы

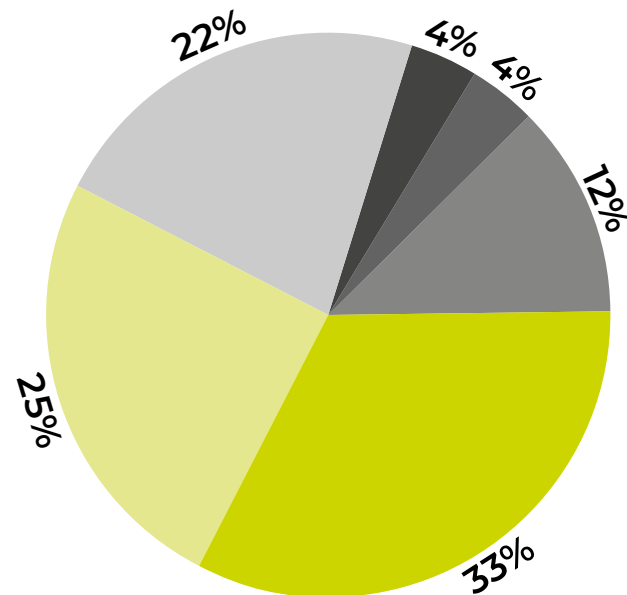

Преимущества инструмента:

- широкая номенклатура с разнообразием диаметров и марок сплавов
- качественные материалы, соответствующие российским ГОСТ
- выходной контроль и металлографическая экспертиза всей продукции
- постоянное наличие на складе РФ
- справедливая стоимость, представленная на открытом инструментальном портале b2b.instrumentgroup.ru/catalog
- оперативная доставка и возможность организации консигнационного склада на предприятии заказчика

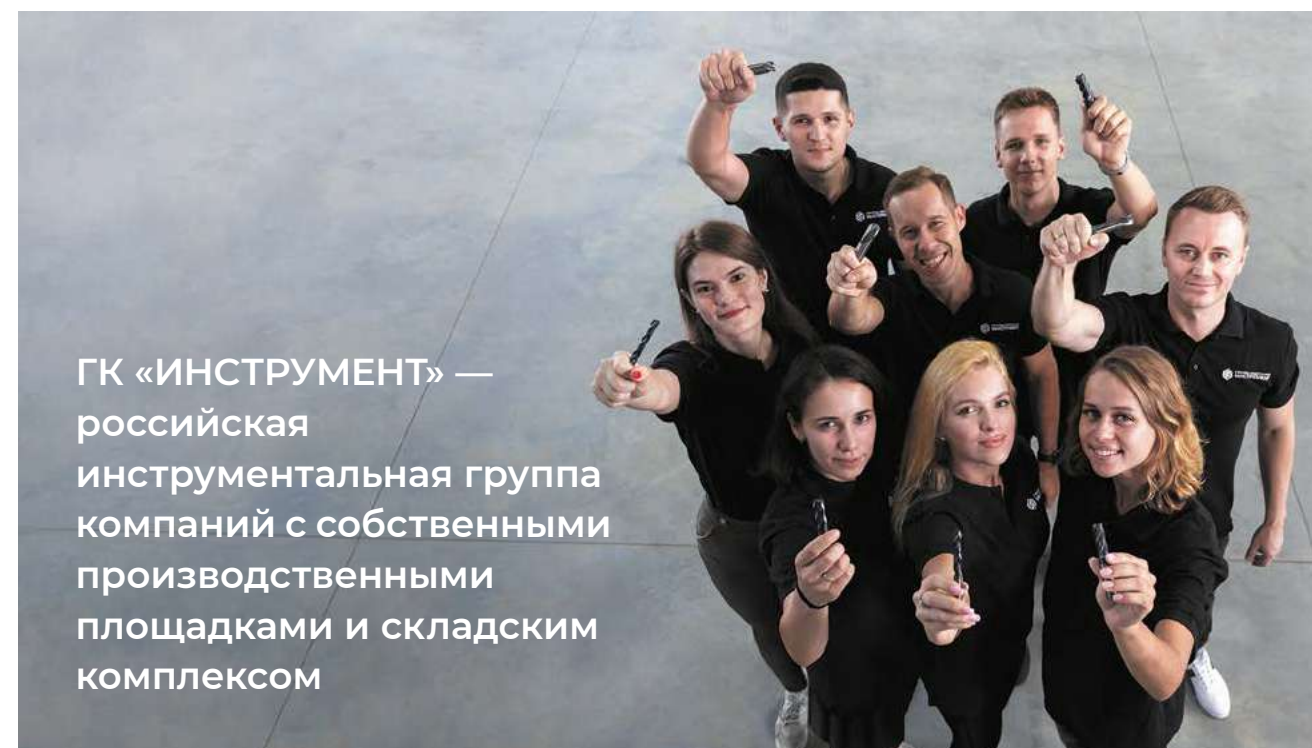

Группа компаний «Инструмент» существует 18 лет. Свой путь компания начинала с оснащения российских машиностроительных предприятий инструментом класса ГОСТ. Накопленный опыт и компетенции позволили нам собрать широкую номенклатуру инструмента, соответствующего строгим отраслевым стандартам, для работы на отечественном и зарубежном оборудовании.

Мы оптимизируем производственные процессы и снабжаем предприятия качественным инструментом. Ведем консультационную и техническую поддержку внедренных технологий. Активно увеличиваем число квалифицированных специалистов в команде, продолжаем развиваться и повышать культуру производства в России!

ГК «Инструмент» сегодня:

-  складской комплекс с постоянным наличием инструмента
-  собственное производство
-  корпоративный университет
-  комплексные поставки
-  охват всех ценовых сегментов
-  инженеринговые проекты



**b2b.instrumentgroup.ru —
цифровой партнер
в обеспечении
предприятия**

B2B ГК «Инструмент» — уникальный цифровой сервис для закупки промышленного инструмента. Позволяет оптимизировать закупочные процессы, превратив их в максимально простую и прозрачную операцию.

Преимущества платформы:

- широкий ассортимент товаров, услуг и производителей
- подбор аналогов в других ценовых сегментах
- точная информация об остатках на складах
- умный подбор связанных товаров
- собственный логистический центр
- возможность для клиентов самостоятельно анализировать закупки
- быстрые поставки в любую точку России
- прямые контракты с поставщиками

2022 год
запуск платформы

>100 000
позиций инструмента

>1 000
зарегистрированных
компаний



Содержание



7

Токарная обработка



113

Обработка отверстий



297

Фрезерование



413

Нарезание и накатывание
резьбы



545

Отрезные работы



577

Зачистка сварных швов



599

Обработка зубчатых
и шлицевых соединений



667

Инструментальная
и станочная оснастка



729

Измерительный
инструмент



761

Средства допускового
контроля



797

Слесарно-монтажный
инструмент



885

Абразивный инструмент



927

Алмазный инструмент



971

Пневмоинструмент

Токарная обработка

Резцы токарные ГОСТ твердосплавные	22
Отрезные	22
Проходные отогнутые	28
Проходные прямые	34
Проходные упорные изогнутые	40
Проходные упорные прямые	46
Подрезные	52
Расточные	58
Резьбовые	64
Для внутренних канавок	70
Чистовые широкие	73
Расточные цельные со стальным хвостовиком	76
Резцы токарные ГОСТ из быстрорежущей стали	78
Отрезные	78
Проходные отогнутые	80
Проходные упорные	82
Проходные упорные изогнутые	84
Подрезные	86
Резьбовые	88
Заготовки	90
Долбежные	91
Пластины сменные	96
Пластины для отрезки и обработки канавок	96
Пластины для токарной обработки	99
Резьбовые пластины	109

Резцы токарные ГОСТ твердосплавные

Токарные резцы используются для обтачивания деталей различной формы на токарном станке. Позволяют обрабатывать наиболее труднодоступные места достаточно сложных по конфигурации деталей. Изготовлены из композитного твердого сплава с содержанием кобальта, что обеспечивает высокую прочность и износостойкость инструмента.



Резцы токарные ГОСТ из быстрорежущей стали

Токарные резцы предназначены для внутреннего точения канавок и профильной обработки, а также для чистового, получистового, черного точения различных материалов. Лезвие из быстрорежущей стали позволяет быстро и легко обрабатывать металл, дерево или пластик, что обеспечивает инструменту высокую прочность и долговечность.



Пластины сменные

Сменные пластины изготовлены из мелкозернистого твердого сплава с PVD-покрытием. Применяются для полустойковой обработки нержавеющей стали, чугуна, титана и жаропрочных сплавов на средних и низких скоростях резания. Основа сплава имеет оптимальное сочетание твердости и прочности, что позволяет вести обработку в условиях как непрерывного, так и прерывистого резания. Отличаются высокой износостойкостью и универсальностью применения.



Условные обозначения

Основные размеры

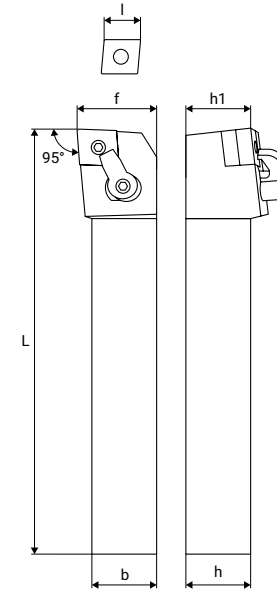

b — ширина хвостовика державки
h — высота хвостовика державки
L — общая длина
f — ширина головки державки
h1 — высота головки державки
l — длина грани пластины

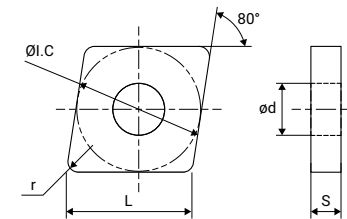

L — длина грани пластины
S — толщина пластины
d — диаметр посадочного отверстия
r — радиус при вершине
Ø LC — диаметр вписанной окружности

Тип обработки



Вид нарезаемой резьбы



Вид обработки

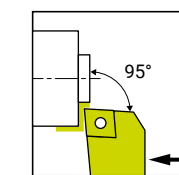

Наличие инструмента

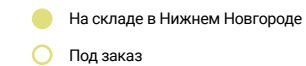

Обрабатываемый материал

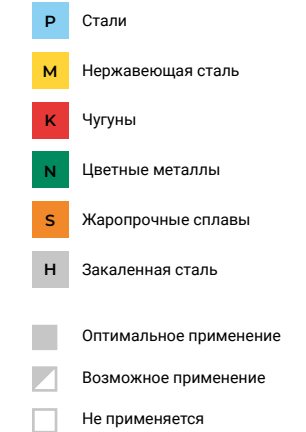

Направление точения

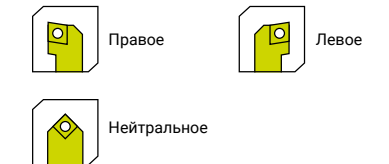

Вид крепления пластины

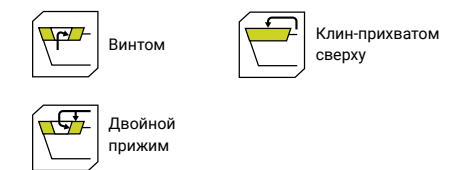

Система обозначений токарных пластин







C		N		M			G	
Форма пластины	Задний угол	Класс точности			Тип пластины			
C Ромбическая 80°	N 0°	Предельное отклонение мм			Конфигурация отверстий	Стружколом		
D Ромбическая 55°	B 5°	d	m	s	A	Цилиндрическое	—	
R Круглая	C 7°	A	± 0,025	± 0,005	± 0,025	B	Цилиндрическое + раззенковка 70-90°	—
S Квадратная 90°	P 11°	C	± 0,025	± 0,013	± 0,025	C	Цилиндрическое + раззенковка 70-90°	—
T Трехгранная 60°	E 20°	E	± 0,025	± 0,025	± 0,025	F	—	двусторонний
V Ромбическая 35°		F	± 0,013	± 0,005	± 0,025	G	Цилиндрическое	двусторонний
W Тригональная 80°		G	± 0,025	± 0,025	± 0,130	H	Цилиндрическое + раззенковка 70-90°	односторонний
		H	± 0,013	± 0,013	± 0,025	J	Цилиндрическое + раззенковка 70-90°	двусторонний
		J	± 0,05-0,15	± 0,005	± 0,025	M	Цилиндрическое	односторонний
		K	± 0,05-0,15	± 0,013	± 0,025	N	—	—
		L	± 0,05-0,15	± 0,025	± 0,025	Q	Цилиндрическое + раззенковка 40-60°	—
		M	± 0,05-0,15	± 0,08-0,20	± 0,130	R	—	односторонний
		N	± 0,05-0,15	± 0,08-0,20	± 0,025	T	Цилиндрическое + раззенковка 40-60°	односторонний
		U	± 0,08-0,25	± 0,13-0,38	± 0,130	U	Цилиндрическое + раззенковка 40-60°	двусторонний
		W				W	Цилиндрическое + раззенковка 40-60°	—
		X				X	специальное исполнение	







12	04	08	M	P
Режущая кромка	Толщина	R при вершине	Вид обработки	Материал (применение)
06 l = 6,350 мм	01 s = 1,59 мм	00 r = max 0,2 мм	F Чистовая обработка	P Сталь
09 l = 9,525 мм	T1 s = 1,98 мм	04 r = 0,4 мм ± 0,1	M Получистовая обработка	M Нержавеющая сталь
11 l = 11,000 мм	02 s = 2,38 мм	08 r = 0,8 мм ± 0,1	R Черновая обработка	K Чугун
12 l = 12,700 мм	T2 s = 2,78 мм	12 r = 1,2 мм ± 0,1	H Тяжелая обработка	N Цветные металлы
15 l = 15,880 мм	03 s = 3,18 мм	16 r = 1,6 мм ± 0,1		U Универсальный
16 l = 16,500 мм	T3 s = 3,97 мм	20 r = 2,0 мм ± 0,1		
19 l = 19,050 мм	04 s = 4,76 мм	25 r = 2,5 мм ± 0,1		
22 l = 22,000 мм	05 s = 5,56 мм	32 r = 3,2 мм ± 0,1		
25 l = 25,400 мм	06 s = 6,35 мм			
	07 s = 7,94 мм			
	09 s = 9,52 мм			

Система обозначений токарных пластин







...	I	C	P	25	0
Особые указания геометрии стружколома	Марка ИНСТУЛС	Материал пластины и покрытие	Область применения	Условия обработки ISO	Поколение сплава
		P Твердый сплав с покрытием PVD	P Сталь	5	0
		C Твердый сплав с покрытием CVD	M Нержавеющая сталь	10	1
		T Кермет с покрытием PVD	K Чугун	15	2
		W Твердый сплав без покрытия	N Алюминий	20	
			S Жаропрочные сплавы	25	
			H Закаленные материалы	30	
			G Общего применения		

Резцы токарные ГОСТ твердосплавные

	Отрезные с пластинами					
Стандарт	ГОСТ 18884-73 Исполнение 2	ГОСТ 18884-73 Исполнение 2	ГОСТ 18884-73 Исполнение 2	ГОСТ 18884-73 Исполнение 2	ГОСТ 18884-73 Исполнение 2	ГОСТ 18884-73 Исполнение 2
Материал	ВК8	ВК8	T15K6	T15K6	T5K10	T5K10
Направление	Правые	Левые	Правые	Левые	Правые	Левые
Страницы	22	23	24	25	26	27
						







	Проходные отогнутые					
Стандарт	ГОСТ 18877-73	ГОСТ 18877-73	ГОСТ 18877-73	ГОСТ 18877-73	ГОСТ 18877-73	ГОСТ 18877-73
Материал	ВК8	ВК8	T15K6	T15K6	T5K10	T5K10
Направление	Правые	Левые	Правые	Левые	Правые	Левые
Страница	28	29	30	31	32	33
						







Резцы токарные ГОСТ твердосплавные

	Проходные прямые					
Стандарт	ГОСТ 18878-74 Исполнение 2	ГОСТ 18878-74 Исполнение 2	ГОСТ 18878-74 Исполнение 2	ГОСТ 18878-74 Исполнение 2	ГОСТ 18878-74 Исполнение 2	ГОСТ 18878-74 Исполнение 2
Материал	ВК8	ВК8	Т15К6	Т15К6	Т5К10	Т5К10
Направление	Правые	Левые	Правые	Левые	Правые	Левые
Страница	34	35	36	37	38	39
						

	Проходные упорные изогнутые					
Стандарт	ГОСТ 18879-73 Тип 2	ГОСТ 18879-73 Тип 2	ГОСТ 18879-73 Тип 2	ГОСТ 18879-73 Тип 2	ГОСТ 18879-73 Тип 2	ГОСТ 18879-73 Тип 2
Материал	ВК8	ВК8	Т15К6	Т15К6	Т5К10	Т5К10
Направление	Правые	Левые	Правые	Левые	Правые	Левые
Страница	40	41	42	43	44	45
						

Резцы токарные ГОСТ твердосплавные

	Проходные упорные прямые					
Стандарт	ГОСТ 18879-73 Тип 1	ГОСТ 18879-73 Тип 1	ГОСТ 18879-73 Тип 1	ГОСТ 18879-73 Тип 1	ГОСТ 18879-73 Тип 1	ГОСТ 18879-73 Тип 1
Материал	ВК8	ВК8	Т15К6	Т15К6	Т5К10	Т5К10
Направление	Правые	Левые	Правые	Левые	Правые	Левые
Страница	46	47	48	49	50	51
						

	Подрезные отогнутые					
Стандарт	ГОСТ 18880-73	ГОСТ 18880-73	ГОСТ 18880-73	ГОСТ 18880-73	ГОСТ 18880-73	ГОСТ 18880-73
Материал	ВК8	ВК8	Т15К6	Т15К6	Т5К10	Т5К10
Направление	Правые	Левые	Правые	Левые	Правые	Левые
Страница	52	53	54	55	56	57
						

Резцы токарные ГОСТ твердосплавные

	Расточные					
Стандарт	ГОСТ 18883-73 ГОСТ 18882-73 Исполнение 1	ГОСТ 18883-73 ГОСТ 18882-73 Исполнение 1	ГОСТ 18883-73 ГОСТ 18882-73 Исполнение 1	ГОСТ 18878-74 Исполнение 2	ГОСТ 18878-74 Исполнение 2	ГОСТ 18878-74 Исполнение 2
Материал	ВК8	ВК8	T15K6	T15K6	T5K10	T5K10
Страница	58	59	60	61	62	63

	Резьбовые с пластинами для наружной метрической резьбы			Резьбовые с пластинами для внутренней метрической резьбы		
Стандарт	ГОСТ 18885-73 Тип 1	ГОСТ 18885-73 Тип 1	ГОСТ 18885-73 Тип 1	ГОСТ 18885-73 Тип 2	ГОСТ 18885-73 Тип 2	ГОСТ 18885-73 Тип 2
Материал	ВК8	T15K6	T5K1012	ВК8	T15K6	T5K1012
Страница	64	65	66	67	68	69

Резцы токарные ГОСТ твердосплавные

	Для внутренних канавок		
Материал	ВК8	T15K6	T5K10
Страница	70	71	72

	Чистовые широкие			Расточные цельные со стальным хвостовиком	
Стандарт	ГОСТ 18881-73	ГОСТ 18881-73	ГОСТ 18881-73	ГОСТ 18063-72 Тип 1 Исполнение 2	ГОСТ 18063-72 Тип 1 Исполнение 2
Материал	ВК8	T15K6	T5K10	ВК6	ВК60М
Страница	73	74	75	76	77

Резцы токарные ГОСТ из быстрорежущей стали

Стандарт	Отрезные		Проходные отогнутые		Проходные упорные	
	ГОСТ 18874-73 Исполнение 1	ГОСТ 18874-73 Исполнение 1	ГОСТ 18868-73	ГОСТ 18868-73	ГОСТ 18870-73 Тип 1 Исполнение 2	ГОСТ 18870-73 Тип 1 Исполнение 2
Материал	P6M5	P6M5	P6M5	P6M5	P6M5	P6M5
Направление	Правые	Левые	Правые	Левые	Правые	Левые
Страница	78	79	80	81	82	83
						

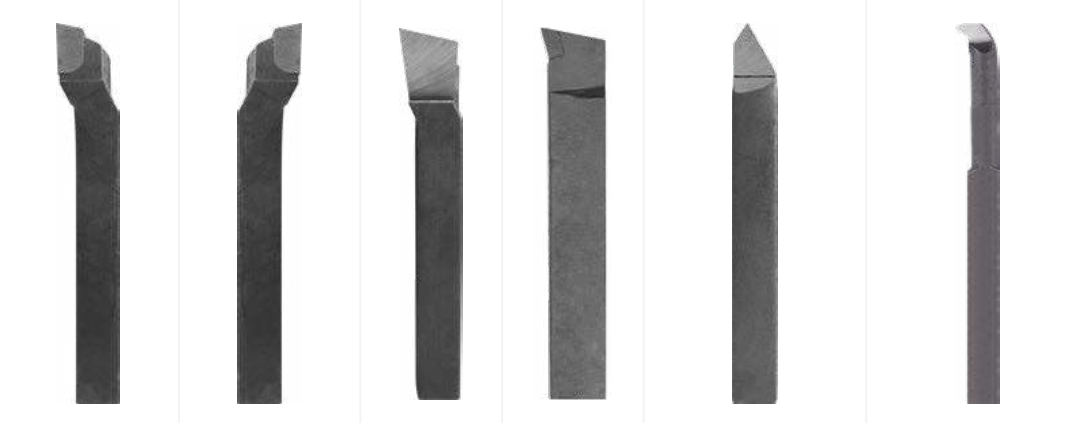
Стандарт	Проходные упорные изогнутые		Подрезные		Резьбовые с пластинами для наружной метрической резьбы	Резьбовые с пластинами для внутренней метрической резьбы
	ГОСТ 18870-73 Тип 2	ГОСТ 18870-73 Тип 2	ГОСТ 18880-73	ГОСТ 18880-73	ГОСТ 18876-73 Тип 1	ГОСТ 18876-73 Тип 2 Исполнение 1
Материал	P6M5	P6M5	P6M5	P6M5	P6M5	P6M5
Направление	Правые	Левые	Правые	Левые	—	—
Страница	84	85	86	87	88	89
						

Резцы токарные ГОСТ из быстрорежущей стали

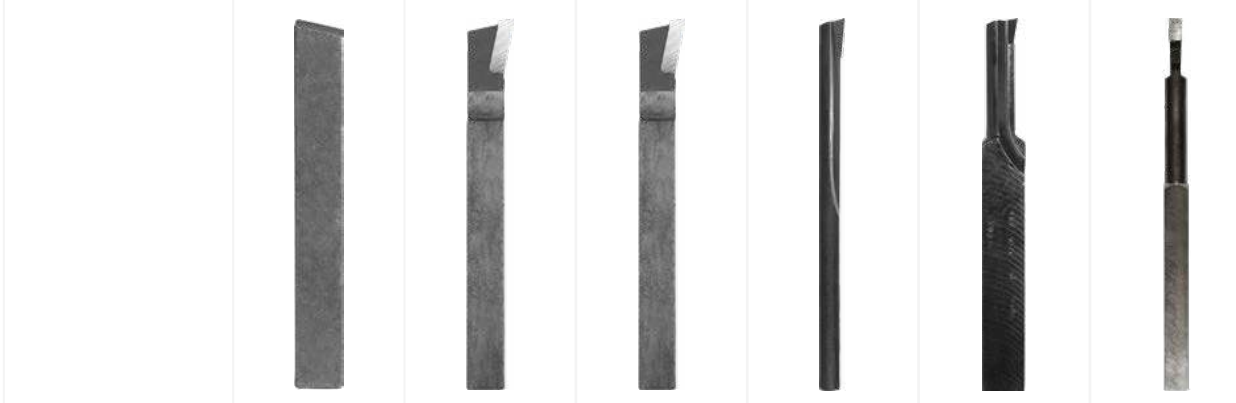
Стандарт	Заготовки	Долбежные				
		ГОСТ 10046-72 Тип 2 Исполнение 1	ГОСТ 10046-72 Тип 2 Исполнение 2	ГОСТ 10046-72 Тип 3 Исполнение 1	ГОСТ 10046-72 Тип 3 Исполнение 2	ГОСТ 10046-72 Тип 3 Исполнение 3
Материал	T15K6	P6M5	P6M5	P6M5	P6M5	P6M5
Направление	Правые	—	—	—	—	—
Страница	90	91	92	93	94	95
						

Пластины сменные

Тип	Для отрезки и обработки канавок		Для наружного точения и профильной обработки
	MGGN/MGMN	MGGN/MGMN	MRMN
Материал	IPG300	IPG300, ITN250, ICP250	IPP250
Страница	96	97	98
			

Пластины сменные

	Для общего точения				
Тип	CNMG	DCMT	DNMG	SCMT	TCMT
Материал	IPG301, ICP250	IPG300	ICP250	IPG300	IPG300
Страница	99	100	101	102	103
					

	Для общего точения				
Тип	TNMG	VBMT	VNMG	WNMG	WNMG
Материал	IPG301, ICP250	IPG300	IPG300, IPG301, ICP250	IPG301, ICP250	IPG301, ICP250
Страница	104	105	106	107	108
					

Резьбовые пластины

	Для нарезания наружной резьбы	Для нарезания внутренней резьбы
Тип	IPP250	IPP250
Резьба	Метрическая М	Метрическая М
Профиль резьбы	Неполный	Неполный
Страница	109	110
		

Резцы отрезные с пластинами из твердого сплава

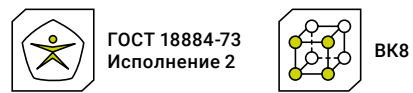

Артикул		h, мм	b, мм	L, мм
1418385	●	12	12	100
1105943	●	16	10	100
1342921	●	16	12	100
1105949	●	20	12	120
1105955	●	20	16	120
1105961	●	25	16	140
1105967	●	25	20	140
1105973	●	32	20	170
1105979	●	40	25	200

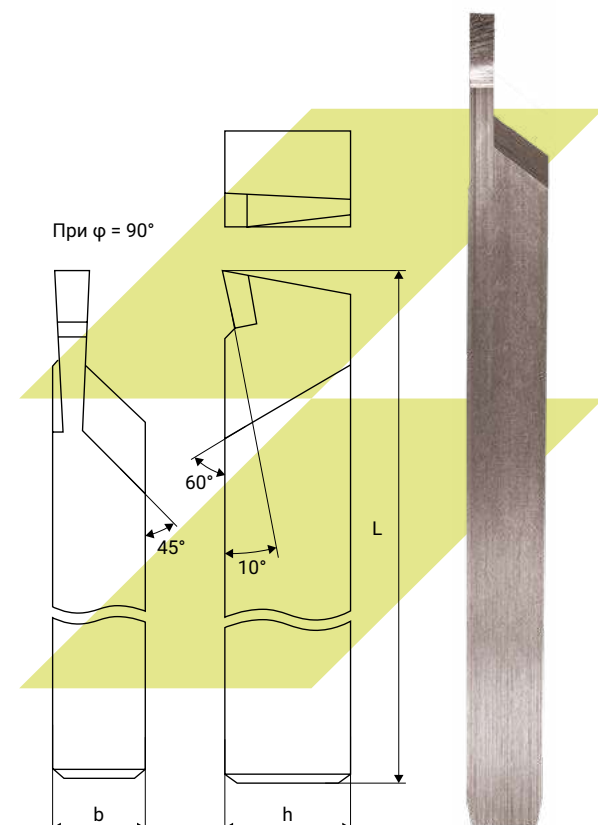

Резцы отрезные с пластинами из твердого сплава

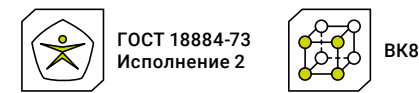

Артикул		h, мм	b, мм	L, мм
1591686	●	12	12	100
1105944	●	16	10	100
1846973	●	16	12	100
1105950	●	20	12	120
1105956	●	20	16	120
1105962	●	25	16	140
1105968	●	25	20	140
1105974	●	32	20	170
1105980	●	40	25	200

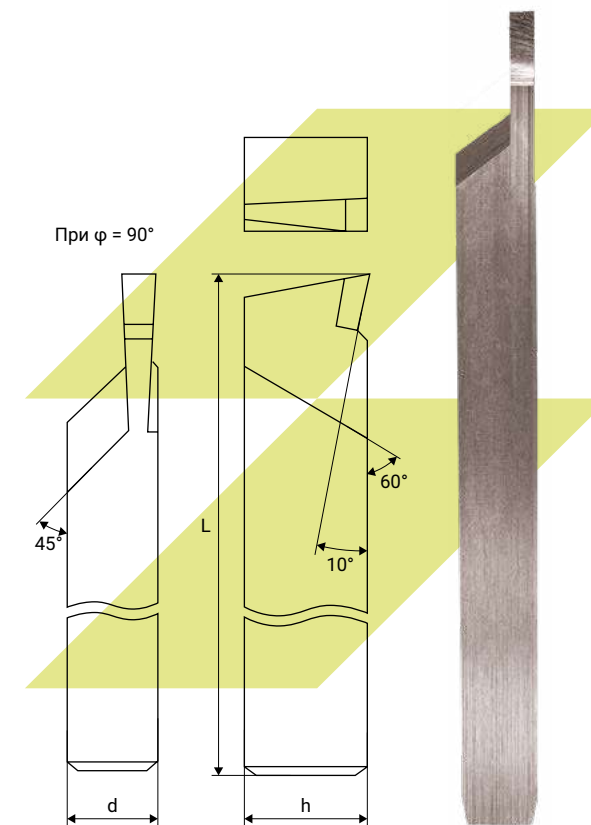

Резцы отрезные с пластинами из твердого сплава

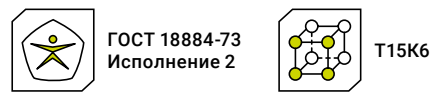

Артикул		h, мм	b, мм	L, мм
1477021	●	12	12	100
1105945	●	16	10	100
1342922	●	16	12	100
1105951	●	20	12	120
1105957	●	20	16	120
1105963	●	25	16	140
1105969	●	25	20	140
1105975	●	32	20	170
1105981	●	40	25	200

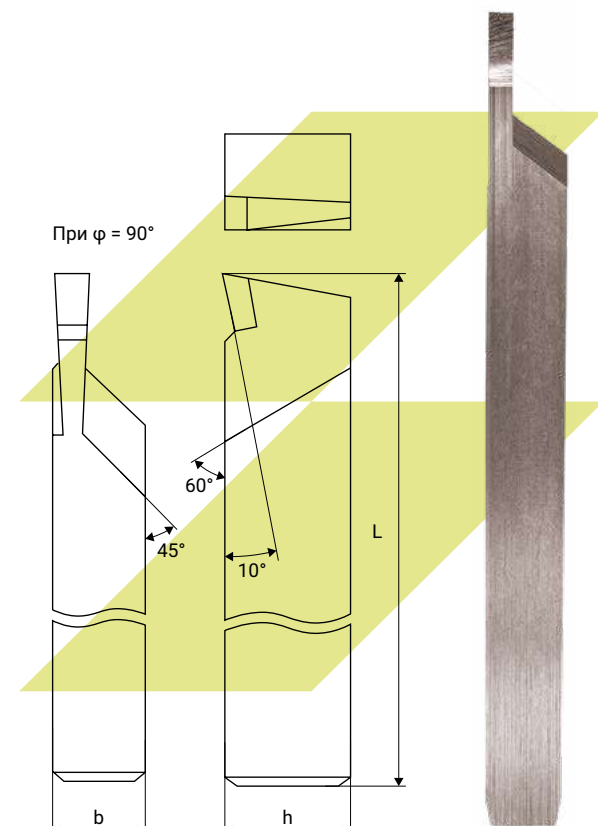

Резцы отрезные с пластинами из твердого сплава

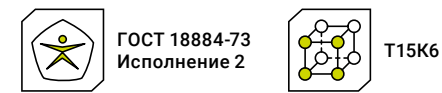

Артикул		h, мм	b, мм	L, мм
1846971	●	12	12	100
1105946	●	16	10	100
1846974	●	16	12	100
1105952	●	20	12	120
1105958	●	20	16	120
1105964	●	25	16	140
1105970	●	25	20	140
1105976	●	32	20	170
1105982	●	40	25	200

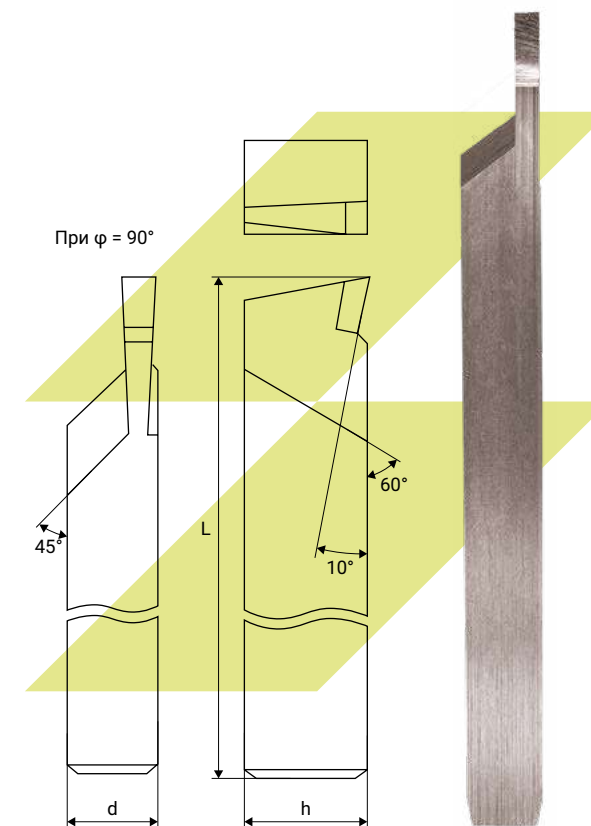

Резцы отрезные с пластинами из твердого сплава

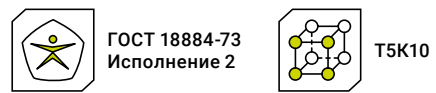

Артикул		h, мм	b, мм	L, мм
1477021	●	12	12	100
1105947	●	16	10	100
1846975	●	16	12	100
1105953	●	20	12	120
1105959	●	20	16	120
1105965	●	25	16	140
1105971	●	25	20	140
1105977	●	32	20	170
1105983	●	40	25	200

Резцы отрезные с пластинами из твердого сплава

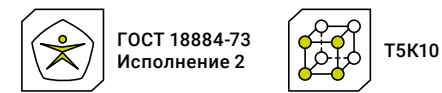

Артикул		h, мм	b, мм	L, мм
1774304	●	12	12	100
1105948	●	16	10	100
1846976	●	16	12	100
1105954	●	20	12	120
1105960	●	20	16	120
1105966	●	25	16	140
1105972	●	25	20	140
1105978	●	32	20	170
1105984	●	40	25	200

При $\varphi = 90^\circ$

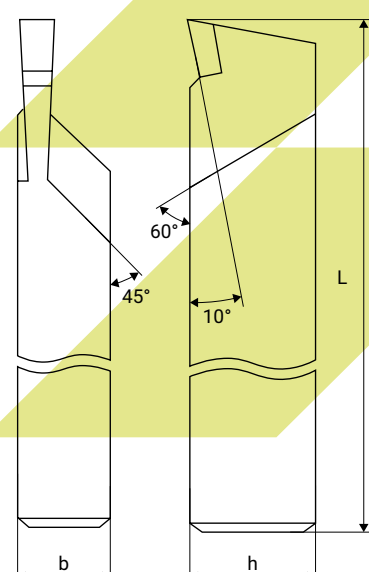

При $\varphi = 90^\circ$

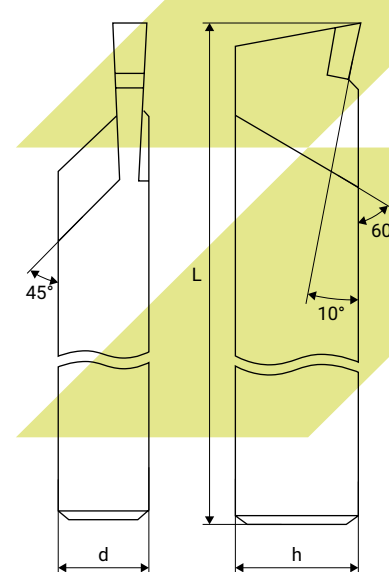

Резцы проходные отогнутые с пластинами из твердого сплава

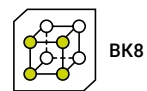

Артикул		Обозначение по ГОСТ		h, мм	b, мм	L, мм
		Угол врезки пластин 10°	Угол врезки пластин 0°			
1106026	●	2102-0021	2102-0071	16	10	110
1130996	●	2102-0023	2102-0073	16	12	100
1377902	●	2102-1106	2102-1108	16	16	110
1106024	●	2102-0025	2102-0075	20	12	125
1106030	●	2102-0027	2102-0077	20	16	120
1417696	●	2102-1111	2102-1113	20	20	125
1106042	●	2102-0029	2102-0079	25	20	170
1106048	●	2102-0009	2102-0059	32	20	170
1106054	●	2102-0031	2102-0081	32	25	170

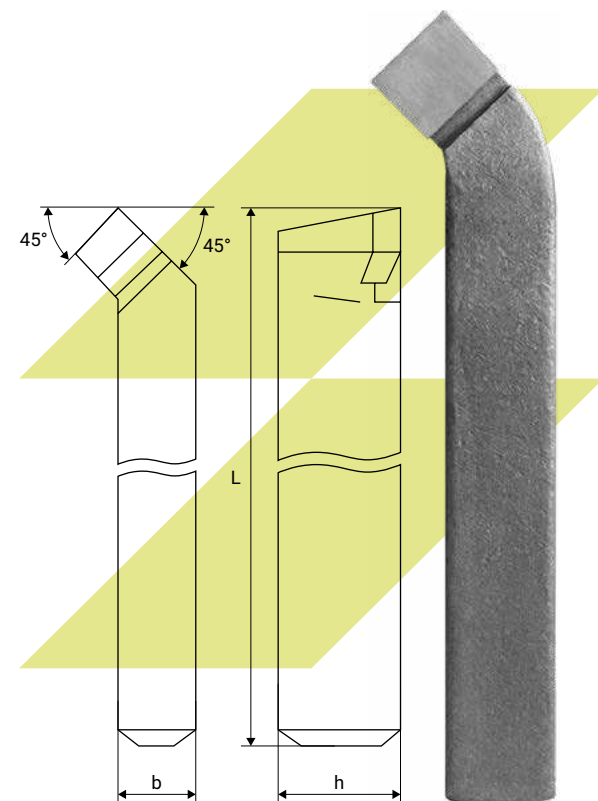

Резцы проходные отогнутые с пластинами из твердого сплава

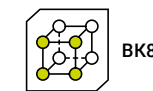

Артикул		Обозначение по ГОСТ		h, мм	b, мм	L, мм
		Угол врезки пластин 10°	Угол врезки пластин 0°			
1150268	●	2102-1103	2102-1105	12	12	100
1751792	●	2102-0022	2102-0072	16	10	110
1591687	●	2102-0024	2102-0074	16	12	100
1846998	●	2102-1107	2102-1109	16	16	110
1751793	●	2102-0026	2102-0076	20	12	125
1847003	●	2102-0028	2102-0078	20	16	120
1106037	●	2102-0006	2102-0056	25	16	140
1106043	●	2102-0030	2102-0080	25	20	170
1106049	●	2102-0010	2102-0060	32	20	170
1106061	●	2102-0014	2102-0064	40	25	200

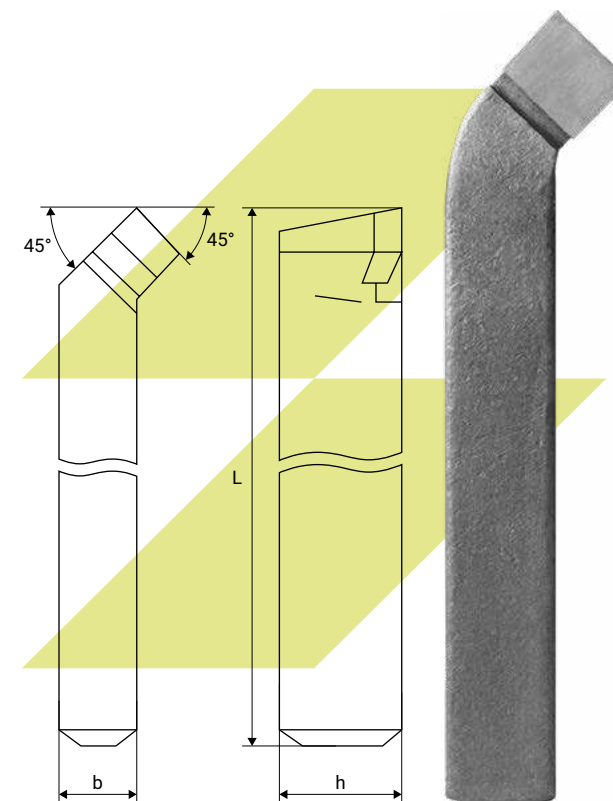

Резцы проходные отогнутые с пластинами из твердого сплава



Артикул		Обозначение по ГОСТ		h, мм	b, мм	L, мм
		Угол врезки пластин 10°	Угол врезки пластин 0°			
1127612	●	2102-0023	2102-0073	16	12	100
1416895	●	2102-1106	2102-1108	16	16	110
1106025	●	2102-0025	2102-0075	20	12	125
1106032	●	2102-0027	2102-0077	20	16	120
1417697	●	2102-1111	2102-1113	20	20	125
1106038	●	2102-0005	2102-0055	25	16	140
1106044	●	2102-0029	2102-0079	25	20	170
1106050	●	2102-0009	2102-0059	32	20	170
1106056	●	2102-0031	2102-0081	32	25	170
1106062	●	2102-0013	2102-0063	40	25	200

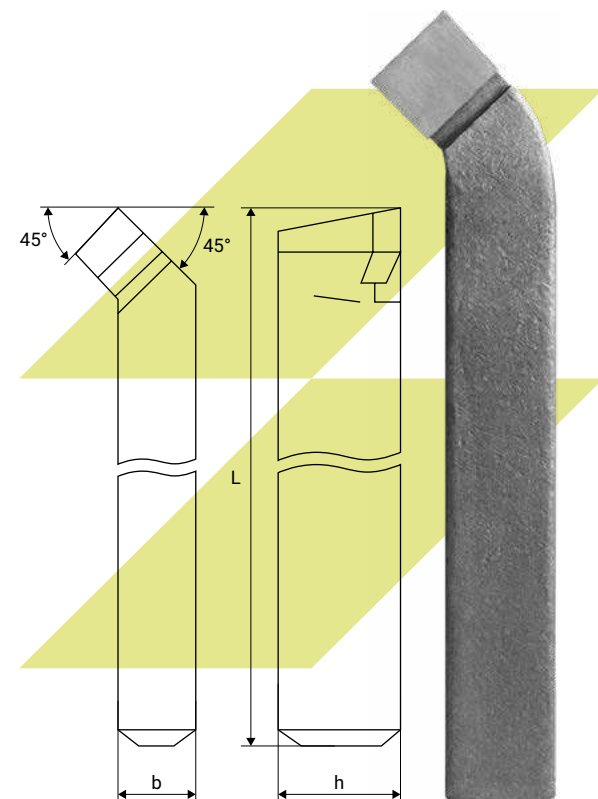

Резцы проходные отогнутые с пластинами из твердого сплава

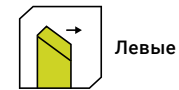
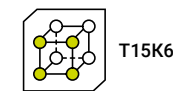

Артикул		Обозначение по ГОСТ		h, мм	b, мм	L, мм
		Угол врезки пластин 10°	Угол врезки пластин 0°			
1150269	●	2102-0022	2102-0072	16	10	110
1846996	●	2102-0024	2102-0074	16	12	100
1846999	●	2102-1107	2102-1109	16	16	110
1847001	●	2102-0026	2102-0076	20	12	125
1106033	●	2102-0028	2102-0078	20	16	120
1847004	●	2102-1112	2102-1114	20	20	125
1106039	●	2102-0006	2102-0056	25	16	140
1106045	●	2102-0030	2102-0080	25	20	170
1106051	●	2102-0010	2102-0060	32	20	170
1106057	●	2102-0032	2102-0082	32	25	170
1106063	●	2102-0014	2102-0064	40	25	200

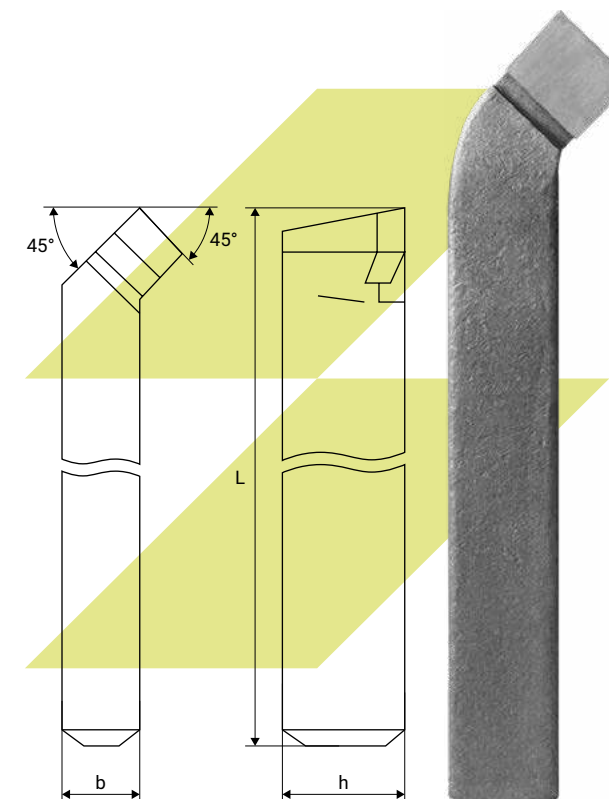

Резцы проходные отогнутые с пластинами из твердого сплава



Артикул		Обозначение по ГОСТ		h, мм	b, мм	L, мм
		Угол врезки пластин 10°	Угол врезки пластин 0°			
1150270	●	2102-1102	2102-1104	12	12	100
1106028	●	2102-0021	2102-0071	16	10	110
1342924	●	2102-0023	2102-0073	16	12	100
1677095	●	2102-1106	2102-1108	16	16	110
1106029	●	2102-0025	2102-0075	20	12	125
1106034	●	2102-0027	2102-0077	20	16	120
1677096	●	2102-1111	2102-1113	20	20	125
1106040	●	2102-0005	2102-0055	25	16	140
1106046	●	2102-0029	2102-0079	25	20	170
1106052	●	2102-0009	2102-0059	32	20	170
1106058	●	2102-0031	2102-0081	32	25	170
1106064	●	2102-0013	2102-0063	40	25	200

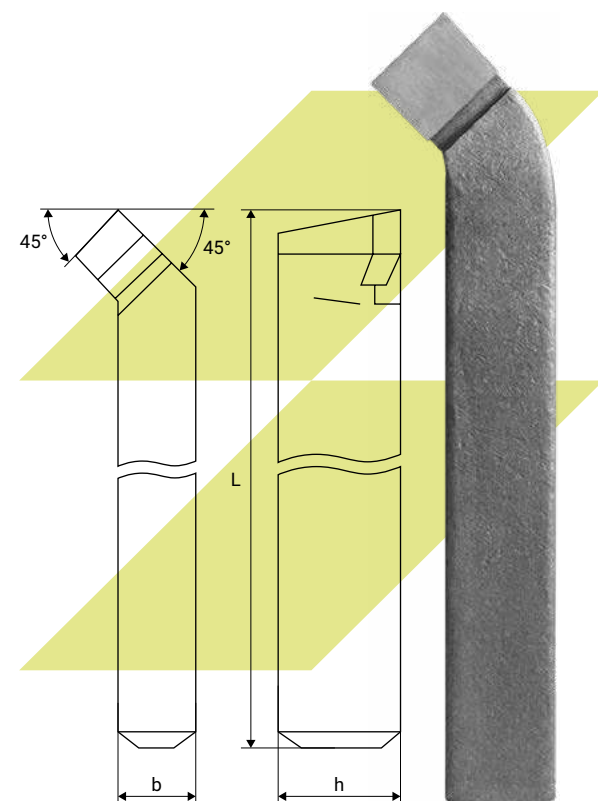

Резцы проходные отогнутые с пластинами из твердого сплава



Артикул		Обозначение по ГОСТ		h, мм	b, мм	L, мм
		Угол врезки пластин 10°	Угол врезки пластин 0°			
1846993	●	2102-1103	2102-1105	12	12	100
1846995	●	2102-0022	2102-0072	16	10	110
1846997	●	2102-0024	2102-0074	16	12	100
1847000	●	2102-1107	2102-1109	16	16	110
1847002	●	2102-0026	2102-0076	20	12	125
1106035	●	2102-0028	2102-0078	20	16	120
1847005	●	2102-1112	2102-1114	20	20	125
1106041	●	2102-0006	2102-0056	25	16	140
1106047	●	2102-0030	2102-0080	25	20	170
1106053	●	2102-0010	2102-0060	32	20	170
1106059	●	2102-0032	2102-0082	32	25	170
1106065	●	2102-0014	2102-0064	40	25	200

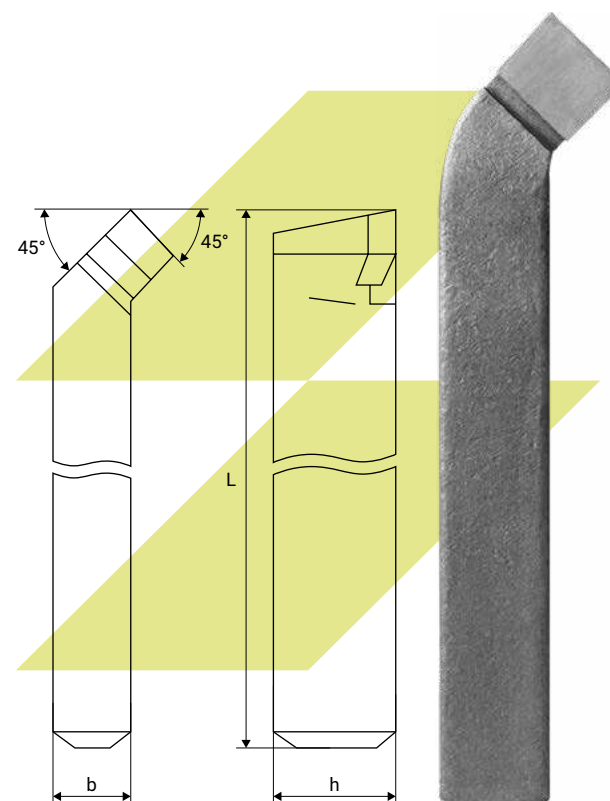

Резцы проходные прямые с пластинами из твердого сплава

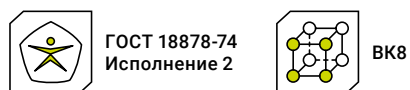

Артикул		Обозначение по ГОСТ		h, мм	b, мм	L, мм
		Угол врезки пластин 10°	Угол врезки пластин 0°			
1326570	●	2100-0005	-	12	12	70
1106108	●	2100-0401	2100-0461	16	10	100
1326212	●	2100-0403	2100-0463	16	12	100
1331027	●	2100-0007	2100-0051	16	16	80
1106066	●	2100-0405	2100-0465	20	12	120
1106072	●	2100-0407	2100-0467	20	16	120
1106078	●	2100-0409	2100-0469	25	16	140
1106084	●	2100-0411	2100-0471	25	20	140
1106090	●	2100-0413	2100-0473	32	20	170
1106096	●	2100-0415	2100-0475	32	25	170
1106102	●	2100-0417	2100-0477	40	25	200

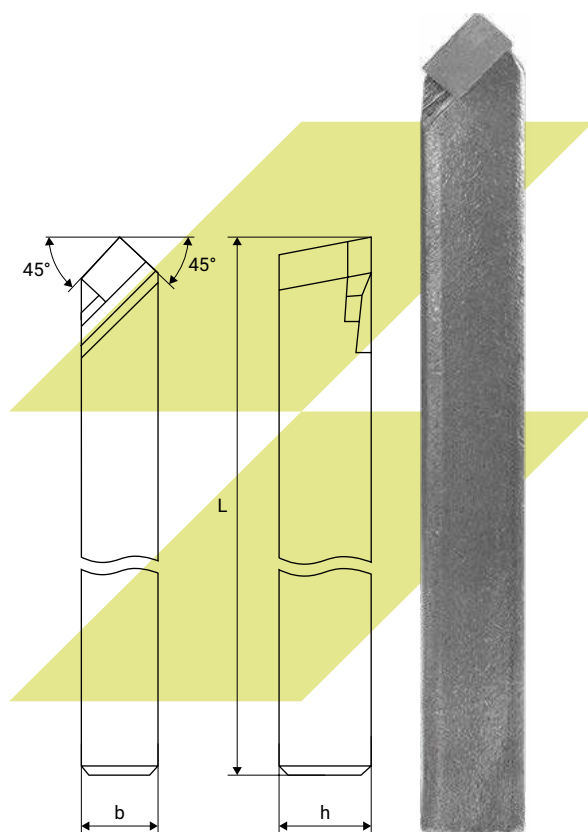

Резцы проходные прямые с пластинами из твердого сплава



Артикул		Обозначение по ГОСТ		h, мм	b, мм	L, мм
		Угол врезки пластин 10°	Угол врезки пластин 0°			
1847007	●	2100-0006	-	12	12	70
1106109	●	2100-0402	2100-0462	16	10	100
1326015	●	2100-0404	2100-0464	16	12	100
1415876	●	2100-0008	2100-0052	16	16	80
1349133	●	2100-0008	2100-0052	16	16	120
1106067	●	2100-0406	2100-0466	20	12	120
1106073	●	2100-0408	2100-0468	20	16	120
1106079	●	2100-0408	2100-0468	25	16	140
1106085	●	2100-0412	2100-0472	25	20	140
1106091	●	2100-0414	2100-0474	32	20	170
1106097	●	2100-0416	2100-0476	32	25	170
1106103	●	2100-0418	2100-0478	40	25	200

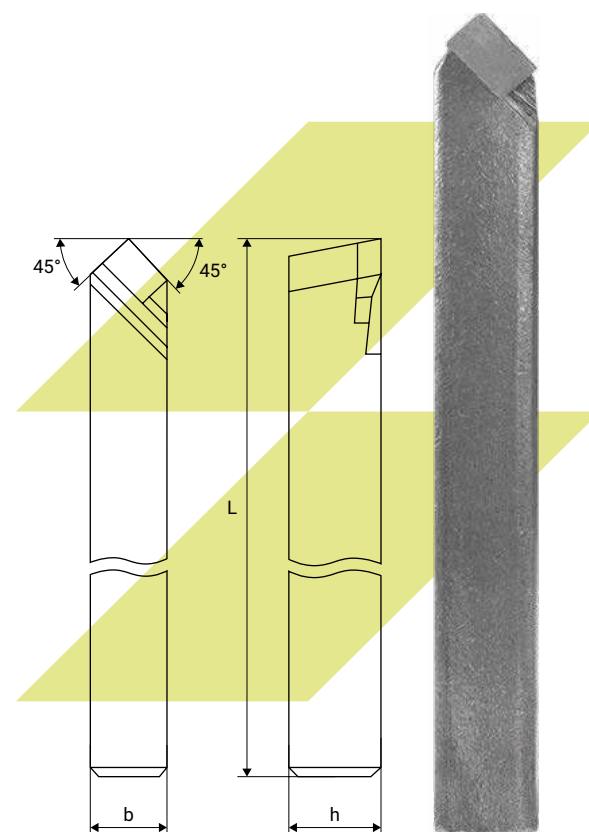

Резцы проходные прямые с пластинами из твердого сплава

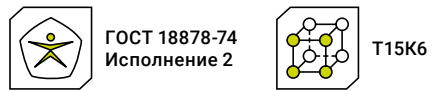

Артикул		Обозначение по ГОСТ		h, мм	b, мм	L, мм
		Угол врезки пластин 10°	Угол врезки пластин 0°			
1425121	●	2100-0003	-	10	10	60
1343404	●	2100-0005	-	12	12	70
1106110	●	2100-0401	2100-0461	16	10	100
1585622	●	2100-0403	2100-0463	16	12	100
1417772	●	2100-0007	2100-0051	16	16	80
1150276	●	2100-0007	2100-0051	16	16	120
1106068	●	2100-0405	2100-0465	20	12	120
1106074	●	2100-0407	2100-0467	20	16	120
1584670	●	2100-0013	2100-0057	20	20	100
1150277	●	2100-0013	2100-0057	20	20	120
1106080	●	2100-0409	2100-0469	25	16	140
1106086	●	2100-0411	2100-0471	25	20	140
1106092	●	2100-0413	2100-0473	32	20	170
1106098	●	2100-0415	2100-0475	32	25	170
1106104	●	2100-0417	2100-0477	40	25	200
1418389	●	2100-0035	2100-0077	40	32	200

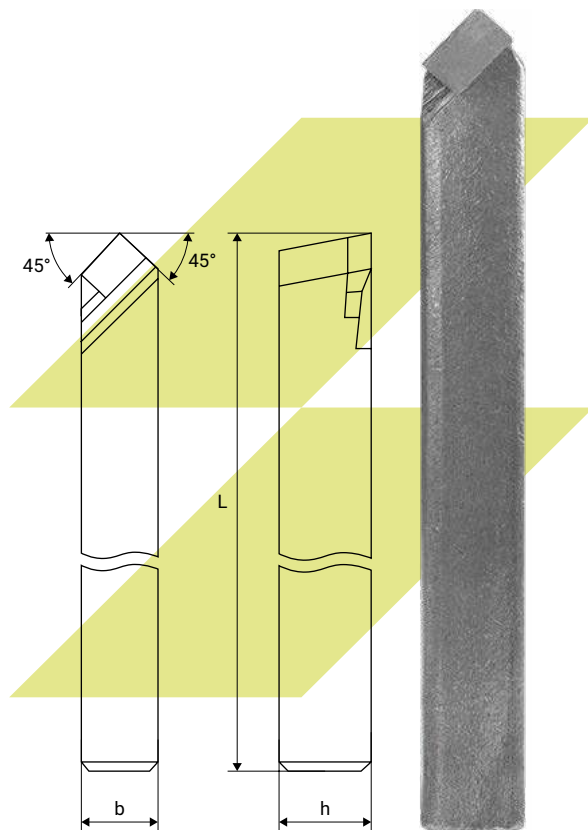

Резцы проходные прямые с пластинами из твердого сплава

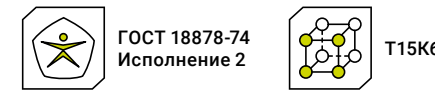

Артикул		Обозначение по ГОСТ		h, мм	b, мм	L, мм
		Угол врезки пластин 10°	Угол врезки пластин 0°			
1847008	●	2100-0006	-	12	12	70
1106111	●	2100-0402	2100-0462	16	10	100
1847010	●	2100-0404	2100-0464	16	12	100
1106069	●	2100-0406	2100-0466	20	12	120
1106075	●	2100-0408	2100-0468	20	16	120
1106081	●	2100-0410	2100-0470	25	16	140
1106087	●	2100-0412	2100-0472	25	20	140
1106093	●	2100-0414	2100-0474	32	20	170
1106099	●	2100-0416	2100-0476	32	25	170
1106105	●	2100-0418	2100-0478	40	25	200

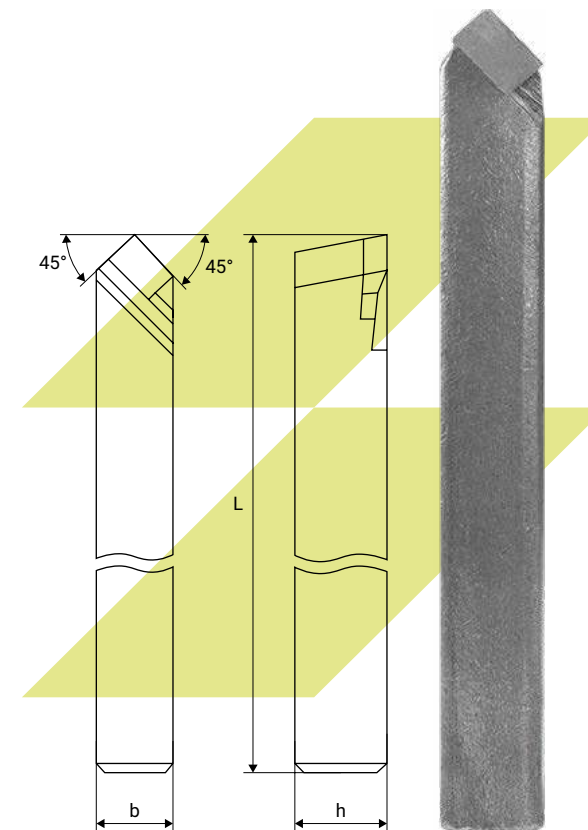

Резцы проходные прямые с пластинами из твердого сплава

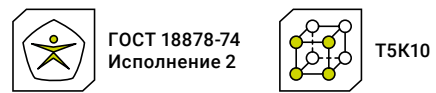

Артикул		Обозначение по ГОСТ		h, мм	b, мм	L, мм
		Угол врезки пластин 10°	Угол врезки пластин 0°			
1330827	●	2100-0005	-	12	12	70
1106112	●	2100-0401	2100-0461	16	10	100
1342947	●	2100-0403	2100-0463	16	12	100
1106070	●	2100-0405	2100-0465	20	12	120
1106076	●	2100-0407	2100-0467	20	16	120
1106082	●	2100-0409	2100-0469	25	16	140
1106088	●	2100-0411	2100-0471	25	20	140
1106094	●	2100-0413	2100-0473	32	20	170
1106100	●	2100-0415	2100-0475	32	25	170
1106106	●	2100-0417	2100-0477	40	25	200

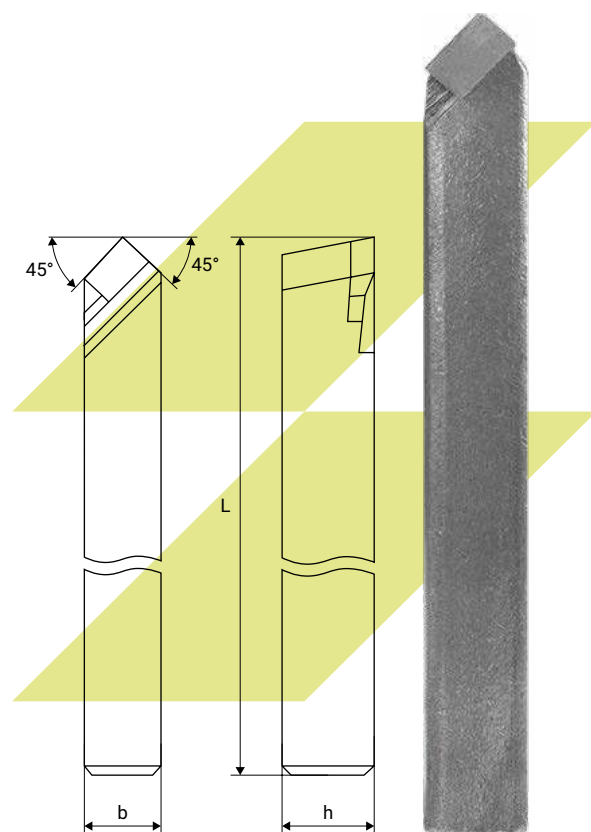

Резцы проходные прямые с пластинами из твердого сплава

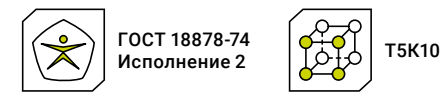

Артикул		Обозначение по ГОСТ		h, мм	b, мм	L, мм
		Угол врезки пластин 10°	Угол врезки пластин 0°			
1847009	●	2100-0006	-	12	12	70
1106113	●	2100-0402	2100-0462	16	10	100
1847011	●	2100-0004	2100-0464	16	12	100
1106071	●	2100-0406	2100-0466	20	12	120
1106077	●	2100-0408	2100-0468	20	16	120
1106083	●	2100-0410	2100-0470	25	16	140
1106089	●	2100-0412	2100-0472	25	20	140
1106095	●	2100-0414	2100-0474	32	20	170
1106101	●	2100-0416	2100-0476	32	25	170
1106107	●	2100-0418	2100-0478	40	25	200

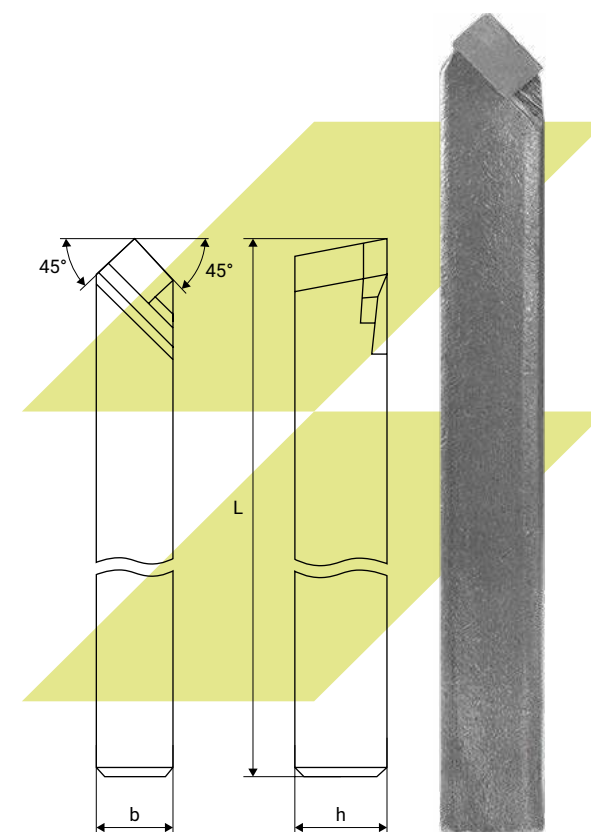

Резцы проходные упорные изогнутые с пластинами из твердого сплава

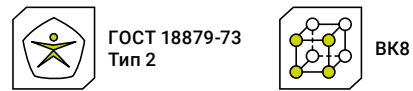

Артикул	Обозначение по ГОСТ		h, мм	b, мм	L, мм
	Угол врезки пластин 10°	Угол врезки пластин 0°			
1729378	2103-1103	2103-1123	12	12	100
1106114	2103-0017	2103-0067	16	10	110
1127615	2103-0019	2103-0069	16	12	100
1477053	2103-1105	2103-1125	16	16	110
1106117	2103-0003	2103-0053	20	12	120
1106120	2103-0021	2103-0071	20	16	120
1847028	2103-1107	2103-1127	20	20	125
1106126	2103-0007	2103-0057	25	16	140
1106132	2103-0023	2103-0073	25	20	140
1106138	2103-0009	2103-0059	32	20	170
1265292	2103-0025	2103-0075	32	25	170
1106144	2103-0011	2103-0061	40	25	200

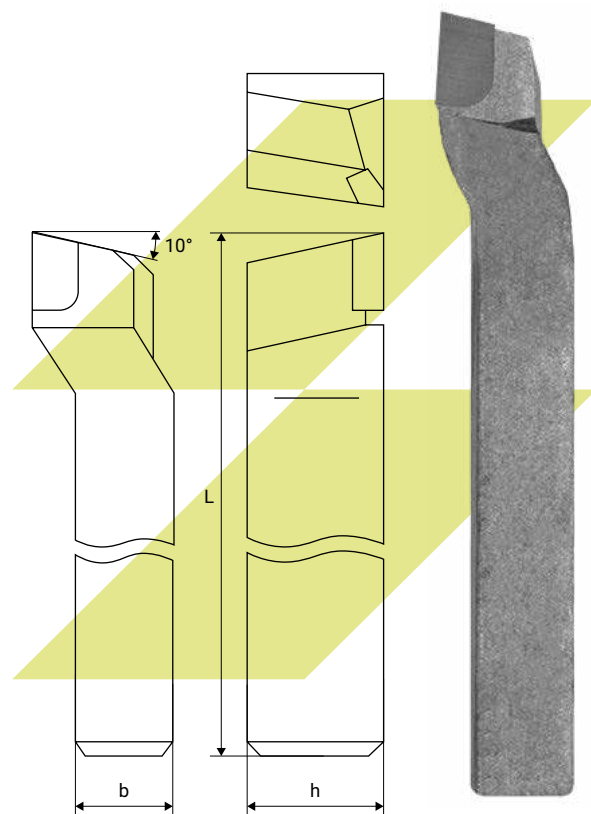

Резцы проходные упорные изогнутые с пластинами из твердого сплава

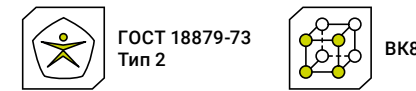

Артикул	Обозначение по ГОСТ		h, мм	b, мм	L, мм
	Угол врезки пластин 10°	Угол врезки пластин 0°			
1847014	2103-1104	2103-1124	12	12	100
1847018	2103-0017	2103-0067	16	10	110
1847021	2103-0020	2103-0070	16	12	100
1847023	2103-1106	2103-1126	16	16	110
1147038	-	-	20	12	120
1106121	2103-0022	2103-0072	20	16	120
1847029	2103-1108	2103-1128	20	20	125
1106127	2103-0008	2103-0058	25	16	140
1106133	2103-0024	2103-0074	25	20	140
1106139	2103-0010	2103-0060	32	20	170
1265291	2103-0026	2103-0076	32	25	170
1106145	2103-0012	2103-0062	40	25	200

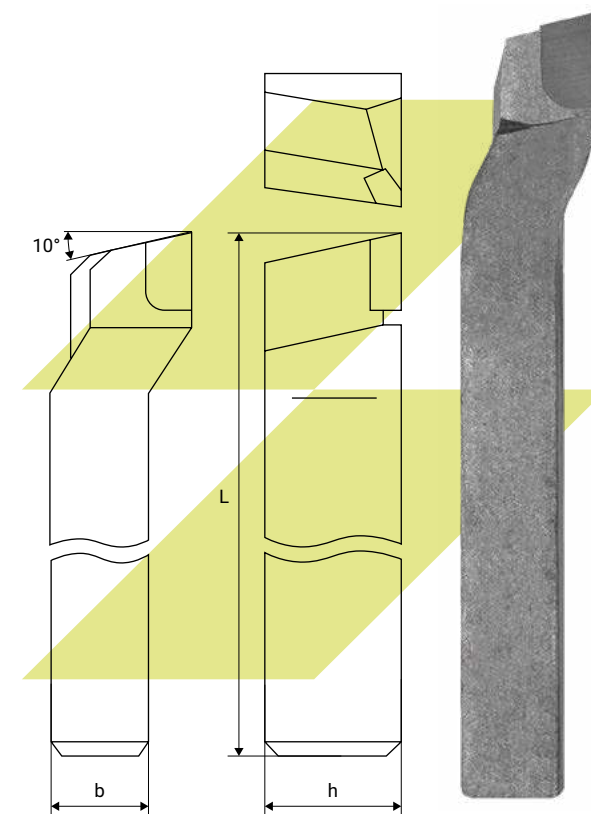

Резцы проходные упорные изогнутые с пластинами из твердого сплава

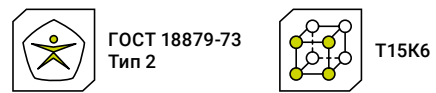

Артикул	Обозначение по ГОСТ		h, мм	b, мм	L, мм
	Угол врезки пластин 10°	Угол врезки пластин 0°			
1634710	2103-1103	2103-1123	12	12	100
1106115	2103-0017	2103-0067	16	10	110
1150284	2103-0019	2103-0069	16	12	100
1150286	2103-1105	2103-1125	16	16	110
1106118	2103-0003	2103-0053	20	12	120
1106122	2103-0021	2103-0071	20	16	120
1477046	2103-1107	2103-1127	20	20	125
1106128	2103-0007	2103-0057	25	16	140
1106134	2103-0023	2103-0073	25	20	140
1106140	2103-0009	2103-0059	32	20	170
1584954	2103-0025	2103-0075	32	25	170
1106146	2103-0011	2103-0061	40	25	200

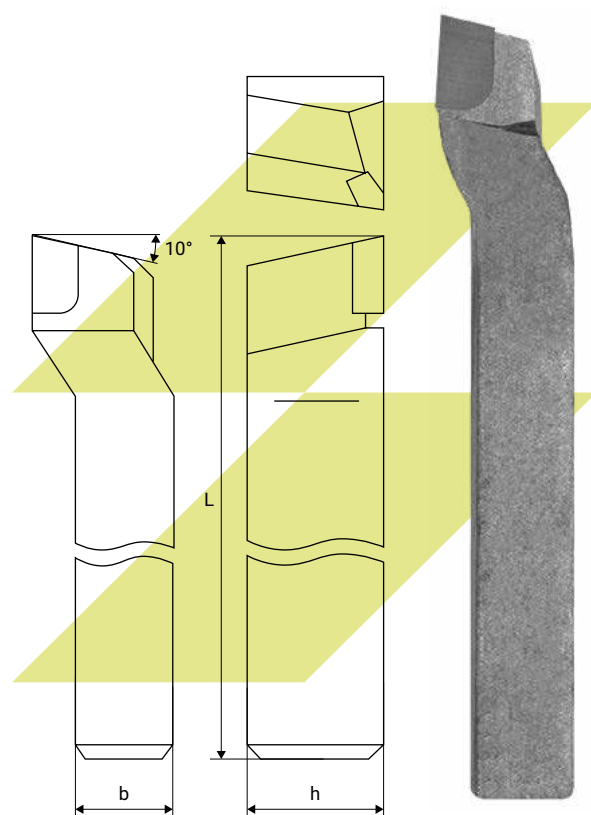

Резцы проходные упорные изогнутые с пластинами из твердого сплава

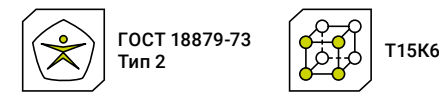

Артикул	Обозначение по ГОСТ		h, мм	b, мм	L, мм
	Угол врезки пластин 10°	Угол врезки пластин 0°			
1847015	2103-1104	2103-1124	12	12	100
1847019	2103-0018	2103-0068	16	10	110
1335639	2103-0020	2103-0070	16	12	100
1847024	2103-1106	2103-1126	16	16	110
1847026	2103-0004	2103-0054	20	12	120
1106123	2103-0022	2103-0072	20	16	120
1847030	2103-1108	2103-1128	20	20	125
1106129	2103-0008	2103-0058	25	16	140
1106135	2103-0024	2103-0074	25	20	140
1106141	2103-0010	2103-0060	32	20	170
1847031	2103-0026	2103-0076	32	25	170
1106147	2103-0012	2103-0062	40	25	200

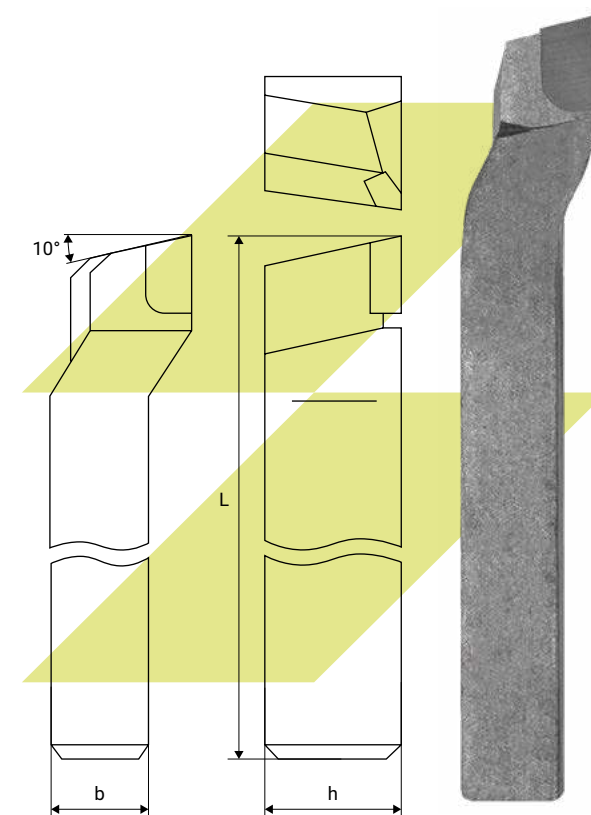

Резцы проходные упорные изогнутые с пластинами из твердого сплава

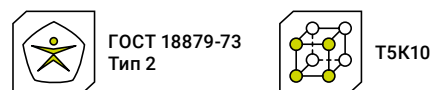

Артикул		Обозначение по ГОСТ		h, мм	b, мм	L, мм
		Угол врезки пластин 10°	Угол врезки пластин 0°			
1847016	●	2103-1103	2103-1123	12	12	100
1106116	●	2103-0017	2103-0067	16	10	110
1415877	●	2103-0019	2103-0069	16	12	100
1582540	●	2103-1105	2103-1125	16	16	110
1106119	●	2103-0003	2103-0053	20	12	120
1106124	●	2103-0021	2103-0071	20	16	120
1417698	●	2103-1107	2103-1127	20	20	125
1106130	●	2103-0007	2103-0057	25	16	140
1106136	●	2103-0023	2103-0073	25	20	140
1106142	●	2103-0009	2103-0059	32	20	170
1343347	●	2103-0025	2103-0075	32	25	170
1106148	●	2103-0011	2103-0061	40	25	200

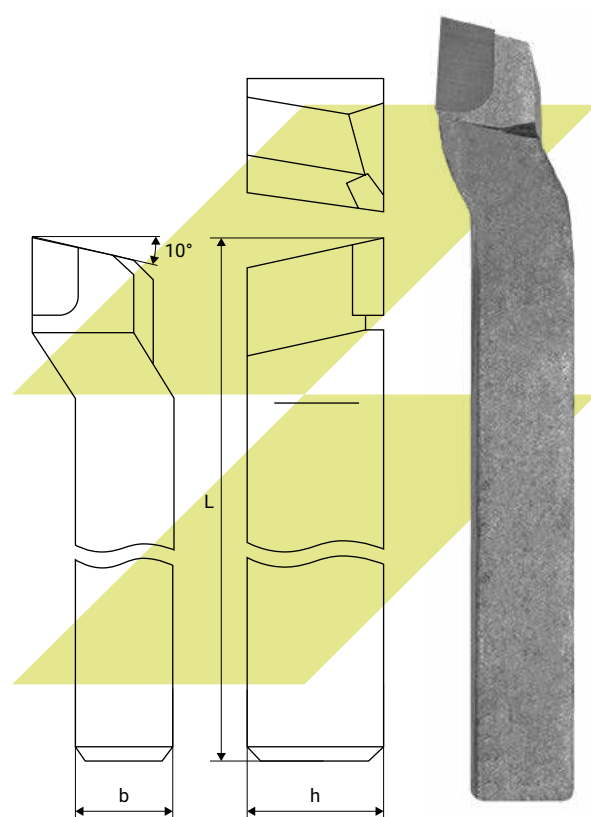

Резцы проходные упорные изогнутые с пластинами из твердого сплава

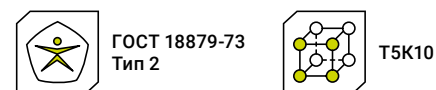

Артикул		Обозначение по ГОСТ		h, мм	b, мм	L, мм
		Угол врезки пластин 10°	Угол врезки пластин 0°			
1847017	●	2103-1104	2103-1124	12	12	100
1847020	●	2103-0018	2103-0068	16	10	110
1847022	●	2103-0020	2103-0070	16	12	100
1847025	●	2103-1106	2103-1126	16	16	110
1847027	●	2103-0004	2103-0054	20	12	120
1106125	●	2103-0022	2103-0072	20	16	120
1417699	●	2103-1108	2103-1128	20	20	125
1106131	●	2103-0008	2103-0058	25	16	140
1106137	●	2103-0024	2103-0074	25	20	140
1106143	●	2103-0010	2103-0060	32	20	170
1416403	●	2103-0026	2103-0076	32	25	170
1106149	●	2103-0012	2103-0062	40	25	200

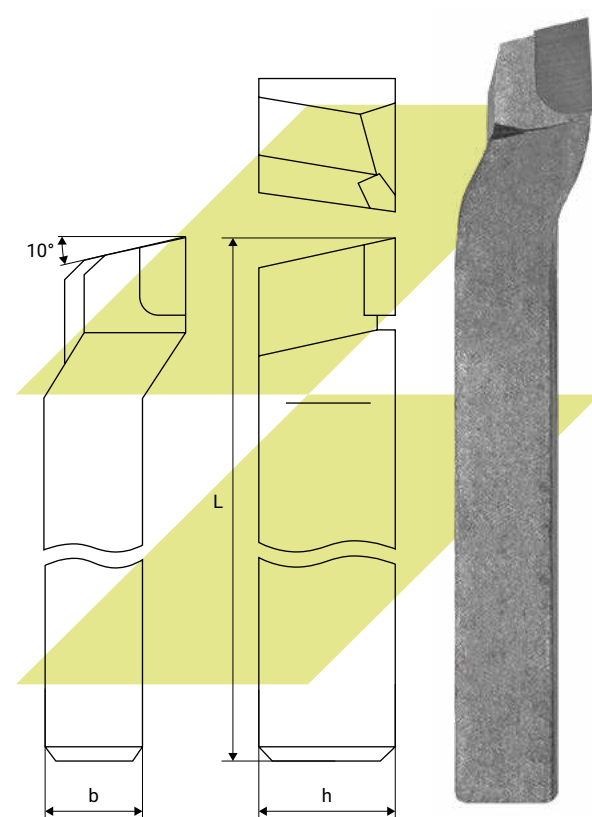

Резцы проходные упорные прямые с пластинами из твердого сплава

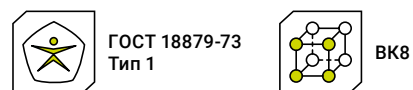

Артикул		Обозначение по ГОСТ		h, мм	b, мм	L, мм
		Угол врезки пластин 10°	Угол врезки пластин 0°			
1409743	●	2101-0005	-	12	12	70
1106153	●	-	-	16	10	100
1847036	●	-	-	16	12	100
1342882	●	2101-0007	2101-0051	16	16	80
1106150	●	2101-0009	2101-0053	20	12	100
1106156	●	-	-	20	16	120
1378735	●	2101-0011	2101-0055	20	20	100
1106168	●	2101-0013	2101-0057	25	16	120
1106162	●	-	-	25	20	140
1531144	●	-	-	25	25	120
1265298	●	2101-0015	2101-0059	32	20	140
1106180	●	-	-	32	25	170

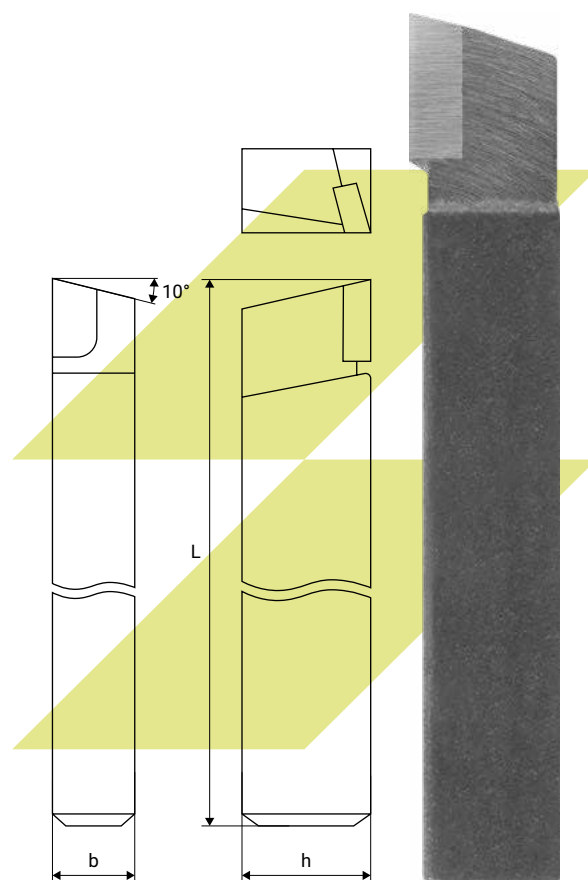

Резцы проходные упорные прямые с пластинами из твердого сплава

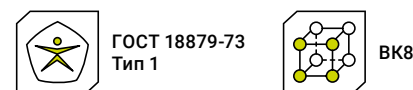

Артикул		Обозначение по ГОСТ		h, мм	b, мм	L, мм
		Угол врезки пластин 10°	Угол врезки пластин 0°			
1477054	●	2101-0006	-	12	12	70
1477055	●	-	-	16	10	100
1847037	●	-	-	16	12	100
1378173	●	2101-0008	2101-0052	16	16	80
1150629	●	2101-0010	2101-0054	20	12	100
1106157	●	-	-	20	16	120
1847047	●	2101-0012	2101-0056	20	20	100
1106169	●	2101-0014	2101-0058	25	16	120
1106163	●	-	-	25	20	140
1289549	●	2101-0016	2101-0060	32	20	140
1106181	●	-	-	32	25	170

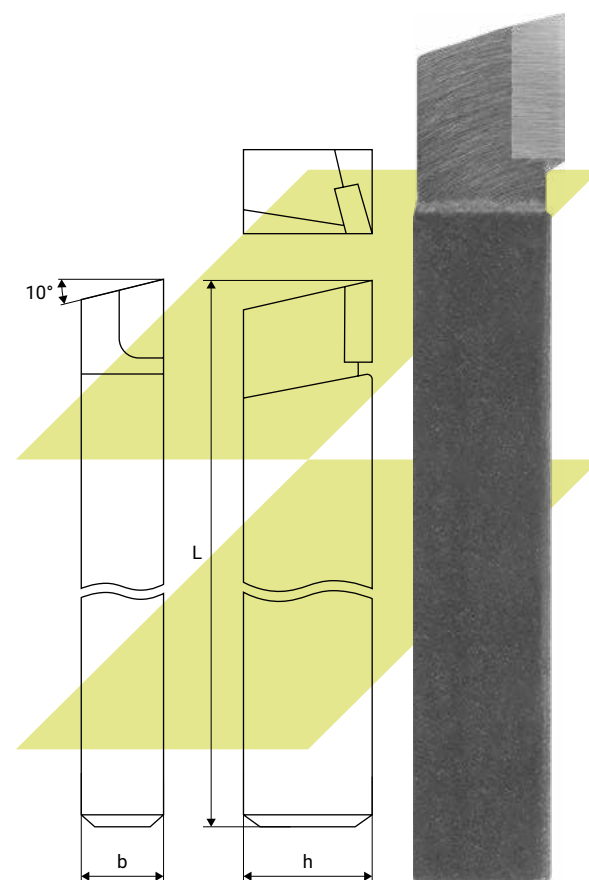

Резцы проходные упорные прямые с пластинами из твердого сплава

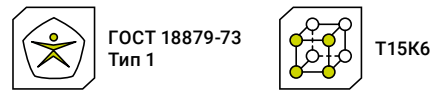

Артикул		Обозначение по ГОСТ		h, мм	b, мм	L, мм
		Угол врезки пластин 10°	Угол врезки пластин 0°			
1377376	●	2101-0005	-	12	12	70
1106154	●	-	-	16	10	100
1847038	●	-	-	16	12	100
1287144	●	2101-0007	2101-0051	16	16	80
1106151	●	2101-0009	2101-0053	20	12	100
1106158	●	-	-	20	16	120
1415824	●	2101-0011	2101-0055	20	20	100
1106170	●	2101-0013	2101-0057	25	16	120
1106164	●	-	-	25	20	140
1289550	●	2101-0015	2101-0059	32	20	140
1106182	●	-	-	32	25	170

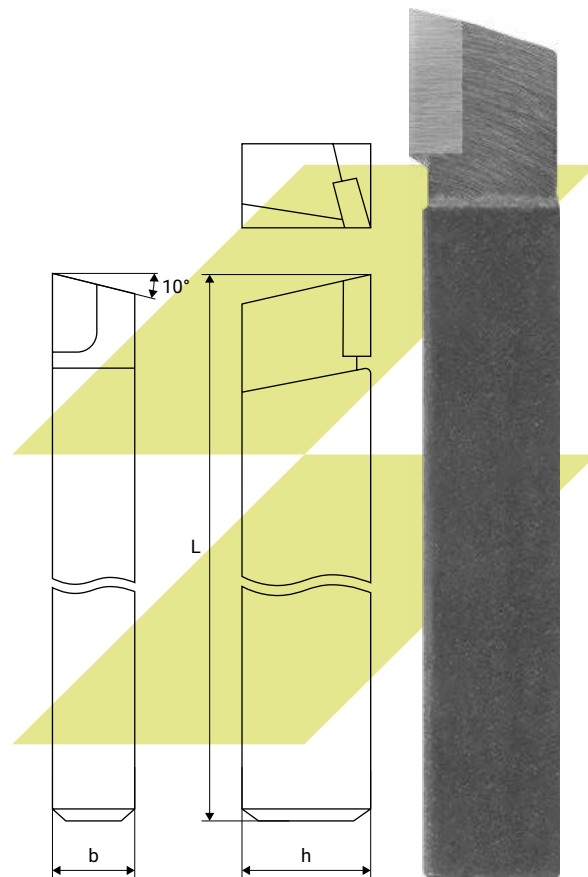

Резцы проходные упорные прямые с пластинами из твердого сплава

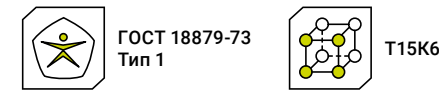

Артикул		Обозначение по ГОСТ		h, мм	b, мм	L, мм
		Угол врезки пластин 10°	Угол врезки пластин 0°			
1584977	●	2101-0006	-	12	12	70
1847034	●	-	-	16	10	100
1847039	●	-	-	16	12	100
1847043	●	2101-0008	2101-0052	16	16	80
1150288	●	2101-0010	2101-0054	20	12	100
1106159	●	-	-	20	16	120
1847048	●	2101-0012	2101-0056	20	20	100
1106171	●	2101-0014	2101-0058	25	16	120
1106165	●	-	-	25	20	140
1289551	●	2101-0016	2101-0060	32	20	140
1106183	●	-	-	32	25	170

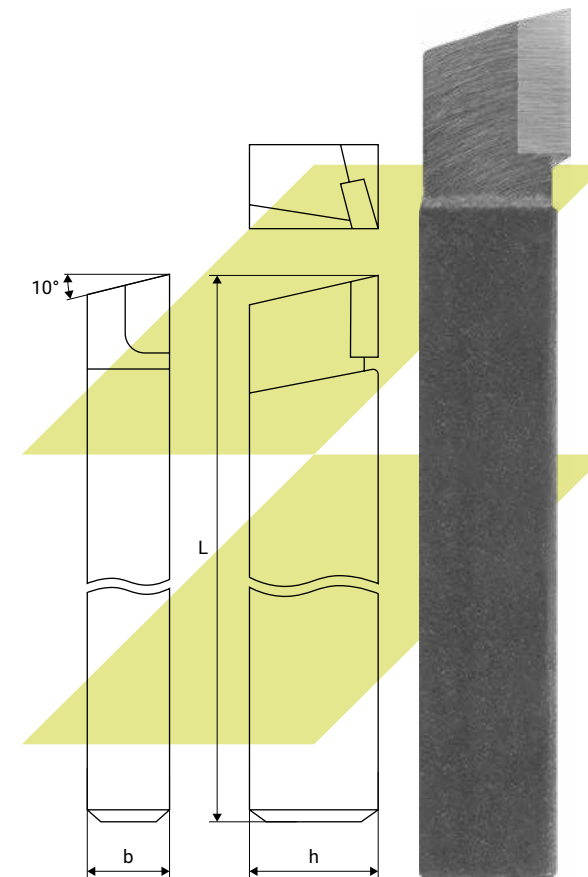

Резцы проходные упорные прямые с пластинами из твердого сплава

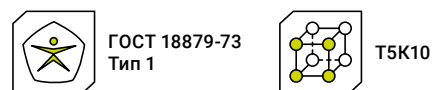

Артикул		Обозначение по ГОСТ		h, мм	b, мм	L, мм
		Угол врезки пластин 10°	Угол врезки пластин 0°			
1378554	●	2101-0005	-	12	12	70
1106155	●	-	-	16	10	100
1847040	●	-	-	16	12	100
1342883	●	2101-0007	2101-0051	16	16	80
1106152	●	2101-0009	2101-0053	20	12	100
1106160	●	-	-	20	16	120
1425551	●	2101-0011	2101-0055	20	20	100
1106172	●	2101-0013	2101-0057	25	16	120
1106166	●	-	-	25	20	140
1289552	●	2101-0015	2101-0059	32	20	140
1106184	●	-	-	32	25	170

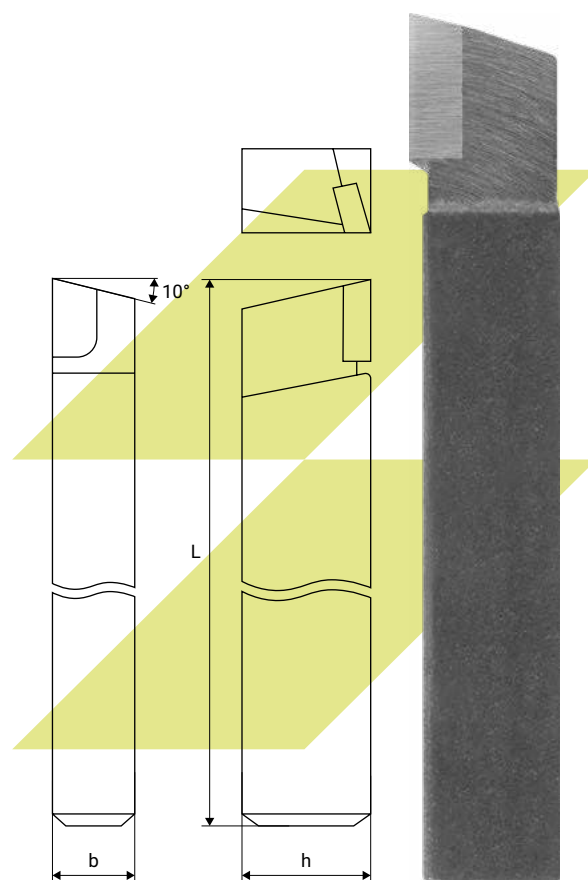

Резцы проходные упорные прямые с пластинами из твердого сплава

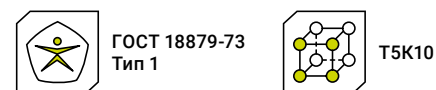

Артикул		Обозначение по ГОСТ		h, мм	b, мм	L, мм
		Угол врезки пластин 10°	Угол врезки пластин 0°			
1847033	●	2101-0006	-	12	12	70
1847035	●	-	-	16	10	100
1847041	●	-	-	16	12	100
1847044	●	2101-0008	2101-0052	16	16	80
1425532	●	2101-0010	2101-0054	20	12	100
1106161	●	-	-	20	16	120
1847049	●	2101-0012	2101-0056	20	20	100
1106173	●	2101-0014	2101-0058	25	16	120
1106167	●	-	-	25	20	140
1289553	●	2101-0016	2101-0060	32	20	140
1106185	●	-	-	32	25	170

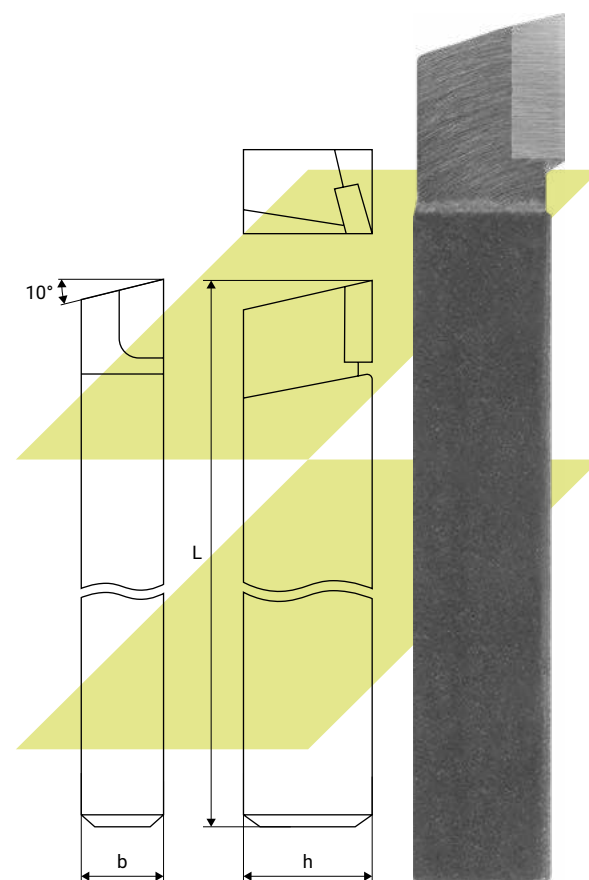

Резцы подрезные отогнутые с пластинами из твердого сплава

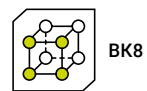

Артикул		Обозначение по ГОСТ		h, мм	b, мм	L, мм
		Угол врезки пластин 10°	Угол врезки пластин 0°			
1378732	●	2112-0101	2112-0103	12	12	100
1105988	●	2112-0084	2112-0086	16	10	110
1127614	●	2112-0011	2112-0051	16	12	100
1105991	●	2112-0003	2112-0053	20	12	125
1105994	●	2112-0013	2112-0055	20	16	120
1106000	●	2112-0005	2112-0057	25	16	140
1106006	●	2112-0015	2112-0061	25	20	140
1106012	●	2112-0007	2112-0063	32	20	170
1740136	●	2112-0017	2112-0065	32	25	170
1106018	●	2112-0009	2112-0067	40	25	200

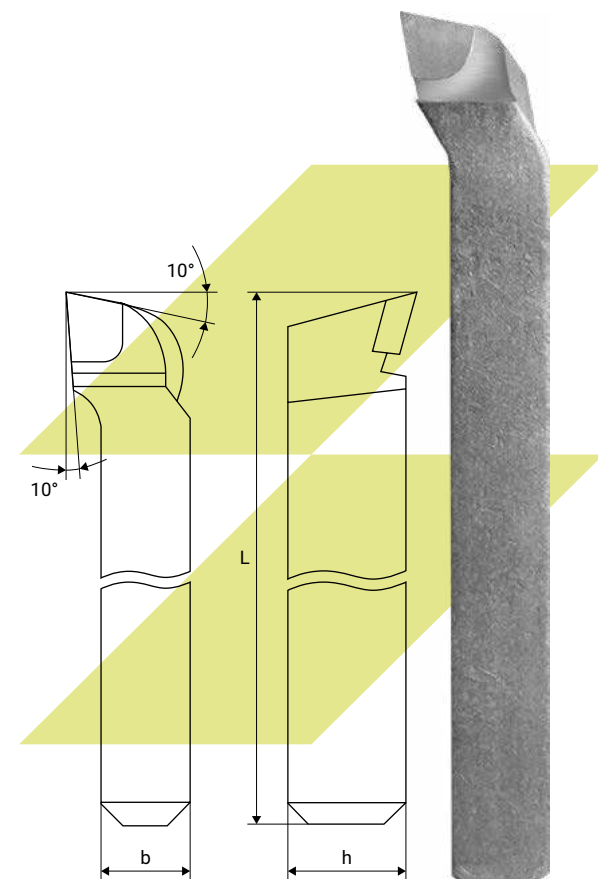

Резцы подрезные отогнутые с пластинами из твердого сплава

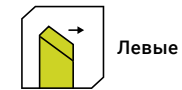
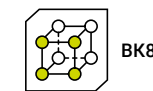

Артикул		Обозначение по ГОСТ		h, мм	b, мм	L, мм
		Угол врезки пластин 10°	Угол врезки пластин 0°			
1846981	●	2112-0102	2112-0104	12	12	70
1416893	●	2112-0085	2112-0087	16	10	110
1326567	●	2112-0012	2112-0052	16	12	100
1416894	●	2112-0004	2112-0054	20	12	120
1105995	●	2112-0006	2112-0058	20	16	140
1106001	●	2112-0006	2112-0058	25	16	140
1106007	●	2112-0016	2112-0062	25	20	140
1106013	●	2112-0008	2112-0064	32	20	170
1846990	●	2112-0018	2112-0066	32	25	170
1106019	●	2112-0010	2112-0068	40	25	200

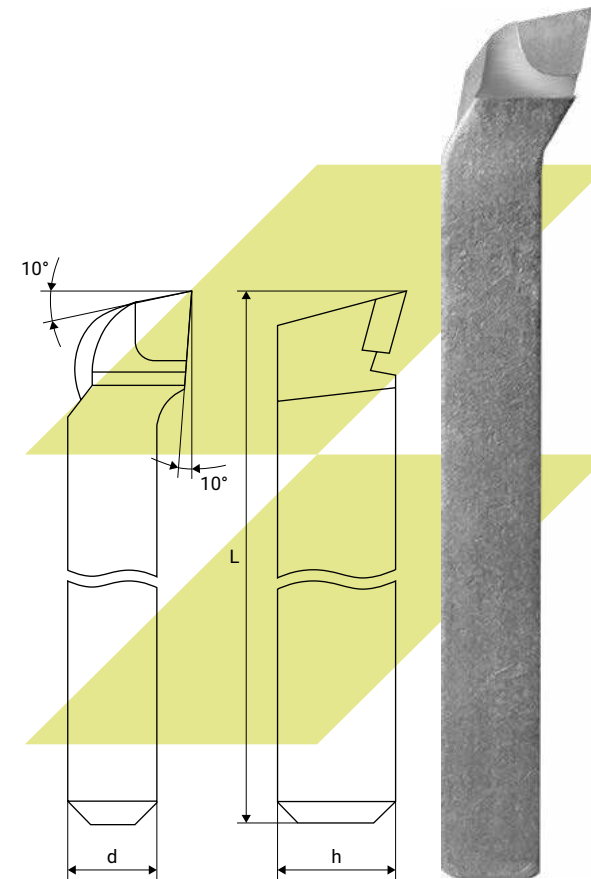

Резцы подрезные отогнутые с пластинами из твердого сплава



ГОСТ
18880-73



T15K6



Правые

Артикул		Обозначение по ГОСТ		h, мм	b, мм	L, мм
		Угол врезки пластин 10°	Угол врезки пластин 0°			
1480523	●	2112-0101	2112-0103	12	12	100
1105989	●	2112-0084	2112-0086	16	10	110
1143372	●	2112-0011	2112-0051	16	12	100
1105992	●	2112-0003	2112-0053	20	12	125
1105996	●	2112-0013	2112-0055	20	16	120
1106002	●	2112-0005	2112-0057	25	16	140
1106008	●	2112-0015	2112-0061	25	20	140
1106014	●	2112-0007	2112-0063	32	20	170
1416849	●	2112-0017	2112-0065	32	25	170
1106020	●	2112-0009	2112-0067	40	25	200

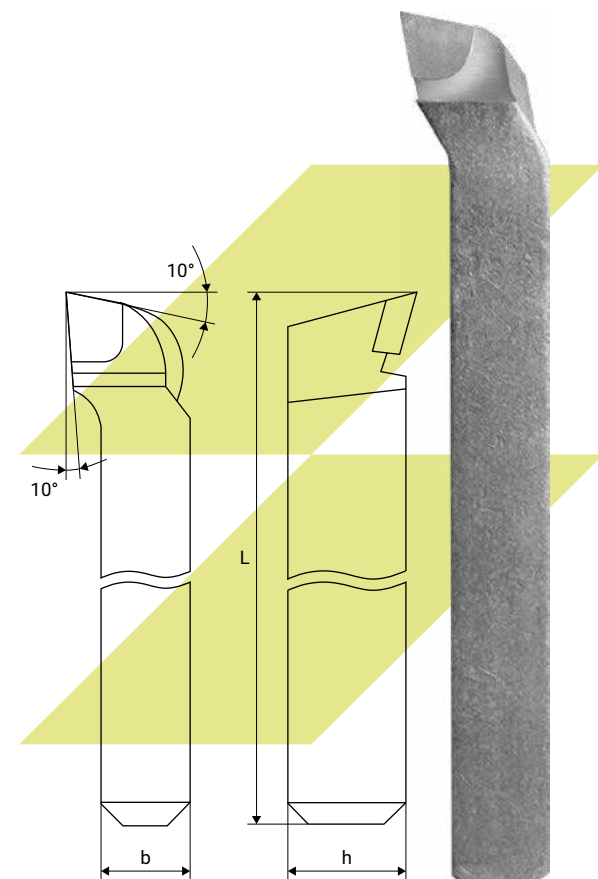

Резцы подрезные отогнутые с пластинами из твердого сплава



ГОСТ
18880-73



T15K6



Левые

Артикул		Обозначение по ГОСТ		h, мм	b, мм	L, мм
		Угол врезки пластин 10°	Угол врезки пластин 0°			
1846982	●	2112-0102	2112-0104	12	12	70
1480524	●	2112-0085	2112-0087	16	10	110
1846986	●	2112-0012	2112-0052	16	12	100
1846988	●	2112-0004	2112-0054	20	12	125
1105997	●	2112-0014	2112-0056	20	16	120
1106003	●	2112-0006	2112-0058	25	16	140
1106009	●	2112-0016	2112-0062	25	20	140
1106015	●	2112-0008	2112-0064	32	20	170
1846991	●	212-0018	2112-0066	32	25	170
1106021	●	2112-0010	2112-0068	40	25	200

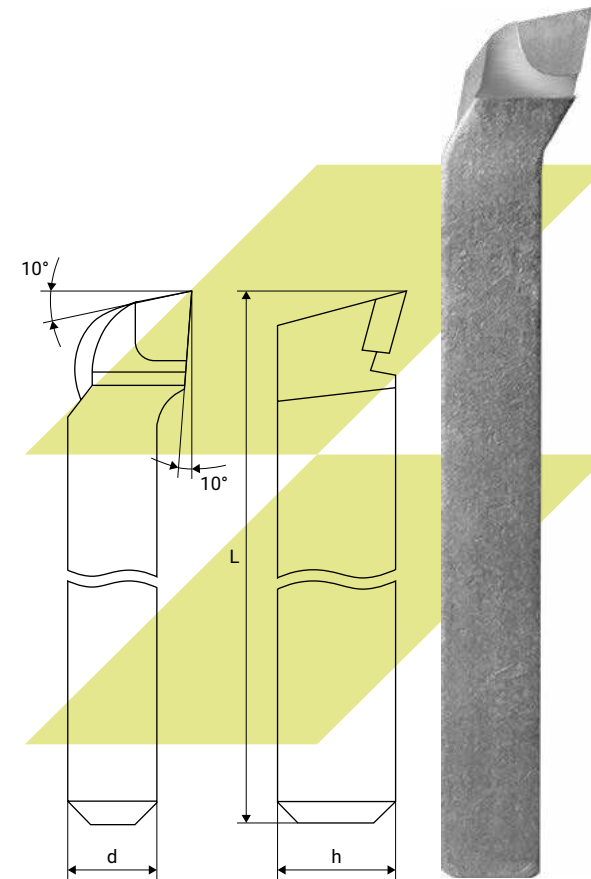

Резцы подрезные отогнутые с пластинами из твердого сплава



ГОСТ
18880-73

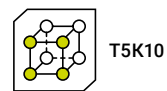

T5K10



Правые

Артикул		Обозначение по ГОСТ		h, мм	b, мм	L, мм
		Угол врезки пластин 10°	Угол врезки пластин 0°			
1846983	●	2112-0101	2112-0103	12	12	70
1105990	●	2112-0084	2112-0086	16	10	110
1342923	●	2112-0011	2112-0051	16	12	100
1105993	●	2112-0003	2112-0053	20	12	125
1105998	●	2112-0013	2112-0055	20	16	120
1106004	●	2112-0005	2112-0057	25	16	140
1106010	●	2112-0015	2112-0061	25	20	140
1106016	●	2112-0007	2112-0063	32	20	170
1584669	●	2112-0017	2112-0065	32	25	170
1106022	●	2112-0009	2112-0067	40	25	200

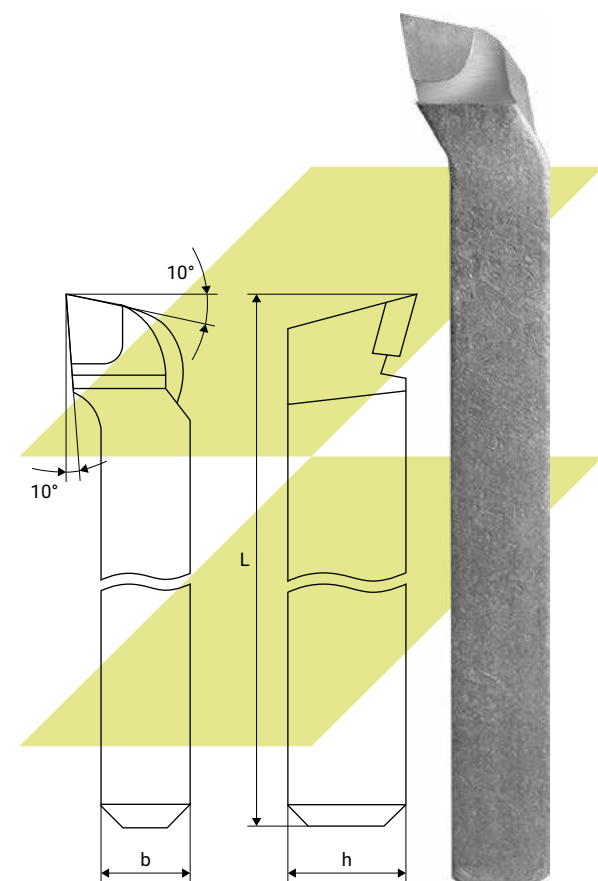

Резцы подрезные отогнутые с пластинами из твердого сплава



ГОСТ
18880-73



T5K10



Левые

Артикул		Обозначение по ГОСТ		h, мм	b, мм	L, мм
		Угол врезки пластин 10°	Угол врезки пластин 0°			
1846984	●	2112-0102	2112-0104	12	12	70
1846985	●	2112-0055	2112-0086	16	10	110
1846987	●	2112-0012	2112-0052	16	12	100
1846989	●	2112-0004	2112-0054	20	12	125
1105999	●	2112-0014	2112-0056	20	16	120
1106005	●	2112-0006	2112-0058	25	16	140
1106011	●	2112-0016	2112-0062	25	20	140
1106017	●	2112-0008	2112-0064	32	20	170
1846992	●	2112-0017	2112-0065	32	25	170
1106023	●	2112-0010	2112-0068	40	25	200

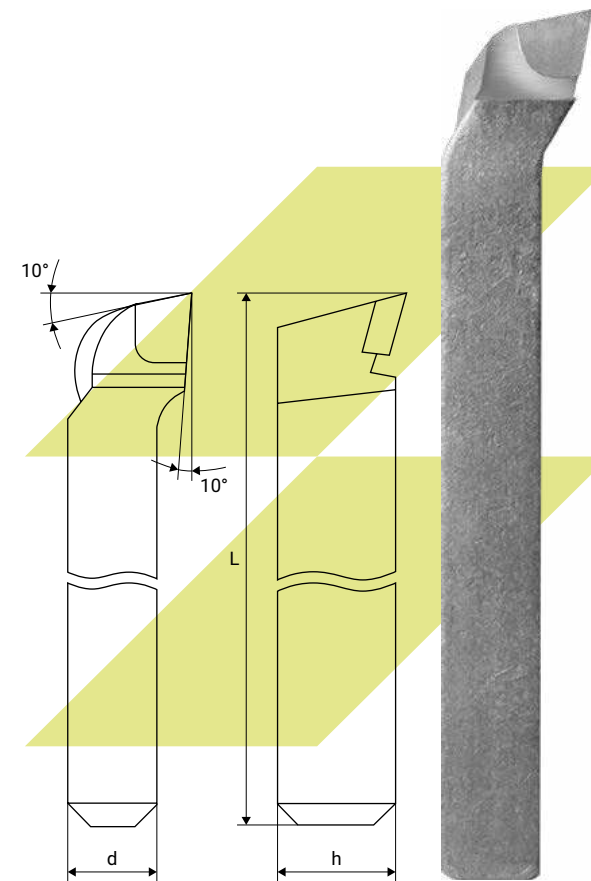

Резцы расточные с пластинами из твердого сплава для обработки глухих отверстий

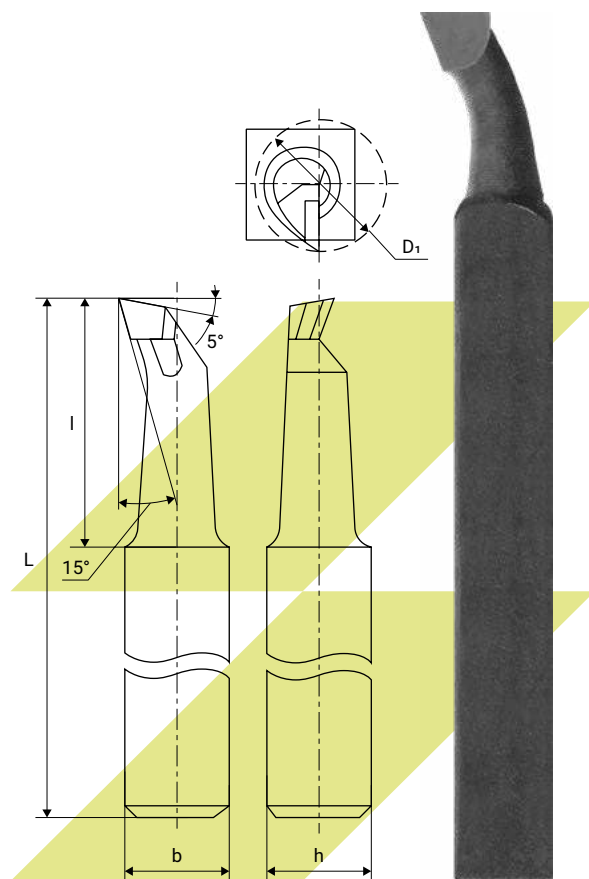
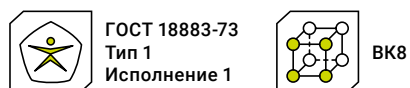

Артикул	🚚	Обозначение по ГОСТ		L, мм	l, мм	h, мм	b, мм
		Угол врезки пластин 10°	Угол врезки пластин 0°				
1417141	●	2141-0201	2141-0202	100	20	12	12
1106192	●	-	-	130	40	12	12
1106195	●	2141-0002	2141-0022	120	25	16	16
1106198	●	2141-0004	2141-0024	140	40	16	16
1106201	●	2141-0005	2141-0025	170	60	16	16
1106204	●	2141-0006	2141-0026	140	40	20	20
1106207	●	2141-0008	2141-0028	170	50	20	20
1106210	●	2141-0007	2141-0027	170	70	20	20
1106213	●	2141-0009	2141-0029	200	80	20	20
1106216	●	2141-0010	2141-0030	200	70	25	25
1106219	●	2141-0011	2141-0031	240	100	25	25

Резцы расточные с пластинами из твердого сплава для обработки глухих отверстий

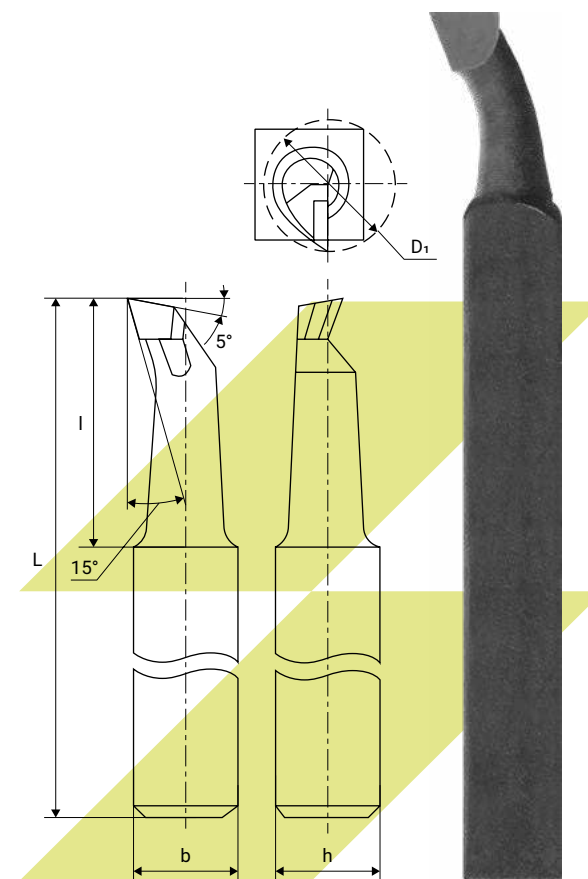

Артикул	🚚	Обозначение по ГОСТ		D ₁ , мм	L, мм	l, мм	h, мм	b, мм
		Угол врезки пластин 10°	Угол врезки пластин 0°					
1415835	●	2141-0201	2141-0202		100	20	12	12
1106193	●	-	-		130	40	12	12
1106196	●	2141-0002	2141-0022		120	25	16	16
1106199	●	2141-0004	2141-0024		140	40	16	16
1106202	●	2141-0005	2141-0025		170	60	16	16
1106205	●	2141-0006	2141-0026		140	40	20	20
1106208	●	2141-0008	2141-0028		170	50	20	20
1106211	●	2141-0007	2141-0027		170	70	20	20
1106214	●	2141-0009	2141-0029		200	80	20	20
1106217	●	2141-0010	2141-0030		200	70	25	25
1106220	●	2141-0011	2141-0031		240	100	25	25

Резцы расточные с пластинами из твердого сплава для обработки глухих отверстий

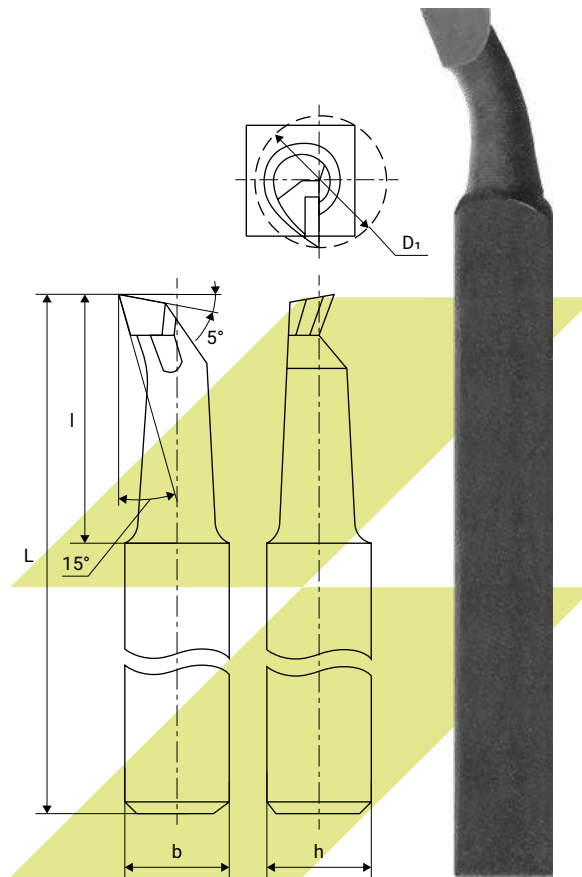
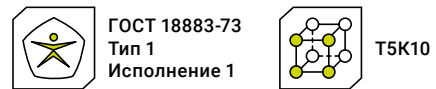

Артикул		Обозначение по ГОСТ		D ₁ , мм	L, мм	I, мм	h, мм	b, мм
		Угол врезки пластин 10°	Угол врезки пластин 0°					
1597480	●	2141-0201	2141-0202		100	20	12	12
1106194	●	–	–		140	40	12	12
1106197	●	2141-0002	2141-0022		120	25	16	16
1106200	●	2141-0004	2141-0024		140	40	16	16
1106203	●	2141-0005	2141-0025		170	60	16	16
1106206	●	2141-0006	2141-0026		140	40	20	20
1106209	●	2141-0008	2141-0028		170	50	20	20
1106212	●	2141-0007	2141-0027		170	70	20	20
1106215	●	2141-0009	2141-0029		200	80	20	20
1106218	●	2141-0010	2141-0030		200	70	25	25
1106221	●	2141-0011	2141-0031		240	100	25	25

Резцы расточные с пластинами из твердого сплава для обработки глухих отверстий

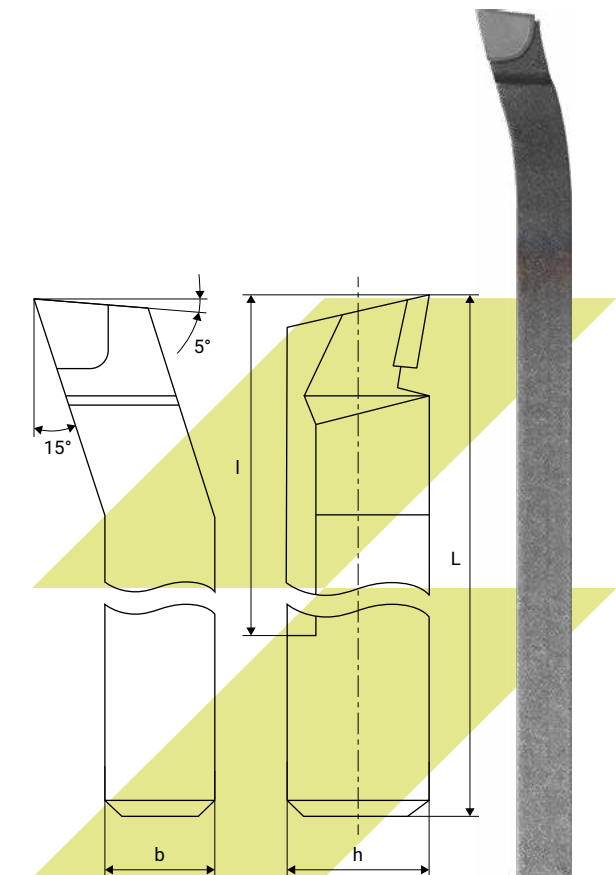
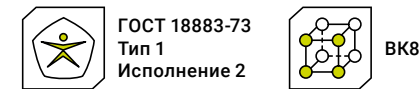

Артикул		Обозначение по ГОСТ		L, мм	I, мм	h, мм	b, мм
		Угол врезки пластин 10°	Угол врезки пластин 0°				
1239997	●	2141-0056	2141-0041	170	80	16	12
1106225	●	2141-0057	2141-0042	200	100	20	16
1106231	●	–	–	200	100	25	16
1106228	●	2141-0011	2141-0031	240	100	25	20
1106237	●	2141-0059	2141-0044	280	160	32	25
1106240	●	–	–	300	180	40	25
1326019	●	2141-0060	2141-0045	300	180	40	32

Резцы расточные с пластинами из твердого сплава для обработки глухих отверстий

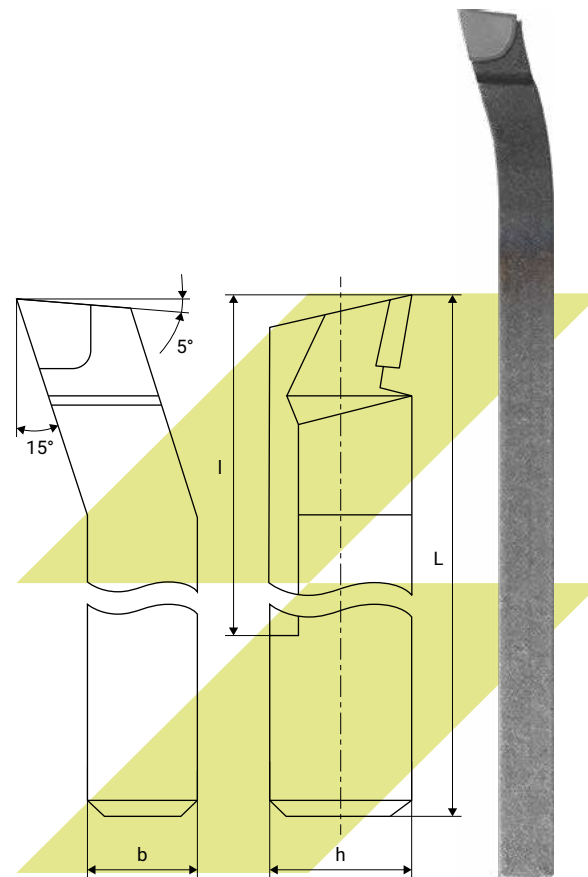
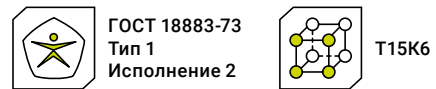

Артикул		Обозначение по ГОСТ		L, мм	l, мм	h, мм	b, мм
		Угол врезки пластин 10°	Угол врезки пластин 0°				
1124655	●	2141-0056	2141-0041	170	80	16	12
1106226	●	2141-0057	2141-0042	200	100	20	16
1106232	●	—	—	200	100	25	16
1106229	●	2141-0011	2141-0031	240	100	25	20
1106238	●	2141-0059	2141-0044	280	160	32	25
1106241	●	—	—	300	180	40	25
1417652	●	2141-0060	2141-0045	300	180	40	32

Резцы расточные с пластинами из твердого сплава для обработки глухих отверстий

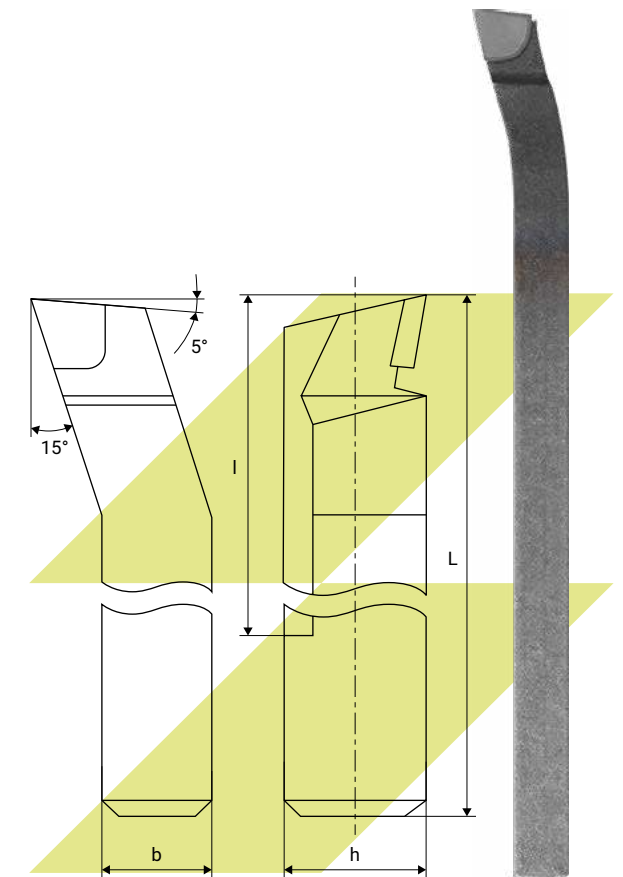
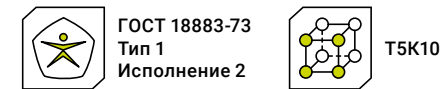

Артикул		Обозначение по ГОСТ		L, мм	l, мм	h, мм	b, мм
		Угол врезки пластин 10°	Угол врезки пластин 0°				
1150295	●	2141-0056	2141-0041	170	80	16	12
1106227	●	2141-0057	2141-0042	200	100	20	16
1106233	●	—	—	200	100	25	16
1106230	●	2141-0011	2141-0031	240	100	25	20
1106239	●	2141-0059	2141-0044	280	160	32	25
1106242	●	—	—	300	180	40	25
1378518	●	2141-0060	2141-0045	300	180	40	32

Резцы резьбовые с пластинами из твердого сплава для наружной метрической резьбы

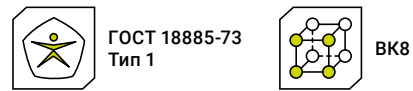

Артикул	Обозначение по ГОСТ	L, мм	P, мм	h, мм	b, мм
1106324	2660-0001	100	0,5–2,5	16	10
1106327	2660-0003	120	0,8–3,0	20	12
1106330	–	140	–	20	16
1106333	2660-0005	140	1,25–5	25	16
1106339	2660-0007	170	2–6	32	20
1106342	–	200	–	40	25

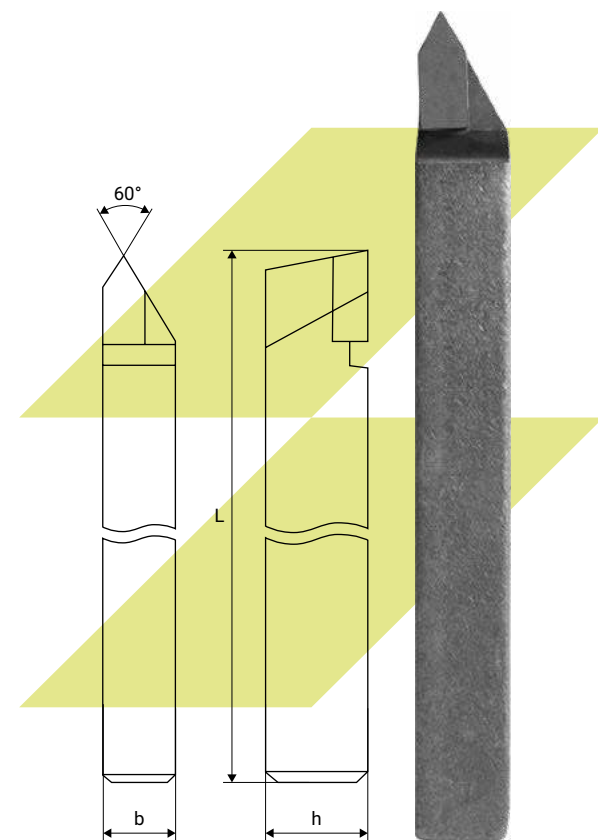

Резцы резьбовые с пластинами из твердого сплава для наружной метрической резьбы

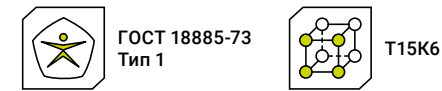

Артикул	Обозначение по ГОСТ	L, мм	P, мм	h, мм	b, мм
1106325	2600-0001	100	0,5–2,5	16	10
1106328	2660-0003	120	0,8–3,0	20	12
1106331	–	140	–	20	16
1106334	2660-0005	140	1,25–5	25	16
1106340	2660-0007	170	2–6	32	20
1106343	–	200	–	40	25

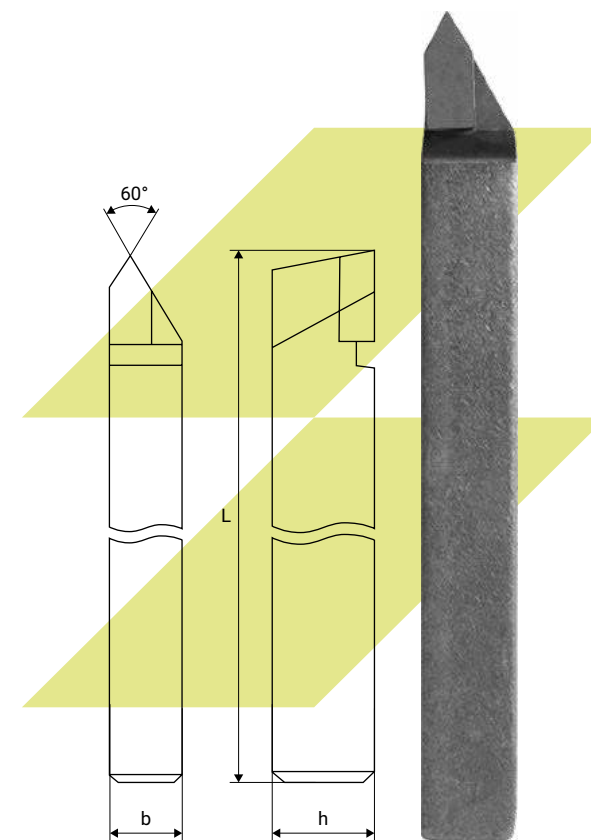

Резцы резьбовые с пластинами из твердого сплава для наружной метрической резьбы

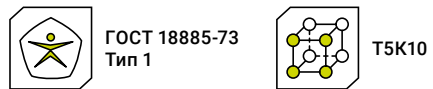

Артикул	Обозначение по ГОСТ	L, мм	P, мм	h, мм	b, мм
1106326	2660-0001	100	0,5–2,5	16	10
1106329	2660-0003	120	0,8–3,0	20	12
1106332	–	140	–	20	16
1106335	2660-0005	140	1,25–5	25	16
1106341	2660-0007	170	2–6	32	20
1106344	–	200	–	40	25

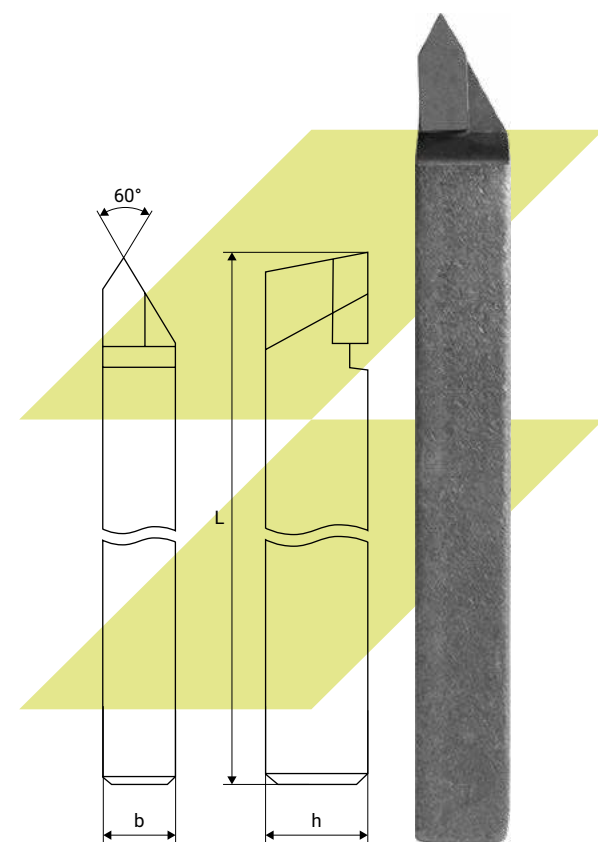

Резцы резьбовые с пластинами из твердого сплава для внутренней метрической резьбы

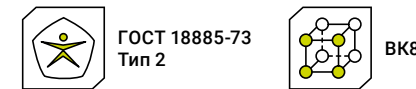

Артикул	Обозначение по ГОСТ	L, мм	P, мм	h, мм	b, мм
1597481	2662-0001	120	0,75–2,50	10	10
1106294	–	140	–	10	10
1106300	2662-0003	140	1–3	12	12
1106306	2662-0005	170	1,5–4	16	16
1106312	2662-0007	200	2–5	20	20
1106318	2662-0009	240	3–6	25	25

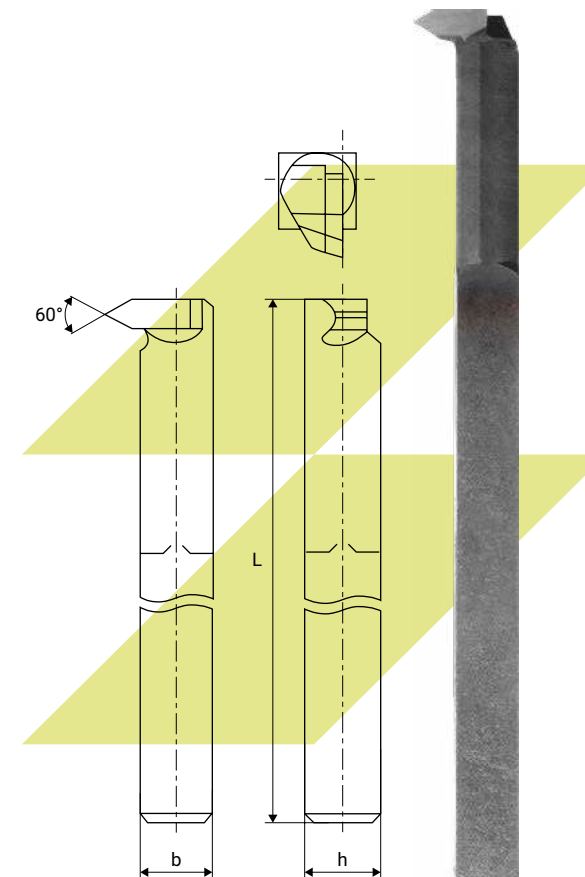

Резцы резьбовые с пластинами из твердого сплава для внутренней метрической резьбы

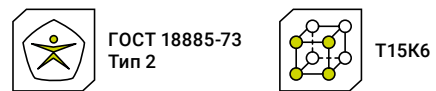

Артикул	Обозначение по ГОСТ	L, мм	P, мм	h, мм	b, мм
1764184	2662-0001	120	0,75–2,5	10	10
1106296	–	140	–	10	10
1106302	2662-0003	140	1–3	12	12
1106308	2662-0005	170	1,5–4	16	16
1106314	2662-0007	200	2–5	20	20
1106320	2662-0009	240	3–6	25	25

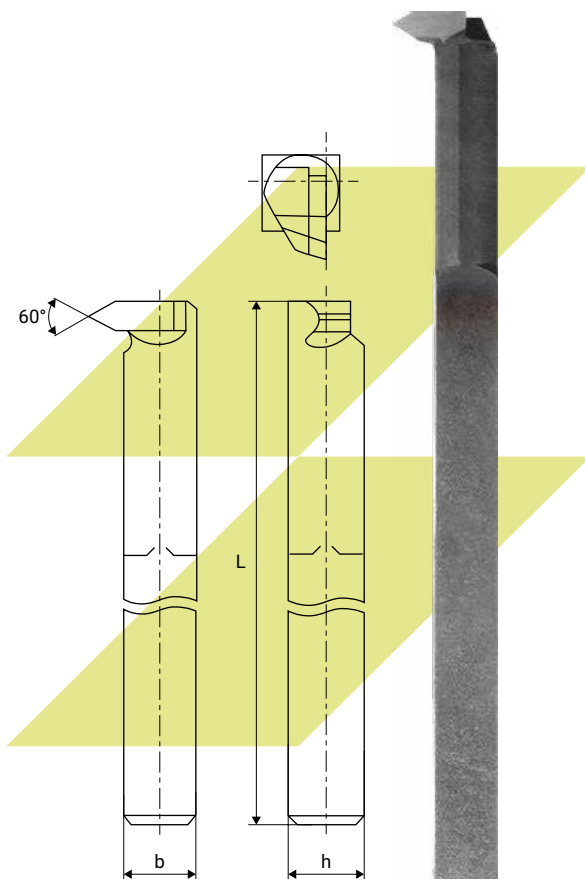

Резцы резьбовые с пластинами из твердого сплава для внутренней метрической резьбы

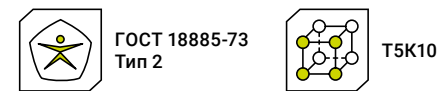

Артикул	Обозначение по ГОСТ	L, мм	P, мм	h, мм	b, мм
1597482	2662-0001	120	0,75–2,50	10	10
1106298	–	140	–	10	10
1106304	2662-0003	140	1–3	12	12
1106310	2662-0005	170	1,5–4	16	16
1106316	2662-0007	200	2–5	20	20
1106322	2662-0009	240	3–6	25	25

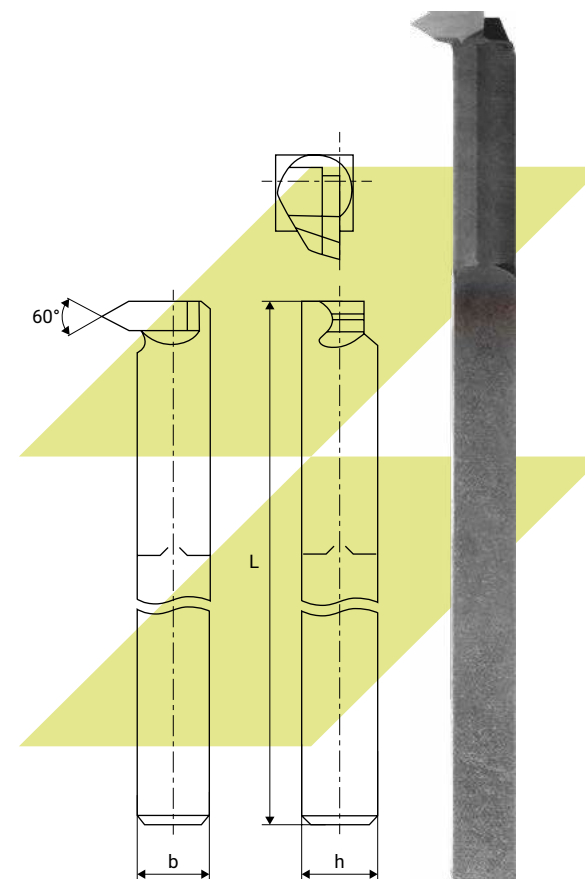

Резцы для внутренних канавок

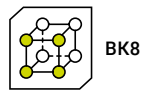

Артикул		h, мм	b, мм	L, мм	a, мм
1478515	●	16	16	170	3
1105913	●	16	16	170	3.5
1105916	●	16	16	170	4
1105919	●	16	16	170	4.5
1612106	●	20	20	200	3
1584692	●	20	20	200	3.5
1105922	●	20	20	200	4
1105925	●	20	20	200	4.5
1105928	●	20	20	200	5
1105931	●	20	20	200	5.5
1584694	●	20	20	200	6
1289601	●	25	25	240	6

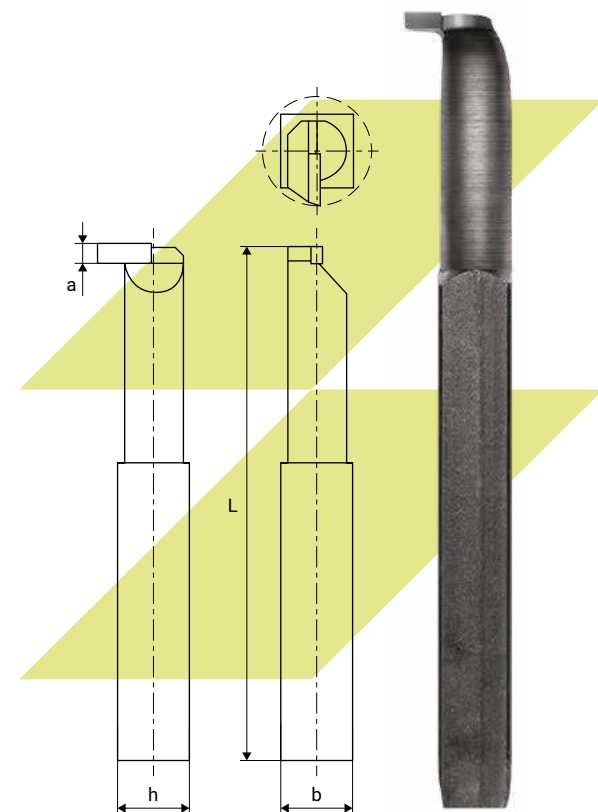

Резцы для внутренних канавок

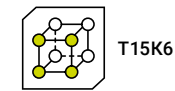

Артикул		h, мм	b, мм	L, мм	a, мм
1584690	●	16	16	170	3
1105914	●	16	16	170	3.5
1105917	●	16	16	170	4
1105920	●	16	16	170	4.5
1418803	●	20	20	200	3.5
1105923	●	20	20	200	4
1105926	●	20	20	200	4.5
1105929	●	20	20	200	5
1105932	●	20	20	200	5.5
1287107	●	20	20	200	6
1289602	●	25	25	240	6

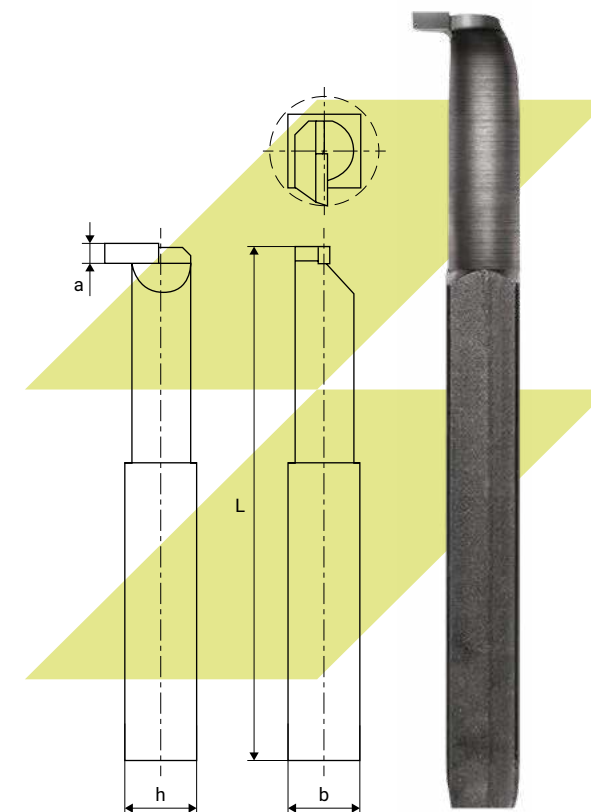

Резцы для внутренних канавок



T5K10

Артикул		h, мм	b, мм	L, мм	a, мм
1479620	●	16	16	150	7
1584691	●	16	16	170	3
1105915	●	16	16	170	3.5
1105918	●	16	16	170	4
1105921	●	16	16	170	4.5
1584693	●	20	20	200	3.5
1105924	●	20	20	200	4
1105927	●	20	20	200	4.5
1105930	●	20	20	200	5
1105933	●	20	20	200	5.5
1584695	●	20	20	200	6
1377591	●	20	20	210	8
1289603	●	25	25	240	6

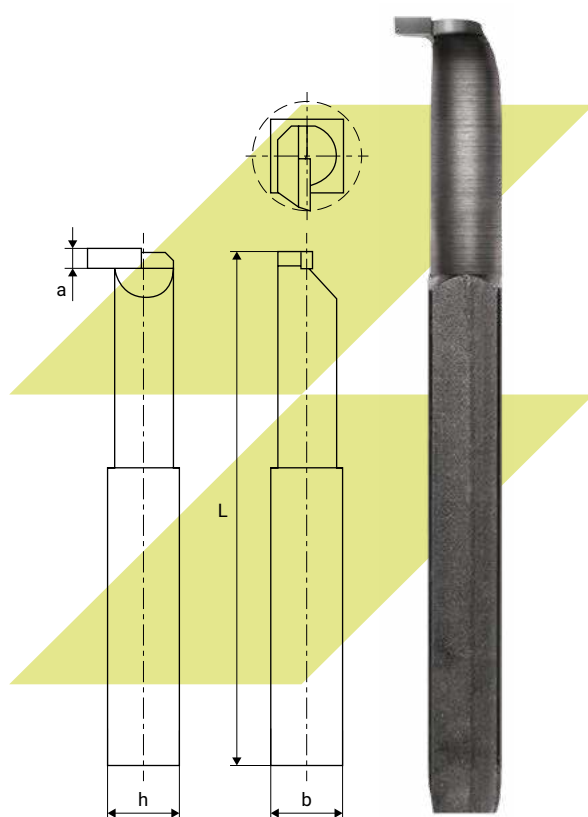

Резцы чистовые широкие с пластинами из твердого сплава



ГОСТ 18881-73



VK8

Артикул		Обозначение по ГОСТ	L, мм	P, мм	h, мм	b, мм	L, мм
1106345	●	2120-0051	100	16	16	10	10
1847077	●	2120-0064	110	16	16	16	16
1106351	●	2120-0052	125	20	20	12	12
1847079	●	2120-0065	125	20	20	20	20
1106357	●	2120-0053	140	25	25	16	16
1847082	●	2120-0066	140	25	25	25	25
1106363	●	2120-0054	170	32	32	20	20
1847085	●	2120-0067	170	32	32	32	32
1106369	●	2120-0055	200	40	40	25	25
1220549	●	2120-0069	240	50	50	32	32

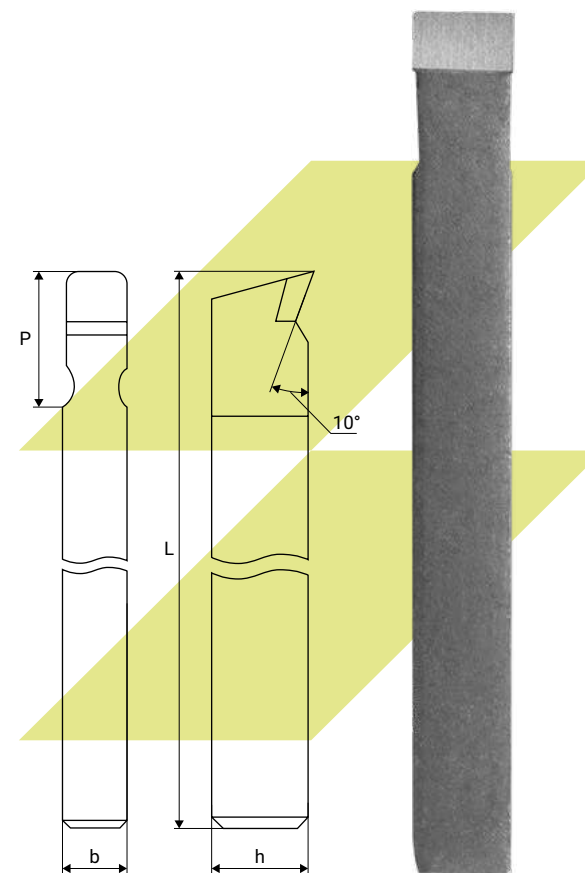

Резцы чистовые широкие с пластинами из твердого сплава

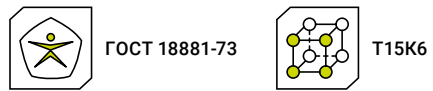

Артикул	Обозначение по ГОСТ	L, мм	P, мм	h, мм	b, мм	L, мм
1106346	2120-0051	100	16	16	10	10
1150293	2120-0064	110	16	16	16	16
1106352	2120-0052	125	20	20	12	12
1847080	2120-0065	125	20	20	20	20
1106358	2120-0053	140	25	25	16	16
1847083	2120-0066	140	25	25	25	25
1106364	2120-0054	170	32	32	20	20
1847086	2120-0067	170	32	32	32	32
1106370	2120-0055	200	40	40	25	25
1847087	2120-0069	240	50	50	32	32

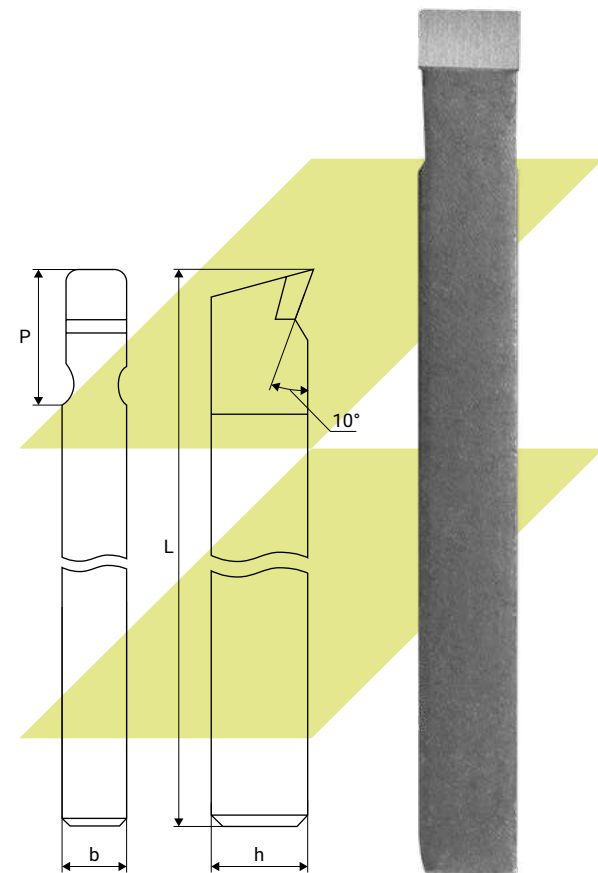

Резцы чистовые широкие с пластинами из твердого сплава

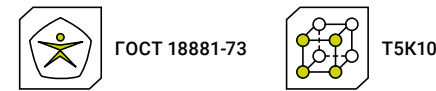

Артикул	Обозначение по ГОСТ	L, мм	P, мм	h, мм	b, мм	L, мм
1106347	2120-0051	100	16	16	10	10
1847078	2120-0064	110	16	16	16	16
1106353	2120-0052	125	20	20	12	12
1847081	2120-0065	125	20	20	20	20
1106359	2120-0053	140	25	25	16	16
1847084	2120-0066	140	25	25	25	25
1106365	2120-0054	170	32	32	20	20
1582119	2120-0067	170	32	32	32	32
1106371	2120-0055	200	40	40	25	25
1847088	2120-0069	240	50	50	32	32

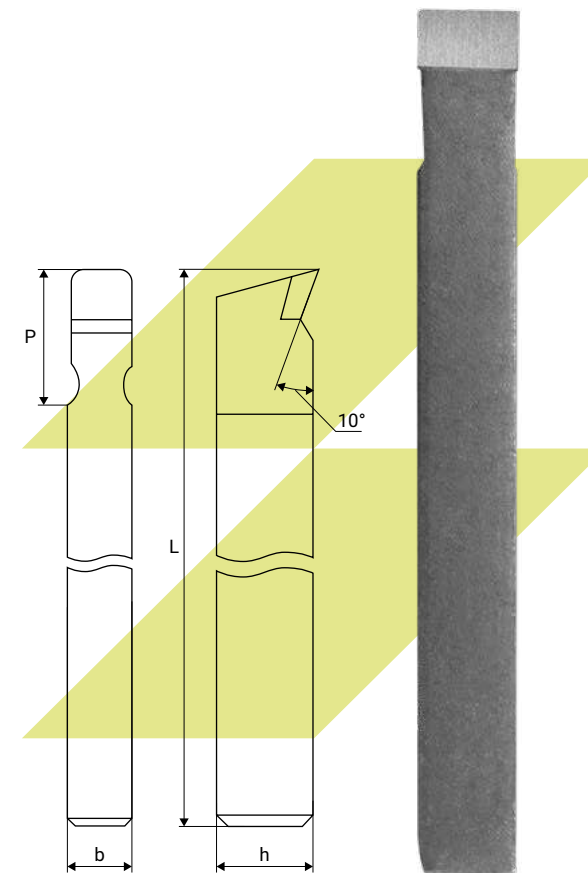

Резцы расточные цельные твердосплавные со стальным хвостовиком для глухих отверстий

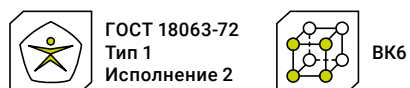

Артикул	Обозначение по ГОСТ	D ₁ , мм	D, мм	L, мм	L, мм
116356	2145-0041	3	6	40	10
1847053	2145-0042	3	6	50	20
106500	2145-0043	4	6	40	10
116358	2145-0044	4	6	50	20
1127359	2145-0045	5	10	45	15
106503	2145-0046	5	10	60	30
1127360	2145-0047	6	10	45	15
1847059	2145-0048	6	10	65	35
1127361	2145-0049	7	12	45	12
1127362	2145-0050	7	12	65	35
1127363	2145-0051	8	12	50	20
1127364	2145-0052	8	12	70	40

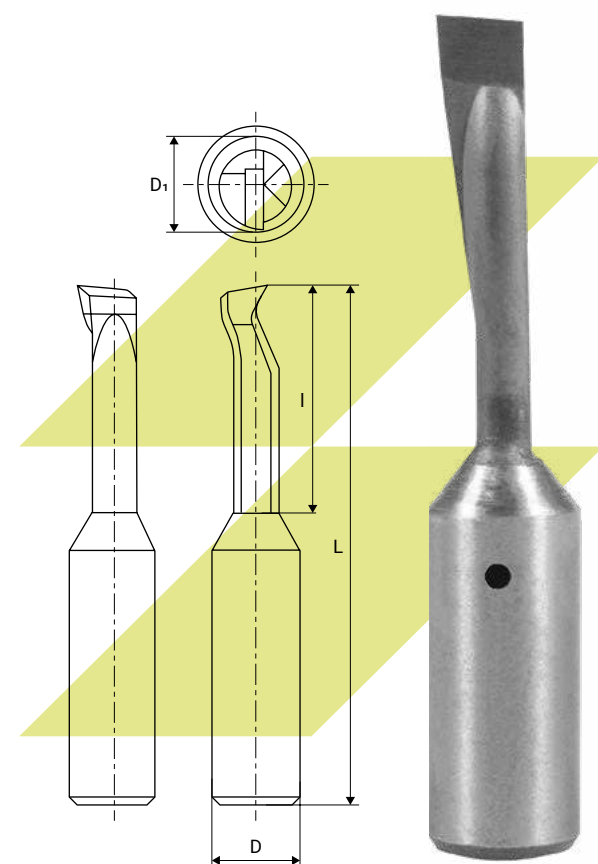

Резцы расточные цельные твердосплавные со стальным хвостовиком для глухих отверстий

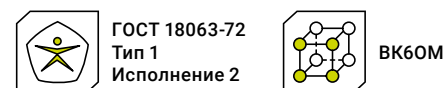

Артикул	Обозначение по ГОСТ	D ₁ , мм	D, мм	L, мм	L, мм
1847052	2145-0041	3	6	40	10
106499	2145-0042	3	6	50	20
1847054	2145-0043	4	6	40	10
1847055	2145-0044	4	6	50	20
1847056	2145-0045	5	10	45	15
1847057	2145-0046	5	10	60	30
1847058	2145-0047	6	10	45	15
1582420	2145-0048	6	10	65	35
1847060	2145-0049	7	12	45	15
1847061	2145-0050	7	12	65	35
1847062	2145-0051	8	12	50	20
1582421	2145-0052	8	12	70	40

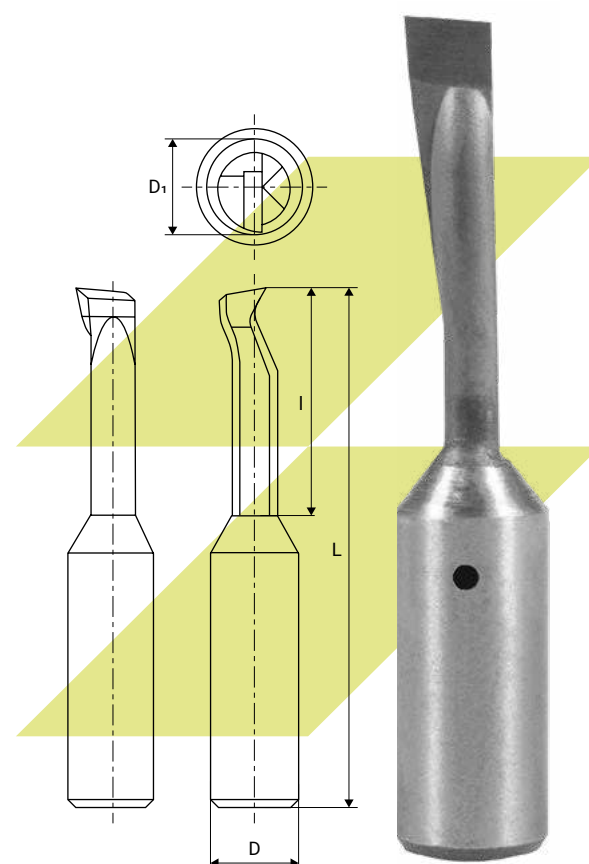

Резцы отрезные из быстрорежущей стали

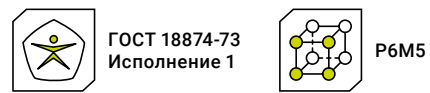

Артикул		h, мм	b, мм	L, мм
1254895	●	16	10	100
106236	●	20	12	120
106240	●	20	16	140
106246	●	25	16	140
119061	●	32	20	170

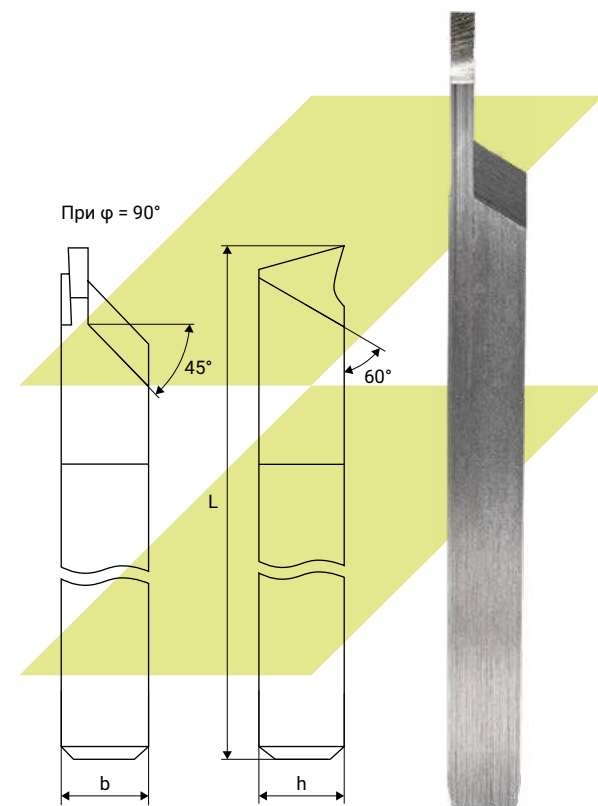

Резцы отрезные из быстрорежущей стали

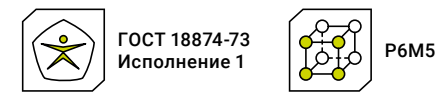

Артикул		h, мм	b, мм	L, мм
1846972	●	16	10	100
1846977	●	20	12	120
1584115	●	25	16	140
1846978	●	32	20	170

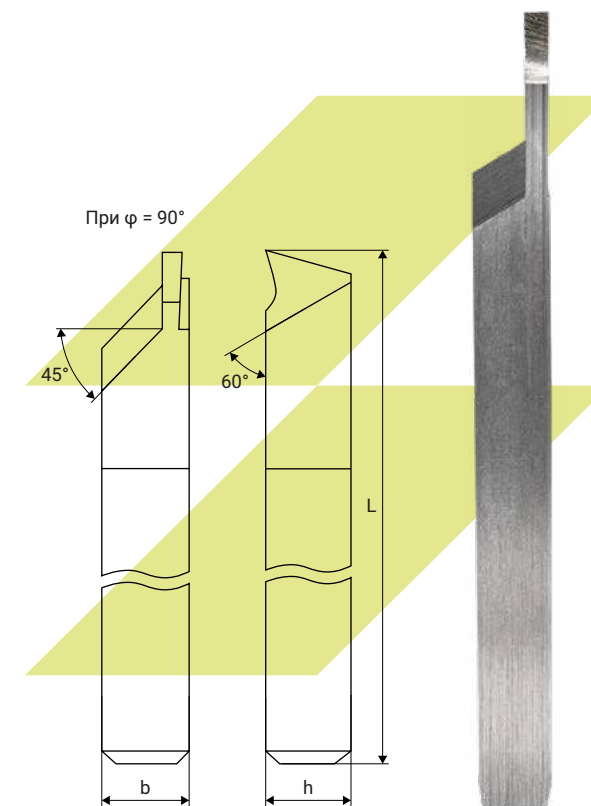

Резцы проходные отогнутые из быстрорежущей стали

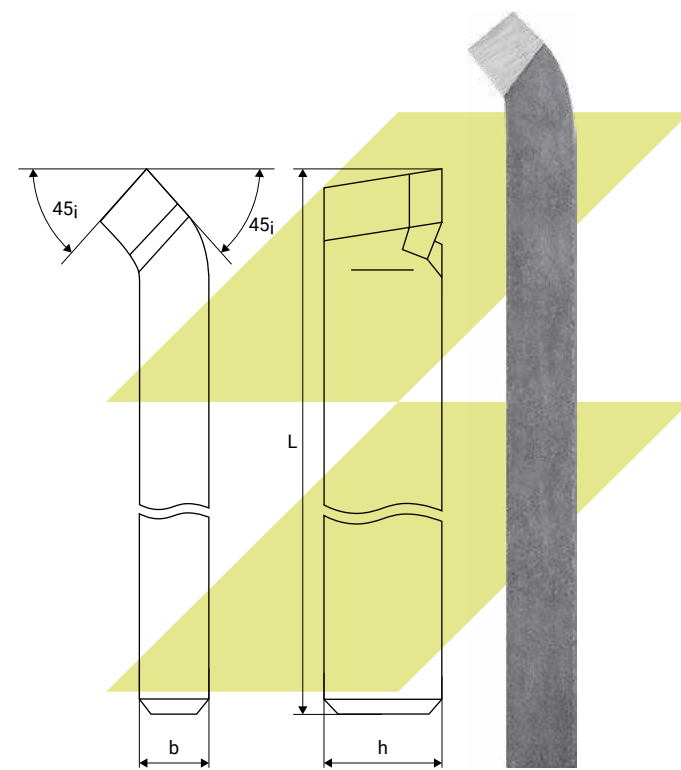
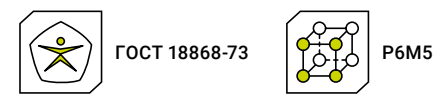

Артикул		Обозначение по ГОСТ		L, мм	h, мм	b, мм
		Угол врезки пластин 12°	Угол врезки пластин 0°			
106313	○	2102-0501	2102-0101	110	16	10
106323	○	2102-0503	2102-0103	125	20	12
106343	○	2102-0505	2102-0105	140	25	16
106362	○	2102-0507	2102-0107	170	32	20
106378	○	2102-0509	2102-0109	200	40	25

Резцы проходные отогнутые из быстрорежущей стали

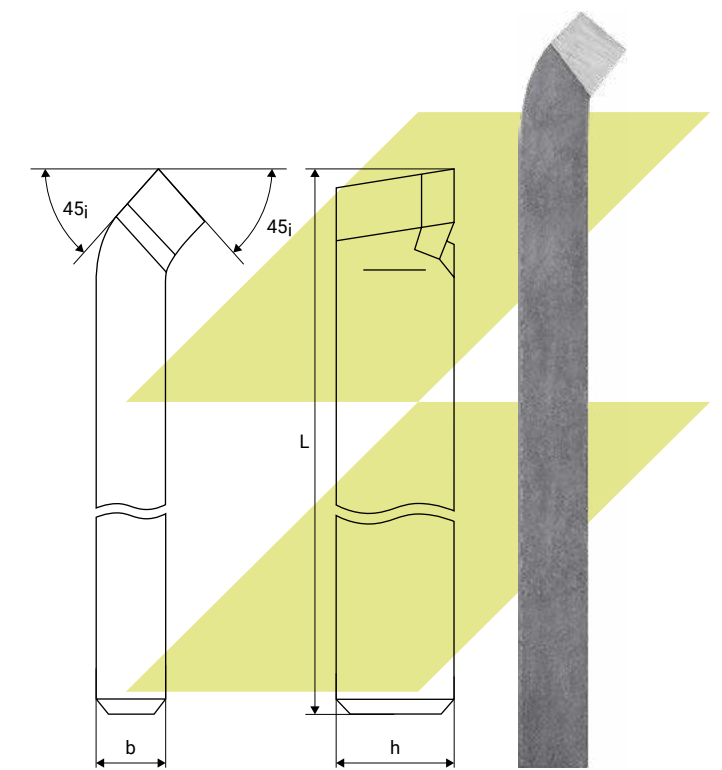
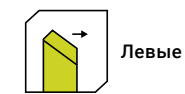
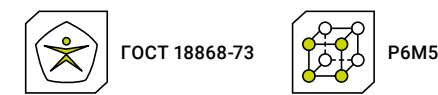

Артикул		Обозначение по ГОСТ		L, мм	h, мм	b, мм
		Угол врезки пластин 12°	Угол врезки пластин 0°			
1846994	○	2102-0502	2102-0102	110	16	10
1582771	○	2102-0504	2102-0104	120	20	12
106344	○	2102-0506	2102-0106	140	25	16
1847006	○	2102-0508	2102-0108	170	32	20
1106376	○	2102-0510	2102-0110	200	40	25

Резцы проходные упорные из быстрорежущей стали

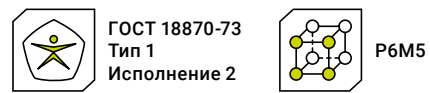

Артикул		h, мм	b, мм	L, мм
1378517	●	12	12	70
1752014	●	16	16	80
1847045	●	20	12	100
1415855	●	20	20	100
1106389	●	25	16	120
1847050	●	32	20	140

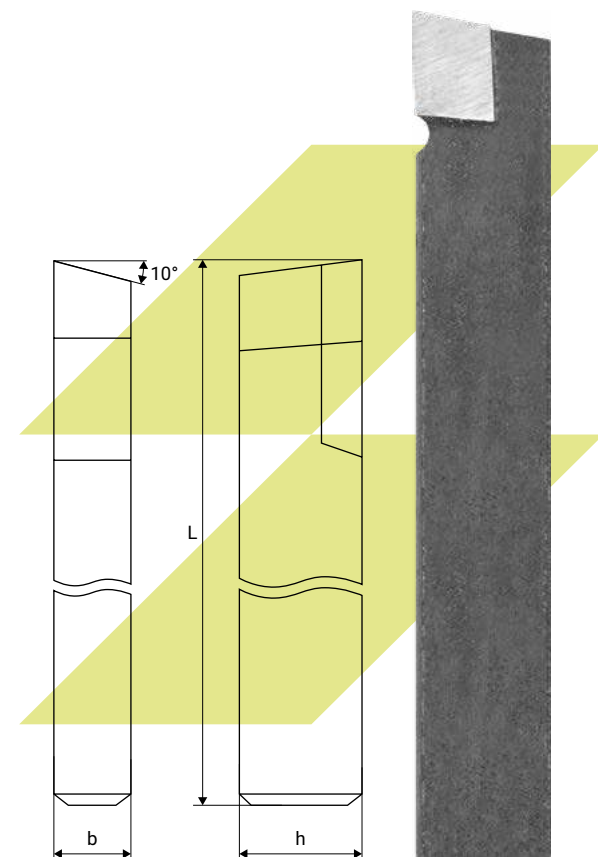

Резцы проходные упорные из быстрорежущей стали

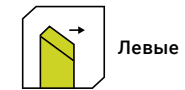
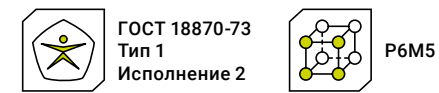

Артикул		h, мм	b, мм	L, мм
1847032	●	12	12	70
1847042	●	16	16	80
1847046	●	20	12	100
1624310	●	25	16	120
1847051	●	32	20	140

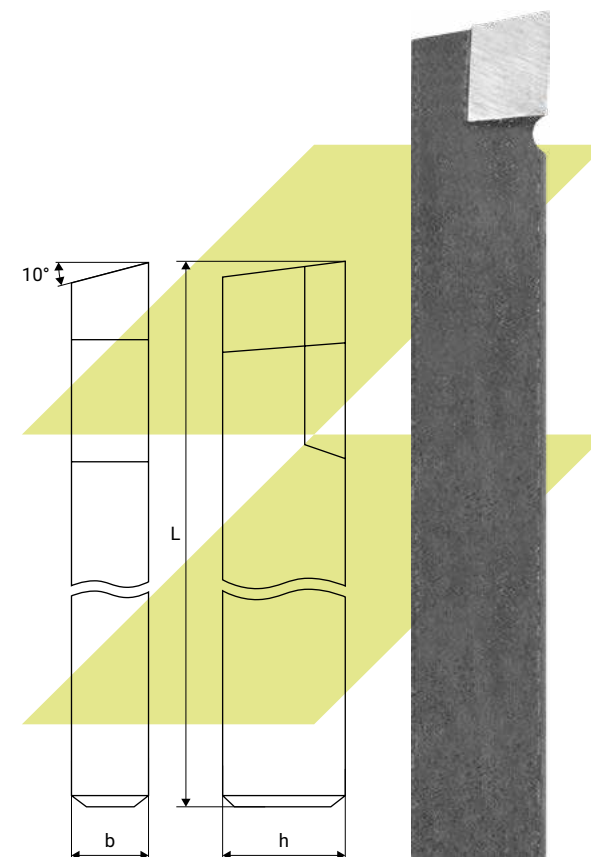

Резцы проходные упорные изогнутые из быстрорежущей стали

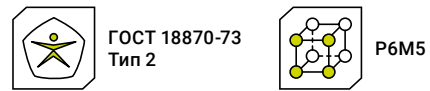

Артикул		h, мм	b, мм	L, мм
1847012	●	16	10	100
106456	●	20	12	120
106471	●	25	16	140
1106386	●	32	20	170
1106390	●	40	25	200

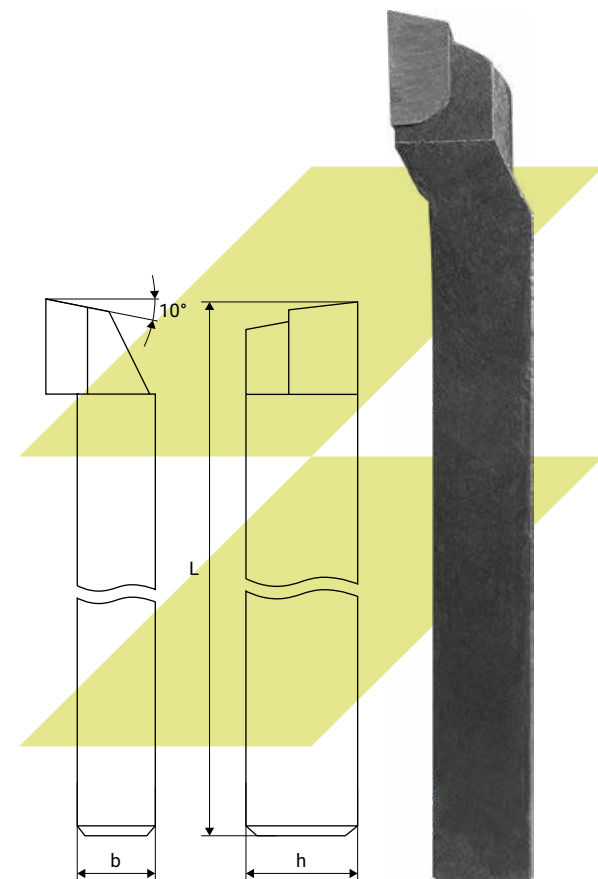

Резцы проходные упорные изогнутые из быстрорежущей стали

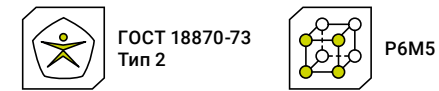

Артикул		h, мм	b, мм	L, мм
1847013	●	16	10	100
1106380	●	20	12	120
1106381	●	25	16	140
1106382	●	32	20	170
1106391	●	40	25	200

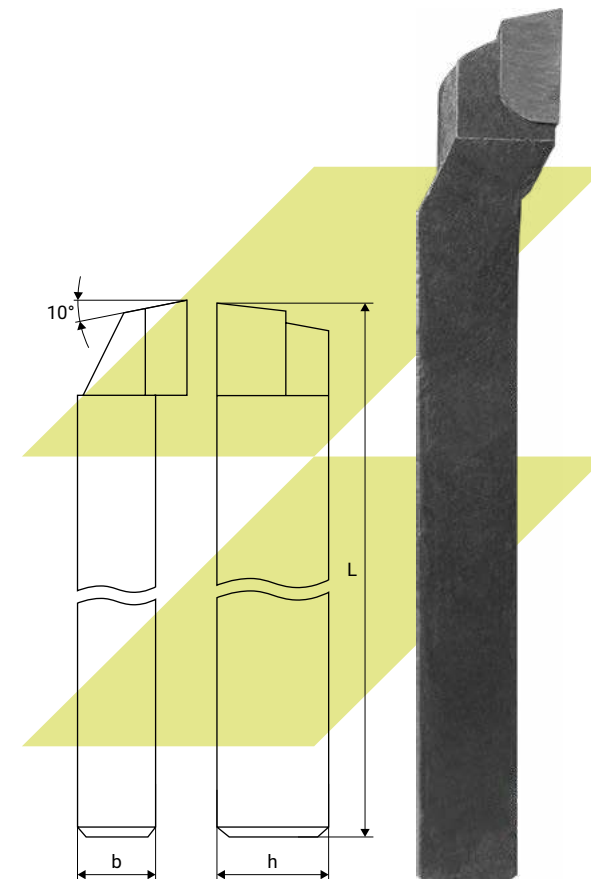

Резцы подрезные торцовые с пластинами из быстрорежущей стали



Артикул	Обозначение по ГОСТ	h, мм	b, мм	L, мм
106271	2112-0031	16	10	110
1252531	2112-0033	20	12	125
106287	2112-0035	25	16	140
1105237	2112-0037	32	20	170
1106375	2112-0039	40	25	200

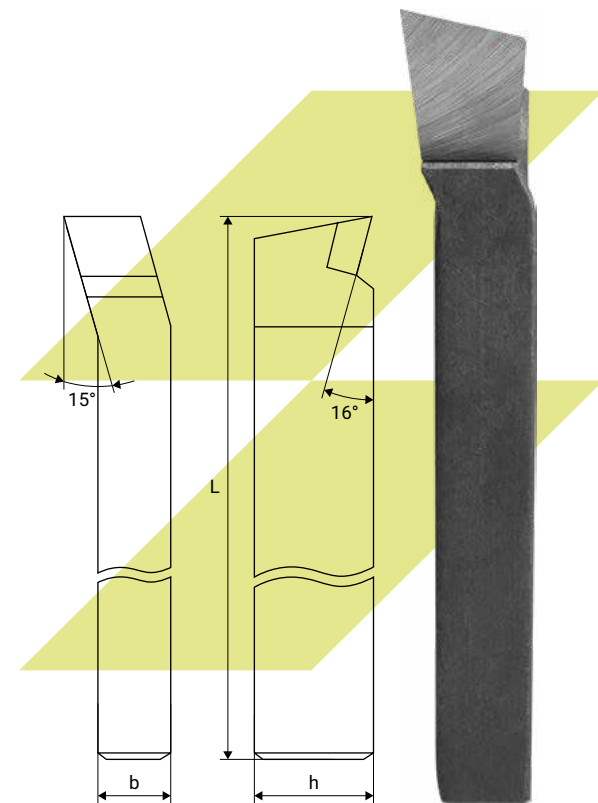

Резцы подрезные торцовые с пластинами из быстрорежущей стали

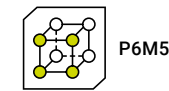

Артикул	Обозначение по ГОСТ	h, мм	b, мм	L, мм
1846979	2112-0032	16	10	110
1106384	2112-0034	20	12	125
1846980	2112-0036	25	16	140
1106374	2112-0038	32	20	170
1106392	2112-0040	40	25	200

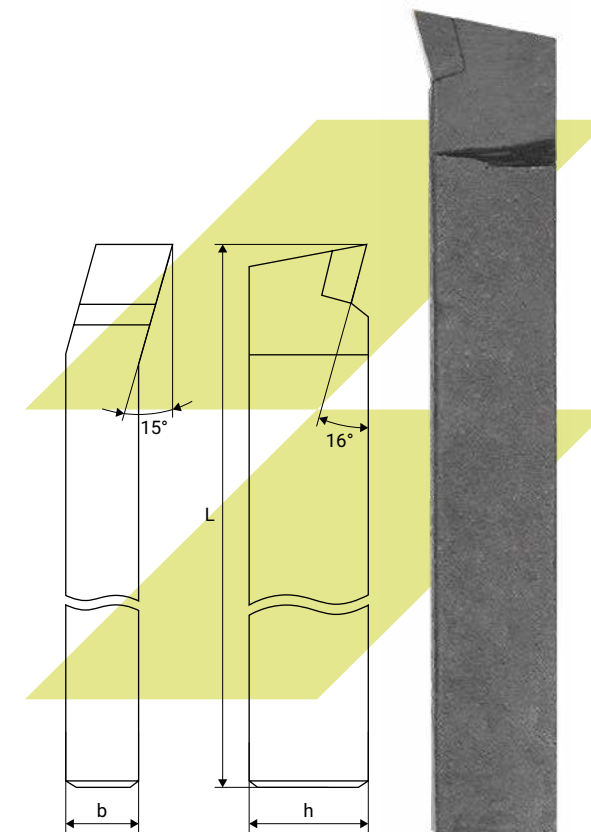

Резцы резьбовые с пластинами из быстрорежущей стали для наружной метрической резьбы

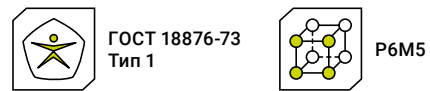

Артикул	Обозначение по ГОСТ	L, мм	P, мм	h, мм	b, мм
1847075	2660-0501	100	0,50–2,50	16	10
1847076	2660-0503	120	0,75–3,00	20	12
1135197	2660-0505	140	1,00–5,00	25	16
106611	2660-0507	170	1,50–6,00	32	20

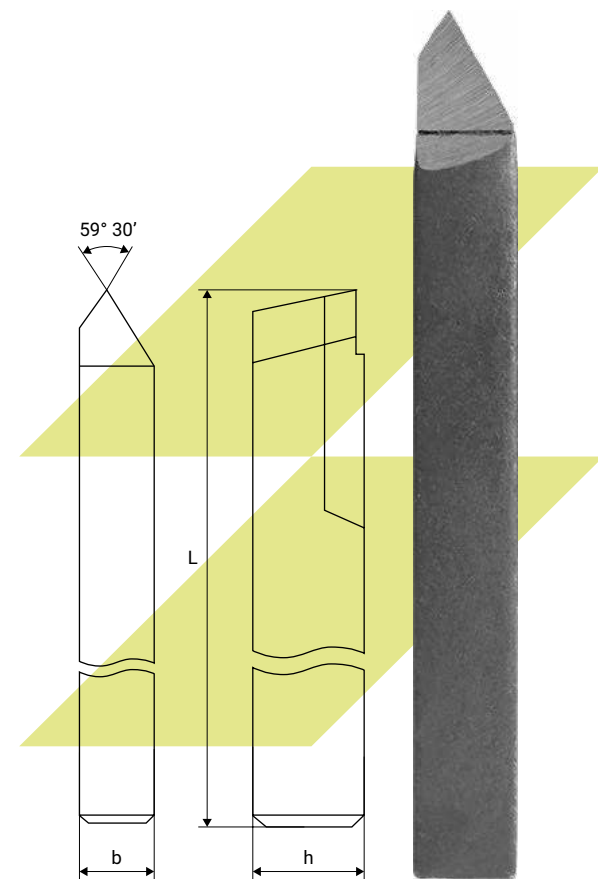

Резцы резьбовые с пластинами из быстрорежущей стали для внутренней метрической резьбы

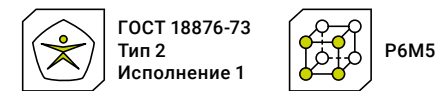

Артикул	Обозначение по ГОСТ	L, мм	P, мм	h, мм	b, мм
1416460	2662-0501	120	0,75–2,50	10	10
1415862	2662-0503	140	1,00–3,00	12	12
1582519	2662-0505	170	1,50–4,00	16	16
1847074	2662-0507	200	2,00–5,00	20	20
1256196	2662-0509	240	3,00–6,00	25	25

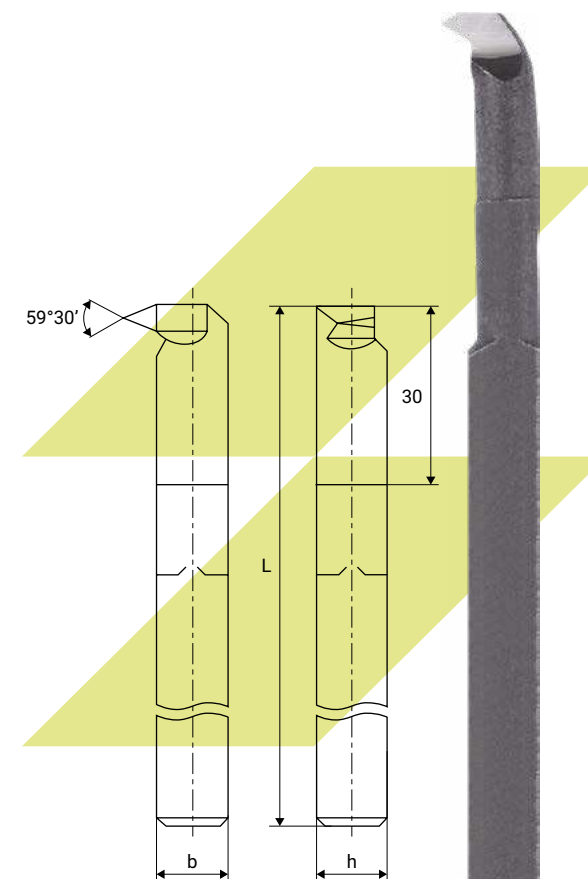

Цельные заготовки для автоматных резцов

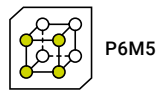

P6M5

Артикул		h, мм	b, мм	L, мм
1240346	●	6	6	200
1335760	●	7	7	150
1584650	●	8	8	70
1377749	●	8	8	150
1417745	●	8	8	200
1331241	●	10	10	100
1331242	●	10	10	120
1331243	●	10	10	150
1136176	●	12	3	100
1220074	●	12	12	150
1377855	●	14	14	150
1582580	●	14	14	200
1220071	●	16	16	150
1582581	●	16	16	200
1136177	●	18	4	125
1582582	●	18	18	150
1518380	●	18	18	200
1220072	●	20	20	150
1220073	●	20	20	200
1128535	●	24	4	180
1582583	●	24	24	300
1582584	●	32	32	320

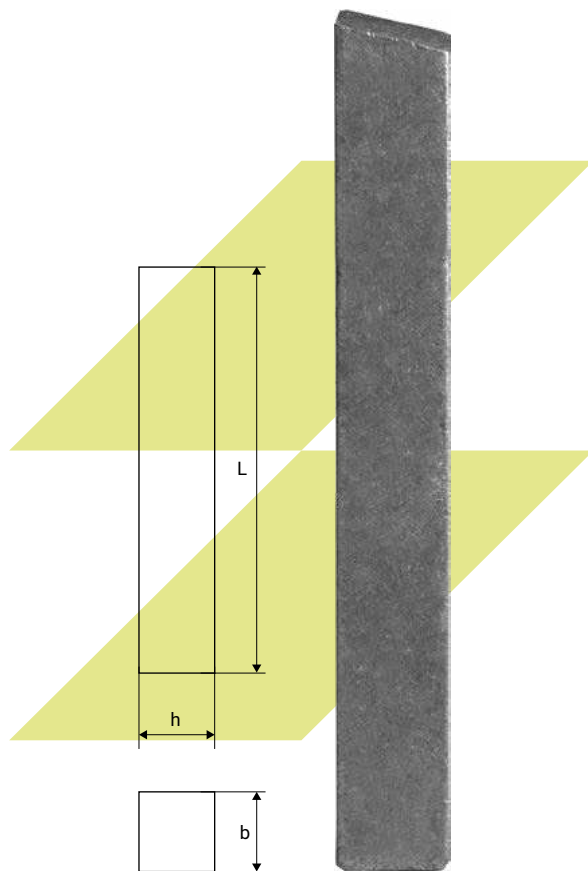

Резцы долбежные



ГОСТ 10046-72
Тип 2
Исполнение 1

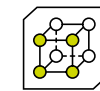

P6M5

Артикул		Обозначение по ГОСТ	h, мм	b, мм	L, мм	a, мм
116557	●	2182-0601	16	10	150	4
116558	●	2182-0602	16	10	150	5
1337848	●	2182-0603	20	12	250	6

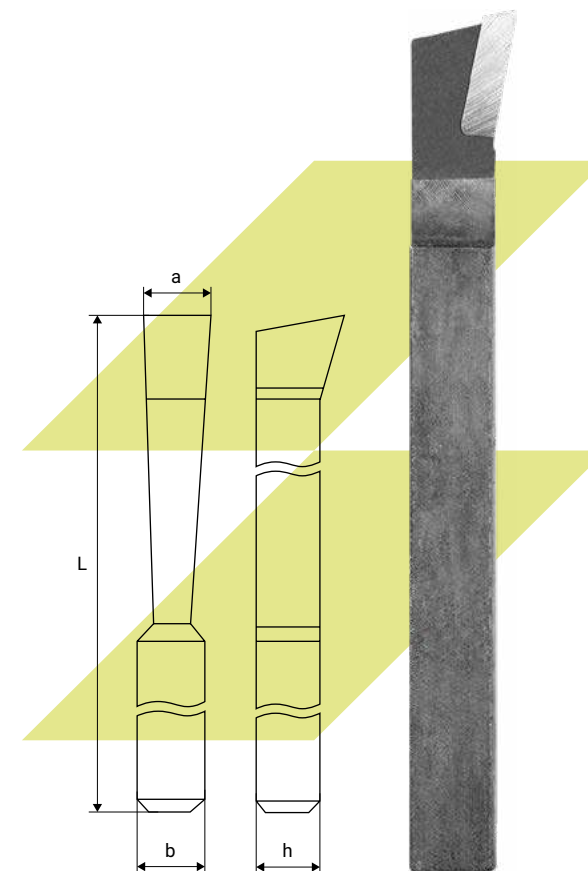

Резцы долбежные

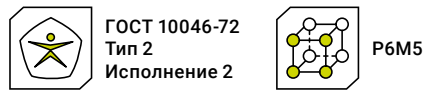

Артикул	Обозначение по ГОСТ	h, мм	b, мм	L, мм	a, мм
1337849	2182-0604	20	12	250	8
1108767	2182-0605	25	16	300	10
1108768	2182-0606	25	16	300	12
116223	2182-0607	32	20	350	14
116559	2182-0608	32	20	350	16
1127499	2182-0609	40	25	400	18
116561	2182-0610	50	32	500	20
116562	2182-0611	50	32	500	24

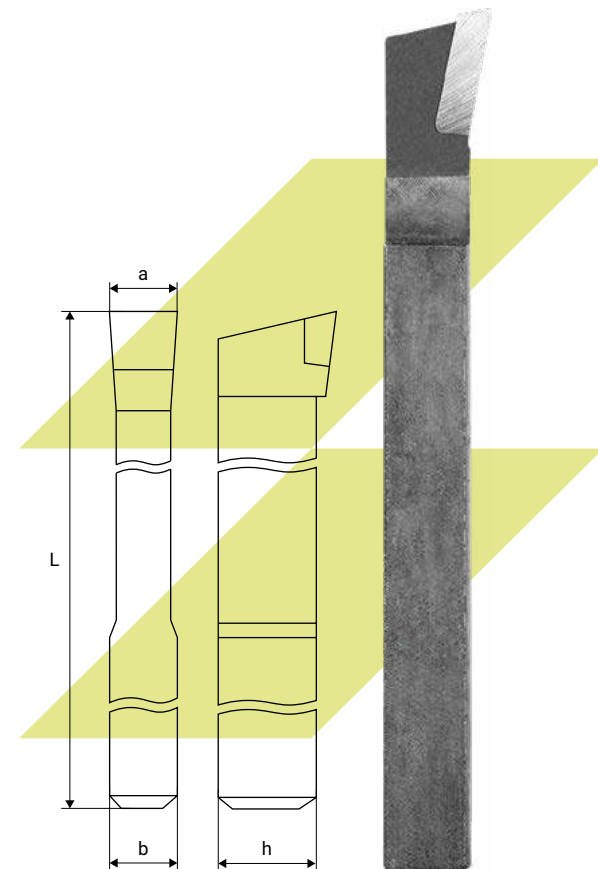

Резцы долбежные для шпоночных пазов

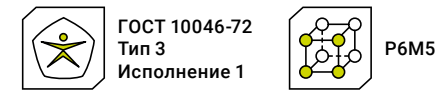

Артикул	Обозначение по ГОСТ	h, мм	b, мм	L, мм	a, мм
106176	2184-0554	20	20	280	6
1257887	2184-0555	25	25	300	8
1257886	2184-0556	25	25	350	10
1268399	2184-0557	32	32	400	12
1331003	2184-0558	32	32	400	14

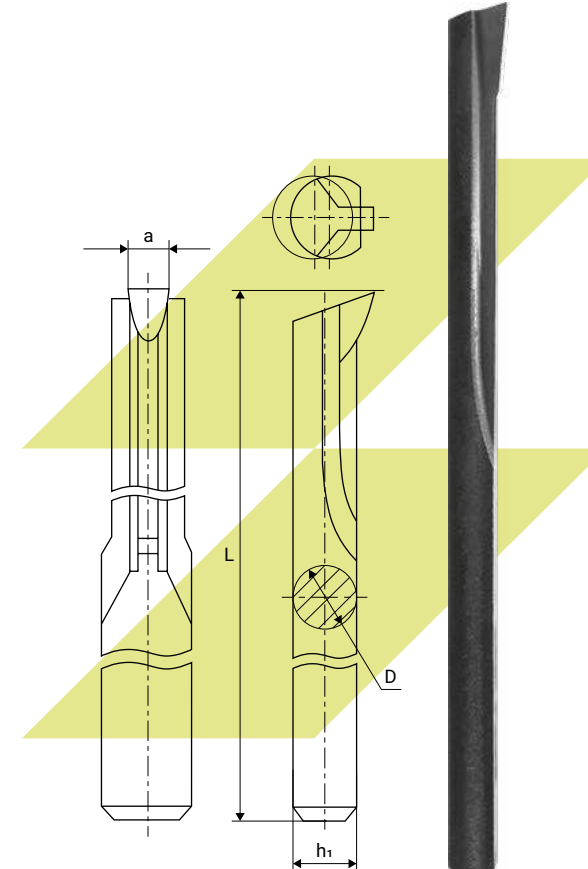

Резцы долбежные для шпоночных пазов

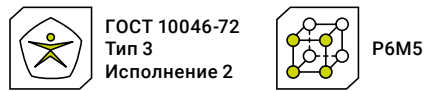

Артикул	Обозначение по ГОСТ	h, мм	L, мм	a, мм
106190	2184-0551	Ø6	90	3
1108777	2184-0552	Ø8	100	4
1108778	2184-0553	Ø12	110	5

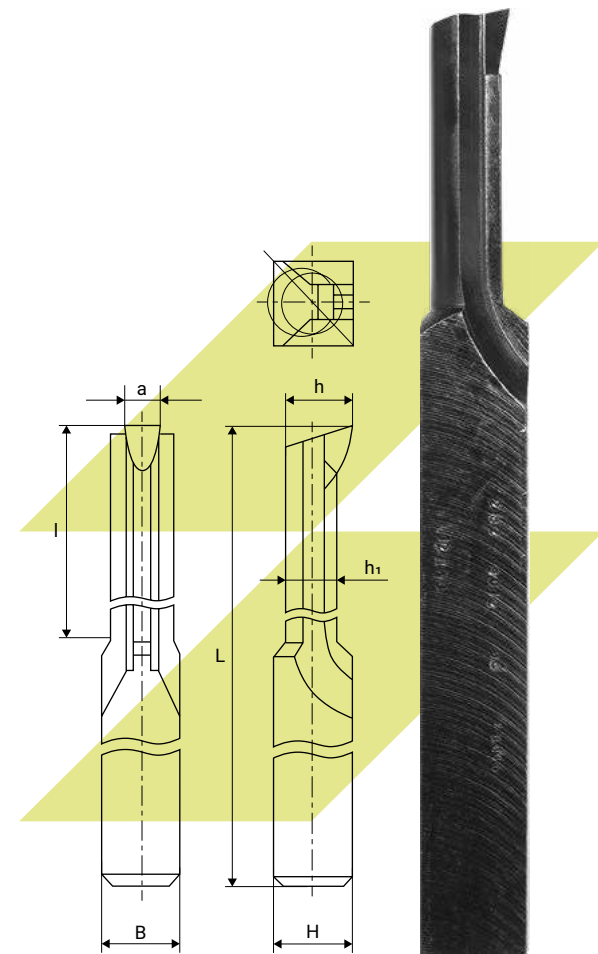

Резцы долбежные для шпоночных пазов

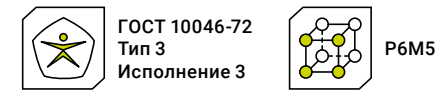

Артикул	Обозначение по ГОСТ	h, мм	b, мм	L, мм	a, мм
106177	2184-0571	20	20	300	10
106178	2184-0572	20	20	300	12
106184	2184-0573	25	25	350	14
106185	2184-0574	25	25	350	16
1416318	2184-0575	32	32	350	18
1268400	2184-0576	32	32	400	20
1377779	2184-0577	40	40	450	20

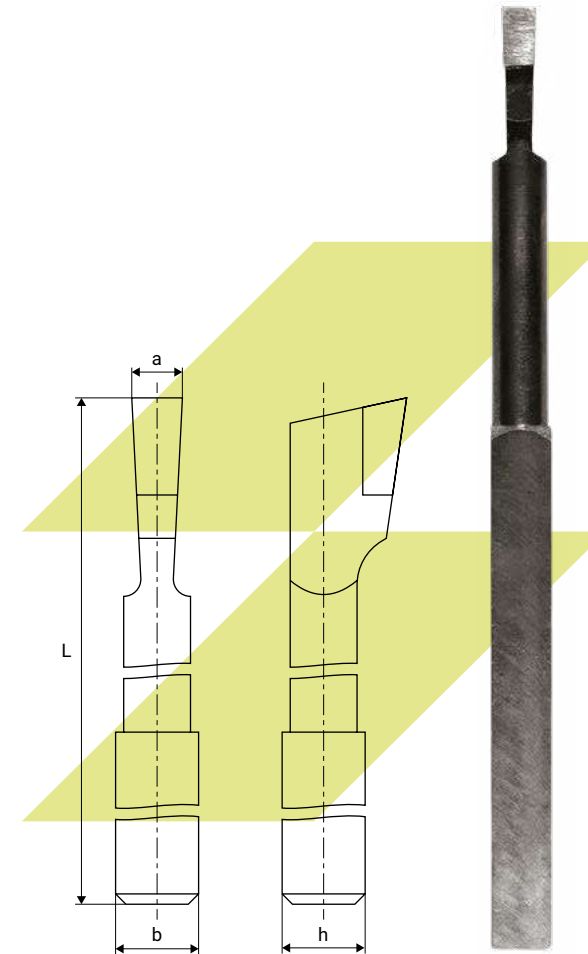

Пластины для отрезки и обработки канавок MGGN/MGMN

IPG300



Артикул	IPG300	Обозначение	r, мм	b, мм	f, мм/об
1613339	●	MGGN150-GP	0,15	1,5	0,02–0,04
1531807	●	MGGN200-GP	0,2	2	0,02–0,07
1613340	●	MGGN250-GP	0,2	2,5	0,03–0,10
1531808	●	MGGN300-GP	0,4	3	0,04–0,13
1531809	●	MGGN400-GP	0,4	4	0,05–0,17

MG..N	L, мм	S, мм
150	16	3,5
200	16	3,5
250	18,5	3,85
300	21	4,8
400	21	4,8

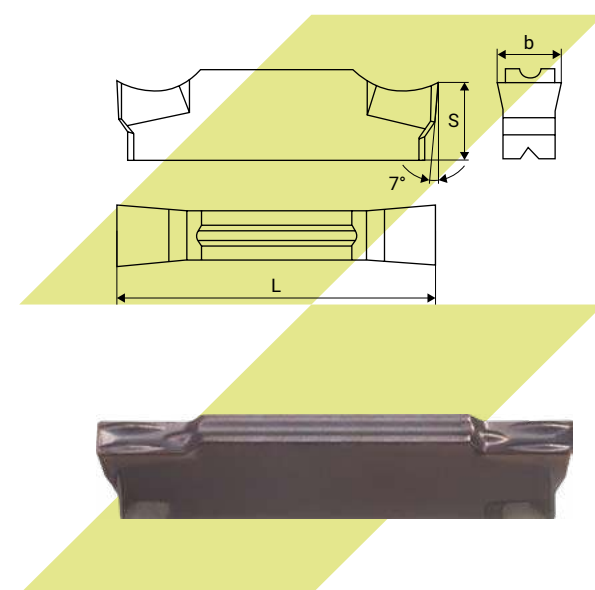

Пластины для отрезки и обработки канавок MGGN/MGMN

IPG300



ITN250



ICP250



Артикул	IPG300	ITN250	ICP250	Обозначение	r, мм	b, мм	f, мм/об
1613341	●	○	○	MGMN150-PG1	0,15	1,5	0,02–0,04
1613342	○	●	○	MGMN150-PG1	0,2	2,5	0,02–0,04
1613343	○	○	●	MGMN200-PG1	0,2	2	0,02–0,07
1613344	●	○	○	MGMN200-PG1	0,2	2	0,02–0,07
1613346	○	●	○	MGMN200-PG1	0,2	2	0,02–0,07
1613347	○	○	●	MGMN250-PG1	0,2	2,5	0,03–0,10
1613345	●	○	○	MGMN250-PG1	0,2	2,5	0,03–0,10
1613348	○	●	○	MGMN250-PG1	0,2	2,5	0,03–0,10
1531802	●	○	○	MGMN300-P	0,4	3	0,04–0,13
1613349	○	○	●	MGMN300-PG	0,4	3	0,04–0,13
1531804	●	○	○	MGMN300-PG	0,4	3	0,04–0,13
1613350	○	●	○	MGMN300-PG	0,4	3	0,04–0,13
1613351	●	○	○	MGMN300-PG2	0,4	3	0,04–0,13
1531803	●	○	○	MGMN400-P	0,4	4	0,04–0,13
1613352	○	○	●	MGMN400-PG	0,4	4	0,04–0,13
1531805	●	○	○	MGMN400-PG	0,4	4	0,04–0,13
1613353	○	●	○	MGMN400-PG	0,4	4	0,04–0,13
1613354	●	○	○	MGMN400-PG2	0,4	4	0,04–0,13
1613355	○	○	●	MGMN500-PG	0,8	5	0,08–0,23
1531806	●	○	○	MGMN500-PG	0,8	5	0,08–0,23
1613356	○	●	○	MGMN500-PG	0,8	5	0,08–0,23
1613357	●	○	○	MGMN600-PG	0,8	6	0,12–0,27

MG..N	L, мм	S, мм
150	16	3,5
200	16	3,5
250	18,5	3,85
300	21	4,8
400	21	4,8
500	26	5,8
600	26	5,8

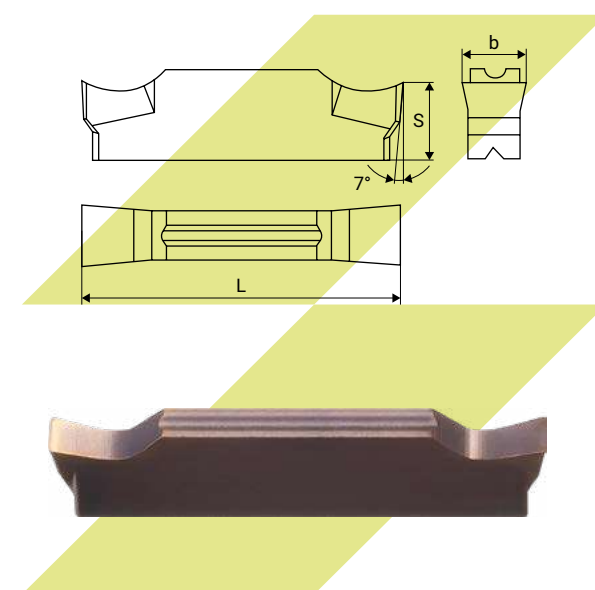

Пластины для наружного точения и профильной обработки канавок MRMN

IPP250



Артикул	IPP250	Обозначение	r, мм	b, мм	f, мм/об
1613358	●	MRMN200-PG	1	2	0,03–0,10
1613359	●	MRMN300-PG	1,5	3	0,04–0,13
1613360	●	MRMN400-PG	2	4	0,06–0,18

MR..N	L, мм	S, мм
200	16	3,5
300	21	4,8
400	21	4,8

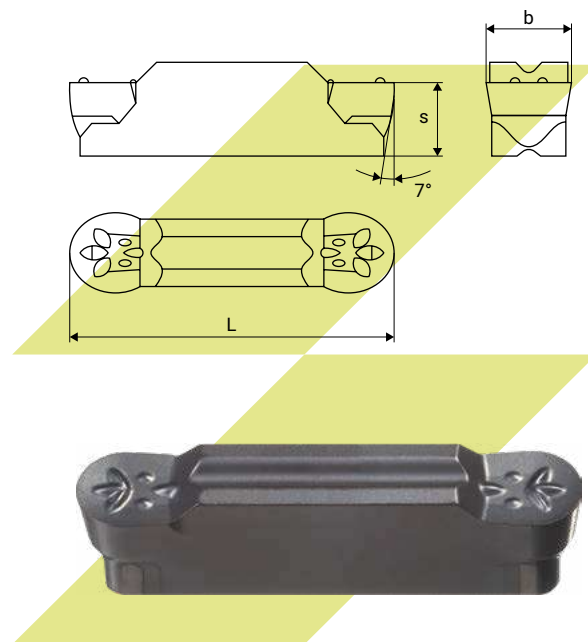

Токарные пластины CNMG

IPG301



ICP250



Артикул	IPG301	ICP250	Обозначение	r, мм	ap, мм	f, мм/об
1531816	●	○	CNMG 120404-MP2	0,4	0,40–5,50	0,10–0,30
1531814	○	●	CNMG 120408-MP2	0,8	0,50–5,50	0,15–0,50
1613331	○	●	CNMG 120412-MP2	1,2	0,80–5,50	0,18–0,60

CN..G	L, мм	I.C., мм	S, мм	d, мм
1204	12,9	12,7	4,76	5,16

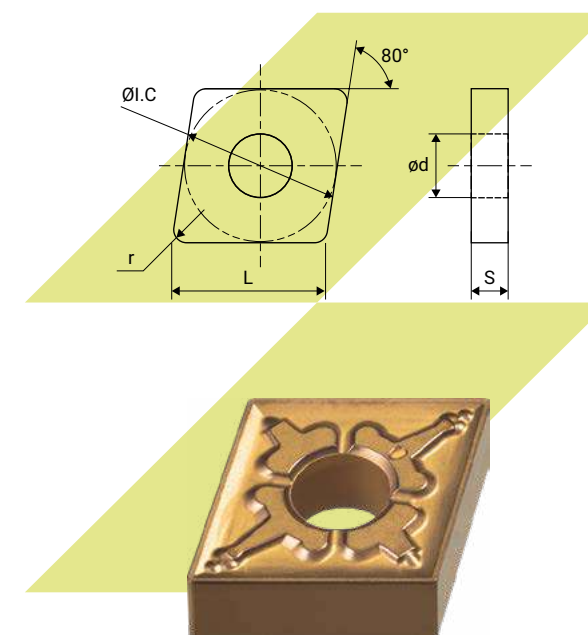

Токарные пластины DCMT

IPG300



Артикул	IPG300	Обозначение	r, мм	ap, мм	f, мм/об
1613333	●	DCMT 070208-MM3	0,8	0,15–1,70	0,08–0,25
1613334	●	DCMT 11T308-MM	0,8	0,15–2,00	0,08–0,30

DC..T	L, мм	I.C., мм	S, мм	d, мм
0702	7,8	6,35	2,38	2,8
11T3	11,6	9,525	3,97	4,4

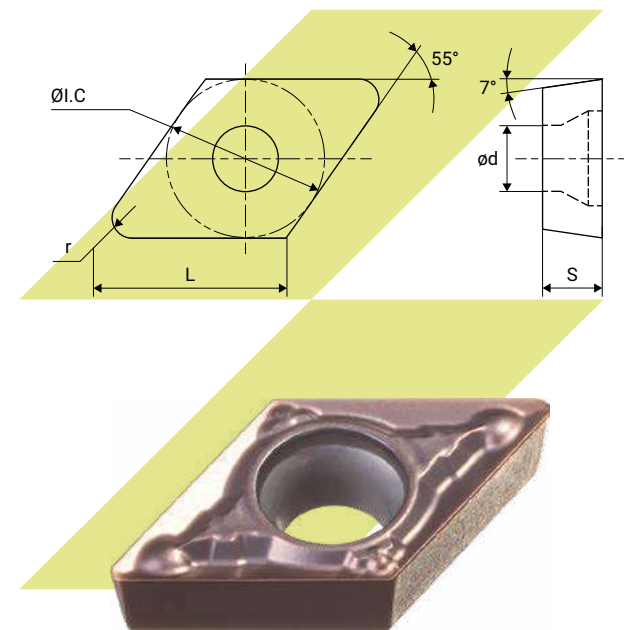

Токарные пластины DNMG

ICP250



Артикул	ICP250	Обозначение	r, мм	ap, мм	f, мм/об
1613335	●	DNMG 150404-MP2	0,4	0,40–6,00	0,10–0,30
1613336	●	DNMG 150408-MP2	0,8	0,50–6,00	0,15–0,50
1613337	●	DNMG 150604-MP1	0,4	0,40–6,00	0,10–0,30
1531822	●	DNMG 150608-MP1	0,8	0,50–6,00	0,15–0,50
1613338	●	DNMG 150612-MP1	1,2	0,80–6,00	0,18–0,60

DN..G	L, мм	I.C., мм	S, мм	d, мм
1504	15,5	12,7	4,76	5,16
1506	15,5	12,7	6,35	5,16

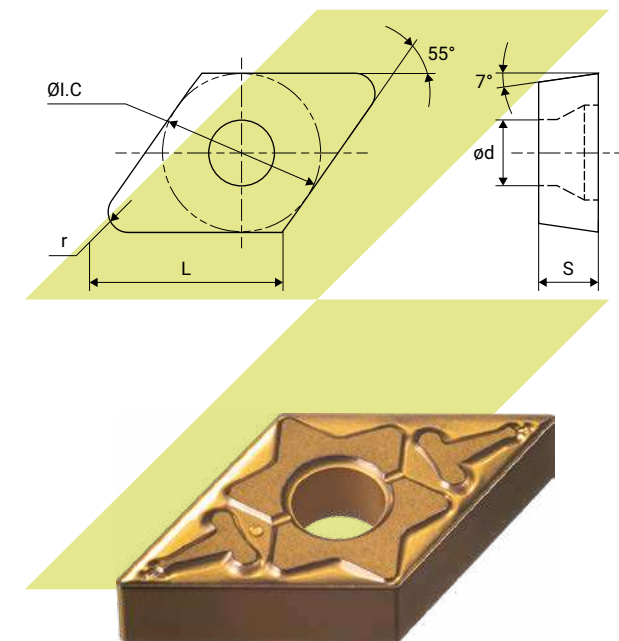

Токарные пластины SCMT

IPG300



Артикул	IPG300	Обозначение	r, мм	ap, мм	f, мм/об
1613361	●	SCMT 09T304-MM	0,4	0,11–2,00	0,06–0,20

SC..T	L, мм	I.C., мм	S, мм	d, мм
09T3	9,525	9,525	3,97	4,4

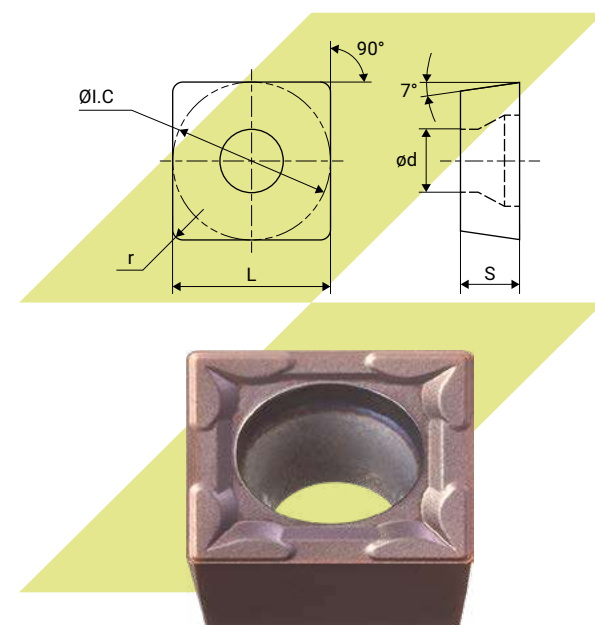

Токарные пластины TCMT

IPG300



Артикул	IPG300	Обозначение	r, мм	ap, мм	f, мм/об
1613366	●	TCMT 110208-MM	0,8	0,15–2,00	0,08–0,30
1613367	●	TCMT 16T304-MM	0,4	0,25–3,00	0,08–0,23
1613368	●	TCMT 16T308-MM	0,8	0,5–3,0	0,1–0,3

TC..T	L, мм	I.C., мм	S, мм	d, мм
1102	11	6,35	2,38	2,8
16T3	16,5	9,525	3,97	4,4

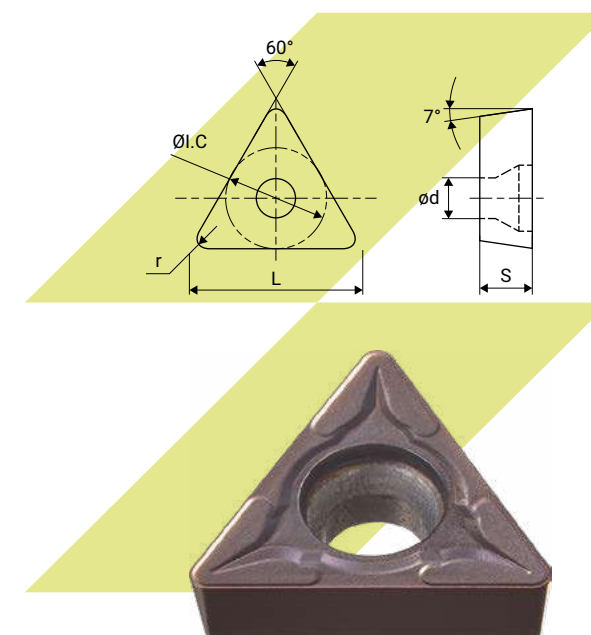

Токарные пластины TNMG

IPG301



ICP250



Артикул	IPG301 ICP250	Обозначение	r, мм	ap, мм	f, мм/об
1613369	● ○	TNMG 160404-MM1	0,4	0,40–4,80	0,06–0,30
1613370	○ ●	TNMG 160404-MP2	0,4	0,40–5,00	0,10–0,30
1613371	● ○	TNMG 160408-MM1	0,8	0,05–4,80	0,10–0,45
1613372	○ ●	TNMG 160408-MP2	0,8	0,50–5,00	0,15–0,50
1531812	○ ●	TNMG 220412-MP1	1,2	0,80–6,60	0,18–0,60

TN..G	L, мм	I.C., мм	S, мм	d, мм
1604	16,5	9,525	4,76	3,81
2204	22	12,7	4,76	5,16

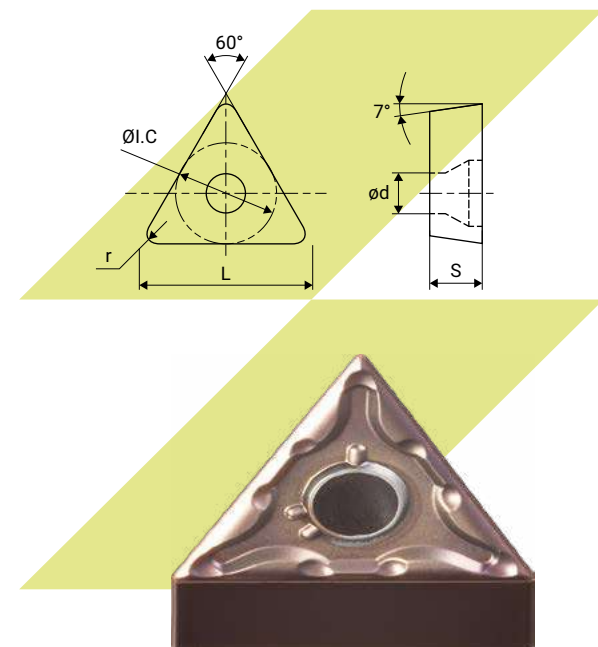

Токарные пластины VBMT

IPG300



Артикул	IPG300	Обозначение	r, мм	ap, мм	f, мм/об
1613374	●	VBMT 160404-MM3	0,4	0,11–2,00	0,06–0,20
1613375	●	VBMT 160408-MM3	0,8	0,15–2,00	0,08–0,30

VB..T	L, мм	I.C., мм	S, мм	d, мм
1604	16,5	9,525	4,76	4,4

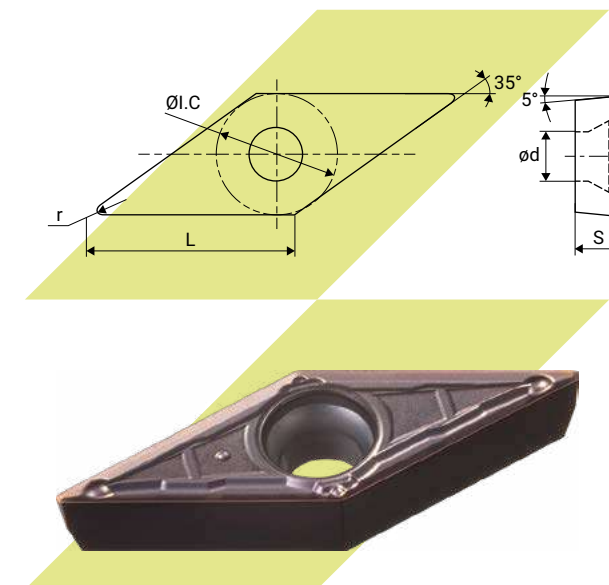

Токарные пластины VNMG

IPG300



IPG301



ICP250



Артикул	IPG300 IPG301 ICP250	Обозначение	r, мм	ap, мм	f, мм/об
1613377	● ● ●	VNMG 160404-MP2	0,4	0,40–4,00	0,10–0,30
1531820	● ● ●	VNMG 160408-MP2	0,8	0,50–4,00	0,15–0,50
1613378	● ● ●	VNMG 160412-MP2	1,2	0,80–4,00	0,18–0,60

VN..G	L, мм	I.C., мм	S, мм	d, мм
1604	16,6	9,525	4,76	3,81

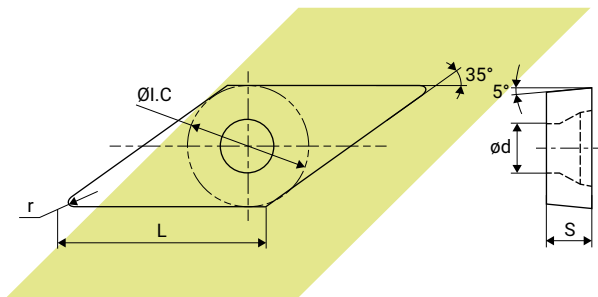

Токарные пластины WNMG

IPG301



ICP250



Артикул	IPG301 ICP250	Обозначение	r, мм	ap, мм	f, мм/об
1531817	● ● ●	WNMG 060408-MP2	0,8	0,50–3,00	0,15–0,50
1613381	● ● ●	WNMG 080404-MP2	0,4	0,40–4,00	0,10–0,30
1531818	● ● ●	WNMG 080408-MP1	0,8	0,30–2,00	0,10–0,35
1613382	● ● ●	WNMG 080408-MP2	0,8	0,50–4,00	0,15–0,50
1613383	● ● ●	WNMG 080412-MP2	1,2	0,80–4,00	0,18–0,60

VN..G	L, мм	I.C., мм	S, мм	d, мм
0604	6,5	9,525	4,76	3,81
0804	8,7	12,7	4,76	5,16

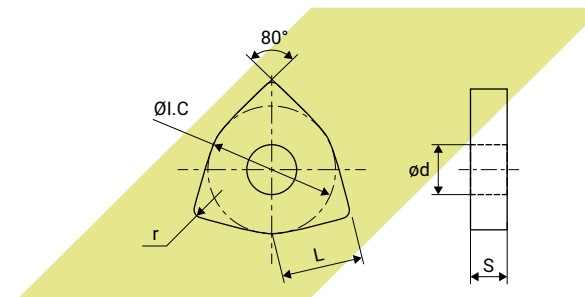

Токарные пластины WNMG

IPG301



ICP250



Артикул	IPG301	ICP250	Обозначение	r, мм	ap, мм	f, мм/об
1613380	●	●	WNMG 080404-MM1	0,4	0,40–4,00	0,06–0,30
1531819	●	●	WNMG 080408-MM1	0,8	0,05–4,00	0,10–0,45

VN..G	L, мм	I.C., мм	S, мм	d, мм
0804	8,7	12,7	4,76	5,16

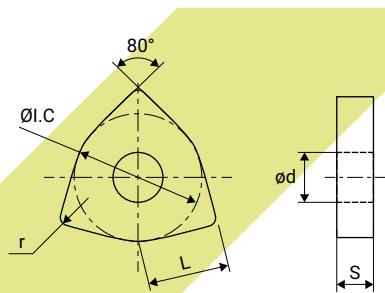

Токарные резьбовые пластины для нарезания наружной резьбы

IPP250



Артикул	IPP250	Обозначение	Шаг		X, мм	Y, мм
			мм	TPI		
1613295	●	11ER A60*	0,50–1,50	48–16	0,9	0,8
1613296	●	11ER1.0ISO	1,00	–	0,7	0,6
1613297	●	11ER1.25ISO	1,25	–	0,8	0,8
1613298	●	11ER1.50ISO	1,50	–	1,0	0,8
1613307	●	16ER A60*	0,50–1,50	48–16	0,9	0,8
1613308	●	16ER AG60*	0,50–0,30	48-8	0,9	0,8
1613309	●	16ER G60*	1,75–3,00	14–8	1,7	1,2
1613310	●	16ER0.5ISO	0,50	–	0,6	0,6
1613311	●	16ER0.75ISO	0,75	–	0,6	0,6
1613312	●	16ER1.0ISO	1,00	–	0,7	0,6
1613313	●	16ER1.25ISO	1,25	–	0,9	0,8
1613314	●	16ER1.5ISO	1,50	–	1,0	0,8
1613315	●	16ER1.75ISO	1,75	–	1,2	0,9
1613316	●	16ER2.0ISO	2,00	–	1,3	1,0
1613317	●	16ER2.5ISO	2,50	–	1,5	1,1
1613318	●	16ER3.0ISO	3,00	–	1,5	1,1

Размер пластины	L, мм	I.C., мм
11	11	6,350
16	16	9,525

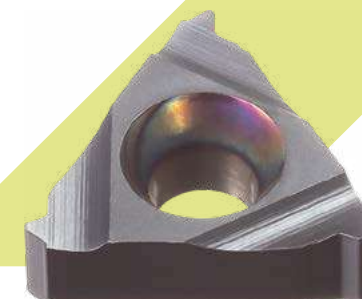
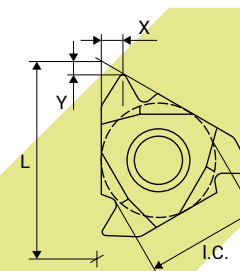

Токарные резьбовые пластины для нарезания внутренней резьбы

IPP250



Артикул	IPP250	Обозначение	Шаг		X, мм	Y, мм
			мм	TPI		
1613299	●	11IR A60*	0,50–1,50	48–16	0,9	0,8
1613300	●	11IR0.50ISO	1,00	–	0,7	0,6
1613301	●	11IR0.75ISO	1,25	–	0,8	0,8
1613302	●	11IR1.00ISO	1,50	–	1,0	0,8
1613303	●	11IR1.25ISO	0,50–1,50	48–16	0,9	0,8
1613304	●	11IR1.50ISO	0,50	–	0,6	0,6
1613305	●	11IR1.75ISO	0,75	–	0,6	0,6
1613306	●	11IR2.00ISO	1,00	–	0,7	0,6
1613319	●	16IR0.50ISO	1,75	–	1,2	0,9
1613320	●	16IR0.75ISO	2,00	–	1,3	1,0
1613321	●	16IR1.00ISO	2,50	–	1,5	1,1
1613322	●	16IR1.25ISO	3,00	–	1,5	1,1
1613323	●	16IR1.50ISO	0,50	–	0,6	0,6
1613324	●	16IR1.75ISO	0,75	–	0,6	0,6
1613325	●	16IR2.00ISO	1,00	–	0,7	0,6
1613326	●	16IR2.50ISO	1,25	–	0,9	0,8
1613327	●	16IR3.00ISO	1,50	–	1,0	0,8

Размер пластины	L, мм	I.C., мм
11	11	6,350
16	16	9,525

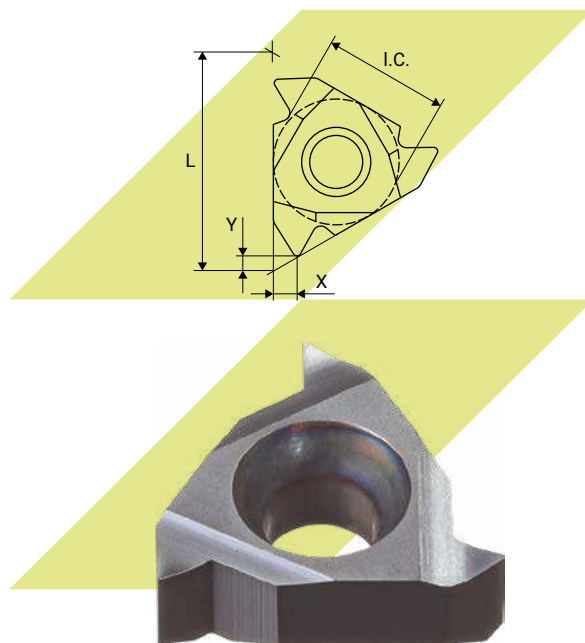

Для заметок

Blank lined area for notes.

Обработка отверстий

Свёрла	128
Спиральные из быстрорежущей стали	128
Спиральные твердосплавные	188
Центровочные	208
Сборные с механическим креплением пластин	217
Свёрла ступенчатые	219
Свёрла по дереву	221
Свёрла по кафелю и стеклу	223
Наборы свёрл	224
Зенкеры	226
Зенкеры ЦХ	226
Зенкеры КХ	227
Развёртки	230
Ручные	230
Ручные конические	246
Машинные твердосплавные	257
Машинные из быстрорежущей стали	264
Зенковки	286
Центровочные	286
С цилиндрическим хвостовиком	290
С коническим хвостовиком	293

Свёрла

Свёрла применяются для сверления отверстий в различных материалах, могут также использоваться для рассверливания и засверливания. Используются в ручных дрелях, перфораторах и сверлильных станках. Отличаются повышенной прочностью и высокой износостойкостью, длительное время не теряют режущих свойств при нагреве и устойчивы к излому. Подходят для высокоскоростной обработки.



Зенкеры

Зенкеры используются для обработки металла, древесины, пластика и чугуна. Идеально подходят для черных и цветных металлов. Применяются для выполнения цилиндрических отверстий в деталях с целью увеличения их диаметра и повышения качества поверхности и точности.



Развёртки

Развёртки предназначены для заглаживания поверхности высверленных отверстий. Используются для окончательной обработки отверстий в деталях из стали после их сверления, растачивания или зенкерования. Обладают высокими прочностными характеристиками, стойкостью к коррозии и перепадам температур. Имеют высокую точность и обеспечивают снятие слоя металла минимальной толщины. Использование разверток позволяет добиться высокого класса шероховатости стенок отверстия и точности его геометрии.



Зенковки

Зенковки применяются для обработки просверленных отверстий под головки болтов, винтов и заклёпок: получения сквозных и глухих отверстий в заготовках, создания опорных плоскостей вокруг отверстий или снятия фасок. Подходят для обработки заготовок, выполненных из легированной стали, чугуна, алюминия, меди, бронзы, цинка.



Условные обозначения

Основные размеры

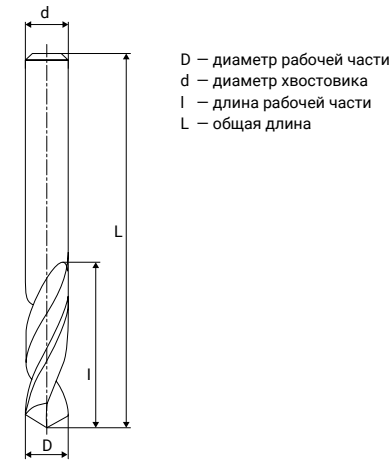

- Обозначение стандарта
- Обозначение инструментального материала
- Класс точности/Квалитет
- Угол при вершине
- Угол наклона винтовой канавки
- Конусность
- Тип зенковки
- Применение

Тип обработки

- Для сквозных отверстий
- Для глухих отверстий
- Для сквозных конических отверстий
- Для глухих конических отверстий
- Для центровочных отверстий у свёрл тип А
- Для центровочных отверстий у свёрл тип В

Серия инструмента

- Короткая
- Средняя
- Длинная
- Сверхдлинная

Полировка инструмента

- Полированное
- Неполированное

Наличие инструмента

- На складе в Нижнем Новгороде
- Под заказ

Обрабатываемый материал

- P Стали
- M Нержавеющая сталь
- K Чугуны
- N Цветные металлы
- S Жаропрочные сплавы
- H Закаленная сталь
- Оптимальное применение
- Возможное применение
- Не применяется

Направление резания

- Правое
- Левое

Стружечная канавка

- Прямая
- Винтовая

Свёрла спиральные с цилиндрическим хвостовиком из быстрорежущей стали

	Средняя серия					
Вид обработки						
Глубина Сверления	~8 x D	~8 x D	~8 x D	~8 x D	~8 x D	~8 x D
Направление Резания	Правое	Правое	Правое	Правое	Правое	Левое
Стандарт	ГОСТ 10902-77	ГОСТ 10902-77	ГОСТ 10902-77	ГОСТ 10902-77	ГОСТ 10902-77	ГОСТ 10902-77
Материал	P6M5	P6M5	P6M5K5	P18	HSS	P6M5
Диапазон	0,43–20,0	0,24–20,0	0,5–20,0	0,25–20,0	0,3–20,0	0,7–20,0
Страница	128	131	135	138	141	145

	Короткая серия			Длинная серия			
Вид обработки							
Глубина Сверления	~3 x D	~3 x D	~3 x D	~12 x D	~12 x D	~12 x D	~12 x D
Направление Резания	Правое	Левое	Левое	Правое	Правое	Правое	Правое
Стандарт	ГОСТ 4010-77	ГОСТ 4010-77	ГОСТ 4010-77	ГОСТ 886-77	ГОСТ 886-77	ГОСТ 886-77	ГОСТ 886-77
Материал	P6M5	P6M5	P18	P6M5	P6M5	P6M5K5	P18
Диапазон	0,5–22,0	0,8–19,0	0,2–20,0	1,1–20,0	1,0–9,7	1,3–20,0	1,0–20,0
Страница	148	151	153	154	157	159	161

Свёрла спиральные с цилиндрическим хвостовиком из быстрорежущей стали

	Сверхдлинные	Малоразмерные диаметром от 0,1 до 1,5 мм с утолщенным цилиндрическим хвостовиком			
Вид обработки					
Глубина Сверления	~20-50 x D	~6 x D	~10 x D	~6 x D	~10 x D
Направление Резания	Правое	Правое	Правое	Левое	Левое
Стандарт	ISO 3292	ГОСТ 8034-76	ГОСТ 8034-76	ГОСТ 8034-76	ГОСТ 8034-76
Материал	P6M5	P6M5	P6M5	P6M5	P6M5
Диапазон	2,0–12,0	0,105–1,500	0,110–1,100	0,2–0,9	0,15–0,90
Страница	162	164	166	168	169

Свёрла спиральные с коническим хвостовиком из быстрорежущей стали

	Средняя серия				Длинная серия	Удлиненные
Вид обработки						
Глубина Сверления	~8 x D	~8 x D	~8 x D	~8 x D	~12 x D	~16 x D
Направление Резания	Правое	Правое	Правое	Правое	Правое	Правое
Стандарт	ГОСТ 10903-77	ГОСТ 10903-77	ГОСТ 10903-77	ГОСТ 10903-77	ГОСТ 12121-77	ГОСТ 2092-77
Материал	P6M5	P6M5K5	P18	HSS	P6M5	P6M5
Диапазон	3,5–80,0	5,0–80,0	6,0–63,0	6,0–100,0	5,0–31,0	5,0–80,0
Страница	170	174	177	179	182	185

Свёрла спиральные твердосплавные с цилиндрическим хвостовиком

	Укороченные	Короткая серия	Средняя серия			Оснащённые пластинами из твёрдого сплава	
Вид обработки							
Глубина Сверления	~3 x D	~5 x D	~7 x D	~8 x D	~8 x D	~6 x D	~8 x D
Направление Резания	Правое	Правое	Правое	Правое	Правое	Правое	Правое
Стандарт	ГОСТ 17273-71	ГОСТ 17274-71	ГОСТ 17275-71	DIN 338	DIN 338	ГОСТ 22735-77	ГОСТ 22735-77
Материал	ВК8	ВК8	ВК8	ВК8	ВК8	ВК8	ВК8
Диапазон	2,0–4,2	1,0–16,5	3,0–14,0	1,0–12,0	1,05–20,0	3,0–20,0	3,1–16,0
Страница	188	189	192	194	196	198	200

	Для печатных плат			Для печатных плат комбинированные	
Вид обработки					
Хвостовик	2 мм	3 мм	3,175 мм	2 мм	3 мм
Направление Резания	Правое	Правое	Правое	Правое	Правое
Стандарт	ГОСТ 20686-75 (ТУ 2-035-970-84)	ГОСТ 20686-75 (ТУ 2-035-970-84)	ГОСТ 20686-75 (ТУ 2-035-970-84)	ГОСТ 20686-75 (ТУ 2-035-970-84)	ГОСТ 20686-75 (ТУ 2-035-970-84)
Материал	ВК6М	ВК6М	НМ	ВК6М	ВК6М
Диапазон	0,4–2,0	0,4–3,0	0,2–4,9	0,7–1,2	0,8–2,0
Страница	201	202	203	205	206

Свёрла спиральные твердосплавные с коническим хвостовиком

	Оснащённые пластинами из твёрдого сплава
Вид обработки	
Глубина Сверления	~8 x D
Направление Резания	Правое
Стандарт	ГОСТ 22736-77
Материал	ВК8
Диапазон	5,2–50,0
Страница	207

Свёрла центровочные

	Комбинированные						
Вид обработки							
Тип	A	A	A	A	A	A	B
Стандарт	DIN 333 A	ГОСТ 14952-75	ГОСТ 14952-75	ГОСТ 14952-75	ГОСТ 14952-75	ГОСТ 14952-75	ГОСТ 14952-75
Материал	ВК8	P6M5	P6M5	P6M5K5	HSS PM	P18	P6M5
Исполнение	Полированное	Полированное	Неполированное	Полированное	Полированное	Полированное	Неполированное
Диапазон	1,0–6,3	0,5–5,0	1,6–12,0	2,0–3,15	1,0–12,0	0,5–6,3	1,0–10,0
Страница	208	209	210	211	212	213	214

Свёрла центровочные

	Комбинированные	
Вид обработки		
Тип	R	A
Стандарт	ГОСТ 14952-75	ИНСТУЛС
Материал	P6M5	P6M5
Покрытие	Неполированное	Неполированное
Диапазон	1,0–10,0	10,0–12,0
Страница	215	216

Свёрла сборные с механическим креплением пластин из быстрорежущей стали

	Сборные перовые свёрла	Пластины сменные из быстрорежущей стали
Вид обработки		
Стандарт	ТУ2-035-741-81	ГОСТ 25526-82
Материал	–	P6M5
Диапазон	51,0–80,0	25,0–130,0
Страница	217	218

Свёрла ступенчатые

Вид обработки		
Стандарт	–	–
Материал	HSS	P6M5
Покрытие	–	TIN
Диапазон	4,0	4,0–6,0
Страница	219	220



Свёрла по дереву

Вид обработки		
Стандарт	–	–
Материал	9XC	9XC
Тип	Спиральное	Перовое
Диапазон	3,0–13,0	6,0–40,0
Страница	221	222









Свёрла по кафелю и стеклу

Вид обработки	
Стандарт	–
Материал	BK6
Диапазон	3,0–16,0
Страница	223

















Наборы свёрл

	HSS	P6M5
Материал	HSS	P6M5
Класс точности	B	A1
Страница	224	225
		

Зенкеры

	С цилиндрическим хвостовиком для обработки деталей из лёгких сплавов		С коническим хвостовиком	
Вид обработки				
Стандарт	ГОСТ 21579-76	ГОСТ 12489-71	ГОСТ 12489-71	ГОСТ 12489-71
Материал	P6M5	P6M5	P6M5	P6M5
Квалитет	№1/№2	h8	h8	h8
Диапазон	3,0–9,0	10,0–60,0	9,0–49,6	12,0–45,0
Страница	226	227	228	229
				

Развёртки ручные

	Цилиндрические							
Вид обработки								
Стружечная канавка	Прямая	Прямая	Прямая	Прямая	Прямая	Прямая	Прямая	Прямая
Стандарт	ГОСТ 7722-77	ГОСТ 7722-77	ГОСТ 7722-77	ГОСТ 7722-77	ГОСТ 7722-77	ГОСТ 7722-77	ГОСТ 7722-77	ГОСТ 7722-77
Материал	9ХС	9ХС	9ХС	9ХС	P6M5	P6M5	P6M5	P6M5
Квалитет	H7	H8	H9	H10	H7	H8	H8	H9
Диапазон	3,0–60,0	3,0–60,0	3,0–60,0	1,8–23,0	1,0–30,0	1,0–4,0	1,0–4,0	1,0–3,2
Страница	230	232	235	238	240	242	242	244
								

	Конические конусностью 1:30 с цилиндрическим хвостовиком	Конические конусностью 1:50 с цилиндрическим хвостовиком		Конические с цилиндрическим хвостовиком под конусы Морзе	Разжимные
Вид обработки					
Стружечная канавка	Прямая	Прямая	Прямая	Прямая	Прямая
Стандарт	ГОСТ 11184-84	ГОСТ 11177-84	ГОСТ 11177-84	ГОСТ 11182-71	ГОСТ 3509-71
Материал	9ХС	9ХС	P6M5	9ХС	9ХС
Квалитет	Предварительные/чистовые	–	–	Предварительные/чистовые/черновые	–
Конусность	1:30	1:50	1:50	Конусы Морзе	–
Диапазон	13,0–50,0	3,0–50,0	0,6–12,0	№0/№6	8,0–50,0
Страница	246	248	250	252	254
					

Развёртки ручные

	Регулируемые со вставными ножами
Вид обработки	
Стружечная канавка	Прямая
Стандарт	ТУ 2-035-478-76
Материал	65Г
Диапазон	7,75–54,0
Страница	256

Развёртки машинные

	Цельные с цилиндрическим хвостовиком			Цельные с коническим хвостовиком		
Вид обработки						
Стружечная канавка	Прямая	Прямая	Прямая	Прямая	Прямая	Прямая
Стандарт	ГОСТ 1672-2016	ГОСТ 1672-2016	ГОСТ 1672-2016	ГОСТ 1672-2016	ГОСТ 1672-2016	ГОСТ 1672-2016
Материал	P6M5	P6M5	P6M5	P6M5	P6M5	P6M5
Квалитет	H7	H8	H9	H7	H8	H9
Диапазон	1,4–20,0	1,4–20,0	1,4–20,0	6,0–50,0	8,0–50,0	8,0–50,0
Страница	264	265	266	267	268	269

Развёртки машинные твердосплавные

	С цилиндрическим хвостовиком				Оснащённые твердосплавными напаиваемыми пластинами с коническим хвостовиком			
Вид обработки								
Стружечная канавка	Прямая	Прямая	Прямая	Прямая	Прямая	Прямая	Прямая	
Стандарт	ГОСТ 16086-70	ГОСТ 16086-70	ГОСТ 16086-70	ГОСТ 28321-89	ГОСТ 28321-89	ГОСТ 28321-89	ГОСТ 28321-89	
Материал	ВК8	ВК8	ВК8	ВК8	ВК8	ВК8	ВК8	
Квалитет	H7	H8	H9	H7	H8	H9	H11	
Диапазон	4,2–10,0	2,0–10,0	3,0–10,0	10,0–32,0	10,0–32,0	10,0–32,0	10,0–32,0	
Страница	257	258	259	260	261	262	263	

	Цельные с коническим хвостовиком	Котельные	Конические конусностью 1:16 с коническим хвостовиком	Конические конусностью 1:30 с коническим хвостовиком
Вид обработки				
Стружечная канавка	Прямая	Винтовая	Прямая	Прямая
Стандарт	ГОСТ 1672-2016	ГОСТ 18121-2017	ГОСТ 6226-71 (дюймовая)	ГОСТ 6226-71 (трубная)
Материал	P6M5	P6M5	P6M5	P6M5
Квалитет	H10	H11	–	–
Конусность	–	1:10	1:16	1:16
Диапазон	10,0–22,0	6,4–40,0	K1/8"–K2"	Rc1/8"–Rc11/2"
Страница	270	272	274	275

Развёртки машинные

	Конические конусностью 1:50	Конические с коническим хвостовиком под конусы Морзе	Насадные		
Вид обработки					
Стружечная канавка	Прямая	Прямая	Прямая	Прямая	Прямая
Стандарт	ГОСТ 10081-84	ГОСТ 10079-71	ГОСТ 1672-2016	ГОСТ 1672-2016	ГОСТ 1672-2016
Материал	P6M5	P6M5	P6M5	P6M5	P6M5
Квалитет	—	Предварительная/чистовая	H7	H8	H9
Конусность	1:50	Морзе	—	—	—
Диапазон	5,0–25,0	№0/№6	25,0–56,0	26,0–48,0	25,0–48,0
Страница	278	279	281	282	283

	Насадные со вставными ножами	Оправка для насадных развёрток и зенкеров
Вид обработки		
Стружечная канавка	Прямая	—
Стандарт	ГОСТ 883-80	ГОСТ 13044-85
Материал	P6M5	—
Квалитет	H9	—
Диапазон	52,0–100,0	13,0–32,0
Страница	284	285

Зенковки из быстрорежущей стали

	Центровочные				С цилиндрическим хвостовиком		
Стандарт	ГОСТ 14953-80	ГОСТ 14953-80	ГОСТ 14953-80	ГОСТ 14953-80	ГОСТ 14953-80	ГОСТ 14953-80	ГОСТ 14953-80
Угол при вершине	60°	60°	60°	75°	60°	90°	120°
Материал	P6M5	P6M5	P6M5	P6M5	P6M5	P6M5	P6M5
Тип	1	2	3	4	5	6	7
Диапазон	5,0–8,0	5,0–16,0	5,0–25,0	6,3–8,0	8,0–25,0	5,0–25,0	8,0–25,0
Страница	286	287	288	289	290	291	292

	С коническим хвостовиком		
Стандарт	ГОСТ 14953-80	ГОСТ 14953-80	ГОСТ 14953-80
Угол при вершине	60°	90°	120°
Материал	P6M5	P6M5	P6M5
Тип	8	10	11
Диапазон	16,0–80,0	16,0–80,0	16,0–80,0
Страница	293	294	295

Свёрла спиральные с цилиндрическим хвостовиком. Средняя серия. Правые

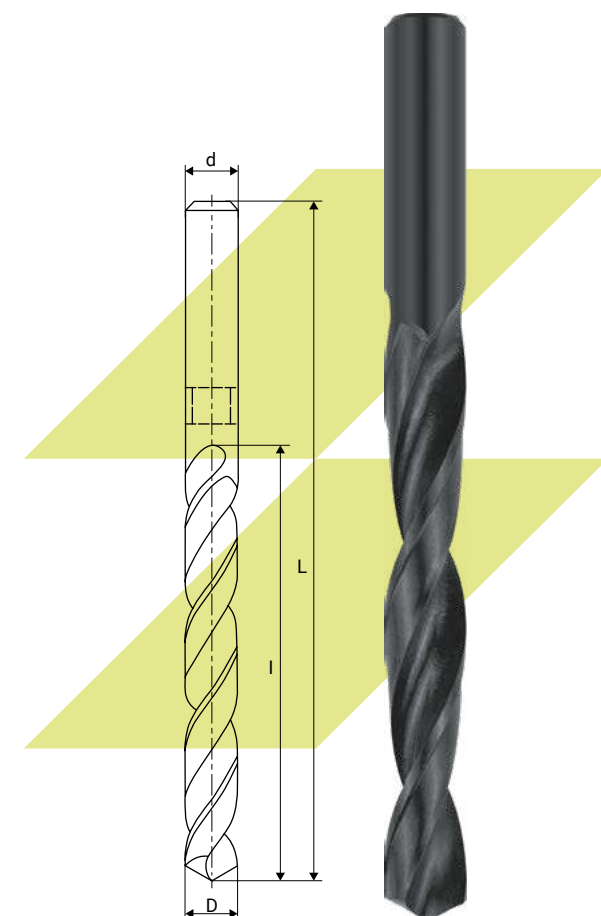
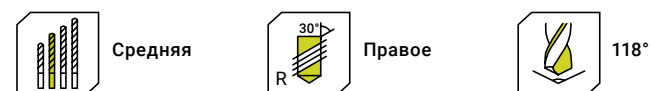
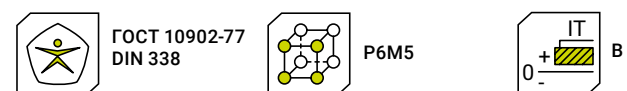

Артикул	Обозначение по ГОСТ	D, мм	d, мм	l, мм	L, мм
1252652	—	0,43	0,43	5,0	20,0
1252653	—	0,44	0,44	5,0	20,0
1252654	—	0,46	0,46	5,0	20,0
1256227	2300-5044	0,58	0,58	7,0	24,0
1177740	2300-0119	0,65	0,65	8,0	26,0
1174025	2300-0120	0,70	0,70	9,0	28,0
1252660	—	0,77	0,77	10,0	30,0
1478670	—	0,91	0,91	11,0	32,0
1252661	2300-0288	0,92	0,92	11,0	32,0
1252662	—	0,93	0,93	11,0	32,0
1167265	2300-0290	1,15	1,15	14,0	36,0
1177745	2300-0131	1,35	1,35	18,0	40,0
1177746	2300-0132	1,40	1,40	18,0	40,0
1177747	2300-0133	1,45	1,45	18,0	40,0
1167291	2300-0292	1,65	1,65	20,0	43,0
1177750	2300-0136	1,70	1,70	20,0	43,0
1167298	2300-0137	1,75	1,75	22,0	46,0
1167303	2300-0138	1,80	1,80	22,0	46,0
1177751	2300-0139	1,90	1,90	22,0	46,0
1167307	2300-0140	1,95	1,95	24,0	49,0
1167314	2300-0141	2,00	2,00	24,0	49,0
1220848	2300-0142	2,05	2,05	24,0	49,0
1173984	2300-0143	2,10	2,10	24,0	49,0
1173985	2300-0144	2,15	2,15	27,0	53,0
1173986	2300-0145	2,20	2,20	27,0	53,0
1173987	2300-0294	2,25	2,25	27,0	53,0
1167328	2300-0146	2,30	2,30	27,0	53,0
1167330	2300-0295	2,35	2,35	27,0	53,0
1173988	2300-0296	2,45	2,45	30,0	57,0
1167343	2300-0148	2,50	2,50	30,0	57,0
1173989	2300-0149	2,55	2,55	30,0	57,0
1261557	2300-0150	2,60	2,60	30,0	57,0
1173990	2300-0151	2,65	2,65	30,0	57,0
1582612	2300-0152	2,70	2,70	33,0	61,0

Артикул	Обозначение по ГОСТ	D, мм	d, мм	l, мм	L, мм
1220849	2300-0297	2,75	2,75	33,0	61,0
1167359	2300-0153	2,80	2,80	33,0	61,0
1173991	2300-0298	2,85	2,85	33,0	61,0
1220850	2300-0154	2,90	2,90	33,0	61,0
1173992	2300-0299	2,95	2,95	33,0	61,0
1167371	2300-7515	3,00	3,00	33,0	61,0
1167381	2300-7517	3,10	3,10	36,0	65,0
1167380	2300-7521	3,15	3,15	36,0	65,0
1167387	2300-7523	3,20	3,20	36,0	65,0
1167399	2300-7525	3,30	3,30	36,0	65,0
1177752	2300-7527	3,35	3,35	36,0	65,0
1167406	2300-7531	3,40	3,40	39,0	70,0
1167415	2300-7533	3,50	3,50	39,0	70,0
1167421	2300-7535	3,60	3,60	39,0	70,0
1167427	2300-7537	3,70	3,70	39,0	70,0
1167431	2300-7541	3,80	3,80	43,0	75,0
1167436	2300-7543	3,90	3,90	43,0	75,0
1167442	2300-7545	4,00	4,00	43,0	75,0
1167451	2300-7547	4,10	4,10	43,0	75,0
1167459	2300-7551	4,20	4,20	43,0	75,0
1173993	2300-7553	4,25	4,25	43,0	75,0
1167469	2300-7555	4,30	4,30	47,0	80,0
1167474	2300-7557	4,40	4,40	47,0	80,0
1167487	2300-7563	4,60	4,60	47,0	80,0
1167490	2300-7565	4,70	4,70	47,0	80,0
1167495	2300-7567	4,80	4,80	52,0	86,0
1173994	2300-7571	4,90	4,90	52,0	86,0
1167508	2300-6173	5,00	5,00	52,0	86,0
1167516	2300-6175	5,10	5,10	52,0	86,0
1167522	2300-6177	5,20	5,20	52,0	86,0
1167528	2300-6181	5,30	5,30	52,0	86,0
1167533	2300-6183	5,40	5,40	57,0	93,0
1167538	2300-6185	5,50	5,50	57,0	93,0
1167543	2300-6187	5,60	5,60	57,0	93,0
1167547	2300-6191	5,70	5,70	57,0	93,0
1167551	2300-6193	5,80	5,80	57,0	93,0
1167555	2300-6195	5,90	5,90	57,0	93,0
1167558	2300-0181	6,00	6,00	57,0	93,0

Артикул	Обозначение по ГОСТ	D, мм	d, мм	l, мм	L, мм
1167564	2300-0182	6,10	6,10	63,0	101,0
1167568	2300-0183	6,20	6,20	63,0	101,0
1167574	2300-0184	6,30	6,30	63,0	101,0
1167577	2300-0307	6,40	6,40	63,0	101,0
1167583	2300-0185	6,50	6,50	63,0	101,0
1167588	2300-0308	6,60	6,60	63,0	101,0
1167592	2300-0186	6,70	6,70	63,0	101,0
1167598	2300-0309	6,80	6,80	69,0	109,0
1167605	2300-0310	6,90	6,90	69,0	109,0
1167611	2300-0187	7,00	7,00	69,0	109,0
1179289	2300-0188	7,10	7,10	69,0	109,0
1172945	2300-0189	7,20	7,20	69,0	109,0
1335745	2300-0190	7,30	7,30	69,0	109,0
1335746	2300-5052	7,40	7,40	69,0	109,0
1335547	2300-0191	7,50	7,50	69,0	109,0
1335747	2300-0192	7,60	7,60	75,0	117,0
1335748	2300-0193	7,70	7,70	75,0	117,0
1335749	2300-0194	7,80	7,80	75,0	117,0
1286966	2300-0311	7,90	7,90	75,0	117,0
1167647	2300-0195	8,00	8,00	75,0	117,0
1167653	2300-0196	8,10	8,10	75,0	117,0
1167656	2300-0197	8,20	8,20	75,0	117,0
1261560	2300-0198	8,30	8,30	75,0	117,0
1167663	2300-0199	8,40	8,40	75,0	117,0
1167667	2300-0200	8,50	8,50	75,0	117,0
1335750	2300-0312	8,60	8,60	81,0	125,0
1179290	2300-0201	8,70	8,70	81,0	125,0
1335751	2300-0313	8,80	8,80	81,0	125,0
1179291	2300-0202	8,90	8,90	81,0	125,0
1167687	2300-0203	9,00	9,00	81,0	125,0
1335752	2300-0314	9,10	9,10	81,0	125,0
1335753	2300-0204	9,20	9,20	81,0	125,0
1335754	2300-0315	9,30	9,30	81,0	125,0
1335755	2300-0316	9,40	9,40	81,0	125,0
1167702	2300-0205	9,50	9,50	81,0	125,0
1335756	2300-0206	9,60	9,60	87,0	133,0
1167709	2300-0207	9,70	9,70	87,0	133,0
1335757	2300-0317	9,80	9,80	87,0	133,0
1335758	2300-0318	9,90	9,90	87,0	133,0

Артикул	Обозначение по ГОСТ	D, мм	d, мм	l, мм	L, мм
1167723	2300-0208	10,00	10,00	87,0	133,0
1167728	2300-0209	10,10	10,10	87,0	133,0
1167731	2300-0210	10,20	10,20	87,0	133,0
1167734	2300-0319	10,30	10,30	87,0	133,0
1167737	2300-0211	10,40	10,40	87,0	133,0
1167742	2300-0212	10,50	10,50	87,0	133,0
1167747	2300-0320	10,60	10,60	87,0	133,0
1179292	2300-0213	10,70	10,70	94,0	142,0
1335759	2300-0321	10,80	10,80	94,0	142,0
1179293	2300-0322	10,90	10,90	94,0	142,0
1167760	2300-0214	11,00	11,00	94,0	142,0
1173995	2300-0323	11,10	11,10	94,0	142,0
1173996	2300-0215	11,20	11,20	94,0	142,0
1173997	2300-0324	11,30	11,30	94,0	142,0
1292981	2300-0325	11,40	11,40	94,0	142,0
1179294	2300-0216	11,50	11,50	94,0	142,0
1167775	2300-5056	11,60	11,60	94,0	142,0
1167776	2300-0217	11,70	11,70	94,0	142,0
1179295	2300-0326	11,80	11,80	94,0	142,0
1173998	2300-0218	11,90	11,90	101,0	151,0
1167786	2300-0219	12,00	12,00	101,0	151,0
1167790	2300-0327	12,10	12,10	101,0	151,0
1167793	2300-0328	12,20	12,20	101,0	151,0
1167797	2300-0329	12,30	12,30	101,0	151,0
1292984	2300-0330	12,40	12,40	101,0	151,0
1173999	2300-0220	12,50	12,50	101,0	151,0
1167803	2300-0331	12,60	12,60	101,0	151,0
1167805	2300-0221	12,70	12,70	101,0	151,0
1167807	2300-0332	12,80	12,80	101,0	151,0
1167811	2300-5061	12,90	12,90	101,0	151,0
1167815	2300-0222	13,00	13,00	101,0	151,0
1518120	2300-0333	13,10	13,10	101,0	151,0
1167822	2300-0334	13,30	13,30	108,0	160,0
1256266	2300-5065	13,40	13,40	108,0	160,0
1167825	2300-0224	13,50	13,50	108,0	160,0
1179296	2300-5069	13,60	13,60	108,0	160,0
1167829	2300-0225	13,70	13,70	108,0	160,0
1261561	2300-5074	13,75	13,75	108,0	160,0

Артикул	Обозначение по ГОСТ	D, мм	d, мм	l, мм	L, мм
1179297	2300-0335	13,80	13,80	108,0	160,0
1174000	2300-5078	13,90	13,90	108,0	160,0
1167838	2300-0226	14,00	14,00	108,0	160,0
1254676	—	14,20	14,20	114,0	169,0
1179298	2300-0227	14,25	14,25	114,0	169,0
1220017	—	14,30	14,30	114,0	169,0
1292994	2300-0228	14,50	14,50	114,0	169,0
1254677	—	14,60	14,60	114,0	169,0
1220018	—	14,70	14,70	114,0	169,0
1179299	2300-0336	14,75	14,75	114,0	169,0
1179300	2300-0230	15,00	15,00	114,0	169,0
1220019	—	15,20	15,20	120,0	178,0
1167860	2300-0231	15,25	15,25	120,0	178,0
1335514	2300-0233	15,50	15,50	120,0	178,0
1175978	2300-0337	15,75	15,75	120,0	178,0
1175977	2300-0234	16,00	16,00	120,0	178,0
1220020	—	16,20	16,20	125,0	184,0
1179301	2300-0235	16,25	16,25	125,0	184,0
1220021	—	16,40	16,40	125,0	184,0
1179302	2300-0236	16,50	16,50	125,0	184,0
1179303	2300-0338	16,75	16,75	125,0	184,0
1177753	2300-0237	17,00	17,00	125,0	184,0
1174001	2300-0238	17,25	17,25	130,0	191,0
1179304	2300-0239	17,40	17,40	130,0	191,0
1167900	2300-0240	17,50	17,50	130,0	191,0
1174002	2300-0339	17,75	17,75	130,0	191,0
1220022	—	17,90	17,90	130,0	195,0
1177754	2300-0241	18,00	18,00	130,0	191,0
1167908	2300-0242	18,25	18,25	135,0	198,0
1179305	2300-0243	18,50	18,50	135,0	198,0
1177755	2300-0244	18,75	18,75	135,0	198,0
1177756	2300-0245	19,00	19,00	135,0	198,0
1167919	2300-0246	19,25	19,25	140,0	205,0
1179306	2300-0247	19,40	19,40	140,0	205,0
1220023	—	19,70	19,70	140,0	205,0
1167928	2300-0340	19,75	19,75	140,0	205,0
1177757	2300-0249	20,00	20,00	140,0	205,0

Свёрла спиральные с цилиндрическим хвостовиком. Средняя серия. Правые

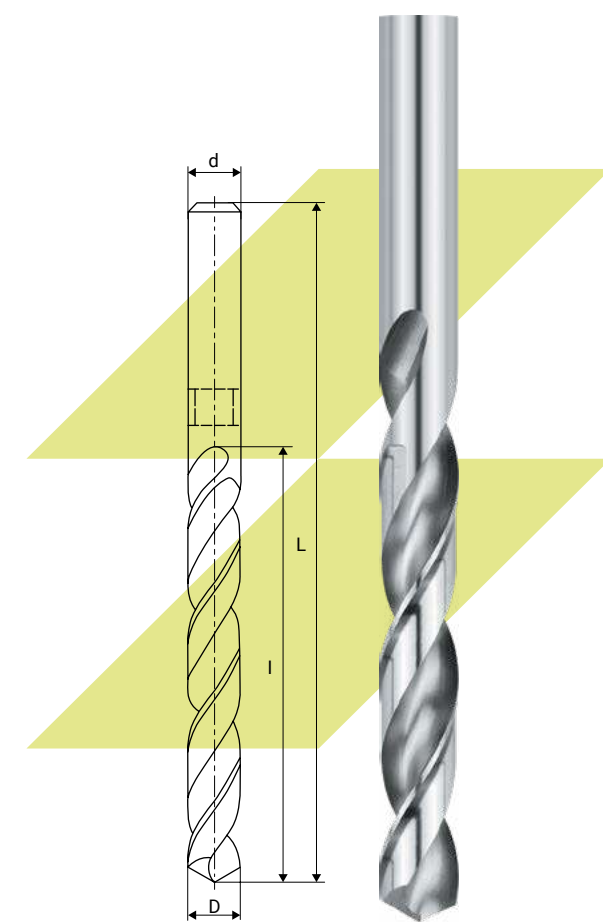
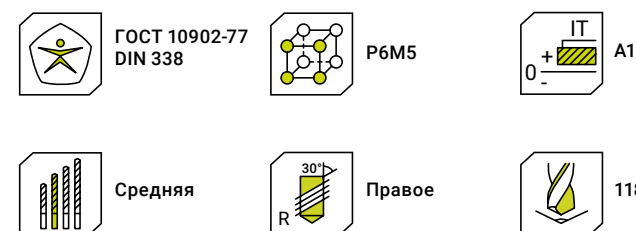
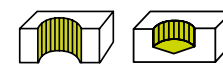

Артикул	Обозначение по ГОСТ	D, мм	d, мм	l, мм	L, мм
1323584	—	0,24	0,24	3,0	19,0
1167203	2300-8169	0,25	0,25	3,0	19,0
1167212	2300-8001	0,30	0,30	3,0	19,0
1167208	—	0,31	0,31	4,0	19,0
1292781	2300-5038	0,32	0,32	4,0	19,0
1167209	—	0,34	0,34	4,0	19,0
1167210	2300-8005	0,35	0,35	4,0	19,0
1292782	2300-8007	0,38	0,38	4,0	19,0
1167214	2300-8011	0,40	0,40	5,0	20,0
1292783	2300-8013	0,42	0,42	5,0	20,0
1292784	—	0,43	0,43	5,0	20,0
1292785	—	0,44	0,44	5,0	20,0
1167217	2300-8012	0,45	0,45	5,0	20,0
1292788	2300-8017	0,48	0,48	5,0	20,0
1292789	2300-8021	0,50	0,50	6,0	22,0
1292792	2300-8025	0,55	0,55	7,0	24,0
1292794	2300-8031	0,60	0,60	7,0	24,0
1292796	2300-8035	0,65	0,65	8,0	26,0
1292797	2300-8037	0,68	0,68	9,0	28,0
1292798	2300-8041	0,70	0,70	9,0	28,0
1292799	2300-8043	0,72	0,72	9,0	28,0
1292800	2300-8045	0,75	0,75	9,0	28,0
1292802	2300-8047	0,78	0,78	10,0	30,0
1292803	2300-8051	0,80	0,80	10,0	30,0
1292804	2300-8053	0,82	0,82	10,0	30,0
1292805	2300-8055	0,85	0,85	10,0	30,0
1292806	2300-8057	0,88	0,88	11,0	32,0
1292807	2300-8061	0,90	0,90	11,0	32,0
1292810	2300-8067	0,98	0,98	12,0	34,0
1292811	2300-8071	1,00	1,00	12,0	34,0
1292812	2300-8073	1,05	1,05	12,0	34,0
1292813	2300-8075	1,10	1,10	14,0	36,0
1276300	2300-8077	1,15	1,15	14,0	36,0
1292814	2300-8081	1,20	1,20	16,0	38,0

Артикул	Обозначение по ГОСТ	D, мм	d, мм	l, мм	L, мм
1292935	2300-6411	15,00	15,00	114,0	169,0
1292936	2300-6412	15,25	15,25	120,0	178,0
1335339	2300-6415	15,40	15,40	120,0	178,0
1292996	2300-6417	15,50	15,50	120,0	178,0
1292937	2300-6421	15,75	15,75	120,0	178,0
1292938	2300-6423	16,00	16,00	120,0	178,0
1292940	2300-6425	16,25	16,25	125,0	184,0
1292942	2300-6427	16,50	16,50	125,0	184,0
1292943	2300-6431	16,75	16,75	125,0	184,0
1292944	2300-6433	17,00	17,00	125,0	184,0
1292945	2300-6435	17,25	17,25	130,0	191,0
1292946	2300-6437	17,40	17,40	130,0	191,0

Артикул	Обозначение по ГОСТ	D, мм	d, мм	l, мм	L, мм
1335340	2300-6441	17,50	17,50	130,0	191,0
1292947	2300-6443	17,75	17,75	130,0	191,0
1292949	2300-6445	18,00	18,00	130,0	191,0
1292997	2300-6447	18,25	18,25	135,0	198,0
1292950	2300-6451	18,50	18,50	135,0	198,0
1292951	2300-6453	18,75	18,75	135,0	198,0
1292952	2300-6455	19,00	19,00	135,0	198,0
1292953	2300-6457	19,25	19,25	140,0	205,0
1292954	2300-6461	19,40	19,40	140,0	205,0
1292998	2300-6463	19,50	19,50	140,0	205,0
1292956	2300-6465	19,75	19,75	140,0	205,0
1292957	2300-6467	20,00	20,00	140,0	205,0

Свёрла спиральные с цилиндрическим хвостовиком. Средняя серия. Правые

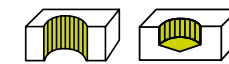

ГОСТ 10902-77
DIN 338

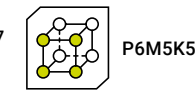

P6M5K5

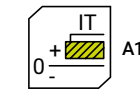

IT A1

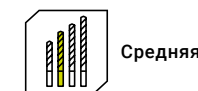

Средняя



Правое



135°

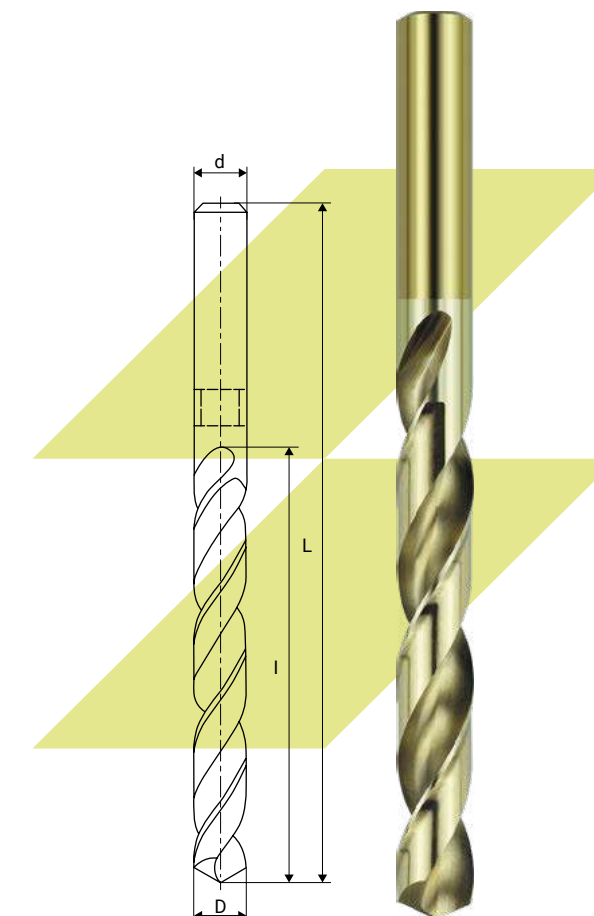

Артикул	Обозначение по ГОСТ	D, мм	d, мм	l, мм	L, мм
1256225	2300-8021	0,50	0,50	6,0	22,0
1256226	2300-8025	0,55	0,55	7,0	24,0
1289566	2300-8027	0,58	0,58	7,0	24,0
1256228	2300-8031	0,60	0,60	7,0	24,0
1293228	2300-8035	0,65	0,65	8,0	26,0
1254673	2300-8041	0,70	0,70	9,0	28,0
1256229	2300-8045	0,75	0,75	9,0	28,0
1254674	2300-8051	0,80	0,80	10,0	30,0
1293229	2300-8055	0,85	0,85	10,0	30,0
1254675	2300-8061	0,90	0,90	11,0	32,0
1265301	2300-8063	0,92	0,92	11,0	32,0
1256230	2300-8065	0,95	0,95	11,0	32,0
1174757	2300-8071	1,00	1,00	12,0	34,0
1174758	2300-8073	1,05	1,05	12,0	34,0
1174759	2300-8075	1,10	1,10	14,0	36,0
1174760	2300-8077	1,15	1,15	14,0	36,0
1174697	2300-8081	1,20	1,20	16,0	38,0
1174698	2300-8083	1,25	1,25	16,0	38,0
1174699	2300-8085	1,30	1,30	16,0	38,0
1174700	2300-8087	1,35	1,35	18,0	40,0
1256231	2300-8091	1,40	1,40	18,0	40,0
1174701	2300-8093	1,45	1,45	18,0	40,0
1174702	2300-8095	1,50	1,50	18,0	40,0
1174703	2300-8097	1,55	1,55	20,0	43,0
1174704	2300-8101	1,60	1,60	20,0	43,0
1174705	2300-8103	1,65	1,65	20,0	43,0
1174706	2300-8105	1,70	1,70	20,0	43,0
1174707	2300-8107	1,75	1,75	22,0	46,0
1240453	2300-8111	1,80	1,80	22,0	46,0
1174708	2300-8113	1,85	1,85	22,0	46,0
1174709	2300-8115	1,90	1,90	22,0	46,0
1174710	2300-8117	1,95	1,95	24,0	49,0
1174711	2300-8121	2,00	2,00	24,0	49,0
1174712	2300-8123	2,05	2,05	24,0	49,0

Свёрла спиральные с цилиндрическим хвостовиком. Средняя серия. Правые

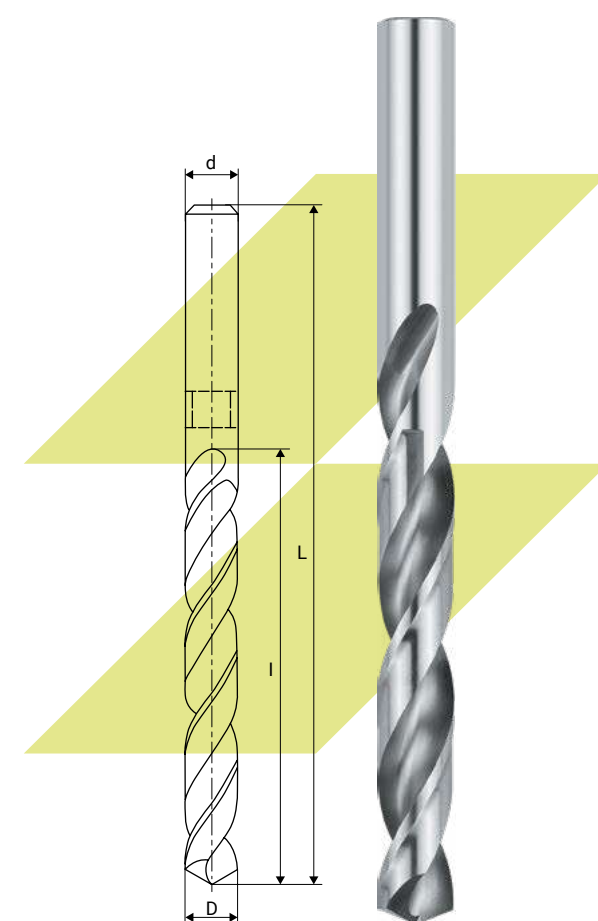
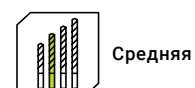
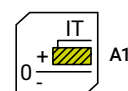

Артикул	Обозначение по ГОСТ	D, мм	d, мм	l, мм	L, мм
1167202	2300-8169	0,25	0,25	3,0	19,0
1167205	2300-8001	0,30	0,30	3,0	19,0
1167213	2300-8011	0,40	0,40	5,0	20,0
1167216	2300-8012	0,45	0,45	5,0	20,0
1323557	2300-8021	0,50	0,50	6,0	22,0
1167224	2300-8025	0,55	0,55	7,0	24,0
1284814	2300-8031	0,60	0,60	7,0	24,0
1167230	2300-8035	0,65	0,65	8,0	26,0
1167233	2300-8041	0,70	0,70	9,0	28,0
1284818	2300-8061	0,90	0,90	11,0	32,0
1330848	2300-8075	1,10	1,10	14,0	36,0
1323599	2300-8077	1,15	1,15	14,0	36,0
1284817	2300-8085	1,30	1,30	16,0	38,0
1331147	2300-8091	1,40	1,40	18,0	40,0
1293294	2300-8097	1,55	1,55	20,0	43,0
1293293	2300-8105	1,70	1,70	20,0	43,0
1167299	2300-0138	1,80	1,80	22,0	46,0
1323569	2300-8115	1,90	1,90	22,0	46,0
1424689	2300-8117	1,95	1,95	24,0	49,0
1331149	2300-8121	2,00	2,00	24,0	49,0
1331150	2300-8123	2,05	2,05	24,0	49,0
1178156	2300-0143	2,10	2,10	24,0	49,0
1273135	2300-0144	2,15	2,15	27,0	53,0
1331151	2300-8133	2,25	2,25	27,0	53,0
1331153	2300-8137	2,35	2,35	27,0	53,0
1326483	2300-8141	2,40	2,40	30,0	57,0
1326484	2300-8151	2,60	2,60	30,0	57,0
1331154	2300-8153	2,65	2,65	30,0	57,0
1331156	2300-8157	2,75	2,75	33,0	61,0
1167358	2300-0153	2,80	2,80	33,0	61,0
1331157	2300-8163	2,85	2,85	33,0	61,0
1331159	2300-8167	2,95	2,95	33,0	61,0
1326253	2300-0155	3,00	3,00	33,0	61,0
1326254	2300-0156	3,10	3,10	36,0	65,0

Артикул	Обозначение по ГОСТ	D, мм	d, мм	l, мм	L, мм
1326255	2300-0157	3,15	3,15	36,0	65,0
1326256	2300-0158	3,20	3,20	36,0	65,0
1326257	2300-0159	3,30	3,30	36,0	65,0
1326258	2300-0160	3,35	3,35	36,0	65,0
1326259	2300-0161	3,40	3,40	39,0	70,0
1326260	2300-0162	3,50	3,50	39,0	70,0
1326261	2300-0163	3,60	3,60	39,0	70,0
1326262	2300-0164	3,70	3,70	39,0	70,0
1326263	2300-0165	3,80	3,80	43,0	75,0
1326264	2300-0166	3,90	3,90	43,0	75,0
1326265	2300-0167	4,00	4,00	43,0	75,0
1326266	2300-0168	4,10	4,10	43,0	75,0
1326267	2300-0169	4,20	4,20	43,0	75,0
1326268	2300-0170	4,25	4,25	43,0	75,0
1326269	2300-0300	4,30	4,30	47,0	80,0
1326270	2300-0301	4,40	4,40	47,0	80,0
1326271	2300-0171	4,50	4,50	47,0	80,0
1326272	2300-0172	4,60	4,60	47,0	80,0
1326273	2300-0302	4,70	4,70	47,0	80,0
1326274	2300-0173	4,80	4,80	52,0	86,0
1326275	2300-0303	4,90	4,90	52,0	86,0
1326276	2300-0174	5,00	5,00	52,0	86,0
1326277	2300-0175	5,10	5,10	52,0	86,0
1326278	2300-0176	5,20	5,20	52,0	86,0
1326279	2300-0304	5,30	5,30	52,0	86,0
1326280	2300-0305	5,40	5,40	57,0	93,0
1326281	2300-0177	5,50	5,50	57,0	93,0
1326282	2300-0178	5,60	5,60	57,0	93,0
1326283	2300-0179	5,70	5,70	57,0	93,0
1326284	2300-0180	5,80	5,80	57,0	93,0
1326285	2300-0306	5,90	5,90	57,0	93,0
1326286	2300-3401	6,00	6,00	57,0	93,0
1326287	2300-3403	6,10	6,10	63,0	101,0
1326288	2300-3405	6,20	6,20	63,0	101,0
1326289	2300-3407	6,30	6,30	63,0	101,0
1326290	2300-3409	6,40	6,40	63,0	101,0
1326291	2300-3411	6,50	6,50	63,0	101,0
1326292	2300-3413	6,60	6,60	63,0	101,0
1326293	2300-3415	6,70	6,70	63,0	101,0

Артикул	Обозначение по ГОСТ	D, мм	d, мм	l, мм	L, мм
1326294	2300-3417	6,80	6,80	69,0	109,0
1326295	2300-3419	6,90	6,90	69,0	109,0
1326296	2300-3421	7,00	7,00	69,0	109,0
1326297	2300-3423	7,10	7,10	69,0	109,0
1326298	2300-3425	7,20	7,20	69,0	109,0
1326299	2300-3427	7,30	7,30	69,0	109,0
1326300	2300-6233	7,40	7,40	69,0	109,0
1326301	2300-3429	7,50	7,50	69,0	109,0
1326302	2300-3431	7,60	7,60	75,0	117,0
1326303	2300-3433	7,70	7,70	75,0	117,0
1326304	2300-3435	7,80	7,80	75,0	117,0
1326305	2300-3437	7,90	7,90	75,0	117,0
1326306	2300-3439	8,00	8,00	75,0	117,0
1326307	2300-3441	8,10	8,10	75,0	117,0
1326308	2300-3443	8,20	8,20	75,0	117,0
1326309	2300-3445	8,30	8,30	75,0	117,0
1326310	2300-3447	8,40	8,40	75,0	117,0
1326311	2300-3449	8,50	8,50	75,0	117,0
1326312	2300-3451	8,60	8,60	81,0	125,0
1326313	2300-3453	8,70	8,70	81,0	125,0
1326314	2300-3455	8,80	8,80	81,0	125,0
1326315	2300-3457	8,90	8,90	81,0	125,0
1326316	2300-3459	9,00	9,00	81,0	125,0
1326317	2300-3461	9,10	9,10	81,0	125,0
1326318	2300-3463	9,20	9,20	81,0	125,0
1326319	2300-3465	9,30	9,30	81,0	125,0
1326320	2300-3467	9,40	9,40	81,0	125,0
1326321	2300-3469	9,50	9,50	81,0	125,0
1326322	2300-3471	9,60	9,60	87,0	133,0
1326323	2300-3473	9,70	9,70	87,0	133,0
1326324	2300-3475	9,80	9,80	87,0	133,0
1326325	2300-3477	9,90	9,90	87,0	133,0
1326326	2300-3479	10,00	10,00	87,0	133,0
1326327	2300-3481	10,10	10,10	87,0	133,0
1326328	2300-3483	10,20	10,20	87,0	133,0
1326329	2300-3485	10,30	10,30	87,0	133,0
1326330	2300-3487	10,40	10,40	87,0	133,0
1326331	2300-3489	10,50	10,50	87,0	133,0
1326332	2300-3491	10,60	10,60	87,0	133,0

Артикул	Обозначение по ГОСТ	D, мм	d, мм	I, мм	L, мм
1326333	2300-3493	10,70	10,70	94,0	142,0
1326334	2300-3495	10,80	10,80	94,0	142,0
1326335	2300-3497	10,90	10,90	94,0	142,0
1326336	2300-3499	11,00	11,00	94,0	142,0
1326337	2300-3501	11,10	11,10	94,0	142,0
1326338	2300-3503	11,20	11,20	94,0	142,0
1326339	2300-3505	11,30	11,30	94,0	142,0
1326340	2300-3507	11,40	11,40	94,0	142,0
1326341	2300-3509	11,50	11,50	94,0	142,0
1326342	2300-6337	11,60	11,60	94,0	142,0
1326343	2300-3511	11,70	11,70	94,0	142,0
1326344	2300-3513	11,80	11,80	94,0	142,0
1326345	2300-3515	11,90	11,90	101,0	151,0
1326346	2300-3517	12,00	12,00	101,0	151,0
1326347	2300-6351	12,10	12,10	101,0	151,0
1326348	2300-6353	12,20	12,20	101,0	151,0
1326349	2300-6355	12,30	12,30	101,0	151,0
1326350	2300-6357	12,40	12,40	101,0	151,0
1326351	2300-6361	12,50	12,50	101,0	151,0
1326352	2300-6363	12,60	12,60	101,0	151,0
1326353	2300-6365	12,70	12,70	101,0	151,0
1326354	2300-6367	12,80	12,80	101,0	151,0
1326355	2300-6371	12,90	12,90	101,0	151,0
1326356	2300-6373	13,00	13,00	101,0	151,0
1326357	2300-6375	13,10	13,10	101,0	151,0
1326358	2300-6377	13,20	13,20	101,0	151,0
1326359	2300-6381	13,30	13,30	108,0	160,0
1326360	2300-6383	13,40	13,40	108,0	160,0
1326361	2300-6385	13,50	13,50	108,0	160,0
1326362	2300-6387	13,60	13,60	108,0	160,0
1326364	2300-6391	13,70	13,70	108,0	160,0
1326363	2300-6393	13,75	13,75	108,0	160,0

Артикул	Обозначение по ГОСТ	D, мм	d, мм	I, мм	L, мм
1326365	2300-6395	13,80	13,80	108,0	160,0
1326366	2300-6397	13,90	13,90	108,0	160,0
1326367	2300-6401	14,00	14,00	108,0	160,0
1326369	—	14,20	14,20	114,0	169,0
1326368	2300-6403	14,25	14,25	114,0	169,0
1326370	—	14,30	14,30	114,0	169,0
1326371	2300-6405	14,50	14,50	114,0	169,0
1326372	—	14,60	14,60	114,0	169,0
1326373	—	14,70	14,70	114,0	169,0
1326374	2300-6407	14,75	14,75	114,0	169,0
1326375	2300-6411	15,00	15,00	114,0	169,0
1326376	2300-6412	15,25	15,25	120,0	178,0
1326377	2300-6417	15,50	15,50	120,0	178,0
1326378	2300-6421	15,75	15,75	120,0	178,0
1326379	2300-6423	16,00	16,00	120,0	178,0
1326380	2300-6425	16,25	16,25	125,0	184,0
1326381	2300-6427	16,50	16,50	125,0	184,0
1326382	2300-6431	16,75	16,75	125,0	184,0
1326383	2300-6433	17,00	17,00	125,0	184,0
1326384	2300-6435	17,25	17,25	130,0	191,0
1326385	2300-6437	17,40	17,40	130,0	191,0
1326386	2300-6443	17,75	17,75	130,0	191,0
1326387	2300-6445	18,00	18,00	130,0	191,0
1326388	2300-6447	18,25	18,25	135,0	198,0
1326389	2300-6451	18,50	18,50	135,0	198,0
1326390	2300-6453	18,75	18,75	135,0	198,0
1326391	2300-6455	19,00	19,00	135,0	198,0
1326392	2300-6457	19,25	19,25	140,0	205,0
1326393	2300-6461	19,40	19,40	140,0	205,0
1326394	2300-6463	19,50	19,50	140,0	205,0
1326395	2300-6465	19,75	19,75	140,0	205,0
1326396	2300-6467	20,00	20,00	140,0	205,0

Свёрла спиральные с цилиндрическим хвостовиком. Средняя серия. Правые

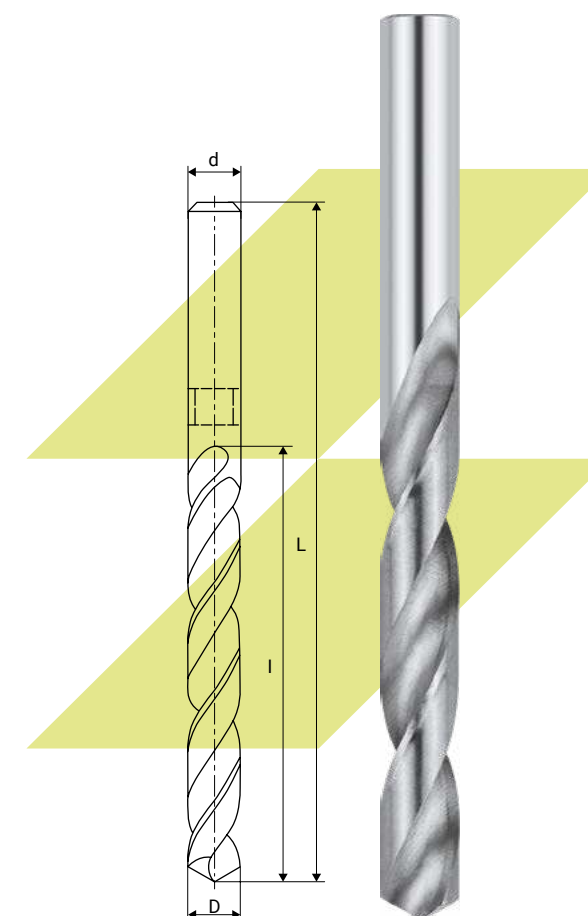
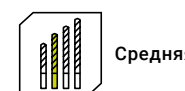
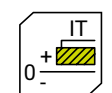
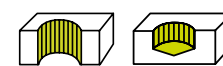

Артикул	Обозначение по ГОСТ	D, мм	d, мм	I, мм	L, мм
1336050	2300-8005	0,35	0,35	3	19
1336051	2300-8011	0,40	0,40	5	20
1336053	2300-8021	0,50	0,50	6	22
1336054	2300-8025	0,55	0,55	7	24
1336055	2300-8031	0,60	0,60	7	24
1336056	2300-8035	0,65	0,65	8	26
1336057	2300-8041	0,70	0,70	9	28
1336058	2300-8045	0,75	0,75	9	28
1336059	2300-8051	0,80	0,80	10	30
1336060	2300-8055	0,85	0,85	10	30
1336061	2300-8061	0,90	0,90	11	32
1336062	2300-8065	0,95	0,95	11	32
1336063	2300-8071	1,00	1,00	12	34
1336064	2300-8073	1,05	1,05	12	34
1336065	2300-8075	1,10	1,10	14	36
1336066	2300-8077	1,15	1,15	14	36
1336067	2300-8081	1,20	1,20	16	38
1336068	2300-8083	1,25	1,25	16	38
1336069	2300-8085	1,30	1,30	16	38
1336070	2300-8087	1,35	1,35	18	40
1336071	2300-8091	1,40	1,40	18	40
1336072	2300-8093	1,45	1,45	18	40
1336073	2300-8095	1,50	1,50	18	40
1336074	2300-8097	1,55	1,55	20	43
1336075	2300-8101	1,60	1,60	20	43
1336076	2300-8103	1,65	1,65	20	43
1336077	2300-8105	1,70	1,70	20	43
1336078	2300-8107	1,75	1,75	22	46
1336079	2300-8111	1,80	1,80	22	46
1336080	2300-8115	1,90	1,90	22	46
1336081	2300-8117	1,95	1,95	24	49
1336082	2300-8121	2,00	2,00	24	49
1336083	2300-8123	2,05	2,05	24	49
1336084	2300-8125	2,10	2,10	24	49

Артикул	Обозначение по ГОСТ	D, мм	d, мм	l, мм	L, мм
1336241	2300-6453	18,75	18,75	135	198
1336242	2300-6455	19,00	19,00	135	198
1336243	2300-6457	19,25	19,25	140	205
1336244	2300-6461	19,40	19,40	140	205
1336245	2300-6463	19,50	19,50	140	205
1336246	2300-6465	19,75	19,75	140	205
1336247	2300-6467	20,00	20,00	140	205

Свёрла спиральные с цилиндрическим хвостовиком. Средняя серия. Левые

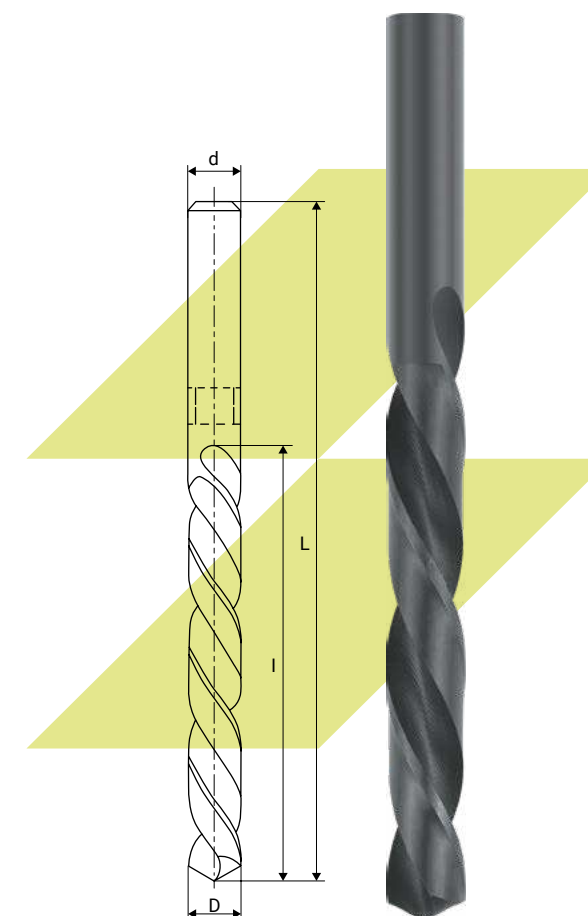
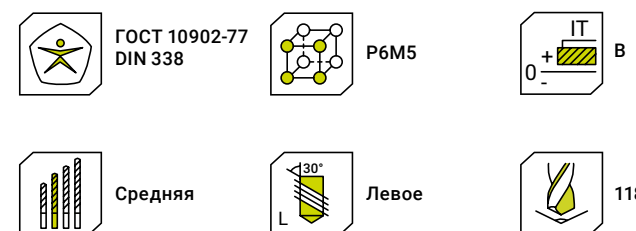
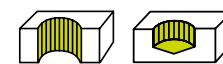

Артикул	Обозначение по ГОСТ	D, мм	d, мм	l, мм	L, мм
1228677	—	0,70	0,70	9,0	28,0
1418650	2300-0542	1,00	1,00	12,0	34,0
1168361	2300-0401	1,10	1,10	14,0	36,0
1261738	2300-0544	1,15	1,15	14,0	36,0
1168363	2300-0402	1,20	1,20	16,0	38,0
1252668	2300-0403	1,25	1,25	16,0	38,0
1168366	2300-0404	1,30	1,30	16,0	38,0
1168367	2300-0405	1,35	1,35	18,0	40,0
1168368	2300-0406	1,40	1,40	18,0	40,0
1168370	2300-0408	1,50	1,50	18,0	40,0
1252669	2300-0545	1,55	1,55	20,0	43,0
1228678	2300-0409	1,60	1,60	20,0	43,0
1228679	2300-0546	1,65	1,65	20,0	43,0
1168374	2300-0410	1,70	1,70	20,0	43,0
1335517	2300-0411	1,75	1,75	22,0	46,0
1168376	2300-0412	1,80	1,80	22,0	46,0
1168377	2300-0547	1,85	1,85	22,0	46,0
1168378	2300-0413	1,90	1,90	22,0	46,0
1168379	2300-0415	2,00	2,00	24,0	49,0
1228680	2300-0416	2,05	2,05	24,0	49,0
1168383	2300-0418	2,15	2,15	27,0	53,0
1177601	2300-0419	2,20	2,20	27,0	53,0
1168389	2300-0420	2,30	2,30	27,0	53,0
1425151	2300-0549	2,35	2,35	27,0	53,0
1168391	2300-0421	2,40	2,40	30,0	57,0
1168392	2300-0550	2,45	2,45	30,0	57,0
1335518	2300-0422	2,50	2,50	30,0	57,0
1258939	2300-0423	2,55	2,55	30,0	57,0
1284669	2300-8152	2,60	2,60	30,0	57,0
1168397	2300-0426	2,70	2,70	33,0	61,0
1168399	2300-0551	2,75	2,75	33,0	61,0
1168401	2300-0427	2,80	2,80	33,0	61,0
1479842	2300-0553	2,95	2,95	33,0	61,0
1228681	2300-7515	3,00	3,00	33,0	61,0

Артикул	Обозначение по ГОСТ	D, мм	d, мм	l, мм	L, мм
1335519	2300-0430	3,10	3,10	36,0	65,0
1168414	2300-0431	3,15	3,15	36,0	65,0
1276584	2300-7524	3,20	3,20	36,0	65,0
1261573	2300-0433	3,30	3,30	36,0	65,0
1261574	2300-0434	3,35	3,35	36,0	65,0
1168422	2300-0435	3,40	3,40	39,0	70,0
1335520	2300-0436	3,50	3,50	39,0	70,0
1168431	2300-7538	3,70	3,70	39,0	70,0
1168432	2300-7542	3,80	3,80	43,0	75,0
1168434	2300-7544	3,90	3,90	43,0	75,0
1335522	2300-7546	4,00	4,00	43,0	75,0
1168440	2300-7548	4,10	4,10	43,0	75,0
1228682	2300-7552	4,20	4,20	43,0	75,0
1326446	2300-7554	4,25	4,25	43,0	75,0
1479843	2300-7556	4,30	4,30	47,0	80,0
1284410	2300-0555	4,40	4,40	47,0	80,0
1284427	2300-0445	4,50	4,50	47,0	80,0
1168452	2300-7564	4,60	4,60	47,0	80,0
1168454	2300-7566	4,70	4,70	47,0	80,0
1168456	2300-7568	4,80	4,80	52,0	86,0
1168458	2300-7572	4,90	4,90	52,0	86,0
1425152	2300-6174	5,00	5,00	52,0	86,0
1168463	2300-6176	5,10	5,10	52,0	86,0
1479844	2300-6178	5,20	5,20	52,0	86,0
1479845	2300-6182	5,30	5,30	52,0	86,0
1479846	2300-6184	5,40	5,40	57,0	93,0
1168471	2300-6184	5,50	5,50	57,0	93,0
1168474	2300-6188	5,60	5,60	57,0	93,0
1168478	2300-6192	5,70	5,70	57,0	93,0
1168483	2300-6196	5,90	5,90	57,0	93,0
1335523	2300-0455	6,00	6,00	57,0	93,0
1168489	2300-0457	6,20	6,20	63,0	101,0
1252670	2300-0458	6,30	6,30	63,0	101,0
1168495	2300-0561	6,40	6,40	63,0	101,0
1228683	2300-0562	6,60	6,60	63,0	101,0
1335524	2300-0563	6,80	6,80	69,0	109,0
1168505	2300-0564	6,90	6,90	69,0	109,0
1425153	2300-0461	7,00	7,00	69,0	109,0
1168513	2300-0463	7,20	7,20	69,0	109,0

Артикул	Обозначение по ГОСТ	D, мм	d, мм	l, мм	L, мм
1168516	2300-0464	7,30	7,30	69,0	109,0
1168519	2300-0465	7,50	7,50	69,0	109,0
1425154	2300-0466	7,60	7,60	75,0	117,0
1168523	2300-0467	7,70	7,70	75,0	117,0
1168525	2300-0468	7,80	7,80	75,0	117,0
1335525	2300-0469	8,00	8,00	75,0	117,0
1168534	2300-0470	8,10	8,10	75,0	117,0
1479847	2300-0471	8,20	8,20	75,0	117,0
1168541	2300-0472	8,30	8,30	75,0	117,0
1168543	2300-0473	8,40	8,40	75,0	117,0
1479848	2300-0474	8,50	8,50	75,0	117,0
1479849	2300-0566	8,60	8,60	81,0	125,0
1168551	2300-0475	8,70	8,70	81,0	125,0
1168554	2300-0567	8,80	8,80	81,0	125,0
1168557	2300-0476	8,90	8,90	81,0	125,0
1479850	2300-0477	9,00	9,00	81,0	125,0
1228685	2300-0568	9,10	9,10	81,0	125,0
1168565	2300-0478	9,20	9,20	81,0	125,0
1168569	2300-0569	9,30	9,30	81,0	125,0
1168571	2300-0570	9,40	9,40	81,0	125,0
1425155	2300-0479	9,50	9,50	81,0	125,0
1168582	2300-0481	9,70	9,70	87,0	133,0
1168584	2300-0571	9,80	9,80	87,0	133,0
1228686	2300-0482	10,00	10,00	87,0	133,0
1228688	2300-0483	10,10	10,10	87,0	133,0
1168594	2300-0484	10,20	10,20	87,0	133,0
1228691	2300-0573	10,30	10,30	87,0	133,0
1479896	2300-0486	10,50	10,50	87,0	133,0
1425156	2300-0574	10,60	10,60	87,0	133,0
1425157	2300-0487	10,70	10,70	94,0	142,0
1168604	2300-0575	10,80	10,80	94,0	142,0
1345868	2300-6328	11,20	11,20	94,0	142,0
1425158	2300-0579	11,40	11,40	94,0	142,0
1168609	2300-0490	11,50	11,50	94,0	142,0
1168610	2300-0491	11,70	11,70	94,0	142,0
1425159	2300-0493	12,00	12,00	101,0	151,0
1335526	2300-0494	12,50	12,50	101,0	151,0
1425160	2300-0496	13,00	13,00	101,0	151,0
1168624	2300-0498	13,50	13,50	108,0	160,0

Артикул	Обозначение по ГОСТ	D, мм	d, мм	l, мм	L, мм
1376530	2300-0499	13,70	13,70	108,0	160,0
1479851	2300-0500	14,00	14,00	108,0	160,0
1252665	2300-0502	14,50	14,50	114,0	169,0
1168634	—	14,70	14,70	114,0	169,0
1168635	2300-0504	15,00	15,00	114,0	169,0
1168638	2300-0591	15,75	15,75	120,0	178,0
1168640	2300-0508	16,00	16,00	120,0	178,0

Артикул	Обозначение по ГОСТ	D, мм	d, мм	l, мм	L, мм
1168642	2300-0510	16,50	16,50	125,0	184,0
1425161	2300-0511	17,00	17,00	125,0	184,0
1168645	2300-0514	17,50	17,50	130,0	191,0
1168647	2300-0515	18,00	18,00	130,0	191,0
1168651	2300-0519	19,00	19,00	140,0	205,0
1168654	2300-0523	20,00	20,00	140,0	205,0

Свёрла спиральные с цилиндрическим хвостовиком. Короткая серия. Правые



ГОСТ 4010-77
DIN 1897

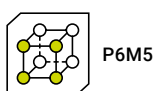

P6M5

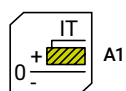

IT
A1



Короткая



Правое



118°

Артикул	Обозначение по ГОСТ	D, мм	d, мм	l, мм	L, мм
1243716	2300-5301	0,50	0,50	3,0	20,0
1243717	2300-5303	0,75	0,75	4,5	23,0
1243718	2300-5305	0,80	0,80	5,0	24,0
1243719	2300-5307	0,85	0,85	5,0	24,0
1243720	2300-5311	0,90	0,90	5,5	25,0
1243721	2300-5313	0,95	0,95	5,5	25,0
1243722	2300-5315	1,00	1,00	6,0	26,0
1243723	2300-5317	1,05	1,05	6,0	26,0
1243724	2300-5321	1,10	1,10	7,0	28,0
1181258	2300-5323	1,15	1,15	7,0	28,0
1243725	2300-5325	1,20	1,20	8,0	30,0
1243726	2300-5327	1,25	1,25	8,0	30,0
1243727	2300-5331	1,30	1,30	8,0	30,0
1243728	2300-5333	1,35	1,35	9,0	32,0
1243729	2300-5335	1,40	1,40	9,0	32,0
1243730	2300-5337	1,45	1,45	9,0	32,0
1243731	2300-5341	1,50	1,50	9,0	32,0
1243732	2300-5343	1,55	1,55	10,0	34,0
1243733	2300-5345	1,60	1,60	10,0	34,0
1243734	2300-5347	1,65	1,65	10,0	34,0
1243735	2300-5351	1,70	1,70	10,0	34,0
1243737	2300-5355	1,80	1,80	11,0	36,0
1243738	2300-5355	1,85	1,85	11,0	36,0
1243739	2300-5361	1,90	1,90	11,0	36,0
1243740	2300-5363	1,95	1,95	12,0	38,0
1243741	2300-5365	2,00	2,00	12,0	38,0
1243742	2300-5367	2,05	2,05	12,0	38,0
1243743	2300-5371	2,10	2,10	12,0	38,0
1243744	2300-5373	2,15	2,15	13,0	40,0
1243745	2300-5375	2,20	2,20	13,0	40,0
1243746	2300-5377	2,25	2,25	13,0	40,0
1243747	2300-5381	2,30	2,30	13,0	40,0
1243748	2300-5383	2,35	2,35	13,0	40,0
1243749	2300-5385	2,40	2,40	14,0	43,0

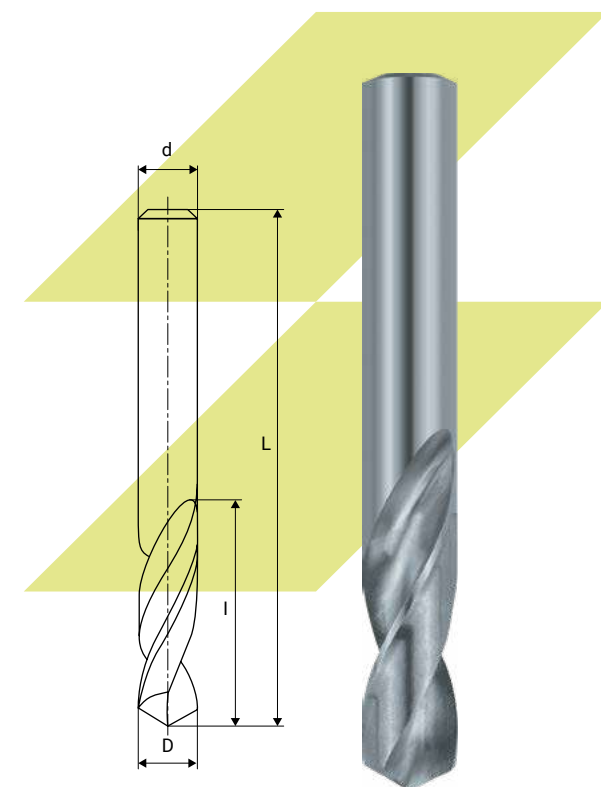

Артикул	Обозначение по ГОСТ	D, мм	d, мм	l, мм	L, мм
1243750	2300-5387	2,45	2,45	14,0	43,0
1243752	2300-5393	2,55	2,55	14,0	43,0
1243753	2300-5395	2,60	2,60	14,0	43,0
1243754	2300-5397	2,65	2,65	14,0	43,0
1243755	2300-5401	2,70	2,70	16,0	46,0
1243756	2300-5403	2,75	2,75	16,0	46,0
1243757	2300-5405	2,80	2,80	16,0	46,0
1243758	2300-5407	2,85	2,85	16,0	46,0
1243759	2300-5411	2,90	2,90	16,0	46,0
1243760	2300-5413	2,95	2,95	16,0	46,0
1243761	2300-5415	3,00	3,00	16,0	46,0
1243762	2300-5417	3,10	3,10	18,0	49,0
1243763	2300-5421	3,15	3,15	18,0	49,0
1243764	2300-5423	3,20	3,20	18,0	49,0
1243765	2300-5425	3,30	3,30	18,0	49,0
1243766	2300-5427	3,35	3,35	18,0	49,0
1243767	2300-5431	3,40	3,40	20,0	52,0
1243768	2300-5433	3,50	3,50	20,0	52,0
1243769	2300-5435	3,60	3,60	20,0	52,0
1243770	2300-5437	3,70	3,70	20,0	52,0
1243771	2300-5441	3,80	3,80	22,0	55,0
1243772	2300-5443	3,90	3,90	22,0	55,0
1243773	2300-5445	4,00	4,00	22,0	55,0
1243774	2300-5447	4,10	4,10	22,0	55,0
1243775	2300-5451	4,20	4,20	22,0	55,0
1243776	2300-5453	4,25	4,25	22,0	55,0
1243777	2300-5455	4,30	4,30	24,0	58,0
1243778	2300-5457	4,40	4,40	24,0	58,0
1243779	2300-5461	4,50	4,50	24,0	58,0
1243780	2300-5463	4,60	4,60	24,0	58,0
1243782	2300-5467	4,80	4,80	26,0	62,0
1243783	2300-5471	4,90	4,90	26,0	62,0
1243784	2300-5473	5,00	5,00	26,0	62,0
1243785	2300-5475	5,10	5,10	26,0	62,0
1243786	2300-5477	5,20	5,20	26,0	62,0
1243787	2300-5481	5,30	5,30	26,0	62,0
1243788	2300-5483	5,40	5,40	28,0	66,0
1243789	2300-5485	5,50	5,50	28,0	66,0
1243790	2300-5487	5,60	5,60	28,0	66,0

Артикул	Обозначение по ГОСТ	D, мм	d, мм	l, мм	L, мм
1243791	2300-5491	5,70	5,70	28,0	66,0
1243792	2300-5493	5,80	5,80	28,0	66,0
1243793	2300-5495	5,90	5,90	28,0	66,0
1243794	2300-5497	6,00	6,00	28,0	66,0
1243795	2300-5501	6,10	6,10	31,0	70,0
1243796	2300-5503	6,20	6,20	31,0	70,0
1243797	2300-5505	6,30	6,30	31,0	70,0
1243798	2300-5507	6,40	6,40	31,0	70,0
1243799	2300-5511	6,50	6,50	31,0	70,0
1243800	2300-5513	6,60	6,60	31,0	70,0
1243801	2300-5515	6,70	6,70	31,0	70,0
1243802	2300-5517	6,80	6,80	34,0	74,0
1243803	2300-5521	6,90	6,90	34,0	74,0
1243804	2300-5523	7,00	7,00	34,0	74,0
1243805	2300-5525	7,10	7,10	34,0	74,0
1243806	2300-5527	7,20	7,20	34,0	74,0
1243807	2300-5531	7,30	7,30	34,0	74,0
1243808	2300-5533	7,40	7,40	34,0	74,0
1243809	2300-5535	7,50	7,50	34,0	74,0
1243810	2300-5537	7,60	7,60	37,0	79,0
1243811	2300-5541	7,70	7,70	37,0	79,0
1243812	2300-5543	7,80	7,80	37,0	79,0
1243813	2300-5545	7,90	7,90	37,0	79,0
1243814	2300-5547	8,00	8,00	37,0	79,0
1243815	2300-5551	8,10	8,10	37,0	79,0
1243816	2300-5553	8,20	8,20	37,0	79,0
1243817	2300-5555	8,30	8,30	37,0	79,0
1243818	2300-5557	8,40	8,40	37,0	79,0
1243819	2300-5561	8,50	8,50	37,0	79,0
1243820	2300-5563	8,60	8,60	40,0	84,0
1243821	2300-5565	8,70	8,70	40,0	84,0
1243822	2300-5567	8,80	8,80	40,0	84,0
1243823	2300-5571	8,90	8,90	40,0	84,0
1243824	2300-5573	9,00	9,00	40,0	84,0
1243825	2300-5575	9,10	9,10	40,0	84,0
1243826	2300-5577	9,20	9,20	40,0	84,0
1243827	2300-5581	9,30	9,30	40,0	84,0
1243828	2300-5583	9,40	9,40	40,0	84,0
1243829	2300-5585	9,50	9,50	40,0	84,0

Артикул	Обозначение по ГОСТ	D, мм	d, мм	l, мм	L, мм
1243830	2300-5587	9,60	9,60	43,0	89,0
1243831	2300-5591	9,70	9,70	43,0	89,0
1243832	2300-5593	9,80	9,80	43,0	89,0
1243833	2300-5595	9,90	9,90	43,0	89,0
1243834	2300-5597	10,00	10,00	43,0	89,0
1243835	2300-5601	10,10	10,10	43,0	89,0
1243836	2300-5603	10,20	10,20	43,0	89,0
1243837	2300-5605	10,30	10,30	43,0	89,0
1243838	2300-5607	10,40	10,40	43,0	89,0
1243839	2300-5611	10,50	10,50	43,0	89,0
1243840	2300-5613	10,60	10,60	43,0	89,0
1243842	2300-5617	10,80	10,80	47,0	95,0
1243843	2300-5621	10,90	10,90	47,0	95,0
1243844	2300-5623	11,00	11,00	47,0	95,0
1243845	2300-5625	11,10	11,10	47,0	95,0
1243846	2300-5627	11,20	11,20	47,0	95,0
1243847	2300-5631	11,30	11,30	47,0	95,0
1243848	2300-5633	11,40	11,40	47,0	95,0
1243849	2300-5635	11,50	11,50	47,0	95,0
1243850	2300-5637	11,70	11,70	47,0	95,0
1243851	2300-5641	11,80	11,80	47,0	95,0
1243852	2300-5643	11,90	11,90	51,0	102,0
1243853	2300-5645	12,00	12,00	51,0	102,0
1243854	2300-5647	12,10	12,10	51,0	102,0
1243855	2300-5651	12,20	12,20	51,0	102,0
1243856	2300-5653	12,30	12,30	51,0	102,0
1243857	2300-5655	12,40	12,40	51,0	102,0
1243858	2300-5657	12,50	12,50	51,0	102,0
1243859	2300-5661	12,60	12,60	51,0	102,0
1243860	2300-5663	12,70	12,70	51,0	102,0
1243861	2300-5665	12,80	12,80	51,0	102,0
1243862	2300-5667	13,00	13,00	51,0	102,0
1243863	2300-5671	13,10	13,10	51,0	102,0
1243865	2300-5675	13,30	13,30	54,0	107,0

Артикул	Обозначение по ГОСТ	D, мм	d, мм	l, мм	L, мм
1243866	2300-5677	13,50	13,50	54,0	107,0
1243867	2300-5681	13,70	13,70	54,0	107,0
1243868	2300-5683	13,75	13,75	54,0	107,0
1243869	2300-5685	13,80	13,80	54,0	107,0
1243870	2300-5687	13,90	13,90	54,0	107,0
1343251	2300-5691	14,00	14,00	54,0	107,0
1243872	2300-5693	14,25	14,25	56,0	111,0
1243873	2300-5695	14,50	14,50	56,0	111,0
1243874	2300-5697	14,75	14,75	56,0	111,0
1243875	2300-5701	15,00	15,00	56,0	111,0
1243876	2300-5703	15,25	15,25	58,0	115,0
1243877	2300-5705	15,40	15,40	58,0	115,0
1243878	2300-5707	15,50	15,50	58,0	115,0
1243879	2300-5711	15,75	15,75	58,0	115,0
1243880	2300-5713	16,00	16,00	58,0	115,0
1243881	2300-5715	16,25	16,25	60,0	119,0
1243882	2300-5717	16,50	16,50	60,0	119,0
1243883	2300-5721	16,75	16,75	60,0	119,0
1243884	2300-5723	17,00	17,00	60,0	119,0
1243885	2300-5725	17,25	17,25	62,0	123,0
1243886	2300-5727	17,40	17,40	62,0	123,0
1243887	2300-5731	17,50	17,50	62,0	123,0
1243888	2300-5733	17,75	17,75	62,0	123,0
1243889	2300-5735	18,00	18,00	62,0	123,0
1243890	2300-5737	18,25	18,25	64,0	127,0
1243891	2300-5741	18,50	18,50	64,0	127,0
1243892	2300-5743	18,75	18,75	64,0	127,0
1243893	2300-5745	19,00	19,00	64,0	127,0
1243894	2300-5747	19,25	19,25	66,0	131,0
1243895	2300-5751	19,40	19,40	66,0	131,0
1243896	2300-5753	19,50	19,50	66,0	131,0
1243898	2300-5757	20,00	20,00	66,0	131,0
1479841	2300-9295	22,00	22,00	70,0	141,0

Свёрла спиральные с цилиндрическим хвостовиком. Короткая серия. Левые

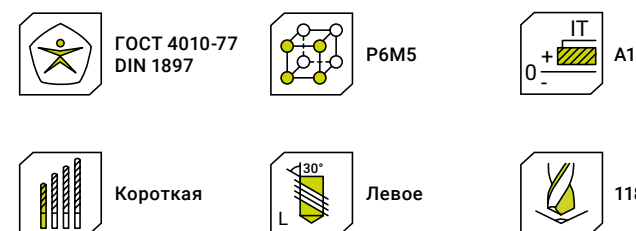
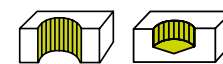

Артикул	Обозначение по ГОСТ	D, мм	d, мм	l, мм	L, мм
1284644	2300-5306	0,80	0,80	5,0	24,0
1284645	2300-5008	0,85	0,85	5,0	24,0
1284640	2300-5326	1,80	1,80	11,0	36,0
1284641	2300-5358	1,85	1,85	11,0	36,0
1336011	2300-3023	2,10	2,10	12,0	38,0
1284649	2300-5376	2,20	2,20	13,0	40,0
1425162	2300-3031	2,50	2,50	14,0	43,0
1326069	2300-5394	2,55	2,55	14,0	43,0
1284650	2300-3033	2,60	2,60	14,0	43,0
1425163	2300-3037	2,80	2,80	16,0	49,0
1284648	2300-3039	2,90	2,90	16,0	49,0
1425164	2300-3041	3,00	3,00	16,0	49,0
1276618	2300-3042	3,10	3,10	18,0	49,0
1276619	2300-3043	3,15	3,15	18,0	49,0
1168425	2300-3048	3,50	3,50	20,0	52,0
1168429	2300-3049	3,60	3,60	20,0	52,0
1168435	2300-3052	3,90	3,90	20,0	52,0
1416351	2300-3053	4,00	4,00	22,0	55,0
1168445	2300-3056	4,25	4,25	22,0	55,0
1168449	2300-3058	4,40	4,40	24,0	58,0
1284488	2300-3063	4,90	4,90	26,0	62,0
1425165	2300-3064	5,00	5,00	26,0	62,0
1425166	2300-3066	5,20	5,20	26,0	62,0
1425167	2300-3067	5,30	5,30	26,0	62,0
1425168	2300-3069	5,50	5,50	28,0	66,0
1425169	2300-3070	5,60	5,60	28,0	66,0
1168479	2300-3071	5,70	5,70	28,0	66,0
1425170	2300-3076	6,20	6,20	31,0	70,0
1425171	2300-3077	6,30	6,30	31,0	70,0
1425172	2300-3079	6,50	6,50	31,0	70,0
1168506	2300-3083	6,90	6,90	34,0	74,0
1220051	2300-3084	7,00	7,00	34,0	74,0
1168511	2300-3085	7,10	7,10	34,0	74,0
1168517	2300-3087	7,30	7,30	34,0	74,0

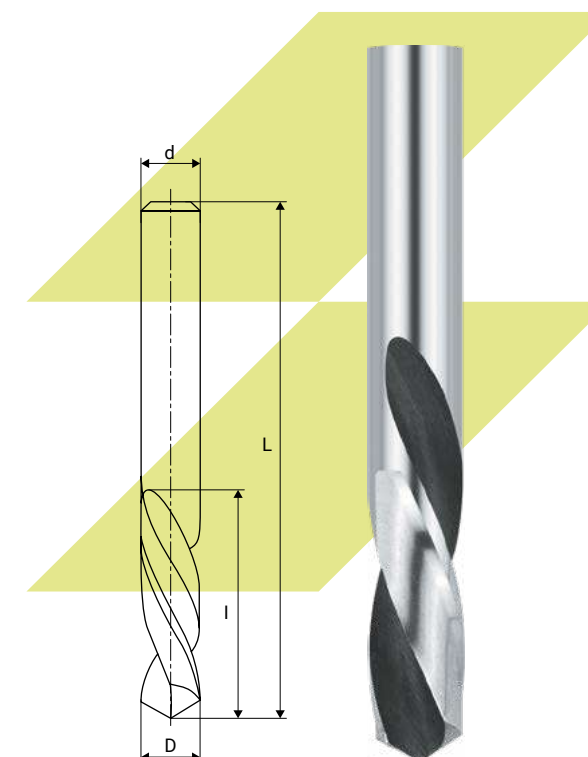

Артикул	Обозначение по ГОСТ	D, мм	d, мм	l, мм	L, мм
1168522	2300-3089	7,60	7,60	37,0	79,0
1168524	2300-3090	7,70	7,70	37,0	79,0
1168526	2300-3091	7,80	7,80	37,0	79,0
1228684	2300-3093	8,00	8,00	37,0	79,0
1425173	2300-3094	8,10	8,10	37,0	79,0
1168539	2300-3095	8,20	8,20	37,0	79,0
1425174	2300-3096	8,30	8,30	37,0	79,0
1168558	2300-3102	8,90	8,90	40,0	84,0
1425175	2300-3103	9,00	9,00	40,0	84,0
1168566	2300-3105	9,20	9,20	40,0	84,0
1168570	2300-3106	9,30	9,30	40,0	84,0
1168572	2300-3107	9,40	9,40	40,0	84,0
1168575	2300-3108	9,50	9,50	40,0	84,0
1425176	2300-3109	9,60	9,60	43,0	89,0
1168583	2300-3110	9,70	9,70	43,0	89,0
1425177	2300-3111	9,80	9,80	43,0	89,0
1228687	2300-3113	10,00	10,00	43,0	89,0

Артикул	Обозначение по ГОСТ	D, мм	d, мм	l, мм	L, мм
1228689	2300-3114	10,10	10,10	43,0	89,0
1228690	2300-3116	10,30	10,30	43,0	89,0
1425178	2300-3117	10,40	10,40	43,0	89,0
1425179	2300-3119	10,60	10,60	43,0	89,0
1168606	2300-3123	11,00	11,00	47,0	95,0
1168607	2300-3125	11,20	11,20	47,0	95,0
1168613	2300-3132	12,00	12,00	51,0	102,0
1168617	2300-3137	12,50	12,50	51,0	102,0
1289719	2300-3141	13,00	13,00	51,0	102,0
1168625	2300-3145	13,50	13,50	54,0	107,0
1252664	2300-3148	14,00	14,00	54,0	107,0
1252666	2300-3150	14,50	14,50	56,0	111,0
1252667	2300-3152	15,00	15,00	56,0	111,0
1168641	2300-3157	16,00	16,00	58,0	115,0
1425180	2300-3161	17,00	17,00	60,0	119,0
1183243	2300-3162	17,25	17,25	62,0	123,0

Свёрла спиральные с цилиндрическим хвостовиком. Короткая серия. Левые

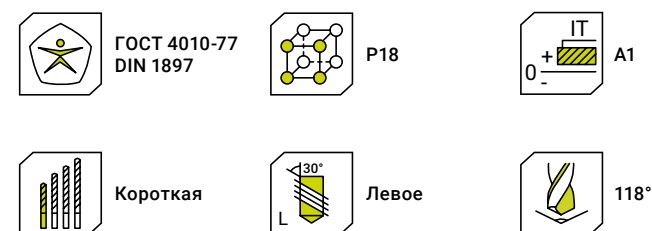

Артикул	Обозначение по ГОСТ	D, мм	d, мм	l, мм	L, мм
1326403	2300-3021	2,0	2,0	12,0	38,0
1276746	2300-3049	3,6	3,6	20,0	52,0
1284429	2300-3059	4,5	4,5	24,0	58,0
1168453	2300-3061	4,7	4,7	24,0	58,0
1168485	2300-3074	6,0	6,0	28,0	66,0
1168494	2300-3078	6,4	6,4	31,0	70,0
1168502	2300-3081	6,7	6,7	31,0	70,0
1168514	2300-3086	7,2	7,2	34,0	74,0
1284788	2300-3087	7,3	7,3	34,0	74,0
1174923	2300-3098	8,5	8,5	37,0	79,0
1174925	2300-3099	8,6	8,6	40,0	84,0
1284867	2300-3100	8,7	8,7	40,0	84,0
1168553	2300-3101	8,8	8,8	40,0	84,0
1168556	2300-3102	8,9	8,9	40,0	84,0
1477175	2300-3104	9,1	9,1	40,0	84,0
1168573	2300-3108	9,5	9,5	40,0	84,0
1168581	2300-3110	9,7	9,7	43,0	89,0
1287092	2300-3118	10,5	10,5	43,0	89,0
1168608	2300-3128	11,5	11,5	47,0	95,0
1253741	2300-3129	11,7	11,7	47,0	95,0
1289407	2300-3137	12,5	12,5	51,0	102,0
1289593	2300-3139	12,7	12,7	51,0	102,0
1168620	2300-3141	13,0	13,0	51,0	102,0
1168631	—	14,2	14,2	56,0	111,0
1379659	2300-3150	14,5	14,5	56,0	111,0
1183240	—	15,7	15,7	58,0	115,0
1168639	2300-3157	16,0	16,0	58,0	115,0
1168644	2300-3164	17,5	17,5	62,0	123,0
1168646	2300-3166	18,0	18,0	62,0	123,0
1168653	2300-3175	20,0	20,0	68,0	136,0

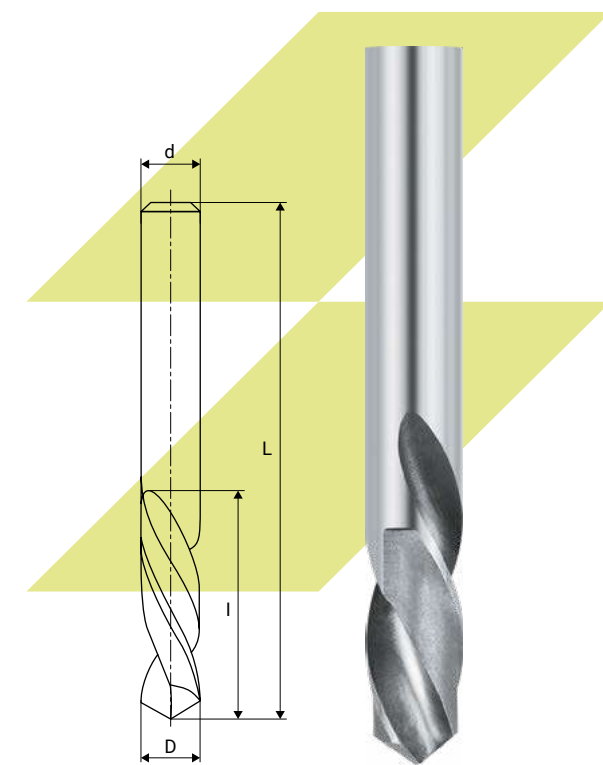

Свёрла спиральные с цилиндрическим хвостовиком. Длинная серия. Правые

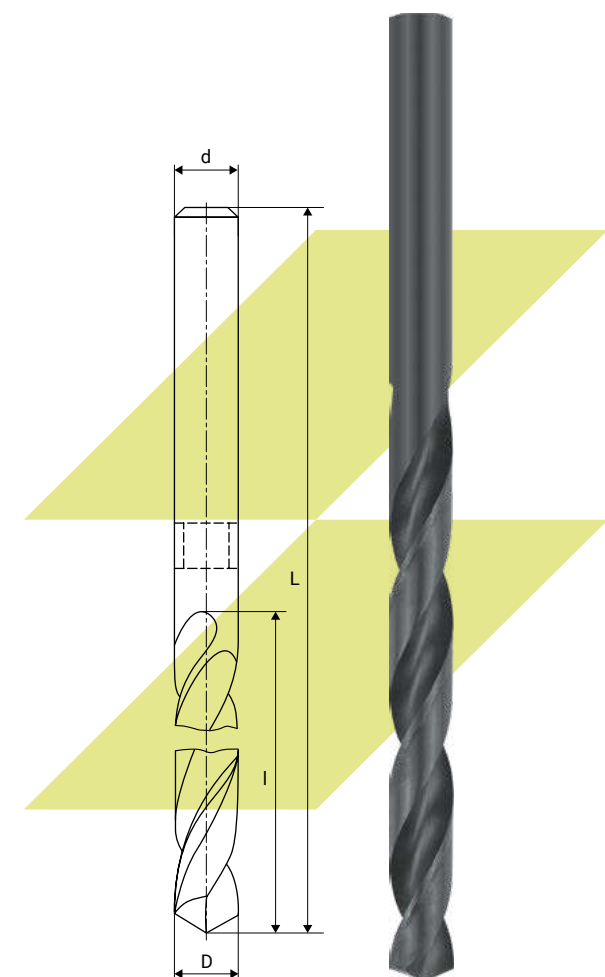
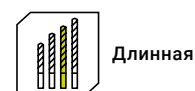
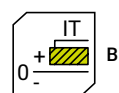
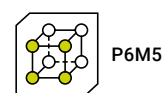
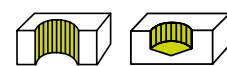

Артикул	Обозначение по ГОСТ	D, мм	d, мм	l, мм	L, мм
1167949	—	1,13	1,13	37,0	60,0
1261565	2300-2151	1,95	1,95	56,0	85,0
1167969	2300-0001	2,00	2,00	56,0	85,0
1257978	2300-0002	2,05	2,05	56,0	85,0
1167975	2300-0003	2,10	2,10	56,0	85,0
1220851	2300-0004	2,15	2,15	59,0	90,0
1179345	2300-0005	2,20	2,20	59,0	90,0
1326032	2300-0007	2,40	2,40	62,0	95,0
1264186	2300-2154	2,45	2,45	62,0	95,0
1167992	2300-0008	2,50	2,50	62,0	95,0
1220024	2300-0009	2,55	2,55	62,0	95,0
1261566	2300-0010	2,60	2,60	62,0	95,0
1167995	2300-0011	2,65	2,65	62,0	95,0
1258092	2300-2155	2,75	2,75	66,0	100,0
1177788	2300-0013	2,80	2,80	66,0	100,0
1168002	2300-2156	2,85	2,85	66,0	100,0
1177789	2300-0014	2,90	2,90	66,0	100,0
1261567	2300-2157	2,95	2,95	66,0	100,0
1168011	2300-0015	3,00	3,00	66,0	100,0
1168017	2300-0016	3,10	3,10	69,0	106,0
1168023	2300-0018	3,20	3,20	69,0	106,0
1168028	2300-0019	3,30	3,30	69,0	106,0
1326033	2300-0020	3,35	3,35	69,0	106,0
1326034	2300-0022	3,50	3,50	73,0	112,0
1168036	2300-0023	3,60	3,60	73,0	112,0
1168040	2300-0024	3,70	3,70	73,0	112,0
1177790	2300-0025	3,80	3,80	78,0	119,0
1177791	2300-0026	3,90	3,90	78,0	119,0
1168053	2300-0027	4,00	4,00	78,0	119,0
1168058	2300-0028	4,10	4,10	78,0	119,0
1168062	2300-0029	4,20	4,20	78,0	119,0
1261568	2300-0030	4,25	4,25	78,0	119,0
1177792	2300-2158	4,30	4,30	82,0	126,0
1168067	2300-2159	4,40	4,40	82,0	126,0

Артикул	Обозначение по ГОСТ	D, мм	d, мм	l, мм	L, мм
1177793	2300-0031	4,50	4,50	82,0	126,0
1168076	2300-0032	4,60	4,60	82,0	126,0
1168078	2300-2160	4,70	4,70	82,0	126,0
1583121	2300-0033	4,80	4,80	87,0	132,0
1174003	2300-2161	4,90	4,90	87,0	132,0
1181259	2300-0034	5,00	5,00	87,0	132,0
1168095	2300-0035	5,10	5,10	87,0	132,0
1168099	2300-6963	5,20	5,20	87,0	132,0
1326035	2300-6964	5,30	5,30	87,0	132,0
1168107	2300-6965	5,40	5,40	91,0	139,0
1168113	2300-6966	5,50	5,50	91,0	139,0
1168118	2300-6967	5,60	5,60	91,0	139,0
1168121	2300-6968	5,70	5,70	91,0	139,0
1168125	2300-6969	5,80	5,80	91,0	139,0
1168129	2300-6971	5,90	5,90	91,0	139,0
1168139	2300-6972	6,00	6,00	91,0	139,0
1168143	2300-6973	6,10	6,10	97,0	148,0
1326036	2300-6974	6,20	6,20	97,0	148,0
1345996	2300-6975	6,30	6,30	97,0	148,0
1168153	2300-6976	6,40	6,40	97,0	148,0
1326037	2300-6977	6,50	6,50	97,0	148,0
1261569	2300-6979	6,70	6,70	97,0	148,0
1177794	2300-6982	6,90	6,90	102,0	156,0
1168179	2300-6983	7,00	7,00	102,0	156,0
1326038	2300-6985	7,20	7,20	102,0	156,0
1168189	2300-6986	7,30	7,30	102,0	156,0
1326039	2300-5242	7,40	7,40	102,0	156,0
1168191	2300-6988	7,50	7,50	102,0	156,0
1168193	2300-6989	7,60	7,60	109,0	165,0
1168195	2300-6991	7,70	7,70	109,0	165,0
1518187	2300-6992	7,80	7,80	109,0	165,0
1179346	2300-6993	7,90	7,90	109,0	165,0
1168204	2300-6994	8,00	8,00	109,0	165,0
1168212	2300-6996	8,25	8,25	109,0	165,0
1168214	2300-6998	8,40	8,40	109,0	165,0
1326040	2300-6999	8,50	8,50	109,0	165,0
1326041	2300-7002	8,70	8,70	115,0	175,0
1326042	2300-7003	8,80	8,80	115,0	175,0
1168227	2300-7005	9,00	9,00	115,0	175,0

Артикул	Обозначение по ГОСТ	D, мм	d, мм	l, мм	L, мм
1168233	2300-7007	9,20	9,20	115,0	175,0
1168234	2300-7008	9,30	9,30	115,0	175,0
1177795	2300-7009	9,40	9,40	115,0	175,0
1168236	2300-7011	9,50	9,50	115,0	175,0
1177796	2300-7012	9,60	9,60	121,0	184,0
1256213	2300-7015	9,90	9,90	121,0	184,0
1326043	2300-7016	10,00	10,00	121,0	184,0
1168245	2300-0069	10,10	10,10	121,0	184,0
1168246	2300-0070	10,20	10,20	121,0	184,0
1168247	2300-2177	10,30	10,30	121,0	184,0
1168248	2300-0071	10,40	10,40	121,0	184,0
1168250	2300-0072	10,50	10,50	121,0	184,0
1326044	2300-2178	10,60	10,60	121,0	184,0
1168252	2300-0073	10,70	10,70	128,0	195,0
1326045	2300-2179	10,80	10,80	128,0	195,0
1326046	2300-2180	10,90	10,90	128,0	195,0
1518188	2300-0074	11,00	11,00	128,0	195,0
1168258	2300-2181	11,10	11,10	128,0	195,0
1168259	2300-0075	11,20	11,20	128,0	195,0
1168260	2300-2182	11,30	11,30	128,0	195,0
1175053	2300-2183	11,40	11,40	128,0	195,0
1168261	2300-0076	11,50	11,50	128,0	195,0
1256214	2300-5244	11,60	11,60	128,0	195,0
1168263	2300-0077	11,70	11,70	128,0	195,0
1168264	2300-2184	11,80	11,80	128,0	195,0
1256215	2300-0078	11,90	11,90	134,0	205,0
1168266	2300-0079	12,00	12,00	134,0	205,0
1256217	2300-2185	12,10	12,10	134,0	205,0
1261570	2300-2186	12,20	12,20	134,0	205,0
1168271	2300-2187	12,30	12,30	134,0	205,0
1256218	2300-2188	12,40	12,40	134,0	205,0
1168272	2300-0080	12,50	12,50	134,0	205,0
1261571	2300-2189	12,60	12,60	134,0	205,0
1326047	2300-0081	12,70	12,70	134,0	205,0
1168275	2300-2190	12,80	12,80	134,0	205,0
1256219	2300-5246	12,90	12,90	134,0	205,0
1168276	2300-0082	13,00	13,00	134,0	205,0
1168277	2300-2191	13,10	13,10	134,0	205,0
1168278	2300-0083	13,20	13,20	134,0	205,0

Артикул	Обозначение по ГОСТ	D, мм	d, мм	l, мм	L, мм
1256220	2300-2192	13,30	13,30	140,0	214,0
1326048	2300-5248	13,40	13,40	140,0	214,0
1168279	2300-0084	13,50	13,50	140,0	214,0
1326049	2300-5251	13,60	13,60	140,0	214,0
1326050	2300-0085	13,70	13,70	140,0	214,0
1326051	2300-5253	13,75	13,75	140,0	214,0
1168280	2300-2193	13,80	13,80	140,0	214,0
1326052	2300-5255	13,90	13,90	140,0	214,0
1326053	2300-0086	14,00	14,00	140,0	214,0
1326054	2300-0087	14,25	14,25	144,0	220,0
1168284	2300-0088	14,50	14,50	144,0	220,0
1168285	2300-2194	14,75	14,75	144,0	220,0
1168286	2300-0090	15,00	15,00	144,0	220,0
1326055	2300-0091	15,25	15,25	144,0	220,0
1261572	2300-0092	15,40	15,40	149,0	227,0
1168288	2300-0093	15,50	15,50	149,0	227,0
1256221	2300-2195	15,75	15,75	149,0	227,0
1174004	2300-0094	16,00	16,00	149,0	227,0

Артикул	Обозначение по ГОСТ	D, мм	d, мм	l, мм	L, мм
1174005	2300-0095	16,25	16,25	154,0	235,0
1326056	2300-0096	16,50	16,50	154,0	235,0
1256223	2300-2196	16,75	16,75	154,0	235,0
1174006	2300-0097	17,00	17,00	154,0	235,0
1174007	2300-0098	17,25	17,25	158,0	241,0
1326057	2300-0099	17,40	17,40	158,0	241,0
1174008	2300-2100	17,50	17,50	158,0	241,0
1174009	2300-2197	17,75	17,75	158,0	241,0
1174010	2300-0101	18,00	18,00	158,0	241,0
1174011	2300-0102	18,25	18,25	162,0	247,0
1326058	2300-0103	18,50	18,50	162,0	247,0
1174012	2300-0104	18,75	18,75	162,0	247,0
1326059	2300-0105	19,00	19,00	162,0	247,0
1174013	2300-0106	19,25	19,25	166,0	254,0
1326060	2300-0107	19,40	19,40	166,0	254,0
1174014	2300-0108	19,50	19,50	166,0	254,0
1174015	2300-2198	19,75	19,75	166,0	254,0
1168301	2300-0109	20,00	20,00	166,0	254,0

Свёрла спиральные с цилиндрическим хвостовиком. Длинная серия. Правые

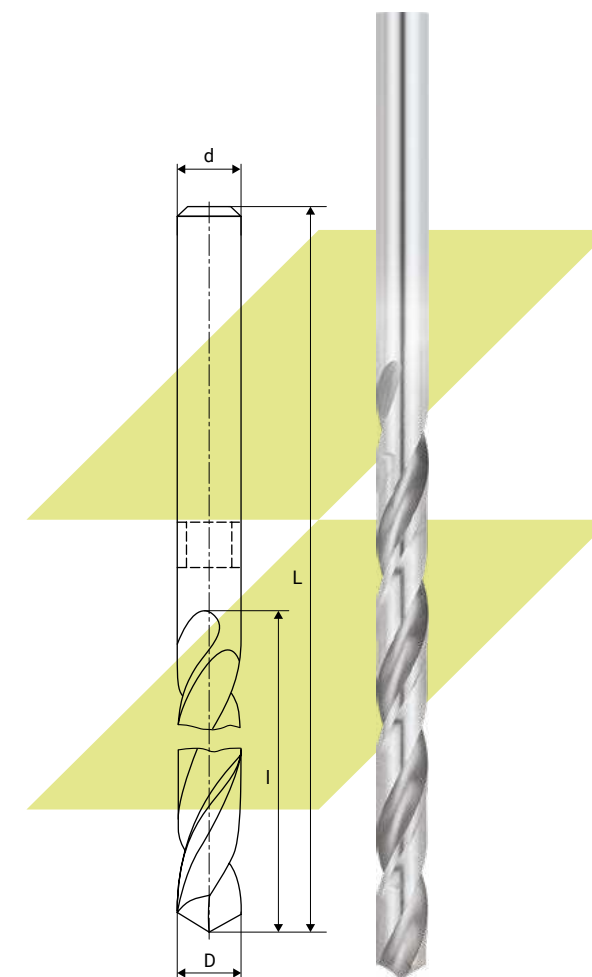
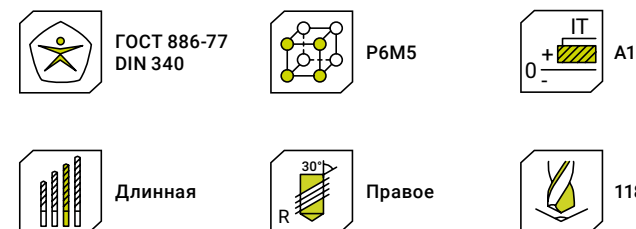
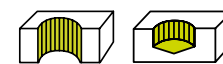

Артикул	Обозначение по ГОСТ	D, мм	d, мм	l, мм	L, мм
1335515	2300-6901	1,00	1,00	33,0	56,0
1377355	2300-6902	1,10	1,10	37,0	60,0
1377356	2300-6903	1,20	1,20	41,0	65,0
1345995	—	1,25	1,25	41,0	65,0
1377357	2300-6904	1,30	1,30	41,0	65,0
1377358	2300-6905	1,40	1,40	45,0	70,0
1377359	2300-6906	1,50	1,50	45,0	70,0
1377360	2300-6907	1,60	1,60	50,0	76,0
1377361	2300-6908	1,70	1,70	50,0	76,0
1377362	2300-6909	1,80	1,80	53,0	80,0
1377363	2300-6912	1,95	1,95	56,0	85,0
1335740	2300-6915	2,10	2,10	56,0	85,0
1345785	2300-6917	2,20	2,20	59,0	90,0
1273203	2300-6919	2,30	2,30	59,0	90,0
1167985	2300-6921	2,35	2,35	59,0	90,0
1335741	2300-6924	2,50	2,50	62,0	95,0
1335742	2300-6926	2,60	2,60	62,0	95,0
1335743	2300-6928	2,70	2,70	66,0	100,0
1335744	2300-6935	3,00	3,00	66,0	100,0
1335735	2300-6936	3,10	3,10	69,0	106,0
1276614	2300-6936	3,10	3,10	69,0	106,0
1335736	2300-6938	3,20	3,20	69,0	106,0
1276624	2300-6942	3,40	3,40	73,0	112,0
1276744	2300-6944	3,60	3,60	73,0	112,0
1276881	2300-6945	3,70	3,70	73,0	112,0
1335737	2300-6948	4,00	4,00	78,0	119,0
1335738	2300-6949	4,10	4,10	78,0	119,0
1335739	2300-6951	4,20	4,20	78,0	119,0
1284409	2300-6954	4,40	4,40	82,0	126,0
1269478	2300-6956	4,60	4,60	82,0	126,0
1269479	2300-6957	4,70	4,70	82,0	126,0
1284486	2300-6958	4,80	4,80	87,0	132,0
1335730	2300-6961	5,00	5,00	87,0	132,0
1335731	2300-6962	5,10	5,10	87,0	132,0

Артикул	Обозначение по ГОСТ	D, мм	d, мм	l, мм	L, мм
1335732	2300-0036	5,20	5,20	87,0	132,0
1331004	2300-2162	5,30	5,30	87,0	132,0
1284624	2300-0039	5,70	5,70	91,0	139,0
1284625	2300-1471	5,80	5,80	91,0	139,0
1335733	2300-0041	6,00	6,00	91,0	139,0
1289648	2300-0044	6,30	6,30	97,0	148,0
1284727	2300-0045	6,50	6,50	97,0	148,0
1269483	2300-2166	6,60	6,60	97,0	148,0
1284708	2300-2168	6,90	6,90	102,0	156,0
1284709	2300-0047	7,00	7,00	102,0	156,0
1284752	2300-0048	7,10	7,10	102,0	156,0
1284753	2300-0049	7,20	7,20	102,0	156,0

Артикул	Обозначение по ГОСТ	D, мм	d, мм	l, мм	L, мм
1284783	2300-0051	7,50	7,50	102,0	156,0
1377343	2300-0052	7,60	7,60	109,0	165,0
1335734	2300-0055	8,00	8,00	109,0	165,0
1284826	2300-0058	8,30	8,30	109,0	165,0
1284827	2300-0059	8,40	8,40	109,0	165,0
1417110	2300-1473	8,50	8,50	109,0	165,0
1284864	2300-1474	8,60	8,60	115,0	175,0
1271963	2300-0061	8,70	8,70	115,0	175,0
1286950	2300-0064	9,20	9,20	115,0	175,0
1287002	2300-0065	9,50	9,50	115,0	175,0
1271984	2300-0067	9,70	9,70	121,0	184,0

Свёрла спиральные с цилиндрическим хвостовиком. Длинная серия. Правые

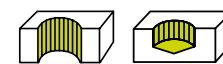

ГОСТ 886-77
DIN 340

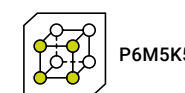

P6M5K5

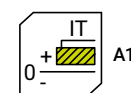

IT A1

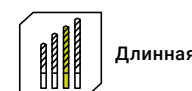

Длинная



Правое



135°

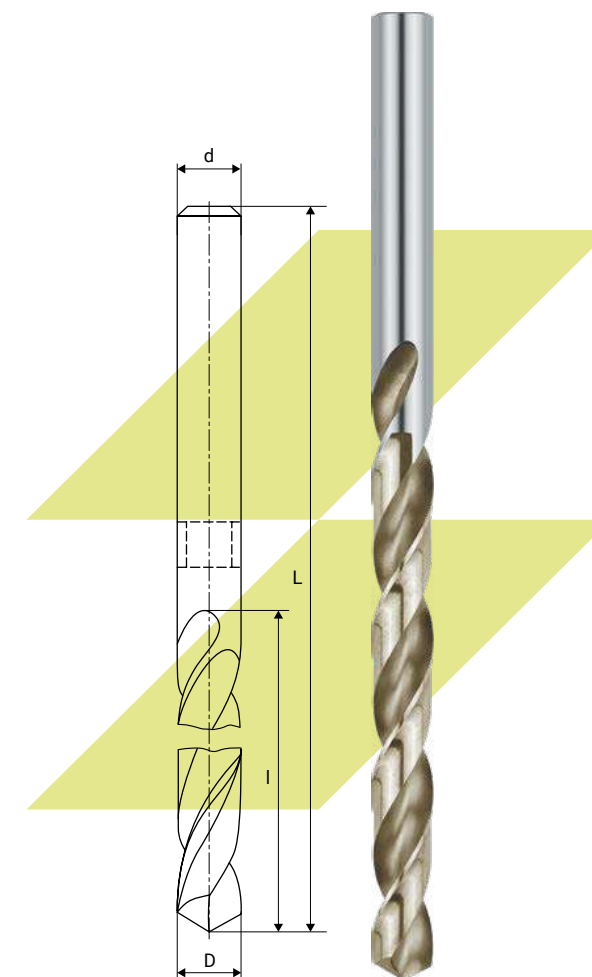

Артикул	Обозначение по ГОСТ	D, мм	d, мм	l, мм	L, мм
1343155	2300-6904	1,30	1,30	41,0	65,0
1256198	2300-6906	1,50	1,50	45,0	70,0
1293298	2300-6907	1,60	1,60	50,0	76,0
1256199	2300-6911	1,90	1,90	53,0	80,0
1256200	2300-6913	2,00	2,00	56,0	85,0
1273217	2300-6919	2,30	2,30	59,0	90,0
1220852	2300-6924	2,50	2,50	62,0	95,0
1256201	2300-6928	2,70	2,70	66,0	100,0
1256202	2300-6931	2,80	2,80	66,0	100,0
1256203	2300-6935	3,00	3,00	66,0	100,0
1293299	2300-6936	3,10	3,10	69,0	106,0
1293300	2300-6937	3,15	3,15	69,0	106,0
1168022	2300-0018	3,20	3,20	69,0	106,0
1256205	2300-6939	3,30	3,30	69,0	106,0
1582164	2300-6944	3,60	3,60	73,0	112,0
1256206	2300-6946	3,80	3,80	78,0	119,0
1256207	2300-6948	4,00	4,00	78,0	119,0
1256208	2300-6949	4,10	4,10	78,0	119,0
1256209	2300-6951	4,20	4,20	78,0	119,0
1293301	2300-6955	4,50	4,50	82,0	126,0
1284431	2300-0032	4,60	4,60	82,0	126,0
1256210	2300-6958	4,80	4,80	87,0	132,0
1256822	2300-6961	5,00	5,00	87,0	132,0
1335516	2300-6962	5,10	5,10	87,0	132,0
1293302	2300-0037	5,50	5,50	91,0	139,0
1335347	2300-0038	5,60	5,60	91,0	139,0
1343156	2300-1471	5,80	5,80	91,0	139,0
1293303	2300-0041	6,00	6,00	91,0	139,0
1256211	2300-0042	6,10	6,10	97,0	148,0
1293304	2300-0043	6,20	6,20	97,0	148,0
1284696	2300-0044	6,30	6,30	97,0	148,0
1269482	2300-2165	6,40	6,40	97,0	148,0
1256212	2300-0045	6,50	6,50	97,0	148,0
1262889	2300-6978	6,60	6,60	97,0	148,0

Артикул	Обозначение по ГОСТ	D, мм	d, мм	l, мм	L, мм
1293305	2300-0046	6,70	6,70	97,0	148,0
1293306	2300-2167	6,80	6,80	102,0	156,0
1343157	2300-0047	7,00	7,00	102,0	156,0
1284756	2300-0048	7,10	7,10	102,0	156,0
1168188	2300-6985	7,20	7,20	102,0	156,0
1284755	2300-1472	7,30	7,30	102,0	156,0
1271987	2300-0051	7,50	7,50	102,0	156,0
1293103	2300-0055	8,00	8,00	109,0	165,0
1330983	2300-0058	8,30	8,30	109,0	165,0
1284828	2300-0059	8,40	8,40	109,0	165,0
1293307	2300-1473	8,50	8,50	109,0	165,0
1331108	2300-1474	8,60	8,60	115,0	175,0
1271975	2300-0061	8,70	8,70	115,0	175,0
1284866	2300-2171	8,80	8,80	115,0	175,0
1284895	2300-0062	8,90	8,90	115,0	175,0
1256431	2300-0063	9,00	9,00	115,0	175,0
1293308	2300-2173	9,30	9,30	115,0	175,0
1256432	2300-0065	9,50	9,50	115,0	175,0
1293310	2300-7019	10,30	10,30	121,0	184,0
1293054	2300-7022	10,50	10,50	121,0	184,0
1293311	2300-7025	10,80	10,80	128,0	195,0
1293055	2300-7027	11,00	11,00	128,0	195,0
1293312	2300-7029	11,20	11,20	128,0	195,0
1293313	2300-7033	11,50	11,50	128,0	195,0
1293314	2300-7035	11,70	11,70	128,0	195,0
1293315	2300-7036	11,80	11,80	128,0	195,0
1256216	2300-7038	12,00	12,00	134,0	205,0
1293316	2300-7042	12,30	12,30	134,0	205,0

Артикул	Обозначение по ГОСТ	D, мм	d, мм	l, мм	L, мм
1293056	2300-7044	12,50	12,50	134,0	205,0
1293317	2300-7047	12,80	12,80	134,0	205,0
1293057	2300-7049	13,00	13,00	134,0	205,0
1293318	2300-7053	13,30	13,30	140,0	214,0
1293319	2300-7055	13,50	13,50	140,0	214,0
1293320	2300-7059	13,80	13,80	140,0	214,0
1293058	2300-7062	14,00	14,00	140,0	214,0
1293321	2300-7064	14,50	14,50	144,0	220,0
1293322	2300-7065	14,75	14,75	144,0	220,0
1293323	2300-7066	15,00	15,00	144,0	220,0
1293324	2300-7069	15,50	15,50	149,0	227,0
1256222	2300-7072	16,00	16,00	149,0	227,0
1293325	2300-7073	16,25	16,25	154,0	235,0
1293326	2300-7074	16,50	16,50	154,0	235,0
1293327	2300-7075	16,75	16,75	154,0	235,0
1293328	2300-7076	17,00	17,00	154,0	235,0
1293329	2300-7079	17,50	17,50	158,0	241,0
1293330	2300-7081	17,75	17,75	158,0	241,0
1293059	2300-7082	18,00	18,00	158,0	241,0
1293331	2300-7083	18,25	18,25	162,0	247,0
1293332	2300-7084	18,50	18,50	162,0	247,0
1293333	2300-7085	18,75	18,75	162,0	247,0
1293060	2300-7086	19,00	19,00	162,0	247,0
1293334	2300-7087	19,25	19,25	166,0	254,0
1293335	2300-7089	19,50	19,50	166,0	254,0
1293336	2300-7091	19,75	19,75	166,0	254,0
1256224	2300-7092	20,00	20,00	166,0	254,0

Свёрла спиральные с цилиндрическим хвостовиком. Длинная серия. Правые

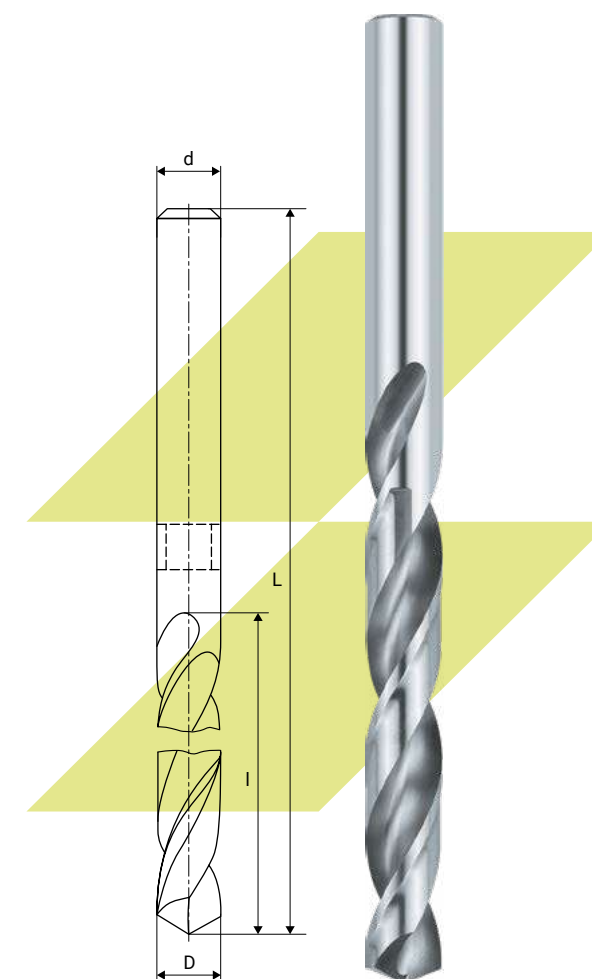
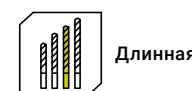
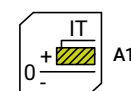
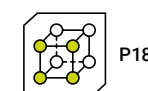
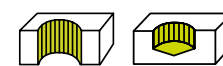

Артикул	Обозначение по ГОСТ	D, мм	d, мм	l, мм	L, мм
1331172	2300-6904	1,30	1,30	41,0	65,0
1167974	2300-0004	2,15	2,15	59,0	90,0
1167977	2300-0005	2,20	2,20	59,0	90,0
1331177	2300-6918	2,25	2,25	59,0	90,0
1331180	2300-6926	2,60	2,60	62,0	95,0
1331182	2300-6929	2,75	2,75	66,0	100,0
1168004	2300-0014	2,90	2,90	66,0	100,0
1331183	2300-6934	2,95	2,95	66,0	100,0
1356200	2300-6936	3,10	3,10	69,0	106,0
1331185	2300-6938	3,20	3,20	69,0	106,0
1331189	2300-6945	3,70	3,70	73,0	112,0
1168042	2300-0025	3,80	3,80	78,0	119,0
1168045	2300-0026	3,90	3,90	78,0	119,0
1356201	2300-6951	4,20	4,20	78,0	119,0
1168079	2300-0033	4,80	4,80	87,0	132,0
1168082	2300-2161	4,90	4,90	87,0	132,0
1518092	2300-0037	5,50	5,50	91,0	139,0
1518093	2300-0041	6,00	6,00	91,0	139,0
1518094	2300-0042	6,10	6,10	97,0	148,0
1518095	2300-0045	6,50	6,50	97,0	148,0
1256921	2300-6979	6,70	6,70	97,0	148,0
1518096	2300-0047	7,00	7,00	102,0	156,0
1168183	2300-6984	7,10	7,10	102,0	156,0
1518097	2300-0051	7,50	7,50	102,0	156,0
1284787	2300-6989	7,60	7,60	109,0	165,0
1518098	2300-0054	7,80	7,80	109,0	165,0
1326703	2300-6996	8,20	8,20	109,0	165,0
1168219	2300-7001	8,60	8,60	115,0	175,0
1168224	2300-7004	8,90	8,90	115,0	175,0
1416977	2300-7009	9,40	9,40	115,0	175,0
1261447	2300-0109	20,00	20,00	166,0	254,0

Обработка отверстий

Обработка отверстий

Свёрла спиральные с цилиндрическим хвостовиком. Сверхдлинные. Правые

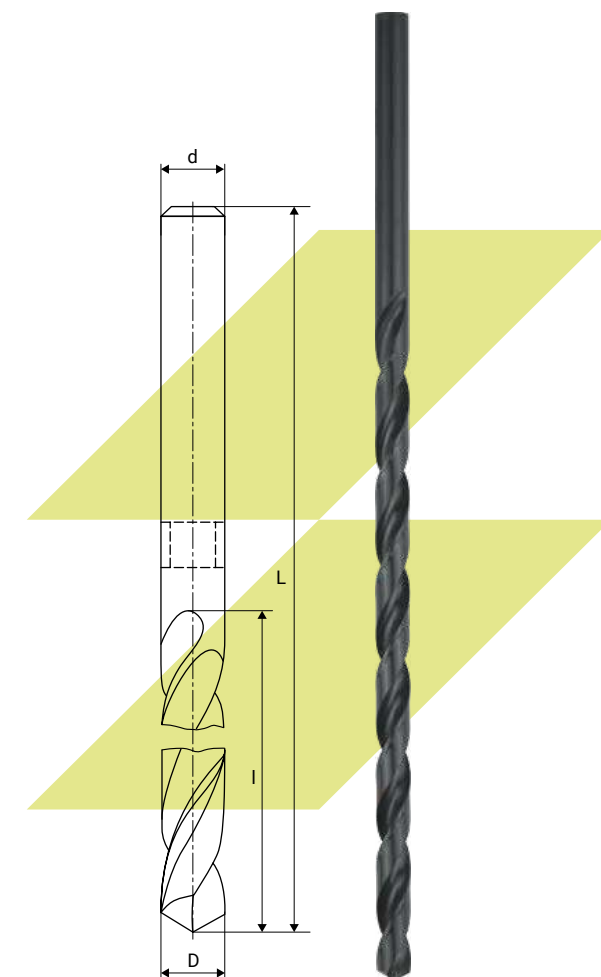
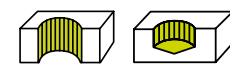

Артикул		D, мм	d, мм	I, мм	L, мм
1177969	●	2,0	2,0	100,0	160,0
1177970	●	2,5	2,5	100,0	160,0
1177971	●	3,0	3,0	110,0	160,0
1177972	●	3,5	3,5	110,0	160,0
1177973	●	4,0	4,0	110,0	160,0
1177974	●	4,5	4,5	150,0	200,0
1177975	●	5,0	5,0	150,0	200,0
1177976	●	5,0	5,0	200,0	250,0
1168102	●	5,2	5,2	100,0	300,0
1168109	●	5,4	5,4	250,0	350,0
1177977	●	6,0	6,0	150,0	200,0
1177978	●	6,0	6,0	200,0	250,0
1177979	●	6,0	6,0	230,0	300,0
1177980	●	6,0	6,0	300,0	400,0
1345795	●	6,2	6,2	100,0	350,0
1284785	●	6,3	6,3	95,0	345,0
1168149	●	6,3	6,3	190,0	245,0
1168157	●	6,4	6,4	105,0	345,0
1168162	●	6,5	6,5	100,0	300,0
1168165	●	6,6	6,6	225,0	315,0
1177981	●	7,5	7,5	200,0	250,0
1177982	●	8,0	8,0	150,0	200,0
1177983	●	8,0	8,0	200,0	250,0
1177984	●	8,0	8,0	250,0	350,0
1177985	●	8,0	8,0	300,0	400,0
1330791	●	8,7	8,7	170,0	225,0
1177986	●	9,0	9,0	250,0	350,0
1177987	●	9,0	9,0	300,0	400,0
1177988	●	10,0	10,0	200,0	250,0
1177989	●	10,0	10,0	250,0	300,0
1177990	●	10,0	10,0	300,0	400,0
1177991	●	11,0	11,0	250,0	350,0
1177992	●	11,0	11,0	300,0	400,0
1289381	●	11,7	11,7	110,0	310,0

Артикул		D, мм	d, мм	I, мм	L, мм
1177993	●	12,0	12,0	200,0	250,0
1177994	●	12,0	12,0	250,0	350,0
1177995	●	12,0	12,0	300,0	400,0

Свёрла спиральные малоразмерные диаметром от 0,1 до 1,5 мм с утолщенным цилиндрическим хвостовиком. Короткая серия. Правые

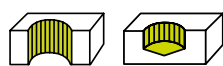

ГОСТ 8034-76

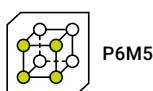

P6M5



118°



Короткая



Правое

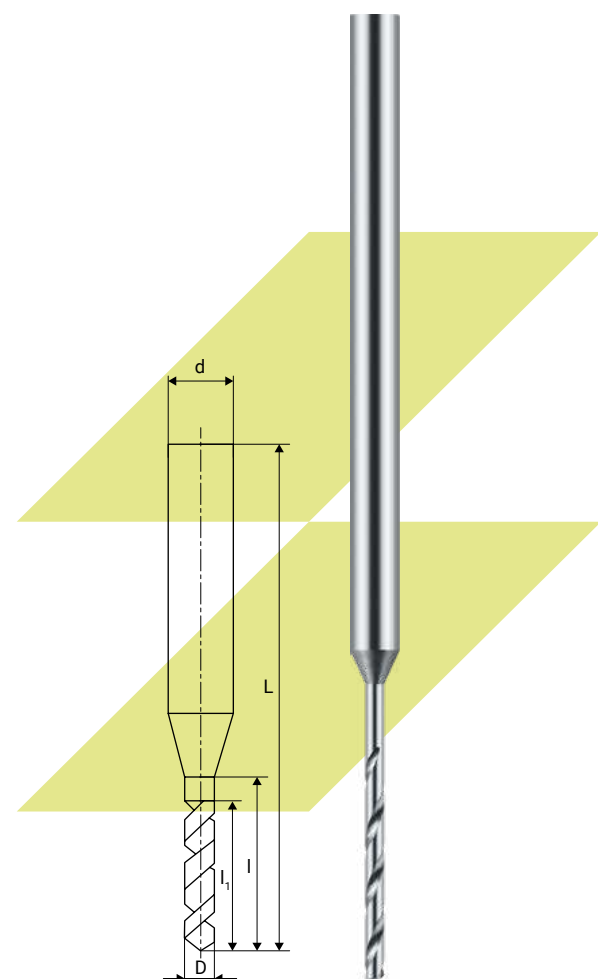

Артикул	Обозначение по ГОСТ	D, мм	d, мм	I ₁ , мм	I, мм	L, мм
1170184	2309-0503	0,105	1,2	0,6	1,0	14,0
1170195	2309-0531	0,160	1,2	0,8	1,2	16,0
1218879	2309-0551	0,200	1,2	1,3	1,8	18,0
1218880	2309-0555	0,210	1,2	1,3	1,8	18,0
1236910	2309-0557	0,220	1,2	1,3	1,8	18,0
1170207	2309-0561	0,230	1,2	1,3	1,8	18,0
1170212	2309-0563	0,240	1,2	1,3	1,8	18,0
1218882	2309-0565	0,250	1,2	1,7	2,2	18,0
1170217	2309-0567	0,260	1,2	1,7	2,2	18,0
1170219	2309-0571	0,270	1,2	1,7	2,2	18,0
1170223	2309-0575	0,290	1,2	1,7	2,2	18,0
1254691	2309-0581	0,310	1,2	2,2	2,8	20,0
1170236	2309-0587	0,330	1,2	2,2	2,8	20,0
1170243	2309-0595	0,360	1,2	2,2	2,8	20,0
1267150	2309-0597	0,370	1,2	2,2	2,8	20,0
1170245	2309-0601	0,380	1,2	2,2	2,8	20,0
1170248	2309-0603	0,390	1,2	3,0	3,6	22,0
1218884	2309-0605	0,400	1,2	3,0	3,6	22,0
1218885	2309-0611	0,420	1,2	3,0	3,6	22,0
1170260	2309-0613	0,430	1,2	3,0	3,6	22,0
1185644	2309-0617	0,450	1,2	3,0	3,6	22,0
1323358	2309-0621	0,460	1,2	3,0	3,6	22,0
1170271	2309-0623	0,470	1,2	3,0	3,6	22,0
1261586	2309-0625	0,480	1,2	3,0	3,6	22,0
1185647	2309-0631	0,500	1,2	3,5	4,0	22,0
1261587	2309-0633	0,510	1,2	3,5	4,0	22,0
1479789	2309-0637	0,530	1,2	3,5	4,0	22,0
1178678	2309-0643	0,550	1,2	4,0	4,5	25,0
1170298	2309-0645	0,560	1,2	4,0	4,5	25,0
1254692	2309-0647	0,570	1,2	4,0	4,5	25,0
1185648	2309-0651	0,580	1,2	4,0	4,5	25,0
1185650	2309-0653	0,600	1,2	4,0	4,5	25,0
1178679	2309-0655	0,615	1,2	4,2	5,0	25,0
1170310	2309-0657	0,630	1,2	4,2	5,0	25,0

Артикул	Обозначение по ГОСТ	D, мм	d, мм	I ₁ , мм	I, мм	L, мм
1178680	2309-0661	0,650	1,2	4,2	5,0	25,0
1170317	2309-0663	0,670	1,2	4,2	5,0	25,0
1261591	2309-0665	0,700	1,2	4,5	5,6	25,0
1261593	2309-0667	0,710	1,2	4,5	5,6	25,0
1178686	2309-0673	0,750	1,2	4,5	5,6	25,0
1170332	2309-0675	0,780	1,2	5,0	6,3	25,0
1284339	2309-0677	0,800	1,2	5,0	6,3	25,0
1178692	2309-0683	0,850	1,2	5,0	6,3	25,0
1343278	2309-0687	0,900	1,2	5,0	6,3	25,0
1261594	2309-0691	0,925	1,2	5,5	7,1	25,0
1583130	2309-0693	0,950	1,2	6,0	8,0	25,0

Артикул	Обозначение по ГОСТ	D, мм	d, мм	I ₁ , мм	I, мм	L, мм
1258404	2309-0695	0,975	1,2	6,0	8,0	25,0
1185653	2309-0697	1,000	1,2	6,0	8,0	25,0
1220070	2309-0701	1,050	1,6	6,0	8,0	32,0
1330851	2309-0705	1,150	1,6	7,0	9,0	32,0
1330852	2309-0707	1,200	1,6	8,0	10,0	32,0
1330853	2309-0711	1,250	1,6	8,0	10,0	32,0
1185656	2309-0713	1,300	1,6	8,0	10,0	32,0
1330854	2309-0715	1,350	1,6	9,0	11,2	32,0
1330855	2309-0717	1,400	1,6	9,0	11,2	32,0
1330856	2309-0721	1,450	1,6	9,0	11,2	32,0
1330857	2309-0723	1,500	1,6	9,0	11,2	32,0

Свёрла спиральные малоразмерные диаметром от 0,1 до 1,5 мм с утолщенным цилиндрическим хвостовиком. Длинная серия. Правые

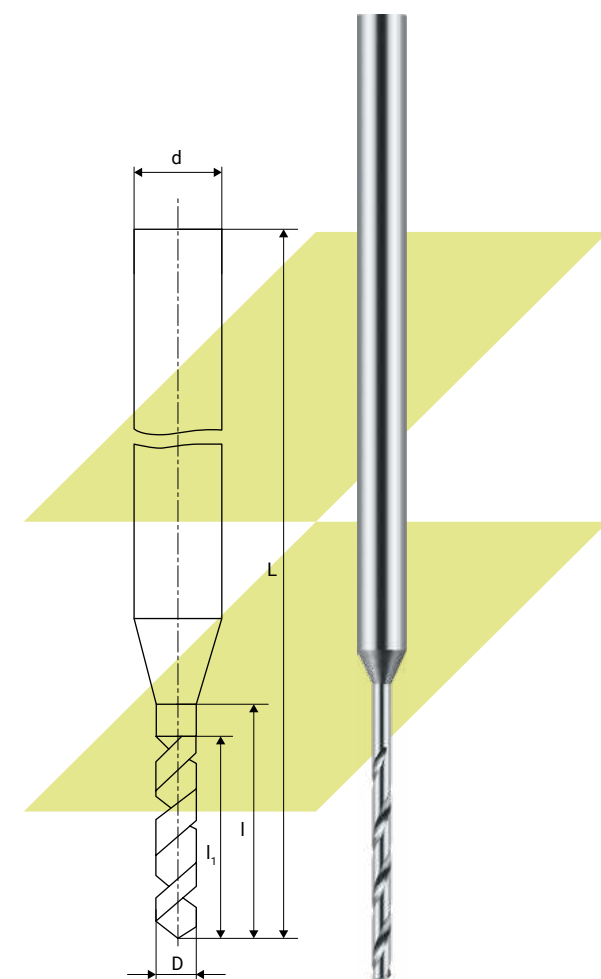
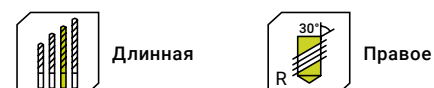

Артикул	Обозначение по ГОСТ	D, мм	d, мм	I ₁ , мм	I, мм	L, мм
1170185	2309-0731	0,110	1,2	1,2	1,6	14,0
1170186	2309-0735	0,120	1,2	1,2	1,6	14,0
1170187	2309-0741	0,130	1,2	1,2	1,6	14,0
1170188	2309-0745	0,140	1,2	1,2	1,6	14,0
1170194	2309-0755	0,160	1,2	1,6	2,0	16,0
1170196	2309-0761	0,170	1,2	1,6	2,0	16,0
1170198	2309-0765	0,180	1,2	1,6	2,0	16,0
1170199	2309-0771	0,190	1,2	1,6	2,0	16,0
1185643	2309-0775	0,200	1,2	2,0	2,5	18,0
1170204	2309-0781	0,210	1,2	2,0	2,5	18,0
1170206	2309-0783	0,220	1,2	2,0	2,5	18,0
1236911	2309-0785	0,230	1,2	2,0	2,5	18,0
1218881	2309-0787	0,240	1,2	2,0	2,5	18,0
1170213	2309-0791	0,250	1,2	3,0	4,0	18,0
1170216	2309-0793	0,260	1,2	3,0	4,0	18,0
1326397	2309-0795	0,270	1,2	3,0	4,0	18,0
1170220	2309-0797	0,280	1,2	3,0	4,0	18,0
1170222	2309-0801	0,290	1,2	3,0	4,0	18,0
1479786	2309-0803	0,300	1,2	3,0	4,0	18,0
1170228	2309-0805	0,310	1,2	4,0	5,0	20,0
1170230	2309-0811	0,320	1,2	4,0	5,0	20,0
1416734	2309-0813	0,330	1,2	4,0	5,0	20,0
1170237	2309-0815	0,340	1,2	4,0	5,0	20,0
1236383	2309-0817	0,350	1,2	4,0	5,0	20,0
1218883	2309-0821	0,360	1,2	4,0	5,0	20,0
1236384	2309-0823	0,370	1,2	4,0	5,0	20,0
1253814	2309-0825	0,380	1,2	4,0	5,0	20,0
1234908	2309-0827	0,390	1,2	5,0	6,0	22,0
1479787	2309-0831	0,400	1,2	5,0	6,0	22,0
1238184	2309-0833	0,410	1,2	5,0	6,0	22,0
1479788	2309-0837	0,430	1,2	5,0	6,0	22,0
1261584	2309-0837	0,430	1,2	5,0	6,0	22,0
1261585	2309-0843	0,450	1,2	5,0	6,0	22,0
1170265	2309-0845	0,460	1,2	5,0	6,0	22,0

Артикул	Обозначение по ГОСТ	D, мм	d, мм	I ₁ , мм	I, мм	L, мм
1185645	2309-0847	0,470	1,2	5,0	6,0	22,0
1170272	2309-0851	0,480	1,2	5,0	6,0	22,0
1185646	2309-0855	0,500	1,2	6,0	8,0	22,0
1261588	2309-0857	0,510	1,2	6,0	8,0	22,0
1236385	2309-0861	0,520	1,2	6,0	8,0	22,0
1479790	2309-0863	0,530	1,2	6,0	8,0	22,0
1170293	2309-0865	0,540	1,2	8,0	10,0	25,0
1178677	2309-0867	0,550	1,2	8,0	10,0	25,0
1218886	2309-0871	0,560	1,2	8,0	10,0	25,0
1261589	2309-0875	0,580	1,2	8,0	10,0	25,0
1185649	2309-0877	0,600	1,2	8,0	10,0	25,0
1335533	2309-0883	0,630	1,2	8,0	10,0	25,0
1261590	2309-0885	0,650	1,2	8,0	10,0	25,0
1178682	2309-0887	0,670	1,2	8,0	10,0	25,0

Артикул	Обозначение по ГОСТ	D, мм	d, мм	I ₁ , мм	I, мм	L, мм
1185651	2309-0891	0,700	1,2	8,0	10,0	25,0
1261592	2309-0893	0,710	1,2	8,0	10,0	25,0
1178684	2309-0895	0,730	1,2	8,0	10,0	25,0
1178685	2309-0897	0,750	1,2	8,0	10,0	25,0
1178688	2309-0901	0,780	1,2	9,0	11,2	25,0
1335534	2309-0903	0,800	1,2	9,0	11,2	25,0
1178689	2309-0905	0,825	1,2	9,0	11,2	25,0
1178691	2309-0907	0,850	1,2	9,0	11,2	25,0
1254693	2309-0911	0,875	1,2	9,0	11,2	25,0
1185652	2309-0913	0,900	1,2	9,0	11,2	25,0
1178693	2309-0917	0,950	1,2	9,0	11,2	25,0
1284340	2309-0923	1,000	1,2	9,0	11,2	25,0
1258419	—	1,100	1,2	10,0	12,2	32,0
1185655	—	1,100	1,6	10,0	12,2	32,0

Свёрла спиральные малоразмерные диаметром от 0,1 до 1,5 мм с утолщенным цилиндрическим хвостовиком. Короткая серия. Левые

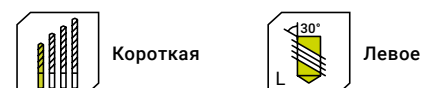

Артикул	Обозначение по ГОСТ	D, мм	d, мм	I ₁ , мм	I, мм	L, мм
1170203	2309-0552	0,200	1,2	1,3	1,8	18,0
1170218	2309-0568	0,260	1,2	1,7	2,2	18,0
1170249	2309-0604	0,390	1,2	3,0	3,6	22,0
1170253	2309-0606	0,400	1,2	3,0	3,6	22,0
1235765	2309-0608	0,410	1,2	3,0	3,6	22,0
1170264	2309-0618	0,450	1,2	3,0	3,6	22,0
1170267	2309-0622	0,460	1,2	3,0	3,6	22,0
1170277	2309-0628	0,490	1,2	3,5	4,0	22,0
1170282	2309-0632	0,500	1,2	3,5	4,0	22,0
1170285	2309-0634	0,510	1,2	3,5	4,0	22,0
1170289	2309-0636	0,520	1,2	3,5	4,0	22,0
1170292	2309-0638	0,530	1,2	3,5	4,0	22,0
1170296	2309-0644	0,550	1,2	4,0	4,5	25,0
1234910	2309-0654	0,600	1,2	4,0	4,5	25,0
1170308	2309-0656	0,620	1,2	4,2	5,0	25,0
1178681	2309-0662	0,650	1,2	4,2	5,0	25,0
1170322	2309-0666	0,700	1,2	4,5	5,6	25,0
1170323	2309-0668	0,710	1,2	4,5	5,6	25,0
1170326	2309-0672	0,730	1,2	4,5	5,6	25,0
1178687	2309-0674	0,750	1,2	4,5	5,6	25,0
1479791	2309-0678	0,800	1,2	5,0	6,3	25,0
1170340	2309-0684	0,850	1,2	5,0	6,3	25,0
1218888	2309-0688	0,900	1,2	5,0	6,3	25,0

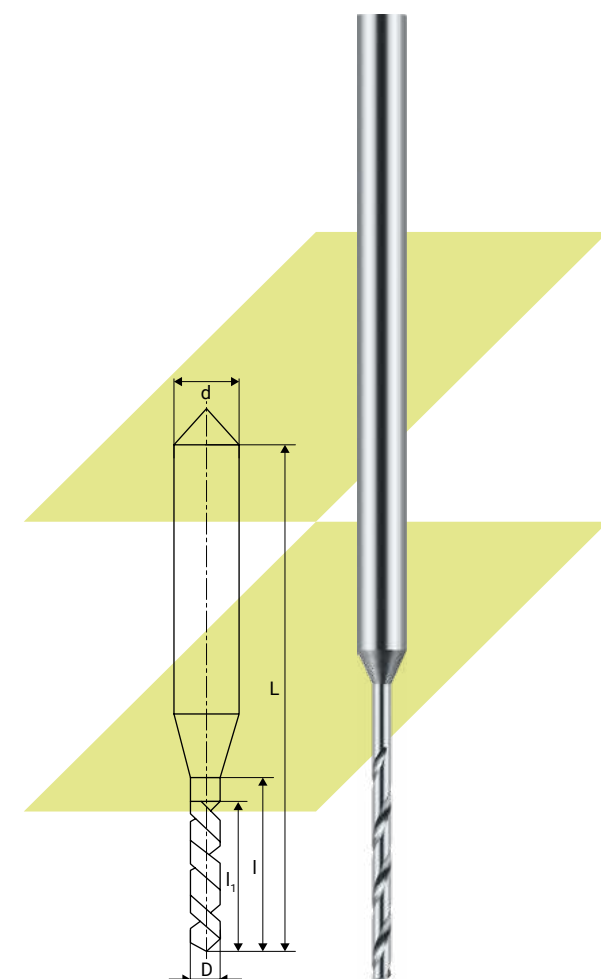

Свёрла спиральные малоразмерные диаметром от 0,1 до 1,5 мм с утолщенным цилиндрическим хвостовиком. Длинная серия. Левые

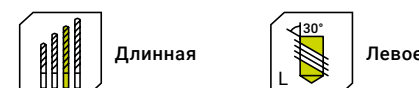

Артикул	Обозначение по ГОСТ	D, мм	d, мм	I ₁ , мм	I, мм	L, мм
1170190	2309-0752	0,150	1,2	1,6	2,0	16,0
1236909	2309-0766	0,180	1,2	1,6	2,0	16,0
1243996	2309-0776	0,200	1,2	2,0	2,5	18,0
1170210	2309-0788	0,240	1,2	2,0	2,5	18,0
1170214	2309-0792	0,250	1,2	3,0	4,0	18,0
1170225	2309-0804	0,300	1,2	3,0	4,0	18,0
1335462	2309-0806	0,310	1,2	4,0	5,0	20,0
1170231	2309-0812	0,320	1,2	4,0	5,0	20,0
1170235	2309-0814	0,330	1,2	4,0	5,0	20,0
1477826	2309-0822	0,360	1,2	4,0	5,0	20,0
1170247	2309-0828	0,390	1,2	5,0	6,0	22,0
1343438	2309-0832	0,400	1,2	5,0	6,0	22,0
1170269	2309-0848	0,470	1,2	5,0	6,0	22,0
1170273	2309-0852	0,480	1,2	5,0	6,0	22,0
1234909	2309-0856	0,500	1,2	6,0	8,0	22,0
1178683	2309-0888	0,670	1,2	8,0	8,0	25,0
1170320	2309-0892	0,700	1,2	8,0	8,0	25,0
1218887	2309-0896	0,730	1,2	8,0	8,0	25,0
1178690	2309-0906	0,830	1,2	9,0	10,0	25,0
1170338	2309-0908	0,850	1,2	9,0	10,0	25,0
1170343	2309-0914	0,900	1,2	9,0	10,0	25,0

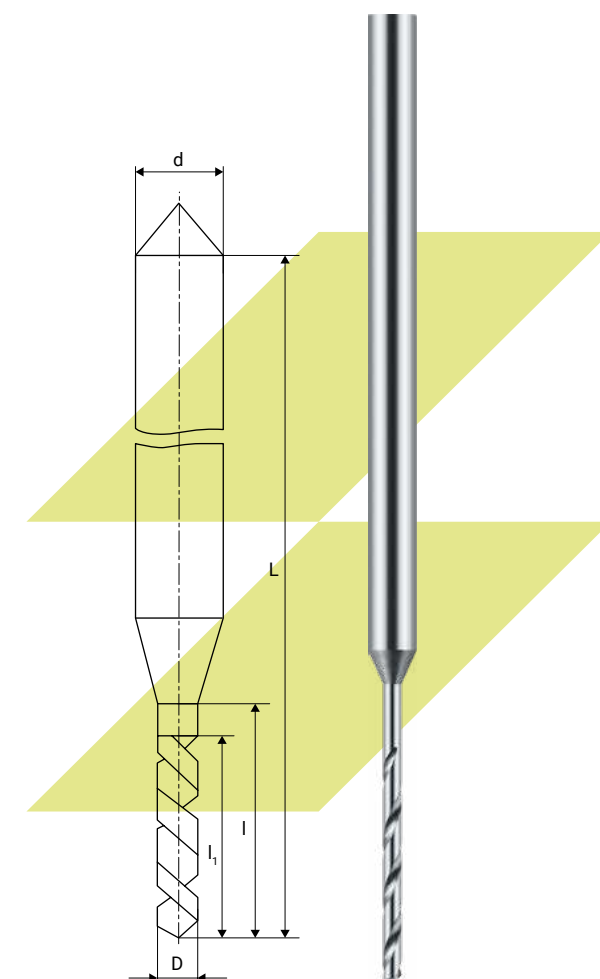

Свёрла спиральные с коническим хвостовиком. Средняя серия. Правые

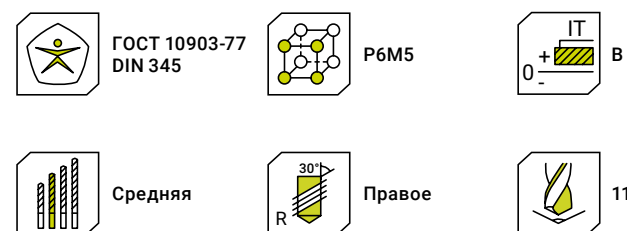

Артикул	Обозначение по ГОСТ	D, мм	Конус Морзе	I, мм	L, мм
1173950	—	4,00	KM1	47,0	128,0
1284923	—	4,20	KM1	47,0	128,0
1173951	—	4,50	KM1	47,0	128,0
1168659	2301-3001	5,00	KM1	52,0	133,0
1168660	2301-3002	5,20	KM1	52,0	133,0
1173952	—	5,30	KM1	57,0	138,0
1168661	2301-3003	5,50	KM1	57,0	138,0
1168663	2301-3004	5,80	KM1	57,0	138,0
1181214	—	5,90	KM1	57,0	138,0
1168671	2301-0001	6,00	KM1	57,0	138,0
1168677	—	6,30	KM1	57,0	138,0
1168679	2301-3005	6,40	KM1	57,0	138,0
1335532	2301-0005	6,50	KM1	63,0	144,0
1168684	2301-3006	6,60	KM1	63,0	144,0
1168687	—	6,70	KM1	63,0	144,0
1168691	2301-0189	6,80	KM1	69,0	150,0
1258359	—	6,90	KM1	69,0	150,0
1168694	2301-0007	7,00	KM1	69,0	150,0
1258422	—	7,10	KM1	69,0	150,0
1168699	—	7,30	KM1	69,0	150,0
1168701	2301-3007	7,40	KM1	69,0	150,0
1168703	2301-0011	7,50	KM1	69,0	150,0
1168705	2301-3008	7,60	KM1	75,0	156,0
1168707	—	7,70	KM1	75,0	156,0
1168709	2301-3567	7,80	KM1	75,0	156,0
1168714	2301-0015	8,00	KM1	75,0	156,0
1168716	—	8,10	KM1	75,0	156,0
1168718	2301-0017	8,20	KM1	75,0	156,0
1378530	—	8,30	KM1	75,0	156,0
1168724	2301-3009	8,40	KM1	75,0	156,0
1168729	2301-0020	8,50	KM1	75,0	156,0
1168731	—	8,60	KM1	81,0	162,0
1168734	—	8,70	KM1	81,0	162,0
1289658	2301-0190	8,80	KM1	81,0	162,0

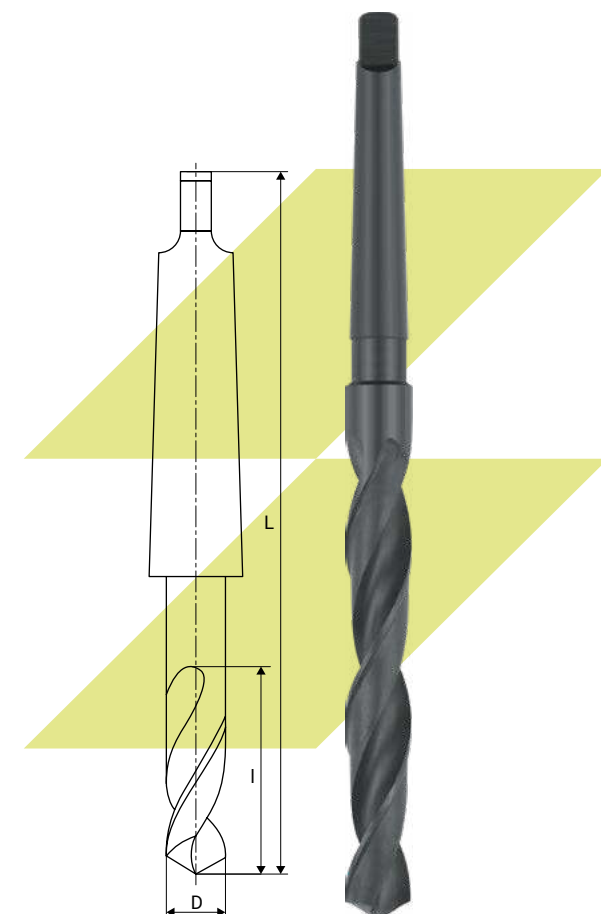

Артикул	Обозначение по ГОСТ	D, мм	Конус Морзе	I, мм	L, мм
1168739	—	8,90	KM1	81,0	162,0
1168745	2301-0023	9,00	KM1	81,0	162,0
1168748	—	9,10	KM1	81,0	162,0
1168753	2301-0024	9,20	KM1	81,0	162,0
1168755	—	9,30	KM1	81,0	162,0
1168758	—	9,40	KM1	81,0	162,0
1168761	2301-0025	9,50	KM1	81,0	162,0
1168765	—	9,60	KM1	87,0	168,0
1168767	—	9,70	KM1	87,0	168,0
1168768	2301-0191	9,80	KM1	87,0	168,0
1168771	—	9,90	KM1	87,0	168,0
1168776	2301-0028	10,00	KM1	87,0	168,0
1168778	—	10,10	KM1	87,0	168,0
1168783	2301-0030	10,20	KM1	87,0	168,0
1168786	—	10,30	KM1	87,0	168,0
1168789	—	10,40	KM1	87,0	168,0
1168795	2301-0032	10,50	KM1	87,0	168,0
1168797	—	10,60	KM1	94,0	175,0
1168799	—	10,70	KM1	94,0	175,0
1181210	2301-0192	10,80	KM1	94,0	175,0
1168805	—	10,90	KM1	94,0	175,0
1168809	2301-0034	11,00	KM1	94,0	175,0
1168811	—	11,10	KM1	94,0	175,0
1168817	2301-0035	11,20	KM1	94,0	175,0
1168818	—	11,30	KM1	94,0	175,0
1168820	—	11,40	KM1	94,0	175,0
1181211	2301-0036	11,50	KM1	94,0	175,0
1168826	—	11,60	KM1	94,0	175,0
1168828	—	11,70	KM1	94,0	175,0
1181212	2301-3586	11,80	KM1	94,0	175,0
1168831	—	11,90	KM1	101,0	182,0
1168837	2301-0039	12,00	KM1	101,0	182,0
1168840	—	12,10	KM1	101,0	182,0
1168844	2301-0194	12,20	KM1	101,0	182,0
1168847	—	12,30	KM1	101,0	182,0
1168850	—	12,40	KM1	101,0	182,0
1168854	2301-0040	12,50	KM1	101,0	182,0
1168859	—	12,60	KM1	101,0	182,0
1168862	—	12,70	KM1	101,0	182,0

Артикул	Обозначение по ГОСТ	D, мм	Конус Морзе	I, мм	L, мм
1168865	2301-0195	12,80	KM1	101,0	182,0
1168867	—	12,90	KM1	101,0	182,0
1168872	2301-0042	13,00	KM1	101,0	182,0
1582638	2301-0043	13,20	KM1	101,0	182,0
1168880	—	13,30	KM1	108,0	189,0
1256282	—	13,40	KM1	108,0	189,0
1168883	2301-0044	13,50	KM1	108,0	189,0
1168887	—	13,60	KM1	108,0	189,0
1168891	2301-3011	13,75	KM1	108,0	189,0
1168893	2301-0196	13,80	KM1	108,0	189,0
1168898	—	13,90	KM1	108,0	189,0
1168907	2301-0046	14,00	KM1	108,0	189,0
1181213	2301-3022	14,00	KM2	114,0	212,0
1168912	2301-0047	14,25	KM2	114,0	212,0
1168918	2301-0048	14,50	KM2	114,0	212,0
1168921	2301-0197	14,75	KM2	114,0	212,0
1168926	2301-0050	15,00	KM2	114,0	212,0
1168930	2301-0051	15,25	KM2	120,0	218,0
1179274	2301-0052	15,40	KM2	120,0	218,0
1168939	2301-0053	15,50	KM2	120,0	218,0
1168943	2301-0198	15,75	KM2	120,0	218,0
1417732	—	15,90	KM2	120,0	218,0
1168949	2301-0054	16,00	KM2	120,0	218,0
1168952	2301-0055	16,25	KM2	125,0	223,0
1168957	2301-0056	16,50	KM2	125,0	223,0
1168961	2301-0199	16,75	KM2	125,0	223,0
1168967	2301-0057	17,00	KM2	125,0	223,0
1168972	2301-0058	17,25	KM2	130,0	228,0
1289659	2301-0059	17,40	KM2	130,0	228,0
1168981	2301-0060	17,50	KM2	130,0	228,0
1168986	2301-0200	17,75	KM2	130,0	228,0
1168993	2301-0061	18,00	KM2	130,0	228,0
1168997	2301-0062	18,25	KM2	135,0	233,0
1169004	2301-0063	18,50	KM2	135,0	233,0
1169010	2301-0064	18,75	KM2	135,0	233,0
1169019	2301-0065	19,00	KM2	135,0	233,0
1169026	2301-0066	19,25	KM2	140,0	238,0
1169030	2301-0067	19,40	KM2	140,0	238,0
1169038	2301-0068	19,50	KM2	140,0	238,0

Артикул	Обозначение по ГОСТ	D, мм	Конус Морзе	I, мм	L, мм
1169044	2301-0201	19,75	KM2	140,0	238,0
1169047	2301-0069	20,00	KM2	140,0	238,0
1169050	2301-0202	20,25	KM2	145,0	243,0
1169055	2301-0070	20,50	KM2	145,0	243,0
1169061	2301-0071	20,75	KM2	145,0	243,0
1479852	2301-0072	20,90	KM2	145,0	243,0
1169069	2301-0073	21,00	KM2	145,0	243,0
1169073	2301-0074	21,25	KM2	150,0	248,0
1169078	2301-0075	21,50	KM2	150,0	248,0
1169081	2301-3034	21,75	KM2	150,0	248,0
1169088	2301-0076	22,00	KM2	150,0	248,0
1169091	2301-0203	22,25	KM2	150,0	248,0
1169095	2301-0077	22,50	KM2	155,0	253,0
1169100	2301-0078	22,75	KM2	155,0	253,0
1173953	2301-0079	23,00	KM2	155,0	253,0
1177522	2301-0080	23,25	KM3	155,0	276,0
1377860	2301-0081	23,50	KM3	155,0	276,0
1177523	2301-0204	23,75	KM3	160,0	281,0
1177524	2301-0083	24,00	KM3	160,0	281,0
1265733	2301-0084	24,25	KM3	160,0	281,0
1177525	2301-0085	24,50	KM3	160,0	281,0
1518190	2301-0086	24,75	KM3	160,0	281,0
1173940	2301-0087	25,00	KM3	160,0	281,0
1177526	2301-0205	25,25	KM3	165,0	286,0
1263083	2301-0088	25,50	KM3	165,0	286,0
1169172	2301-0206	25,75	KM3	165,0	286,0
1177527	2301-0089	26,00	KM3	165,0	286,0
1169182	2301-0090	26,25	KM3	165,0	286,0
1261576	2301-0092	26,50	KM3	165,0	286,0
1263084	2301-0207	26,75	KM3	170,0	291,0
1179275	2301-0094	27,00	KM3	170,0	291,0
1441454	2301-0095	27,25	KM3	170,0	291,0
1169209	2301-0096	27,50	KM3	170,0	291,0
1169217	2301-0208	27,75	KM3	170,0	291,0
1173941	2301-0098	28,00	KM3	170,0	291,0
1169230	2301-0209	28,25	KM3	175,0	296,0
1583123	2301-0099	28,50	KM3	175,0	296,0
1169246	2301-0210	28,75	KM3	175,0	296,0
1289661	2301-0100	29,00	KM3	175,0	296,0

Артикул	Обозначение по ГОСТ	D, мм	Конус Морзе	I, мм	L, мм
1169259	2301-0101	29,25	KM3	175,0	296,0
1169261	—	29,30	KM3	175,0	296,0
1335529	2301-0103	29,50	KM3	175,0	296,0
1261577	2301-3048	29,75	KM3	175,0	296,0
1173942	2301-0106	30,00	KM3	175,0	296,0
1441456	2301-0107	30,25	KM3	180,0	301,0
1441457	2301-0108	30,50	KM3	180,0	301,0
1169289	2301-0211	30,75	KM3	180,0	301,0
1417548	2301-0109	31,00	KM3	180,0	301,0
1169296	2301-0110	31,25	KM3	180,0	301,0
1417550	2301-0111	31,50	KM3	180,0	301,0
1260850	2301-0112	31,75	KM3	185,0	306,0
1261578	2301-3072	31,75	KM4	185,0	334,0
1173943	2301-0113	32,00	KM4	185,0	334,0
1173944	2301-0213	32,25	KM4	185,0	334,0
1173945	2301-0115	32,50	KM4	185,0	334,0
1441461	—	32,75	KM4	185,0	334,0
1335530	2301-0117	33,00	KM4	185,0	334,0
1583124	2301-0118	33,50	KM4	185,0	334,0
1335531	2301-0119	34,00	KM4	190,0	339,0
1169341	2301-0120	34,50	KM4	190,0	339,0
1173946	2301-0122	35,00	KM4	190,0	339,0
1441464	2301-0215	35,25	KM4	190,0	339,0
1583125	2301-0123	35,50	KM4	190,0	339,0
1169354	2301-0216	35,75	KM4	195,0	344,0
1173947	2301-0125	36,00	KM4	195,0	344,0
1265636	—	36,20	KM4	195,0	344,0
1441466	2301-0217	36,25	KM4	195,0	344,0
1169375	2301-0128	37,00	KM4	195,0	344,0
1583126	2301-0130	37,50	KM4	195,0	344,0
1169382	—	37,75	KM4	200,0	349,0
1417552	2301-0132	38,00	KM4	200,0	349,0
1583127	2301-0218	38,50	KM4	200,0	349,0
1416470	2301-0135	39,00	KM4	200,0	349,0
1169402	2301-0219	39,25	KM4	200,0	349,0
1169406	2301-0136	39,50	KM4	200,0	349,0
1173948	2301-0137	40,00	KM4	200,0	349,0
1441468	2301-0139	40,50	KM4	205,0	354,0
1417555	2301-0141	41,00	KM4	205,0	354,0

Артикул	Обозначение по ГОСТ	D, мм	Конус Морзе	I, мм	L, мм
1441470	2301-0220	41,25	KM4	205,0	354,0
1289663	2301-0144	42,00	KM4	205,0	354,0
1418600	2301-0221	42,50	KM4	205,0	354,0
1289665	2301-0146	43,00	KM4	210,0	359,0
1169434	2301-0222	43,25	KM4	210,0	359,0
1441472	2301-0147	43,50	KM4	210,0	359,0
1441474	2301-0149	44,00	KM4	210,0	359,0
1179276	2301-0153	45,00	KM4	210,0	359,0
1261579	2301-0223	45,25	KM4	215,0	364,0
1261580	2301-0224	45,50	KM4	215,0	364,0
1289666	2301-0154	46,00	KM4	215,0	364,0
1169457	2301-0159	47,50	KM4	215,0	364,0
1418655	2301-0161	48,00	KM4	215,0	364,0
1417556	2301-0164	49,00	KM4	220,0	369,0
1417558	2301-0165	49,50	KM4	220,0	369,0
1176022	2301-0166	50,00	KM4	220,0	369,0
1276294	2301-0168	51,00	KM5	225,0	412,0
1260507	2301-0170	52,00	KM5	225,0	412,0

Артикул	Обозначение по ГОСТ	D, мм	Конус Морзе	I, мм	L, мм
1289668	2301-0171	53,00	KM5	225,0	412,0
1169487	—	53,50	KM5	230,0	417,0
1289670	2301-0172	54,00	KM5	230,0	417,0
1261582	2301-0173	55,00	KM5	230,0	417,0
1261387	2301-0174	56,00	KM5	230,0	417,0
1325794	—	56,50	KM5	230,0	417,0
1177529	2301-0175	57,00	KM5	235,0	422,0
1174016	2301-0176	58,00	KM5	235,0	422,0
1179277	2301-3126	59,00	KM5	235,0	422,0
1174017	2301-0177	60,00	KM5	240,0	422,0
1173949	2301-0179	62,00	KM5	240,0	427,0
1174018	2301-0180	63,00	KM5	240,0	427,0
1261583	2301-3101	64,00	KM5	245,0	432,0
1174019	2301-0181	65,00	KM5	245,0	432,0
1174020	2301-0183	70,00	KM5	250,0	437,0
1174021	2301-0186	75,00	KM5	255,0	442,0
1174022	2301-0188	80,00	KM6	260,0	514,0

Свёрла спиральные с коническим хвостовиком. Средняя серия. Правые

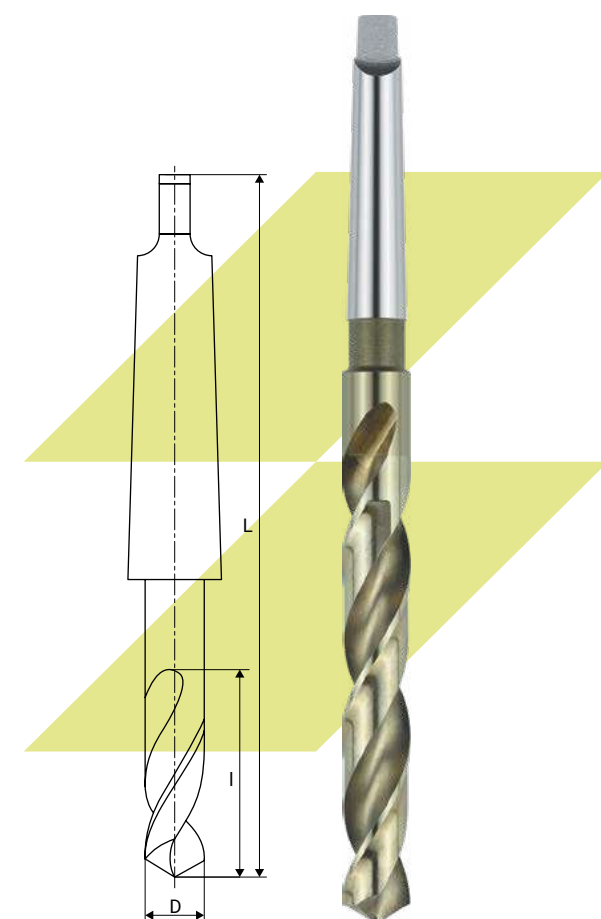
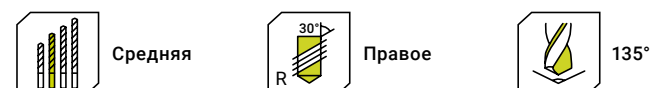
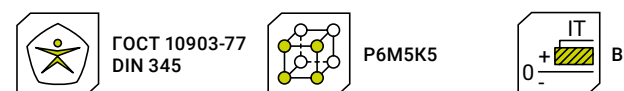

Артикул	Обозначение по ГОСТ	D, мм	Конус Морзе	I, мм	L, мм
1293125	2301-3001	5,00	KM1	52,0	133,0
1293126	—	5,10	KM1	52,0	133,0
1293127	2301-3002	5,20	KM1	52,0	133,0
1293128	—	5,30	KM1	57,0	138,0
1293129	—	5,40	KM1	57,0	138,0
1293130	2301-3003	5,50	KM1	57,0	138,0
1293131	—	5,60	KM1	57,0	138,0
1293132	—	5,70	KM1	57,0	138,0
1293133	2301-3004	5,80	KM1	57,0	138,0
1293134	—	5,90	KM1	57,0	138,0
1168667	2301-0001	6,00	KM1	57,0	138,0
1293135	—	6,10	KM1	57,0	138,0
1168675	2301-0003	6,20	KM1	63,0	144,0
1293136	—	6,30	KM1	63,0	144,0
1293137	2301-3005	6,40	KM1	63,0	144,0
1293138	2301-0005	6,50	KM1	63,0	144,0
1293139	2301-3006	6,60	KM1	63,0	144,0
1289575	—	6,70	KM1	63,0	144,0
1181215	2301-0189	6,80	KM1	69,0	150,0
1293140	—	6,90	KM1	69,0	150,0
1293141	2301-0007	7,00	KM1	69,0	150,0
1293142	—	7,10	KM1	69,0	150,0
1168696	2301-0009	7,20	KM1	69,0	150,0
1293143	—	7,30	KM1	69,0	150,0
1293144	2301-3007	7,40	KM1	69,0	150,0
1168704	2301-0011	7,50	KM1	69,0	150,0
1293145	2301-3008	7,60	KM1	75,0	156,0
1293146	—	7,70	KM1	75,0	156,0
1168710	2301-0014	7,80	KM1	75,0	156,0
1181216	2301-0015	8,00	KM1	75,0	156,0
1293147	—	8,10	KM1	75,0	156,0
1168719	2301-0017	8,20	KM1	75,0	156,0
1293148	—	8,30	KM1	75,0	156,0
1168723	2301-3009	8,40	KM1	75,0	156,0

Артикул	Обозначение по ГОСТ	D, мм	Конус Морзе	I, мм	L, мм
1181217	2301-0020	8,50	KM1	75,0	156,0
1289576	—	8,60	KM1	75,0	156,0
1293149	—	8,70	KM1	81,0	162,0
1168737	2301-0190	8,80	KM1	81,0	162,0
1293150	—	8,90	KM1	81,0	162,0
1181218	2301-0023	9,00	KM1	81,0	162,0
1293151	—	9,10	KM1	81,0	162,0
1168752	2301-0024	9,20	KM1	81,0	162,0
1293152	—	9,30	KM1	81,0	162,0
1293153	—	9,40	KM1	81,0	162,0
1583122	2301-0025	9,50	KM1	81,0	162,0
1293154	—	9,70	KM1	87,0	168,0
1168769	2301-0191	9,80	KM1	87,0	168,0
1518135	2301-0028	10,00	KM1	87,0	168,0
1289577	2301-0030	10,20	KM1	87,0	168,0
1293155	—	10,30	KM1	87,0	168,0
1289657	2301-0032	10,50	KM1	87,0	168,0
1168802	2301-0192	10,80	KM1	94,0	175,0
1293156	—	10,90	KM1	94,0	175,0
1181219	2301-0034	11,00	KM1	94,0	175,0
1293157	—	11,10	KM1	94,0	175,0
1258360	2301-0035	11,20	KM1	94,0	175,0
1293158	—	11,30	KM1	94,0	175,0
1293159	—	11,40	KM1	94,0	175,0
1168824	2301-0036	11,50	KM1	94,0	175,0
1293160	—	11,60	KM1	94,0	175,0
1293161	—	11,70	KM1	94,0	175,0
1293162	2301-3586	11,80	KM1	94,0	175,0
1181220	2301-0039	12,00	KM1	101,0	182,0
1293163	—	12,10	KM1	101,0	182,0
1293164	2301-0194	12,20	KM1	101,0	182,0
1293165	—	12,30	KM1	101,0	182,0
1293166	—	12,40	KM1	101,0	182,0
1181221	2301-0040	12,50	KM1	101,0	182,0
1293167	—	12,75	KM1	101,0	182,0
1168864	2301-0195	12,80	KM1	101,0	182,0
1258361	2301-0042	13,00	KM1	101,0	182,0
1168875	2301-0043	13,20	KM1	101,0	182,0
1284341	2301-0044	13,50	KM1	108,0	189,0

Артикул	Обозначение по ГОСТ	D, мм	Конус Морзе	I, мм	L, мм
1293168	—	13,70	KM1	108,0	189,0
1261778	2301-3011	13,75	KM1	108,0	189,0
1168894	2301-0196	13,80	KM1	108,0	189,0
1181222	2301-0046	14,00	KM1	108,0	189,0
1258362	2301-0047	14,25	KM2	114,0	212,0
1258363	2301-0048	14,50	KM2	114,0	212,0
1293169	2301-0197	14,75	KM2	114,0	212,0
1181223	2301-0050	15,00	KM2	114,0	212,0
1418784	—	15,10	KM2	114,0	212,0
1293170	2301-0051	15,25	KM2	120,0	218,0
1293171	2301-0052	15,40	KM2	120,0	218,0
1293172	2301-0053	15,50	KM2	120,0	218,0
1293173	2301-0198	15,75	KM2	120,0	218,0
1258364	2301-0054	16,00	KM2	120,0	218,0
1293174	2301-0055	16,25	KM2	125,0	223,0
1168960	2301-0199	16,75	KM2	125,0	223,0
1258365	2301-0057	17,00	KM2	125,0	223,0
1293175	2301-0058	17,25	KM2	130,0	228,0
1267699	2301-0060	17,50	KM2	130,0	228,0
1293176	2301-0200	17,75	KM2	130,0	228,0
1252613	2301-0061	18,00	KM2	130,0	228,0
1293177	2301-0062	18,25	KM2	135,0	233,0
1258366	2301-0063	18,50	KM2	135,0	233,0
1293178	2301-0064	18,75	KM2	135,0	233,0
1181224	2301-0065	19,00	KM2	135,0	233,0
1293179	2301-0066	19,25	KM2	140,0	238,0
1169031	2301-0067	19,40	KM2	140,0	238,0
1169036	2301-0068	19,50	KM2	140,0	238,0
1258367	2301-0201	19,75	KM2	140,0	238,0
1181225	2301-0069	20,00	KM2	140,0	238,0
1258368	2301-0202	20,25	KM2	145,0	243,0
1258369	2301-0070	20,50	KM2	145,0	243,0
1258370	2301-0071	20,75	KM2	145,0	243,0
1252614	2301-0073	21,00	KM2	145,0	243,0
1293180	2301-0074	21,25	KM2	150,0	248,0
1258371	2301-0075	21,50	KM2	150,0	248,0
1293181	2301-3034	21,75	KM2	150,0	248,0
1258372	2301-0076	22,00	KM2	150,0	248,0
1293182	2301-0203	22,25	KM2	150,0	248,0

Артикул	Обозначение по ГОСТ	D, мм	Конус Морзе	I, мм	L, мм
1258373	2301-0077	22,50	KM2	155,0	253,0
1293183	2301-0078	22,75	KM2	155,0	253,0
1258374	2301-0079	23,00	KM2	155,0	253,0
1293184	2301-0080	23,25	KM3	155,0	276,0
1293185	2301-0081	23,50	KM3	155,0	276,0
1293186	2301-0204	23,75	KM3	160,0	281,0
1258375	2301-0083	24,00	KM3	160,0	281,0
1293187	2301-0084	24,25	KM3	160,0	281,0
1293188	2301-0085	24,50	KM3	160,0	281,0
1293189	2301-0086	24,75	KM3	160,0	281,0
1252615	2301-0087	25,00	KM3	160,0	281,0
1252616	2301-0088	25,50	KM3	165,0	286,0
1293190	2301-0206	25,75	KM3	165,0	286,0
1258376	2301-0089	26,00	KM3	165,0	286,0
1293191	2301-0090	26,25	KM3	165,0	286,0
1293192	2301-0095	27,25	KM3	170,0	291,0
1252617	2301-0098	28,00	KM3	170,0	291,0
1293193	2301-0209	28,25	KM3	175,0	296,0
1267700	2301-0099	28,50	KM3	175,0	296,0
1293194	2301-0210	28,75	KM3	175,0	296,0
1293195	2301-0101	29,25	KM3	175,0	296,0
1293196	2301-3048	29,75	KM3	175,0	296,0
1252618	2301-0106	30,00	KM3	175,0	296,0
1293197	2301-0108	30,50	KM3	180,0	301,0
1267701	2301-0109	31,00	KM3	180,0	301,0
1267702	2301-0111	31,50	KM3	180,0	301,0
1293198	2301-0112	31,75	KM3	185,0	306,0
1252619	2301-0113	32,00	KM4	185,0	334,0
1293199	2301-0115	32,50	KM4	185,0	334,0
1293200	2301-0117	33,00	KM4	185,0	334,0
1258377	2301-0214	33,25	KM4	185,0	334,0
1293203	2301-0118	33,50	KM4	185,0	334,0
1293204	2301-0119	34,00	KM4	190,0	339,0

Артикул	Обозначение по ГОСТ	D, мм	Конус Морзе	I, мм	L, мм
1293205	2301-0120	34,50	KM4	190,0	339,0
1227844	2301-0122	35,00	KM4	190,0	339,0
1293206	2301-0123	35,50	KM4	190,0	339,0
1293207	2301-0128	37,00	KM4	195,0	344,0
1293208	2301-0130	37,50	KM4	195,0	344,0
1293209	2301-0132	38,00	KM4	200,0	349,0
1293210	2301-0135	39,00	KM4	200,0	349,0
1169407	2301-0136	39,50	KM4	200,0	349,0
1181226	2301-0137	40,00	KM4	205,0	354,0
1293211	2301-0139	40,50	KM4	205,0	354,0
1293212	2301-0141	41,00	KM4	205,0	354,0
1293213	2301-0220	41,25	KM4	205,0	354,0
1325801	2301-0142	41,50	KM4	205,0	354,0
1293214	2301-0144	42,00	KM4	205,0	354,0
1293215	2301-0221	42,50	KM4	205,0	354,0
1258378	2301-0146	43,00	KM4	210,0	359,0
1293216	2301-0147	43,50	KM4	210,0	359,0
1293217	2301-0149	44,00	KM4	210,0	359,0
1252620	2301-0150	44,50	KM4	210,0	359,0
1258379	2301-0153	45,00	KM4	210,0	359,0
1169454	2301-0158	47,00	KM4	215,0	364,0
1169458	2301-0159	47,50	KM4	215,0	364,0
1293218	2301-0164	49,00	KM4	220,0	369,0
1293219	2301-0165	49,50	KM4	220,0	369,0
1181227	2301-0166	50,00	KM4	220,0	369,0
1293220	2301-0170	52,00	KM5	225,0	412,0
1293221	2301-0172	54,00	KM5	230,0	417,0
1293222	2301-0173	55,00	KM5	230,0	417,0
1293224	2301-0175	57,00	KM5	235,0	422,0
1293225	2301-0176	58,00	KM5	235,0	422,0
1293226	2301-0177	60,00	KM5	240,0	427,0
1258380	2301-0181	65,00	KM5	245,0	432,0

Свёрла спиральные с коническим хвостовиком. Средняя серия. Правые

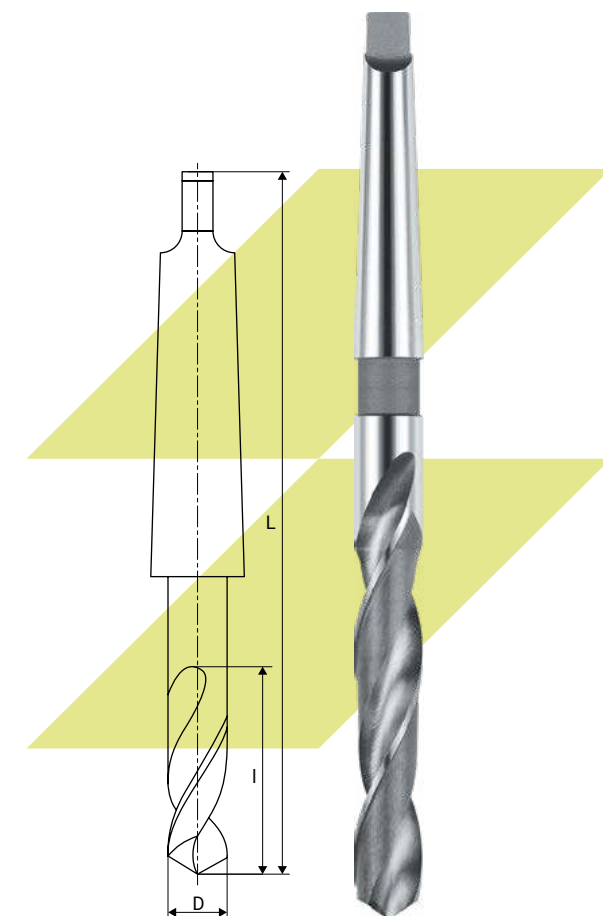
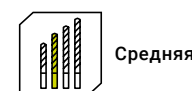
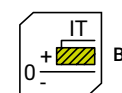
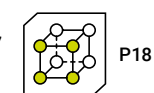

Артикул	Обозначение по ГОСТ	D, мм	Конус Морзе	I, мм	L, мм
1518099	2301-3555	6,00	KM1	57,0	138,0
1518100	—	6,70	KM1	63,0	144,0
1518101	2301-0189	6,80	KM1	69,0	150,0
1518102	2301-0007	7,00	KM1	69,0	150,0
1168708	2301-0014	7,80	KM1	75,0	156,0
1518103	2301-0015	8,00	KM1	75,0	156,0
1518104	—	8,50	KM1	75,0	156,0
1518105	2301-0023	9,00	KM1	81,0	162,0
1518106	2301-3576	9,50	KM1	81,0	162,0
1345788	—	9,70	KM1	87,0	168,0
1518107	2301-0028	10,00	KM1	87,0	168,0
1378461	2301-3579	10,20	KM1	87,0	168,0
1518108	2301-0032	10,50	KM1	87,0	168,0
1343063	2301-3583	11,00	KM1	94,0	175,0
1343064	2301-3587	12,00	KM1	101,0	182,0
1343065	2301-3592	13,00	KM1	101,0	182,0
1518109	2301-0043	13,20	KM1	101,0	182,0
1518110	2301-0044	13,50	KM1	108,0	189,0
1168892	2301-0196	13,80	KM1	108,0	189,0
1343066	2301-3597	14,00	KM1	108,0	189,0
1518111	2301-0047	14,25	KM2	114,0	212,0
1378462	2301-3599	14,50	KM2	114,0	212,0
1518112	2301-0197	14,75	KM2	114,0	212,0
1343067	2301-3602	15,00	KM2	114,0	212,0
1518113	2301-0051	15,25	KM2	120,0	218,0
1518114	2301-0198	15,75	KM2	120,0	218,0
1343068	2301-3607	16,00	KM2	120,0	218,0
1168953	2301-0056	16,50	KM2	125,0	223,0
1168958	2301-0199	16,75	KM2	125,0	223,0
1343069	2301-3612	17,00	KM2	125,0	223,0
1168975	2301-0059	17,40	KM2	130,0	228,0
1343070	2301-3615	17,50	KM2	130,0	228,0
1343071	2301-3617	18,00	KM2	130,0	228,0
1168995	2301-0062	18,25	KM2	135,0	233,0

Артикул	Обозначение по ГОСТ	D, мм	Конус Морзе	I, мм	L, мм
1343072	2301-3619	18,50	KM2	135,0	233,0
1169006	2301-0064	18,75	KM2	135,0	233,0
1378463	2301-3622	19,00	KM2	135,0	233,0
1169022	2301-0066	19,25	KM2	140,0	238,0
1169029	2301-0067	19,40	KM2	140,0	238,0
1169033	2301-0068	19,50	KM2	140,0	238,0
1237614	—	19,60	KM2	140,0	238,0
1343073	2301-3627	20,00	KM2	140,0	238,0
1343074	2301-3629	20,50	KM2	145,0	243,0
1378464	2301-3633	21,00	KM2	145,0	243,0
1169075	2301-0075	21,50	KM2	150,0	248,0
1343075	2301-3637	22,00	KM2	150,0	248,0
1378465	2301-3639	22,50	KM2	155,0	253,0
1169098	2301-0078	22,75	KM2	155,0	253,0
1169101	—	22,90	KM2	155,0	253,0
1343076	2301-3642	23,00	KM2	155,0	253,0
1169115	—	23,70	KM2	155,0	253,0
1169124	2301-0082	23,90	KM3	160,0	281,0
1343077	2301-3647	24,00	KM3	160,0	281,0
1169138	—	24,30	KM3	160,0	281,0
1169148	—	24,70	KM3	160,0	281,0
1169155	—	24,80	KM3	160,0	281,0
1343078	2301-3652	25,00	KM3	160,0	281,0
1343079	2301-3656	26,00	KM3	165,0	286,0
1169181	2301-0090	26,25	KM3	165,0	286,0

Артикул	Обозначение по ГОСТ	D, мм	Конус Морзе	I, мм	L, мм
1169205	2301-0095	27,25	KM3	170,0	291,0
1169222	2301-0098	28,00	KM3	170,0	291,0
1169240	—	28,60	KM3	175,0	296,0
1169243	—	28,70	KM3	155,0	270,0
1169245	2301-0210	28,75	KM3	175,0	296,0
1169250	2301-0100	29,00	KM3	175,0	296,0
1169258	2301-0101	29,25	KM3	175,0	296,0
1169288	2301-0211	30,75	KM3	180,0	301,0
1169295	2301-0110	31,25	KM3	180,0	301,0
1169298	—	31,40	KM3	180,0	301,0
1169301	2301-0111	31,50	KM3	180,0	301,0
1169317	2301-0115	32,50	KM4	185,0	334,0
1169321	—	32,90	KM4	185,0	334,0
1169322	2301-0117	33,00	KM4	185,0	334,0
1169324	2301-0214	33,25	KM4	185,0	334,0
1169334	2301-0119	34,00	KM4	190,0	339,0
1169340	2301-0120	34,50	KM4	190,0	339,0
1169356	—	35,90	KM4	195,0	344,0
1169358	2301-0125	36,00	KM4	195,0	344,0
1265637	2301-0217	36,25	KM4	195,0	344,0
1169365	2301-0126	36,50	KM4	195,0	344,0
1169370	—	36,90	KM4	195,0	344,0
1169374	2301-0128	37,00	KM4	195,0	344,0
1169379	2301-0130	37,50	KM4	195,0	344,0
1169384	2301-0132	38,00	KM4	200,0	349,0

Свёрла спиральные с коническим хвостовиком. Средняя серия. Правые

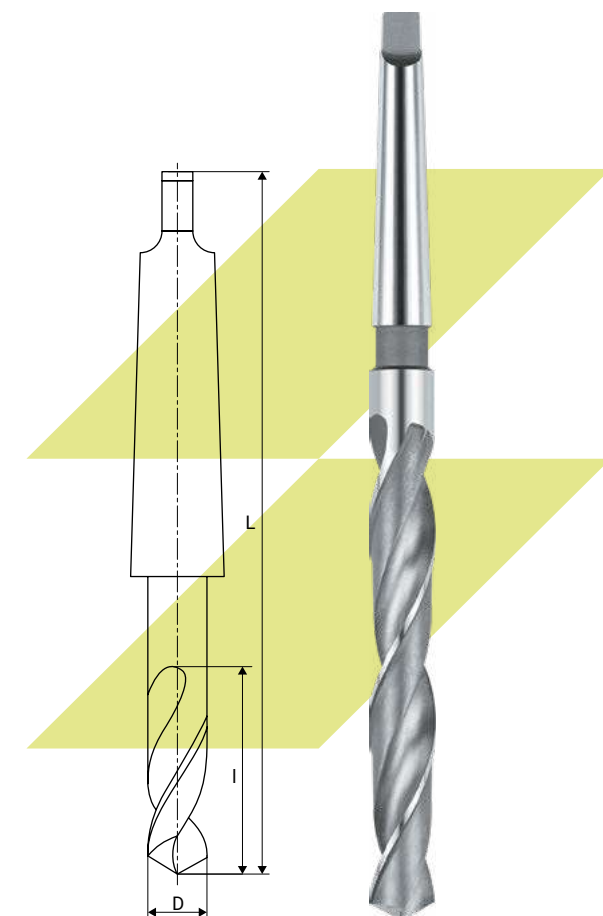
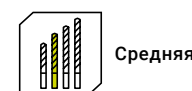
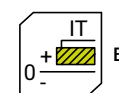
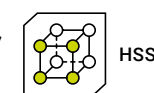
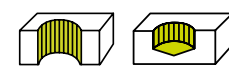

Артикул	Обозначение по ГОСТ	D, мм	Конус Морзе	I, мм	L, мм
1418667	2301-3555	6,00	KM1	57,0	138,0
1326148	—	6,70	KM1	63,0	144,0
1326149	2301-0189	6,80	KM1	69,0	150,0
1326150	2301-0007	7,00	KM1	69,0	150,0
1326151	2301-0015	8,00	KM1	75,0	156,0
1326152	2301-0020	8,50	KM1	75,0	156,0
1326153	2301-0023	9,00	KM1	81,0	162,0
1326154	2301-0028	10,00	KM1	87,0	168,0
1326155	—	10,10	KM1	87,0	168,0
1326156	2301-0030	10,20	KM1	87,0	168,0
1326157	—	10,30	KM1	87,0	168,0
1326158	2301-0032	10,50	KM1	87,0	168,0
1326159	2301-0034	11,00	KM1	94,0	175,0
1326160	2301-0039	12,00	KM1	101,0	182,0
1326161	2301-0194	12,20	KM1	101,0	182,0
1326162	2301-0040	12,50	KM1	101,0	182,0
1326163	2301-0042	13,00	KM1	101,0	182,0
1582637	2301-0043	13,20	KM1	101,0	182,0
1326164	2301-0046	14,00	KM1	108,0	189,0
1326165	2301-0047	14,25	KM2	114,0	212,0
1326166	2301-0048	14,50	KM2	114,0	212,0
1326167	2301-0197	14,75	KM2	114,0	212,0
1326168	2301-0050	15,00	KM2	114,0	212,0
1326169	2301-0051	15,25	KM2	120,0	218,0
1326170	2301-0053	15,50	KM2	120,0	218,0
1326171	2301-0198	15,75	KM2	120,0	218,0
1326172	2301-0054	16,00	KM2	120,0	218,0
1326173	2301-0055	16,25	KM2	125,0	223,0
1326174	2301-0056	16,50	KM2	125,0	223,0
1326175	2301-0199	16,75	KM2	125,0	223,0
1326176	2301-0057	17,00	KM2	125,0	223,0
1326177	2301-0058	17,25	KM2	130,0	228,0
1326178	2301-0060	17,50	KM2	130,0	228,0
1326179	2301-0200	17,75	KM2	130,0	228,0

Артикул	Обозначение по ГОСТ	D, мм	Конус Морзе	I, мм	L, мм
1326180	2301-0061	18,00	KM2	130,0	228,0
1326181	2301-0062	18,25	KM2	135,0	233,0
1326182	2301-0063	18,50	KM2	135,0	233,0
1326183	2301-0064	18,75	KM2	135,0	233,0
1326184	2301-0065	19,00	KM2	135,0	233,0
1326185	2301-0066	19,25	KM2	140,0	238,0
1326186	2301-0068	19,50	KM2	140,0	238,0
1326187	2301-0201	19,75	KM2	140,0	238,0
1326188	2301-0069	20,00	KM2	140,0	238,0
1326189	2301-0202	20,25	KM2	145,0	243,0
1326190	2301-0070	20,50	KM2	145,0	243,0
1326191	2301-0071	20,75	KM2	145,0	243,0
1326192	2301-0073	21,00	KM2	145,0	243,0
1326193	2301-0074	21,25	KM2	150,0	248,0
1326194	2301-0075	21,50	KM2	150,0	248,0
1326195	2301-3034	21,75	KM2	150,0	248,0
1326196	2301-0076	22,00	KM2	150,0	248,0
1326197	2301-0203	22,25	KM2	150,0	248,0
1326198	2301-0077	22,50	KM2	155,0	253,0
1326199	2301-0078	22,75	KM2	155,0	253,0
1169105	2301-0079	23,00	KM2	155,0	253,0
1169131	2301-0083	24,00	KM3	160,0	281,0
1265732	2301-0084	24,25	KM3	160,0	281,0
1169144	2301-0085	24,50	KM3	160,0	281,0
1518189	2301-0086	24,75	KM3	160,0	281,0
1169161	2301-0087	25,00	KM3	160,0	281,0
1169164	2301-0205	25,25	KM3	165,0	286,0
1518191	2301-0088	25,50	KM3	165,0	286,0
1169179	2301-0089	26,00	KM3	165,0	286,0
1441451	2301-0092	26,50	KM3	165,0	286,0
1441452	2301-0207	26,75	KM3	170,0	291,0
1169204	2301-0094	27,00	KM3	170,0	291,0
1441453	2301-0095	27,25	KM3	170,0	291,0
1417547	2301-0098	28,00	KM3	170,0	291,0
1583222	2301-0099	28,50	KM3	175,0	296,0
1289660	2301-0100	29,00	KM3	175,0	296,0
1335548	2301-0103	29,50	KM3	175,0	296,0
1441455	2301-3048	29,75	KM3	175,0	296,0
1169279	2301-0106	30,00	KM3	175,0	296,0

Артикул	Обозначение по ГОСТ	D, мм	Конус Морзе	I, мм	L, мм
1169281	2301-0107	30,25	KM3	180,0	301,0
1169285	2301-0108	30,50	KM3	180,0	301,0
1417549	2301-0109	31,00	KM3	180,0	301,0
1417551	2301-0111	31,50	KM3	180,0	301,0
1272043	2301-0112	31,75	KM3	185,0	306,0
1169313	2301-0113	32,00	KM4	185,0	334,0
1441458	2301-0213	32,25	KM4	185,0	334,0
1441459	2301-0115	32,50	KM4	185,0	334,0
1441460	—	32,75	KM4	185,0	334,0
1335549	2301-0117	33,00	KM4	185,0	334,0
1583223	2301-0118	33,50	KM4	185,0	334,0
1335550	2301-0119	34,00	KM4	190,0	339,0
1441462	2301-0122	35,00	KM4	190,0	339,0
1441463	2301-0215	35,25	KM4	190,0	339,0
1583224	2301-0123	35,50	KM4	190,0	339,0
1518192	2301-0125	36,00	KM4	195,0	344,0
1441465	2301-0217	36,25	KM4	190,0	339,0
1583225	2301-0130	37,50	KM4	195,0	344,0
1417553	2301-0132	38,00	KM4	200,0	349,0
1583226	2301-0218	38,25	KM4	200,0	349,0
1416469	2301-0135	39,00	KM4	200,0	349,0
1169417	2301-0137	40,00	KM4	200,0	349,0
1441467	2301-0139	40,50	KM4	205,0	354,0
1417554	2301-0141	41,00	KM4	205,0	354,0
1441469	2301-0220	41,25	KM4	205,0	354,0
1289662	2301-0144	42,00	KM4	205,0	354,0
1418599	2301-0221	42,50	KM4	205,0	354,0
1289664	2301-0146	43,00	KM4	210,0	359,0
1441471	2301-0147	43,50	KM4	210,0	359,0
1441473	2301-0149	44,00	KM4	210,0	359,0
1169442	2301-0153	45,00	KM4	210,0	359,0
1441475	2301-0223	45,25	KM4	215,0	364,0
1518193	2301-0224	45,50	KM4	215,0	364,0
1169449	2301-0154	46,00	KM4	215,0	364,0
1441476	2301-0155	46,50	KM4	215,0	364,0
1169455	2301-0158	47,00	KM4	215,0	364,0
1418651	2301-0161	48,00	KM4	215,0	364,0
1417557	2301-0164	49,00	KM4	220,0	369,0
1417559	2301-0165	49,50	KM4	220,0	369,0

Артикул	Обозначение по ГОСТ	D, мм	Конус Морзе	I, мм	L, мм
1169477	2301-0166	50,00	KM4	220,0	369,0
1417560	2301-0167	50,50	KM4	225,0	374,0
1276293	2301-0168	51,00	KM5	225,0	412,0
1424811	2301-0169	51,50	KM5	225,0	412,0
1260506	2301-0170	52,00	KM5	225,0	412,0
1289667	2301-0171	53,00	KM5	225,0	412,0
1289669	2301-0172	54,00	KM5	230,0	417,0
1261581	2301-0173	55,00	KM5	230,0	417,0
1169500	2301-0174	56,00	KM5	230,0	417,0
1169505	2301-0175	57,00	KM5	235,0	422,0
1169509	2301-0176	58,00	KM5	235,0	422,0
1169512	2301-3126	59,00	KM5	235,0	422,0
1169516	2301-0177	60,00	KM5	240,0	422,0
1169518	2301-0178	61,00	KM5	240,0	427,0
1169520	2301-0179	62,00	KM5	240,0	427,0
1169524	2301-0180	63,00	KM5	240,0	427,0
1169527	2301-3101	64,00	KM5	245,0	432,0
1169531	2301-0181	65,00	KM5	245,0	432,0
1169533	2301-3104	66,00	KM5	245,0	432,0
1169535	2301-3106	67,00	KM5	245,0	432,0
1169538	2301-0182	68,00	KM5	250,0	437,0
1169540	2301-3109	69,00	KM5	250,0	437,0
1169543	2301-0183	70,00	KM5	250,0	437,0
1169545	2301-3113	71,00	KM5	250,0	437,0
1169548	2301-0185	72,00	KM5	255,0	442,0
1169550	2301-3116	73,00	KM5	255,0	442,0
1169552	2301-3118	74,00	KM5	255,0	442,0

Артикул	Обозначение по ГОСТ	D, мм	Конус Морзе	I, мм	L, мм
1169556	2301-0186	75,00	KM5	255,0	442,0
1169558	2301-3122	76,00	KM5	260,0	447,0
1169560	2301-3124	77,00	KM6	260,0	514,0
1169565	2301-0187	78,00	KM6	260,0	514,0
1169567	2301-3125	79,00	KM6	260,0	514,0
1169571	2301-0188	80,00	KM6	260,0	514,0
1173954	—	81,00	KM6	265,0	519,0
1173955	—	82,00	KM6	265,0	519,0
1173956	—	83,00	KM6	265,0	519,0
1173957	—	84,00	KM6	265,0	519,0
1173958	—	85,00	KM6	265,0	519,0
1173959	—	86,00	KM6	270,0	524,0
1173960	—	87,00	KM6	270,0	524,0
1173961	—	88,00	KM6	270,0	524,0
1173962	—	89,00	KM6	270,0	524,0
1169572	—	90,00	KM6	270,0	524,0
1173963	—	91,00	KM6	275,0	529,0
1173964	—	92,00	KM6	275,0	529,0
1173965	—	93,00	KM6	275,0	529,0
1173966	—	94,00	KM6	275,0	529,0
1173967	—	95,00	KM6	275,0	529,0
1173968	—	96,00	KM6	280,0	534,0
1173969	—	97,00	KM6	280,0	534,0
1173970	—	98,00	KM6	280,0	534,0
1173971	—	99,00	KM6	280,0	534,0
1169573	—	100,00	KM6	280,0	534,0

Свёрла спиральные с коническим хвостовиком. Длинная серия. Правые

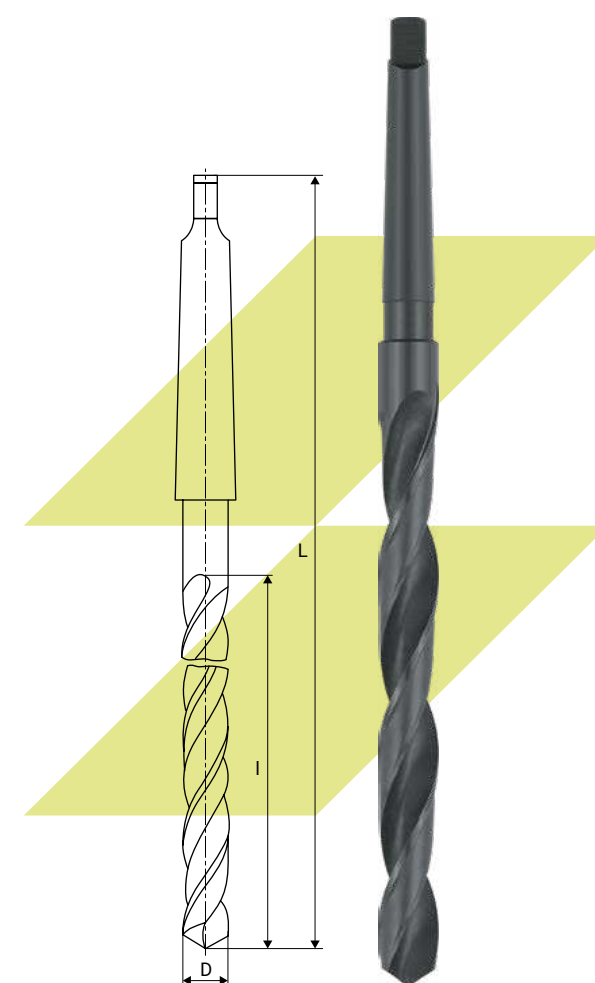
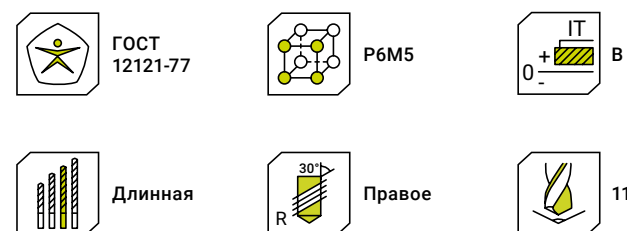

Артикул	Обозначение по ГОСТ	D, мм	Конус Морзе	I, мм	L, мм
1169575	2301-3517	5,00	KM1	74,0	155,0
1173972	2301-3519	5,20	KM1	74,0	155,0
1173973	2301-3523	5,50	KM1	80,0	161,0
1173974	2301-3526	5,80	KM1	80,0	161,0
1169577	2301-3351	6,00	KM1	80,0	161,0
1173975	2301-3352	6,10	KM1	83,0	165,0
1169579	2301-3353	6,20	KM1	86,0	167,0
1169581	2301-3353	6,30	KM1	83,0	165,0
1177530	2301-3355	6,40	KM1	83,0	165,0
1169583	2301-3356	6,50	KM1	86,0	167,0
1177531	2301-3357	6,60	KM1	83,0	165,0
1169584	2301-3358	6,70	KM1	86,0	167,0
1335527	2301-3359	6,80	KM1	93,0	174,0
1177532	2301-3361	6,90	KM1	90,0	170,0
1169587	2301-3362	7,00	KM1	93,0	174,0
1177533	2301-3363	7,10	KM1	90,0	170,0
1177534	2301-3364	7,20	KM1	90,0	170,0
1177535	2301-3365	7,30	KM1	90,0	170,0
1177536	2301-3363	7,40	KM1	90,0	170,0
1169590	2301-3367	7,50	KM1	93,0	174,0
1169591	2301-3368	7,60	KM1	100,0	181,0
1173976	2301-3369	7,70	KM1	100,0	181,0
1169593	2301-3371	7,80	KM1	100,0	181,0
1177537	2301-3372	7,90	KM1	100,0	181,0
1169596	2301-3373	8,00	KM1	100,0	181,0
1169598	2301-3374	8,10	KM1	100,0	181,0
1169601	2301-3175	8,20	KM1	100,0	181,0
1169603	2301-3176	8,30	KM1	100,0	181,0
1169605	2301-3177	8,40	KM1	100,0	181,0
1169608	2301-3178	8,50	KM1	100,0	181,0
1169611	2301-3381	8,70	KM1	107,0	188,0
1169612	2301-3382	8,80	KM1	107,0	188,0
1169615	2301-3384	9,00	KM1	107,0	188,0
1177538	2301-3385	9,10	KM1	107,0	188,0

Артикул	Обозначение по ГОСТ	D, мм	Конус Морзе	I, мм	L, мм
1169619	2301-3386	9,20	KM1	107,0	188,0
1177539	2301-3387	9,30	KM1	107,0	188,0
1177540	2301-3388	9,40	KM1	107,0	188,0
1169621	2301-3389	9,50	KM1	107,0	188,0
1177541	2301-3391	9,60	KM1	116,0	197,0
1179279	2301-3392	9,70	KM1	116,0	197,0
1169625	2301-3393	9,80	KM1	116,0	197,0
1177542	2301-3394	9,90	KM1	116,0	197,0
1169628	2301-3395	10,00	KM1	116,0	197,0
1169631	2301-3396	10,10	KM1	116,0	197,0
1169633	2301-3397	10,20	KM1	116,0	197,0
1169634	2301-3198	10,30	KM1	116,0	197,0
1177543	2301-3199	10,40	KM1	116,0	197,0
1169636	2301-3401	10,50	KM1	116,0	197,0
1177544	2301-3402	10,60	KM1	116,0	197,0
1169638	2301-3403	10,70	KM1	116,0	197,0
1177545	2301-3405	10,90	KM1	125,0	206,0
1169643	2301-3406	11,00	KM1	125,0	206,0
1177546	2301-3407	11,10	KM1	125,0	206,0
1169644	2301-3408	11,20	KM1	125,0	206,0
1169646	2301-3409	11,30	KM1	125,0	206,0
1169648	2301-3411	11,40	KM1	125,0	206,0
1169649	2301-3412	11,50	KM1	125,0	206,0
1343087	2301-3414	11,70	KM1	125,0	206,0
1169654	2301-3415	11,80	KM1	125,0	206,0
1173977	2301-3416	11,90	KM1	134,0	215,0
1169657	2301-3417	12,00	KM1	134,0	215,0
1177547	2301-3418	12,10	KM1	134,0	215,0
1169660	2301-3419	12,20	KM1	134,0	215,0
1169662	2301-3421	12,30	KM1	134,0	215,0
1169664	2301-3422	12,40	KM1	134,0	215,0
1169667	2301-3423	12,50	KM1	134,0	215,0
1169668	2301-3424	12,60	KM1	134,0	215,0
1169671	2301-3425	12,70	KM1	134,0	215,0
1177548	2301-3426	12,80	KM1	134,0	215,0
1177549	2301-3427	12,90	KM1	134,0	215,0
1169673	2301-3428	13,00	KM1	134,0	215,0
1177550	2301-3429	13,10	KM1	134,0	215,0
1169675	2301-3431	13,20	KM1	134,0	215,0

Артикул	Обозначение по ГОСТ	D, мм	Конус Морзе	I, мм	L, мм
1177551	2301-3432	13,30	KM1	142,0	223,0
1177552	2301-3433	13,40	KM1	142,0	223,0
1169677	2301-3434	13,50	KM1	142,0	223,0
1169678	2301-3435	13,60	KM1	142,0	223,0
1177553	2301-3436	13,70	KM1	142,0	223,0
1169680	2301-3437	13,80	KM1	142,0	223,0
1177554	2301-3438	13,90	KM1	142,0	223,0
1169682	2301-3439	14,00	KM1	142,0	223,0
1169683	2301-3441	14,25	KM2	147,0	245,0
1169685	2301-3442	14,50	KM2	147,0	245,0
1169687	2301-3443	14,75	KM2	147,0	245,0
1169690	2301-3444	15,00	KM2	147,0	245,0
1169691	2301-3445	15,25	KM2	153,0	251,0
1169694	2301-3447	15,50	KM2	153,0	251,0
1169696	2301-3448	15,75	KM2	153,0	251,0
1169699	2301-3449	16,00	KM2	153,0	251,0
1169700	2301-3451	16,25	KM2	159,0	257,0
1169702	2301-3452	16,50	KM2	159,0	257,0
1169704	2301-3453	16,75	KM2	159,0	257,0
1169706	2301-3454	17,00	KM2	159,0	257,0
1169707	2301-3455	17,25	KM2	165,0	263,0
1169708	2301-3457	17,50	KM2	165,0	263,0
1169709	2301-3458	17,75	KM2	165,0	263,0
1169712	2301-3459	18,00	KM2	165,0	263,0
1169713	2301-3461	18,25	KM2	171,0	269,0
1479853	2301-3463	18,75	KM2	171,0	269,0
1425143	2301-3464	19,00	KM2	175,0	275,0
1377795	2301-3468	19,75	KM2	180,0	280,0
1287112	2301-3469	20,00	KM2	180,0	280,0
1425144	2301-3473	20,50	KM2	185,0	285,0
1177555	2301-3473	20,75	KM2	185,0	280,0
1220025	2301-3475	21,00	KM2	191,0	289,0
1169723	2301-3477	21,50	KM2	191,0	289,0
1169725	2301-3479	22,00	KM2	191,0	289,0
1425145	2301-3484	23,00	KM2	195,0	285,0
1425146	2301-3487	23,75	KM3	203,0	325,0
1479854	2301-3489	24,00	KM3	206,0	327,0
1177556	2301-3491	24,25	KM3	203,0	325,0
1169731	2301-3492	24,50	KM3	206,0	327,0

Артикул	Обозначение по ГОСТ	D, мм	Конус Морзе	I, мм	L, мм
1425147	2301-3493	24,75	KM3	203,0	325,0
1425148	2301-3494	25,00	KM3	203,0	325,0
1171100	2301-3496	25,50	KM3	214,0	335,0
1425149	2301-3497	25,75	KM3	214,0	335,0
1169737	2301-3505	27,50	KM3	222,0	343,0
1181228	2301-3507	28,00	KM3	222,0	343,0

Артикул	Обозначение по ГОСТ	D, мм	Конус Морзе	I, мм	L, мм
1169740	2301-3508	28,25	KM3	230,0	351,0
1177557	2301-3509	28,50	KM3	230,0	351,0
1284665	2301-3513	29,25	KM3	230,0	351,0
1177558	2301-3514	29,50	KM3	230,0	351,0
1177559	2301-3516	30,00	KM3	230,0	351,0
1425150	2301-3532	31,00	KM3	239,0	360,0

Свёрла спиральные с коническим хвостовиком. Удлиненные. Правые

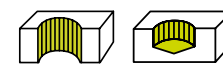

ГОСТ 2092-77



P6M5

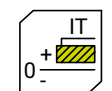

IT 0-1



Удлиненная



Правое



118°

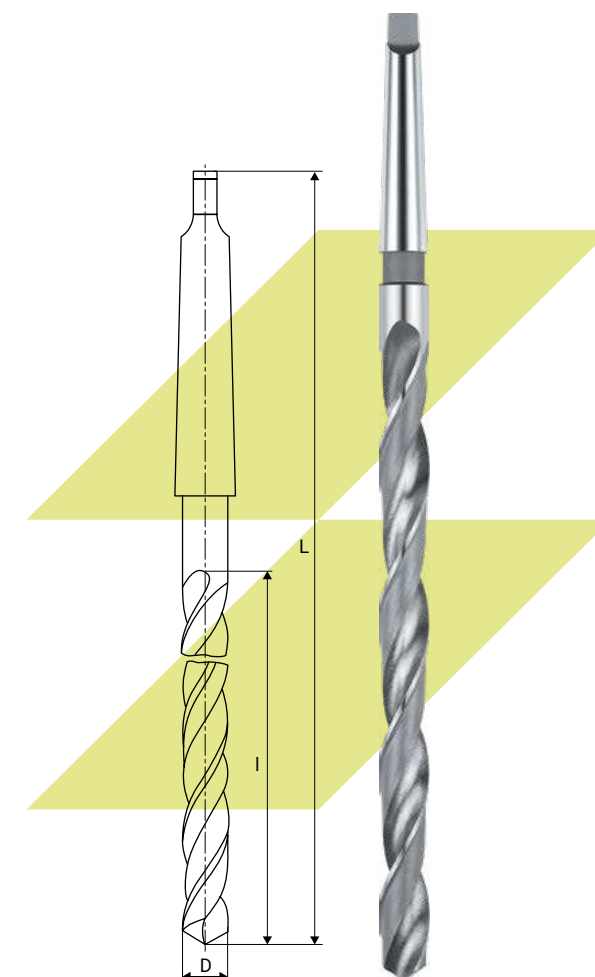

Артикул	Обозначение по ГОСТ	D, мм	Конус Морзе	I, мм	L, мм
1173978	—	5,00	KM1	145,0	225,0
1173979	—	5,20	KM1	145,0	225,0
1173980	—	5,50	KM1	145,0	225,0
1173981	—	5,80	KM1	145,0	225,0
1169752	2301-0371	6,00	KM1	145,0	225,0
1169754	2301-0372	6,10	KM1	145,0	225,0
1169757	2301-0373	6,20	KM1	145,0	225,0
1177564	2301-0374	6,30	KM1	150,0	230,0
1177565	2301-0477	6,40	KM1	150,0	230,0
1169760	2301-0375	6,50	KM1	150,0	230,0
1169762	2301-0478	6,60	KM1	150,0	230,0
1169764	2301-0376	6,70	KM1	150,0	230,0
1169766	2301-0479	6,80	KM1	150,0	230,0
1169768	2301-0480	6,90	KM1	150,0	230,0
1169769	2301-0377	7,00	KM1	155,0	235,0
1177566	2301-0378	7,10	KM1	155,0	235,0
1169772	2301-0379	7,20	KM1	155,0	235,0
1169774	2301-0380	7,30	KM1	155,0	235,0
1169776	2301-0381	7,50	KM1	155,0	235,0
1169778	2301-0382	7,60	KM1	155,0	235,0
1177567	2301-0383	7,70	KM1	155,0	235,0
1169780	2301-0384	7,80	KM1	155,0	235,0
1169781	2301-0481	7,90	KM1	155,0	235,0
1169785	2301-0385	8,00	KM1	160,0	240,0
1169787	2301-0386	8,10	KM1	160,0	240,0
1169789	2301-0387	8,20	KM1	160,0	240,0
1169791	2301-0388	8,30	KM1	160,0	240,0
1169795	2301-0390	8,50	KM1	160,0	240,0
1169797	2301-0482	8,60	KM1	160,0	240,0
1169799	2301-0391	8,70	KM1	160,0	240,0
1169801	2301-0483	8,80	KM1	160,0	240,0
1169803	2301-0392	8,90	KM1	160,0	240,0
1169806	2301-0393	9,00	KM1	165,0	245,0
1169807	2301-4159	9,10	KM1	165,0	245,0

Свёрла спиральные цельные твердосплавные. Укороченные. Правые

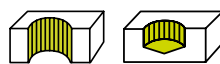

Артикул	Обозначение по ГОСТ	D, мм	d, мм	l, мм	L, мм
1170640	2300-3657	2,9	5,0	10,0	45,0
1170653	2300-3663	3,1	6,0	12,0	52,0
1269531	2300-3667	3,2	6,0	12,0	52,0
1269532	2300-3669	3,3	6,0	12,0	52,0
1170674	2300-3675	3,5	6,0	12,0	52,0
1170688	2300-3681	3,8	7,0	16,0	56,0
1584598	2300-3683	3,9	7,0	16,0	56,0
1240764	2300-3689	4,2	7,0	32,0	65,0
1584599	2300-3695	4,4	7,0	16,0	56,0
1170795	2300-3733	6,3	10,0	25,0	65,0
1242017	2300-3737	6,5	10,0	25,0	65,0

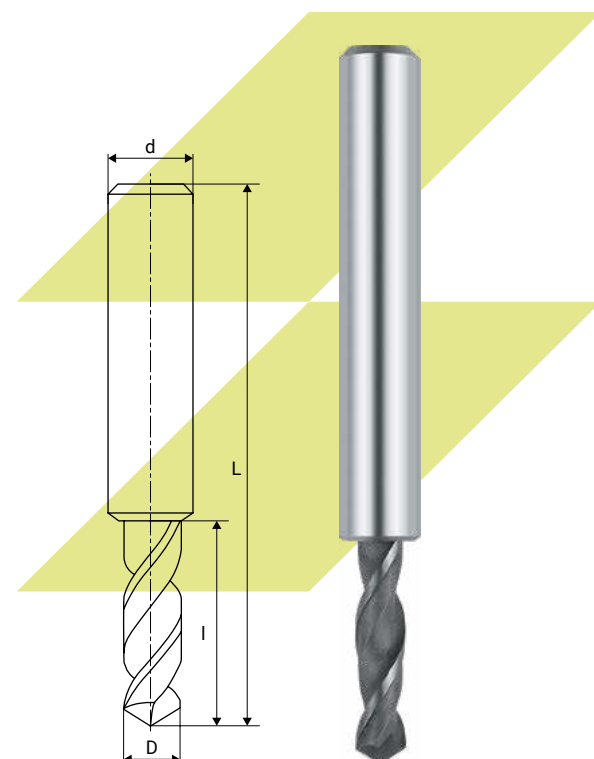

Свёрла спиральные цельные твердосплавные. Короткая серия. Правые

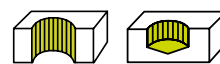

Артикул	Обозначение по ГОСТ	D, мм	d, мм	l, мм	L, мм
1276885	2300-3751	1,00	1,00	6,0	32,0
1276886	2300-3753	1,05	1,05	6,0	32,0
1276887	2300-3755	1,10	1,10	7,0	32,0
1276888	2300-3757	1,15	1,15	7,0	32,0
1276889	2300-3759	1,20	1,20	8,0	32,0
1276890	2300-3761	1,25	1,25	8,0	32,0
1276891	2300-3763	1,30	1,30	8,0	32,0
1276892	2300-3765	1,35	1,35	9,0	36,0
1276893	2300-3767	1,40	1,40	9,0	36,0
1276894	2300-3769	1,45	1,45	9,0	36,0
1284236	2300-3771	1,50	1,50	9,0	36,0
1276895	2300-3773	1,55	1,55	10,0	36,0
1284237	2300-3775	1,60	1,60	10,0	36,0
1276896	2300-3777	1,65	1,65	10,0	36,0
1276897	2300-3779	1,70	1,70	10,0	36,0
1276898	2300-3781	1,75	1,75	11,0	38,0
1284238	2300-3783	1,80	1,80	11,0	38,0
1276899	2300-3785	1,85	1,85	11,0	38,0
1284239	2300-3787	1,90	1,90	11,0	38,0
1276900	2300-3789	1,95	1,95	12,0	38,0
1284240	2300-3791	2,00	2,00	12,0	38,0
1284241	2300-3793	2,05	2,05	12,0	38,0
1284242	2300-3795	2,10	2,10	12,0	38,0
1276901	2300-3797	2,15	2,15	13,0	40,0
1284243	2300-3799	2,20	2,20	13,0	40,0
1276902	2300-3801	2,25	2,25	13,0	40,0
1276903	2300-3803	2,30	2,30	13,0	40,0
1276904	2300-3805	2,35	2,35	13,0	40,0
1284244	2300-3807	2,40	2,40	14,0	42,0
1276905	2300-3809	2,45	2,45	14,0	42,0
1284245	2300-3811	2,50	2,50	14,0	42,0
1276906	2300-3813	2,55	2,55	14,0	42,0
1284246	2300-3815	2,60	2,60	14,0	42,0
1276907	2300-3817	2,65	2,65	16,0	45,0

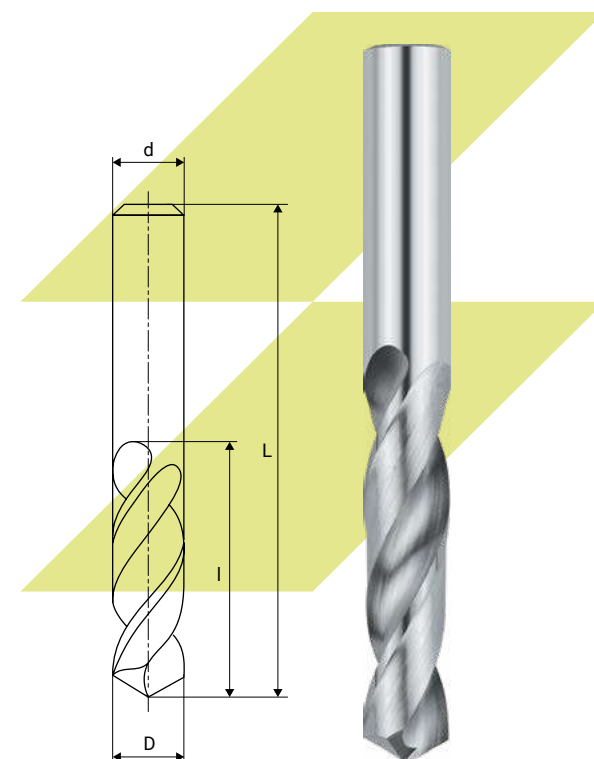

Артикул	Обозначение по ГОСТ	D, мм	d, мм	l, мм	L, мм
1284247	2300-3819	2,70	2,70	16,0	45,0
1276908	2300-3821	2,75	2,75	16,0	45,0
1276909	2300-3823	2,80	2,80	16,0	45,0
1276910	2300-3825	2,85	2,85	16,0	45,0
1284248	2300-3827	2,90	2,90	16,0	45,0
1276911	2300-3829	2,95	2,95	16,0	45,0
1284249	2300-3831	3,00	3,00	16,0	45,0
1284250	2300-3833	3,10	3,10	18,0	50,0
1276912	2300-3835	3,15	3,15	18,0	50,0
1284251	2300-3837	3,20	3,20	18,0	50,0
1284252	2300-3839	3,30	3,30	18,0	50,0
1276913	2300-3841	3,35	3,35	18,0	50,0
1284253	2300-3843	3,40	3,40	20,0	52,0
1284254	2300-3845	3,50	3,50	20,0	52,0
1276914	2300-3847	3,60	3,60	20,0	52,0
1276915	2300-3849	3,70	3,70	20,0	52,0
1276916	2300-3851	3,80	3,80	22,0	55,0
1276917	2300-3853	3,90	3,90	22,0	55,0
1284255	2300-3855	4,00	4,00	22,0	55,0
1284256	2300-3857	4,10	4,10	22,0	55,0
1284257	2300-3859	4,20	4,20	22,0	55,0
1276918	2300-3861	4,25	4,25	22,0	55,0
1284258	2300-3863	4,30	4,30	24,0	60,0
1284259	2300-3865	4,40	4,40	24,0	60,0
1284260	2300-3867	4,50	4,50	24,0	60,0
1276919	2300-3869	4,60	4,60	24,0	60,0
1284261	2300-3871	4,70	4,70	24,0	60,0
1284262	2300-3873	4,80	4,80	26,0	63,0
1284263	2300-3875	4,90	4,90	26,0	63,0
1284264	2300-3877	5,00	5,00	26,0	63,0
1284265	2300-3879	5,10	5,10	26,0	63,0
1284266	2300-3881	5,20	5,20	26,0	63,0
1276920	2300-3883	5,30	5,30	26,0	63,0
1276921	2300-3885	5,40	5,40	28,0	65,0
1284267	2300-3887	5,50	5,50	28,0	65,0
1284268	2300-3889	5,60	5,60	28,0	65,0
1276922	2300-3891	5,70	5,70	28,0	65,0
1284269	2300-3893	5,80	5,80	28,0	65,0
1284270	2300-3895	5,90	5,90	28,0	65,0

Артикул	Обозначение по ГОСТ	D, мм	d, мм	l, мм	L, мм
1284271	2300-3897	6,00	6,00	28,0	65,0
1276923	2300-3899	6,10	6,10	30,0	70,0
1284272	2300-3901	6,20	6,20	30,0	70,0
1276924	2300-3903	6,30	6,30	30,0	70,0
1276925	2300-3905	6,40	6,40	30,0	70,0
1276926	2300-3907	6,50	6,50	30,0	70,0
1284354	2300-3909	6,60	6,60	30,0	70,0
1284355	2300-3911	6,70	6,70	30,0	70,0
1284356	2300-3913	6,80	6,80	34,0	75,0
1284357	2300-3915	6,90	6,90	34,0	75,0
1284358	2300-3917	7,00	7,00	34,0	75,0
1276927	2300-3919	7,10	7,10	34,0	75,0
1276928	2300-3921	7,20	7,20	34,0	75,0
1276929	2300-3923	7,30	7,30	34,0	75,0
1276930	2300-3925	7,40	7,40	34,0	75,0
1276931	2300-3927	7,50	7,50	34,0	75,0
1276932	2300-3929	7,60	7,60	38,0	80,0
1276933	2300-3931	7,70	7,70	38,0	80,0
1276934	2300-3933	7,80	7,80	38,0	80,0
1284359	2300-3935	7,90	7,90	38,0	80,0
1284360	2300-3937	8,00	8,00	38,0	80,0
1276935	2300-3939	8,10	8,10	38,0	80,0
1276936	2300-3941	8,20	8,20	38,0	80,0
1276937	2300-3943	8,30	8,30	38,0	80,0
1276938	2300-3945	8,40	8,40	38,0	80,0
1284361	2300-3947	8,50	8,50	38,0	80,0
1276939	2300-3949	8,60	8,60	40,0	85,0
1276940	2300-3951	8,70	8,70	40,0	85,0
1276941	2300-3953	8,80	8,80	40,0	85,0
1276942	2300-3955	8,90	8,90	40,0	85,0
1284362	2300-3957	9,00	9,00	40,0	85,0
1276943	2300-3959	9,10	9,10	40,0	85,0
1276944	2300-3961	9,20	9,20	40,0	85,0
1276945	2300-3963	9,30	9,30	40,0	85,0
1276946	2300-3965	9,40	9,40	40,0	85,0
1276947	2300-3967	9,50	9,50	40,0	85,0
1276948	2300-3969	9,60	9,60	45,0	90,0
1276949	2300-3971	9,70	9,70	45,0	90,0
1276950	2300-3973	9,80	9,80	45,0	90,0

Артикул	Обозначение по ГОСТ	D, мм	d, мм	l, мм	L, мм
1276951	2300-3975	9,90	9,90	45,0	90,0
1284363	2300-3977	10,00	10,00	45,0	90,0
1276952	2300-3979	10,10	10,10	45,0	90,0
1284364	2300-3981	10,20	10,20	45,0	90,0
1276953	2300-3983	10,30	10,30	45,0	90,0
1276954	2300-3985	10,40	10,40	45,0	90,0
1276955	2300-3987	10,50	10,50	45,0	90,0
1276956	2300-3989	10,60	10,60	45,0	90,0
1276957	2300-3991	10,70	10,70	48,0	95,0
1276958	2300-3993	10,80	10,80	48,0	95,0
1276959	2300-3995	10,90	10,90	48,0	95,0
1284365	2300-3997	11,00	11,00	48,0	95,0
1276960	2300-3999	11,10	11,10	48,0	95,0

Артикул	Обозначение по ГОСТ	D, мм	d, мм	l, мм	L, мм
1276961	2300-2081	11,20	11,20	48,0	95,0
1276962	2300-2083	11,30	11,30	48,0	95,0
1276963	2300-2085	11,40	11,40	48,0	95,0
1276964	2300-2087	11,50	11,50	48,0	95,0
1276965	2300-2089	11,60	11,60	48,0	95,0
1276966	2300-2091	11,70	11,70	48,0	95,0
1276967	2300-2093	11,80	11,80	48,0	95,0
1276968	2300-2095	11,90	11,90	50,0	100,0
1284366	2300-2097	12,00	12,00	50,0	100,0
1377756	—	12,50	12,50	50,0	100,0
1377757	—	14,50	14,50	55,0	110,0
1377758	—	16,00	16,00	58,0	115,0
1377759	—	16,50	16,50	60,0	120,0

Свёрла спиральные цельные твердосплавные. Средняя серия. Правые

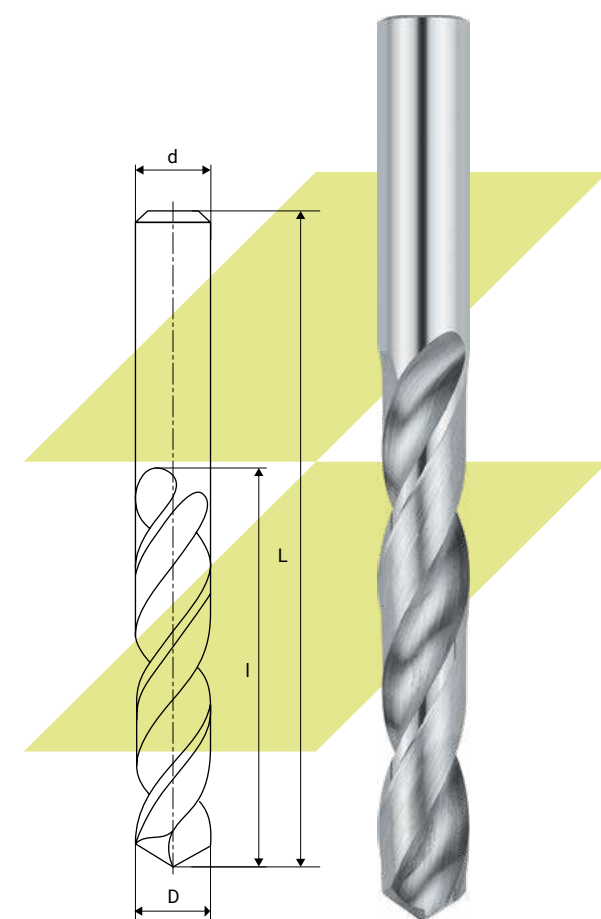

Артикул	Обозначение по ГОСТ	D, мм	d, мм	l, мм	L, мм
1260359	2309-0301	3,00	3,00	24,0	55,0
1258924	2309-0303	3,10	3,10	24,0	55,0
1276751	2309-0305	3,15	3,15	24,0	55,0
1276752	2309-0307	3,20	3,20	24,0	55,0
1276753	2309-0309	3,30	3,30	24,0	55,0
1276754	2309-0311	3,35	3,35	24,0	55,0
1276755	2309-0313	3,40	3,40	28,0	60,0
1258925	2309-0315	3,50	3,50	28,0	60,0
1276756	2309-0317	3,60	3,60	28,0	60,0
1276757	2309-0319	3,70	3,70	28,0	60,0
1276758	2309-0321	3,80	3,80	30,0	63,0
1276759	2309-0323	3,90	3,90	30,0	63,0
1258926	2309-0325	4,00	4,00	30,0	63,0
1276760	2309-0327	4,10	4,10	30,0	63,0
1276761	2309-0329	4,20	4,20	30,0	63,0
1276762	2309-0331	4,25	4,25	30,0	63,0
1276763	2309-0333	4,30	4,30	32,0	65,0
1276764	2309-0335	4,40	4,40	32,0	65,0
1258927	2309-0337	4,50	4,50	32,0	65,0
1276765	2309-0339	4,60	4,60	32,0	65,0
1276766	2309-0341	4,70	4,70	32,0	65,0
1276767	2309-0343	4,80	4,80	36,0	70,0
1276768	2309-0345	4,90	4,90	36,0	70,0
1258928	2309-0347	5,00	5,00	36,0	70,0
1276769	2309-0349	5,10	5,10	36,0	70,0
1276770	2309-0351	5,20	5,20	36,0	70,0
1276771	2309-0353	5,30	5,30	36,0	70,0
1276772	2309-0355	5,40	5,40	40,0	75,0
1258929	2309-0357	5,50	5,50	40,0	75,0
1276773	2309-0359	5,60	5,60	40,0	75,0
1276774	2309-0361	5,70	5,70	40,0	75,0
1276775	2309-0363	5,80	5,80	40,0	75,0
1276776	2309-0365	5,90	5,90	40,0	75,0
1258930	2309-0367	6,00	6,00	40,0	75,0

Артикул	Обозначение по ГОСТ	D, мм	d, мм	l, мм	L, мм
1276777	2309-0369	6,10	6,10	42,0	80,0
1276778	2309-0371	6,20	6,20	42,0	80,0
1276779	2309-0373	6,30	6,30	42,0	80,0
1276780	2309-0375	6,40	6,40	42,0	80,0
1276781	2309-0377	6,50	6,50	42,0	80,0
1276782	2309-0379	6,60	6,60	42,0	80,0
1276783	2309-0381	6,70	6,70	42,0	80,0
1276784	2309-0383	6,80	6,80	45,0	85,0
1276785	2309-0385	6,90	6,90	45,0	85,0
1260360	2309-0387	7,00	7,00	45,0	85,0
1276786	2309-0389	7,10	7,10	45,0	85,0
1276787	2309-0391	7,20	7,20	45,0	85,0
1276788	2309-0393	7,30	7,30	45,0	85,0
1276789	2309-0395	7,40	7,40	45,0	85,0
1276790	2309-0397	7,50	7,50	45,0	85,0
1276791	2309-0399	7,60	7,60	52,0	95,0
1276792	2309-0401	7,70	7,70	52,0	95,0
1276793	2309-0403	7,80	7,80	52,0	95,0
1276794	2309-0405	7,90	7,90	52,0	95,0
1260361	2309-0407	8,00	8,00	52,0	95,0
1276795	2309-0409	8,10	8,10	52,0	95,0
1276796	2309-0411	8,20	8,20	52,0	95,0
1276797	2309-0413	8,30	8,30	52,0	95,0
1276798	2309-0415	8,40	8,40	52,0	95,0
1276799	2309-0417	8,50	8,50	52,0	95,0
1276800	2309-0419	8,60	8,60	55,0	100,0
1276801	2309-0421	8,70	8,70	55,0	100,0
1276802	2309-0423	8,80	8,80	55,0	100,0
1276803	2309-0425	8,90	8,90	55,0	100,0
1260362	2309-0427	9,00	9,00	55,0	100,0
1276804	2309-0429	9,10	9,10	55,0	100,0

Артикул	Обозначение по ГОСТ	D, мм	d, мм	l, мм	L, мм
1276805	2309-0431	9,20	9,20	55,0	100,0
1276806	2309-0433	9,30	9,30	60,0	105,0
1276807	2309-0435	9,40	9,40	60,0	105,0
1276808	2309-0437	9,50	9,50	60,0	105,0
1276809	2309-0439	9,60	9,60	60,0	105,0
1276810	2309-0441	9,70	9,70	60,0	105,0
1276811	2309-0443	9,80	9,80	60,0	105,0
1276812	2309-0445	9,90	9,90	60,0	105,0
1260363	2309-0447	10,00	10,00	60,0	105,0
1276813	2309-0449	10,10	10,10	60,0	105,0
1276814	2309-0451	10,20	10,20	60,0	105,0
1276815	2309-0453	10,30	10,30	60,0	105,0
1276816	2309-0455	10,40	10,40	60,0	105,0
1276817	2309-0457	10,50	10,50	60,0	105,0
1276818	2309-0459	10,60	10,60	65,0	110,0
1276819	2309-0461	10,70	10,70	65,0	110,0
1276820	2309-0463	10,80	10,80	65,0	110,0
1276821	2309-0465	10,90	10,90	65,0	110,0
1260364	2309-0467	11,00	11,00	65,0	110,0
1276822	2309-0469	11,10	11,10	65,0	110,0
1276823	2309-0471	11,20	11,20	65,0	110,0
1276824	2309-0473	11,30	11,30	65,0	110,0
1276825	2309-0475	11,40	11,40	65,0	110,0
1276826	2309-0477	11,50	11,50	65,0	110,0
1276827	2309-0479	11,60	11,60	65,0	110,0
1276828	2309-0481	11,70	11,70	65,0	110,0
1276829	2309-0483	11,80	11,80	65,0	110,0
1276830	2309-0485	11,90	11,90	70,0	120,0
1260365	2309-0487	12,00	12,0	70,0	120,0
1260366	—	13,00	13,00	70,0	120,0
1260367	—	14,00	14,00	80,0	130,0

Свёрла спиральные цельные твердосплавные. DIN 338

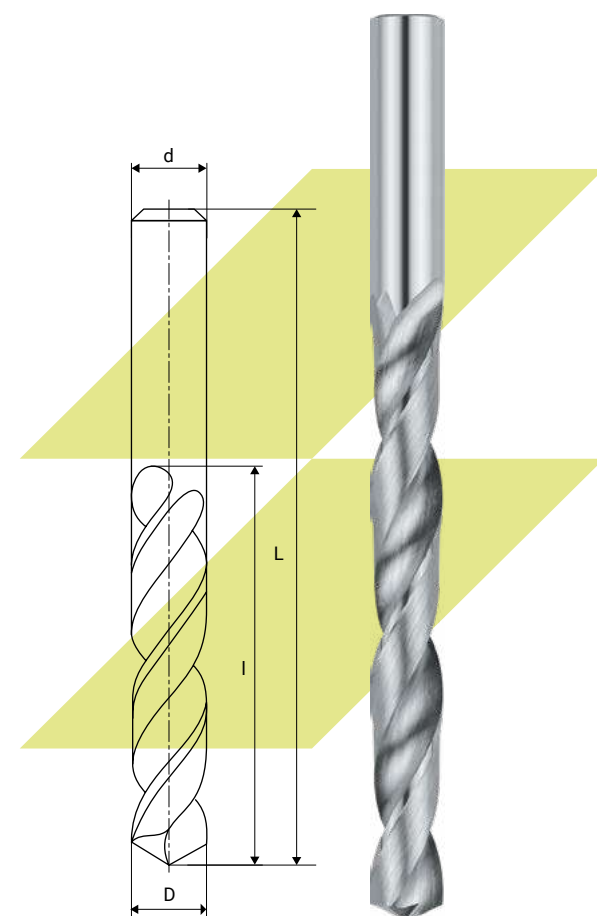
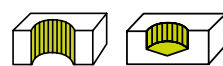

Артикул	D, мм	d, мм	l, мм	L, мм
1236386	1,00	1,00	12,0	34,0
1240715	1,08	1,08	14,0	36,0
1227022	1,20	1,20	16,0	38,0
1175912	1,50	1,50	18,0	40,0
1175913	1,60	1,60	20,0	43,0
1175914	1,80	1,80	22,0	46,0
1175915	1,90	1,90	22,0	46,0
1175916	2,00	2,00	24,0	49,0
1236387	2,10	2,10	24,0	49,0
1175917	2,20	2,20	27,0	53,0
1234911	2,40	2,40	30,0	57,0
1175918	2,50	2,50	30,0	57,0
1175919	2,60	2,60	30,0	57,0
1185755	2,70	2,70	33,0	61,0
1185756	2,80	2,80	33,0	61,0
1175920	2,90	2,90	33,0	61,0
1175921	3,00	3,00	33,0	61,0
1175922	3,10	3,10	36,0	65,0
1175923	3,20	3,20	36,0	65,0
1175924	3,30	3,30	36,0	65,0
1236388	3,40	3,40	39,0	70,0
1178559	3,50	3,50	39,0	70,0
1184280	3,60	3,60	39,0	70,0
1184281	3,70	3,70	39,0	70,0
1178560	3,80	3,80	43,0	75,0
1178561	3,90	3,90	43,0	75,0
1175925	4,00	4,00	43,0	75,0
1175926	4,10	4,10	43,0	75,0
1175927	4,20	4,20	43,0	75,0
1175928	4,30	4,30	47,0	80,0
1175929	4,50	4,50	47,0	80,0
1185757	4,60	4,60	47,0	80,0
1175930	4,70	4,70	47,0	80,0
1178562	4,80	4,80	52,0	86,0

Артикул	D, мм	d, мм	l, мм	L, мм
1178563	4,90	4,90	52,0	86,0
1175931	5,00	5,00	52,0	86,0
1175932	5,10	5,10	52,0	86,0
1175933	5,20	5,20	52,0	86,0
1184282	5,50	5,50	57,0	93,0
1185657	5,60	5,60	57,0	93,0
1185758	5,70	5,70	57,0	93,0
1175934	5,80	5,80	57,0	93,0
1175935	5,90	5,90	57,0	93,0
1175936	6,00	6,00	57,0	93,0
1378723	6,10	6,10	63,0	101,0
1175937	6,70	6,70	63,0	101,0
1175938	6,80	6,80	69,0	109,0
1178564	6,90	6,90	69,0	109,0

Артикул	D, мм	d, мм	l, мм	L, мм
1175939	7,00	7,00	69,0	109,0
1584939	7,70	7,70	75,0	117,0
1584940	7,80	7,80	75,0	117,0
1178565	7,90	7,90	75,0	117,0
1175940	8,00	8,00	75,0	117,0
1378724	8,10	8,10	75,0	117,0
1175941	8,50	8,50	75,0	117,0
1175942	9,00	9,00	81,0	125,0
1584942	9,50	9,50	81,0	125,0
1175943	10,00	10,00	87,0	133,0
1584943	10,20	10,20	87,0	133,0
1175944	11,00	11,00	94,0	142,0
1175945	12,00	12,00	101,0	151,0

Свёрла спиральные цельные твердосплавные с покрытием TiAlN. DIN 338

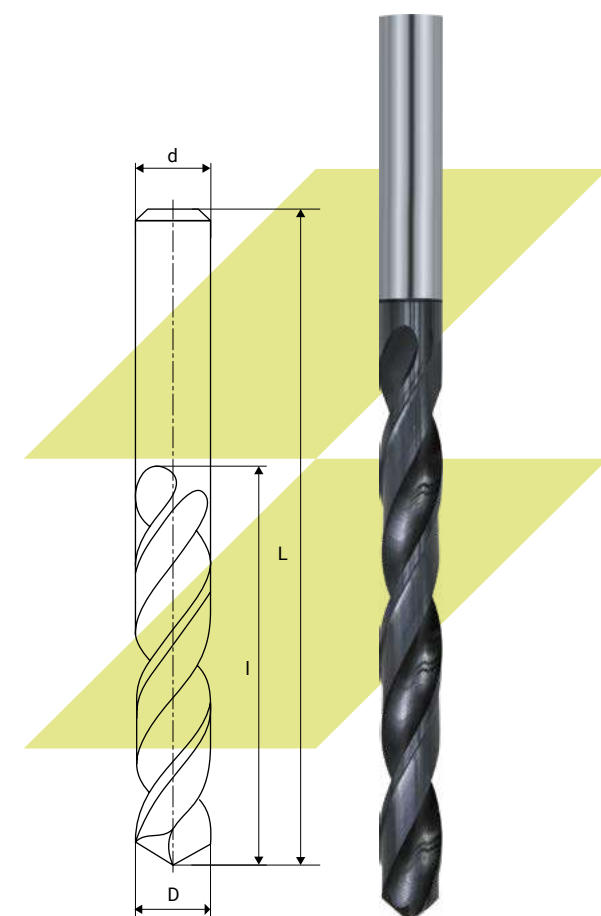

Артикул	D, мм	d, мм	I, мм	L, мм
1614806	1,05	1,05	12,0	34,0
1614807	1,10	1,10	14,0	36,0
1614808	1,15	1,15	14,0	36,0
1614809	1,25	1,25	16,0	38,0
1614810	1,30	1,30	16,0	38,0
1614811	1,35	1,35	18,0	40,0
1614812	1,40	1,40	18,0	40,0
1614813	1,55	1,55	20,0	43,0
1614814	1,65	1,65	20,0	43,0
1614815	1,70	1,70	20,0	43,0
1614816	1,75	1,75	22,0	46,0
1614817	1,85	1,85	22,0	46,0
1614818	1,95	1,95	24,0	49,0
1614819	2,05	2,05	24,0	49,0
1614820	2,15	2,15	27,0	53,0
1614821	2,25	2,25	27,0	53,0
1614822	2,30	2,30	27,0	53,0
1614823	2,35	2,35	27,0	53,0
1614824	2,55	2,55	30,0	57,0
1614825	2,65	2,65	30,0	57,0
1614826	2,75	2,75	33,0	61,0
1614827	2,85	2,85	33,0	61,0
1614828	3,15	3,15	36,0	65,0
1614829	3,35	3,35	36,0	65,0
1614830	4,40	4,40	47,0	80,0
1614831	5,30	5,30	52,0	86,0
1614832	5,40	5,40	57,0	93,0
1614833	6,20	6,20	63,0	101,0
1614834	6,30	6,30	63,0	101,0
1614835	6,40	6,40	63,0	101,0
1614836	6,50	6,50	63,0	101,0
1614837	6,60	6,60	63,0	101,0
1614838	7,10	7,10	69,0	109,0
1614839	7,20	7,20	69,0	109,0

Артикул	D, мм	d, мм	I, мм	L, мм
1614840	7,30	7,30	69,0	109,0
1614841	7,40	7,40	69,0	109,0
1614842	7,50	7,50	69,0	109,0
1614843	7,60	7,60	75,0	117,0
1614844	8,20	8,20	75,0	117,0
1614845	8,30	8,30	75,0	117,0
1614846	8,40	8,40	75,0	117,0
1614847	8,70	8,70	81,0	125,0
1614848	8,80	8,80	81,0	125,0
1614849	8,90	8,90	81,0	125,0
1614850	9,10	9,10	81,0	125,0
1614851	9,20	9,20	81,0	125,0
1614852	9,30	9,30	81,0	125,0
1614853	9,40	9,40	81,0	125,0
1614854	9,60	9,60	87,0	133,0
1614855	9,70	9,70	87,0	133,0
1614856	9,80	9,80	87,0	133,0
1614857	9,90	9,90	87,0	133,0
1614858	10,10	10,10	87,0	133,0
1614859	10,30	10,30	87,0	133,0
1614860	10,40	10,40	87,0	133,0
1614861	10,50	10,50	87,0	133,0
1614862	10,60	10,60	87,0	133,0
1614863	10,70	10,70	94,0	142,0
1614864	10,80	10,80	94,0	142,0
1614865	10,90	10,90	94,0	142,0
1614866	11,10	11,10	94,0	142,0
1614867	11,20	11,20	94,0	142,0
1614868	11,30	11,30	94,0	142,0
1614869	11,40	11,40	94,0	142,0
1614870	11,50	11,50	94,0	142,0
1614871	11,60	11,60	94,0	142,0
1614872	11,70	11,70	94,0	142,0

Артикул	D, мм	d, мм	I, мм	L, мм
1614873	11,80	11,80	94,0	142,0
1614874	11,90	11,90	101,0	151,0
1614875	12,10	12,10	101,0	151,0
1614876	12,20	12,20	101,0	151,0
1614877	12,30	12,30	101,0	151,0
1614878	12,40	12,40	101,0	151,0
1614879	12,50	12,50	101,0	151,0
1614880	12,60	12,60	101,0	151,0
1614881	12,70	12,70	101,0	151,0
1614882	12,80	12,80	101,0	151,0
1614883	12,90	12,90	101,0	151,0
1614884	13,00	13,00	101,0	151,0
1614885	13,10	13,10	101,0	151,0
1614886	13,20	13,20	101,0	151,0
1614887	13,30	13,30	108,0	160,0
1614888	13,40	13,40	108,0	160,0
1614889	13,50	13,50	108,0	160,0
1614890	13,60	13,60	108,0	160,0
1614891	13,70	13,70	108,0	160,0
1614892	13,80	13,80	108,0	160,0
1614893	13,90	13,90	108,0	160,0
1614894	14,00	14,00	108,0	160,0
1614895	14,50	14,50	114,0	169,0
1614896	15,00	15,00	114,0	169,0
1614897	15,50	15,50	120,0	178,0
1614898	16,00	16,00	120,0	178,0
1614899	16,50	16,50	125,0	184,0
1614900	17,00	17,00	125,0	184,0
1614901	17,50	17,50	130,0	191,0
1614902	18,00	18,00	130,0	191,0
1614903	18,50	18,50	135,0	198,0
1614904	19,00	19,00	135,0	198,0
1614905	20,00	20,00	140,0	205,0

Свёрла спиральные с цилиндрическим хвостовиком, оснащённые пластинами из твёрдого сплава. Укороченные. Правые

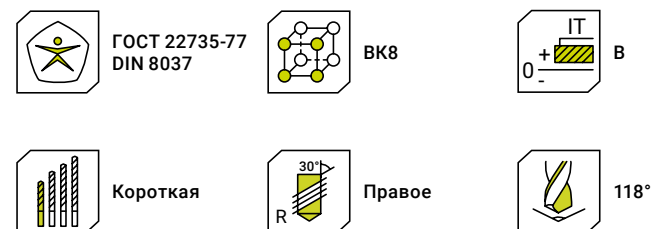
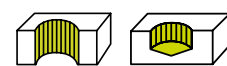

Артикул	Обозначение по ГОСТ	D, мм	d, мм	l, мм	L, мм
1177996	—	3,0	3,0	20,0	50,0
1177997	—	3,2	3,2	25,0	56,0
1177998	—	3,5	3,5	25,0	56,0
1177999	—	4,0	4,0	25,0	56,0
1178000	—	4,2	4,2	28,0	63,0
1178001	—	4,5	4,5	28,0	63,0
1178002	2300-1201	5,0	5,0	36,0	70,0
1253260	2300-1202	5,1	5,1	36,0	70,0
1252561	2300-1203	5,2	5,2	36,0	70,0
1253261	2300-1247	5,3	5,3	36,0	70,0
1289428	2300-1248	5,4	5,4	40,0	75,0
1178810	2300-1204	5,5	5,5	40,0	75,0
1253262	2300-1205	5,6	5,6	40,0	75,0
1253263	2300-1206	5,7	5,7	40,0	75,0
1289429	2300-1207	5,8	5,8	40,0	75,0
1478677	2300-1249	5,9	5,9	40,0	75,0
1178003	2300-1208	6,0	6,0	40,0	75,0
1178811	2300-1209	6,1	6,1	42,0	80,0
1253264	2300-1210	6,2	6,2	42,0	80,0
1289430	2300-1250	6,4	6,4	42,0	80,0
1178812	2300-1212	6,5	6,5	42,0	80,0
1254679	2300-1213	6,7	6,7	42,0	80,0
1265339	2300-1252	6,8	6,8	45,0	85,0
1178004	2300-1214	7,0	7,0	45,0	85,0
1253265	2300-1215	7,1	7,1	45,0	85,0
1178813	2300-1216	7,2	7,2	45,0	85,0
1253266	2300-1217	7,3	7,3	45,0	85,0
1178814	2300-1218	7,5	7,5	45,0	85,0
1178005	2300-1222	8,0	8,0	52,0	95,0
1178006	2300-1223	8,1	8,1	52,0	95,0
1253267	2300-1224	8,2	8,2	52,0	95,0
1178007	2300-1227	8,5	8,5	52,0	95,0
1253268	2300-1230	9,0	9,0	55,0	100,0
1261409	2300-1258	9,3	9,3	55,0	100,0

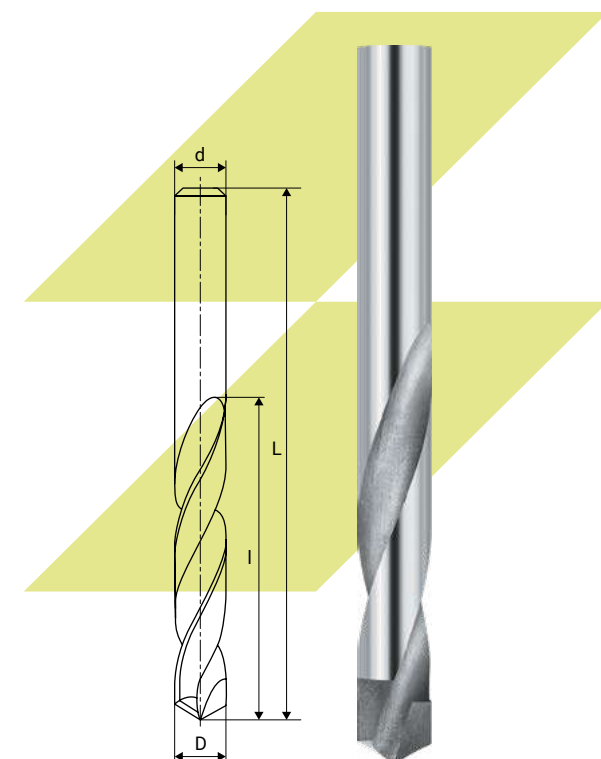

Артикул	Обозначение по ГОСТ	D, мм	d, мм	l, мм	L, мм
1253269	2300-1232	9,5	9,5	55,0	100,0
1178008	2300-1235	10,0	10,0	60,0	105,0
1252562	2300-1237	10,2	10,2	60,0	105,0
1220836	2300-1241	11,0	11,0	65,0	110,0
1378725	2300-1242	11,2	11,2	65,0	110,0
1289435	2300-1243	11,5	11,5	65,0	110,0
1378726	2300-1245	11,9	11,9	70,0	120,0
1178009	2300-1246	12,0	12,0	70,0	120,0
1252563	2300-8747	12,2	12,2	70,0	120,0
1178815	2300-8774	12,5	12,5	70,0	120,0

Артикул	Обозначение по ГОСТ	D, мм	d, мм	l, мм	L, мм
1178816	2300-8818	13,0	13,0	70,0	120,0
1289450	2300-8845	13,3	13,3	70,0	122,0
1178817	2300-8863	13,5	13,5	70,0	122,0
1178818	2300-8907	14,0	14,0	70,0	122,0
1178819	2300-8925	14,5	14,5	75,0	130,0
1178820	2300-8943	15,0	15,0	75,0	130,0
1178821	2300-8969	15,5	15,5	80,0	138,0
1326568	2300-8978	15,75	15,75	80,0	138,0
1178822	2300-8987	16,0	16,0	80,0	138,0
1178823	—	20,0	20,0	112,0	162,0

Свёрла спиральные с цилиндрическим хвостовиком, оснащённые пластинами из твёрдого сплава. Нормальной длины. Правые

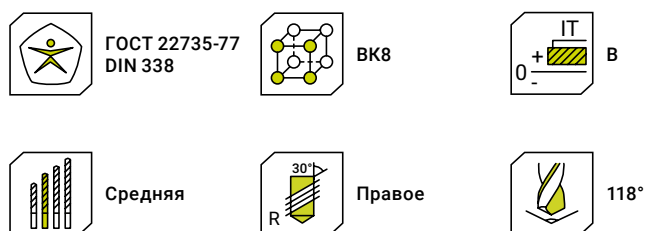

Артикул	Обозначение по ГОСТ	D, мм	d, мм	l, мм	L, мм
1425771	—	3,1	3,1	36,0	65,0
1425772	—	3,5	3,5	39,0	70,0
1425773	—	4,1	4,1	43,0	75,0
1289422	—	4,2	4,2	43,0	75,0
1289423	—	4,5	4,5	47,0	80,0
1343096	2300-8265	5,0	5,0	52,0	86,0
1425774	2300-8272	5,1	5,1	52,0	86,0
1343097	2300-8278	5,2	5,2	52,0	86,0
1343098	2300-8298	5,5	5,5	57,0	93,0
1289424	2300-8332	6,0	6,0	57,0	93,0
1343099	2300-8345	6,2	6,2	63,0	101,0
1343100	2300-8365	6,5	6,5	63,0	101,0
1289425	2300-8398	7,0	7,0	69,0	109,0
1343101	2300-8432	7,5	7,5	69,0	109,0
1289426	2300-8452	7,8	7,8	75,0	117,0
1343102	2300-8465	8,0	8,0	75,0	117,0
1418452	2300-8485	8,3	8,3	75,0	117,0
1343103	2300-8498	8,5	8,5	75,0	117,0
1417906	2300-8505	8,6	8,6	81,0	125,0
1343104	2300-8532	9,0	9,0	81,0	125,0
1343105	2300-8565	9,5	9,5	81,0	125,0
1417907	2300-8585	9,8	9,8	87,0	133,0
1289427	2300-8598	10,0	10,0	87,0	133,0
1343106	2300-8612	10,2	10,2	87,0	133,0
1417908	2300-8618	10,3	10,3	87,0	133,0
1418453	2300-8633	10,5	10,5	87,0	133,0
1343107	2300-8665	11,0	11,0	94,0	142,0
1343108	2300-8698	11,5	11,5	94,0	142,0
1417909	2300-8718	11,8	11,8	94,0	142,0
1343109	2300-8732	12,0	12,0	101,0	151,0
1343110	2300-8775	12,5	12,5	101,0	151,0
1343111	2300-8819	13,0	13,0	101,0	151,0
1343112	2300-8908	14,0	14,0	108,0	160,0
1343113	2300-8944	15,0	15,0	114,0	169,0
1343114	2300-8988	16,0	16,0	120,0	178,0

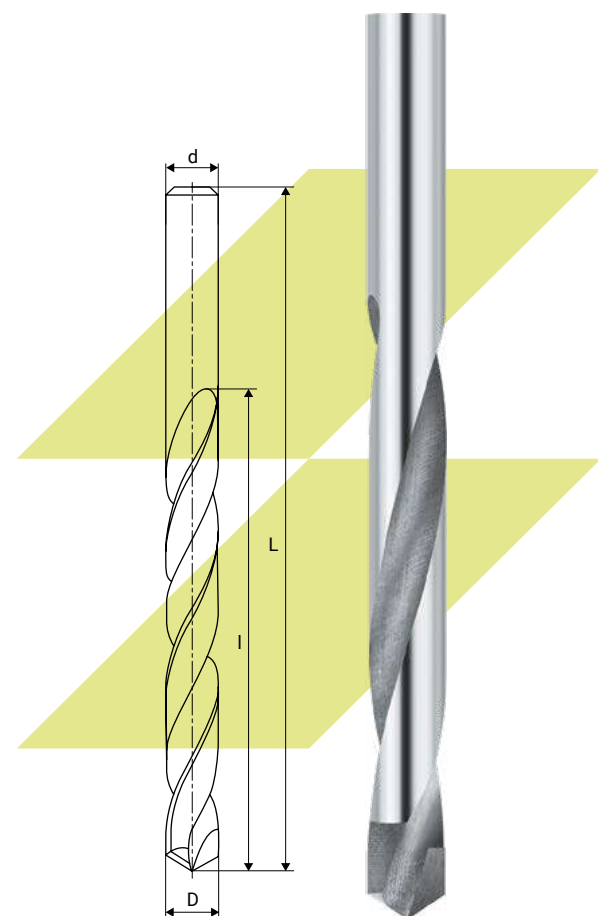

Свёрла твердосплавные для печатных плат. Хвостовик 2 мм

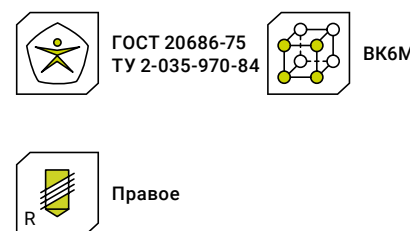
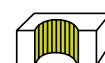

Артикул	D, мм	d, мм	L, мм
1170373	0,40	2,00	30,0
1170376	0,45	2,00	30,0
1170378	0,50	2,00	30,0
1170382	0,55	2,00	30,0
1170383	0,60	2,00	30,0
1220563	0,65	2,00	30,0
1170387	0,70	2,00	30,0
1170391	0,80	2,00	30,0
1170394	0,85	2,00	30,0
1170396	0,90	2,00	30,0
1170401	0,95	2,00	30,0
1170403	1,00	2,00	30,0
1170407	1,05	2,00	30,0
1170408	1,10	2,00	30,0
1170414	1,15	2,00	30,0
1170416	1,20	2,00	30,0
1184372	1,25	2,00	30,0
1170420	1,30	2,00	30,0
1170424	1,40	2,00	30,0
1170428	1,45	2,00	30,0
1170430	1,50	2,00	30,0
1170436	1,60	2,00	30,0
1170440	1,65	2,00	30,0
1170443	1,70	2,00	30,0
1170447	1,75	2,00	30,0
1170449	1,80	2,00	30,0
1170451	1,85	2,00	30,0
1170453	1,90	2,00	30,0
1170458	1,95	2,00	30,0
1170459	2,00	2,00	30,0

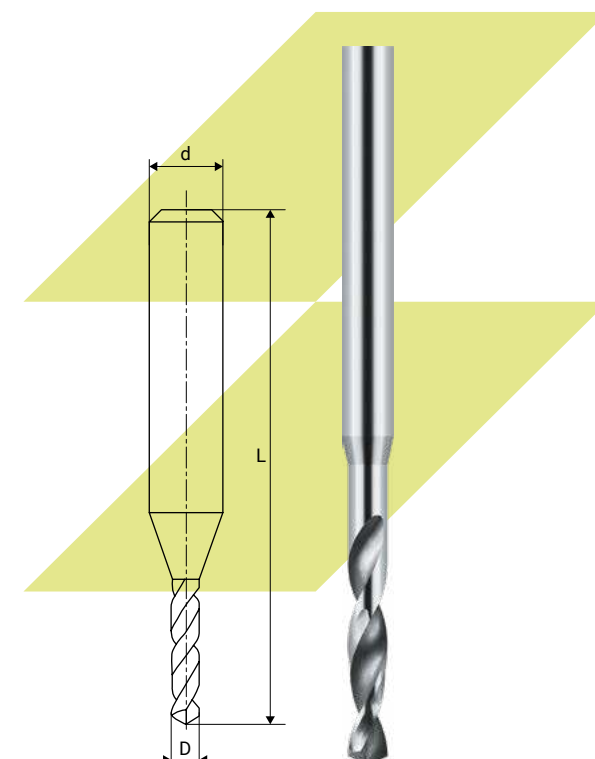

Свёрла твердосплавные для печатных плат. Хвостовик 3 мм

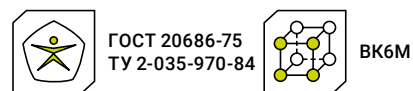
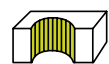

Артикул		D, мм	d, мм	L, мм
1170374	●	0,40	3,0	30,0
1170377	●	0,45	3,0	30,0
1170388	●	0,70	3,0	30,0
1170398	●	0,90	3,0	30,0
1170402	●	0,95	3,0	30,0
1170404	●	1,00	3,0	30,0
1170411	●	1,10	3,0	30,0
1170417	●	1,20	3,0	30,0
1170419	●	1,25	3,0	30,0
1170422	●	1,30	3,0	30,0
1170426	●	1,40	3,0	30,0
1170429	●	1,45	3,0	30,0
1170432	●	1,50	3,0	30,0
1170435	●	1,55	3,0	30,0
1170438	●	1,60	3,0	30,0
1170441	●	1,65	3,0	30,0
1170445	●	1,70	3,0	30,0
1170448	●	1,75	3,0	30,0
1170450	●	1,80	3,0	30,0
1170452	●	1,85	3,0	30,0
1170456	●	1,90	3,0	30,0
1170461	●	2,20	3,0	30,0
1170466	●	2,80	3,0	30,0
1170468	●	2,90	3,0	30,0

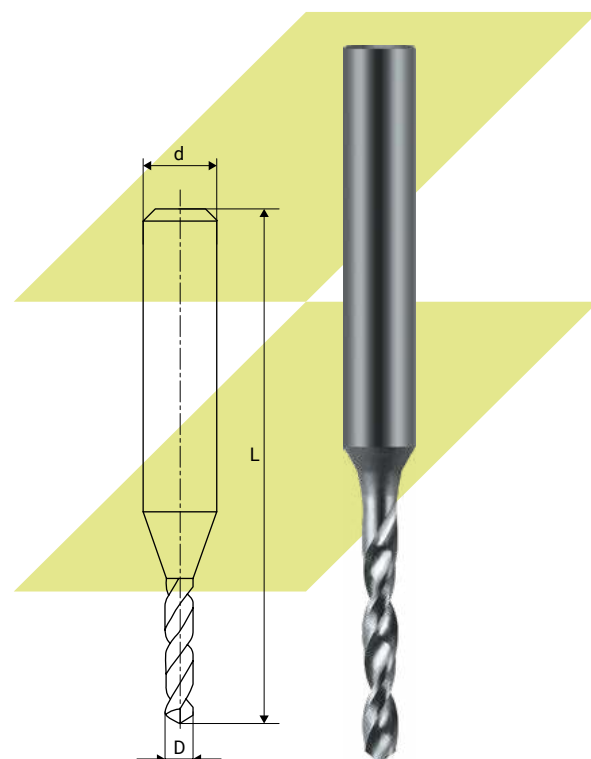

Свёрла твердосплавные для печатных плат. Хвостовик 3,175 мм

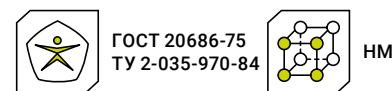
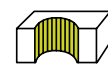

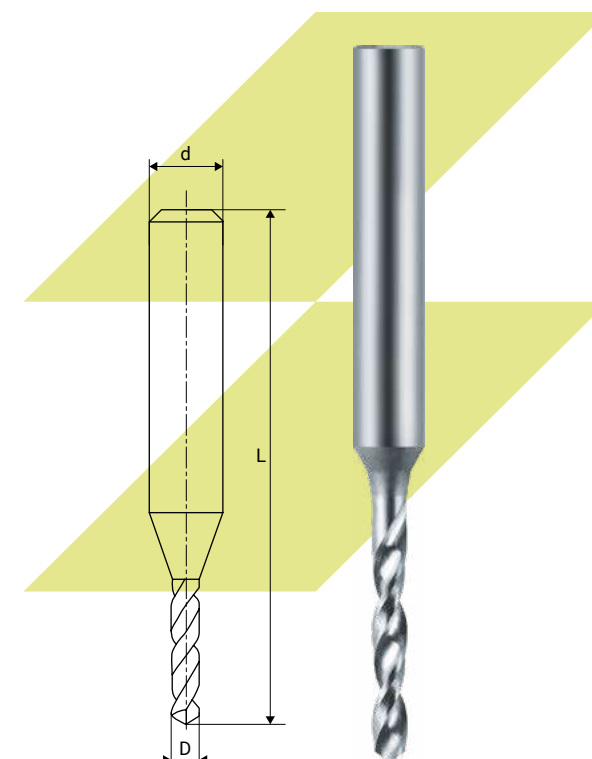

Артикул		D, мм	d, мм	L, мм
1612957	●	0,20	3,175	38,1
1612961	●	0,30	3,175	38,1
1612121	●	0,40	3,175	38,1
1612980	●	0,50	3,175	38,1
1852305	●	0,55	3,175	38,1
1612124	●	0,60	3,175	38,1
1612971	●	0,65	3,175	38,1
1612126	●	0,70	3,175	38,1
1612973	●	0,75	3,175	38,1
1612128	●	0,80	3,175	38,1
1612129	●	0,85	3,175	38,1
1612130	●	0,90	3,175	38,1
1612132	●	0,95	3,175	38,1
1612133	●	1,00	3,175	38,1
1612201	●	1,05	3,175	38,1
1612202	●	1,10	3,175	38,1
1612203	●	1,15	3,175	38,1
1612204	●	1,20	3,175	38,1
1612205	●	1,25	3,175	38,1
1612206	●	1,30	3,175	38,1
1612207	●	1,35	3,175	38,1
1612208	●	1,40	3,175	38,1
1612209	●	1,45	3,175	38,1
1612210	●	1,50	3,175	38,1
1612211	●	1,55	3,175	38,1
1612212	●	1,60	3,175	38,1
1612213	●	1,65	3,175	38,1
1612214	●	1,70	3,175	38,1
1612215	●	1,75	3,175	38,1
1612216	●	1,80	3,175	38,1
1612217	●	1,85	3,175	38,1
1612218	●	1,90	3,175	38,1
1612220	●	2,00	3,175	38,1
1612155	●	2,10	3,175	38,1

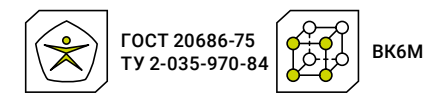
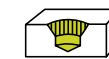

Артикул		D, мм	d, мм	L, мм
1612163	●	2,50	3,175	38,1
1612165	●	2,60	3,175	38,1
1612169	●	2,80	3,175	38,1
1612171	●	2,90	3,175	38,1
1612173	●	3,00	3,175	38,1
1612227	●	3,50	3,175	38,1
1612237	●	4,00	3,175	38,1
1612247	●	4,50	3,175	38,1
1612249	●	4,60	3,175	38,1
1612255	●	4,90	3,175	38,1

Свёрла твердосплавные для печатных плат комбинированные. Хвостовик 2 мм



Артикул		Обозначение по ГОСТ	D, мм	d, мм	L, мм
1345646	●	—	0,70	2,0	32,0
1236243	●	2317-0202	0,85	2,0	32,0
1170477	●	2317-0203	0,90	2,0	32,0
1170481	●	2317-0205	1,00	2,0	32,0
1170486	●	2317-0207	1,10	2,0	32,0
1170489	●	2317-0209	1,20	2,0	32,0

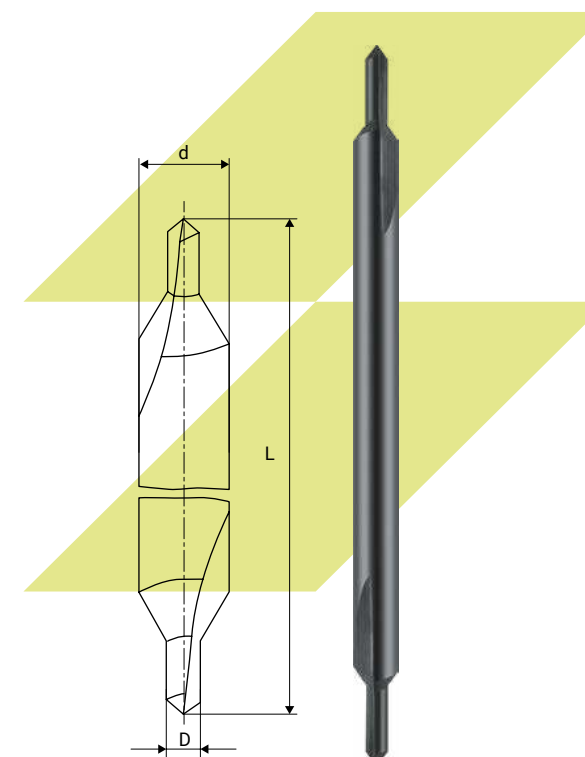

Свёрла твердосплавные для печатных плат комбинированные. Хвостовик 3 мм

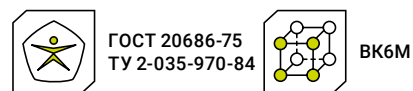

Артикул	Обозначение по ГОСТ	D, мм	d, мм	L, мм
1170475	—	0,80	3,0	35,0
1170473	—	0,85	3,0	35,0
1170478	—	0,90	3,0	35,0
1177357	—	0,95	3,0	35,0
1170482	—	1,00	3,0	35,0
1170485	—	1,05	3,0	35,0
1170487	—	1,10	3,0	35,0
1170488	—	1,15	3,0	35,0
1170491	—	1,20	3,0	35,0
1170492	2317-0212	1,30	3,0	35,0
1170493	2317-0214	1,40	3,0	35,0
1170494	2317-0215	1,45	3,0	35,0
1170495	2317-0216	1,50	3,0	35,0
1170497	2317-0217	1,60	3,0	35,0
1170499	2317-0219	1,80	3,0	35,0
1170500	2317-0221	1,90	3,0	35,0

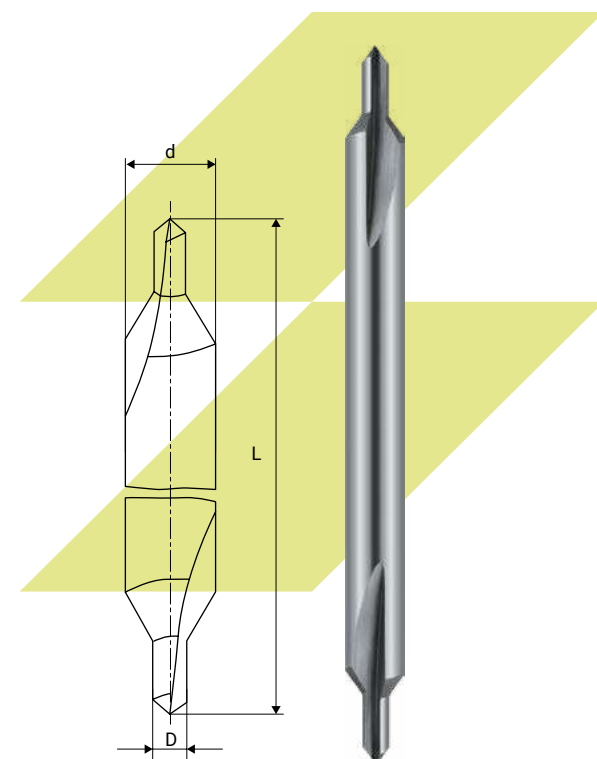

Свёрла спиральные с коническим хвостовиком, оснащённые пластинами из твёрдого сплава. Правые

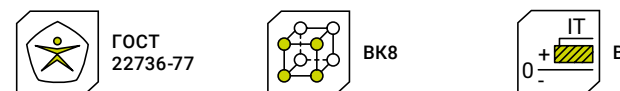

Артикул	Обозначение по ГОСТ	D, мм	Конус Морзе	I, мм	L, мм
1220026	—	8,00	KM1	75,0	156,0
1252564	—	8,20	KM1	75,0	156,0
1220027	—	9,00	KM1	81,0	162,0
1170512	—	9,50	KM1	90,0	175,0
1335535	2301-1378	10,00	KM1	87,0	168,0
1265318	2301-1380	10,20	KM1	87,0	168,0
1518233	2301-1382	10,50	KM1	87,0	168,0
1261595	2301-1384	11,00	KM1	94,0	175,0
1289451	2301-1385	11,20	KM1	94,0	175,0
1220028	2301-1389	12,00	KM1	101,0	199,0
1220029	2301-1390	12,50	KM1	101,0	199,0
1293052	2301-1395	13,70	KM2	108,0	206,0
1261596	2301-1396	14,00	KM2	108,0	206,0
1323767	2301-1400	15,00	KM2	114,0	212,0
1256823	2301-1404	16,00	KM2	120,0	218,0
1220030	2301-1406	16,50	KM2	125,0	223,0
1218889	2301-1409	17,40	KM2	60,0	150,0
1258943	2301-1711	18,00	KM2	90,0	190,0
1583131	2301-1420	20,50	KM3	145,0	266,0
1170538	2301-1422	20,90	KM3	105,0	225,0
1335536	2301-1426	22,00	KM3	150,0	271,0
1252565	2301-1427	22,50	KM3	155,0	276,0
1220853	2301-1433	24,00	KM3	160,0	281,0
1261597	2301-1437	25,00	KM3	160,0	281,0
1252566	2301-1438	25,50	KM3	165,0	286,0
1170564	2301-1440	26,25	KM3	115,0	235,0
1170567	2301-1444	27,00	KM3	170,0	291,0
1265319	2301-1451	29,25	KM4	175,0	324,0
1336046	—	32,00	KM4	185,0	334,0
1170588	—	48,00	KM5	260,0	450,0

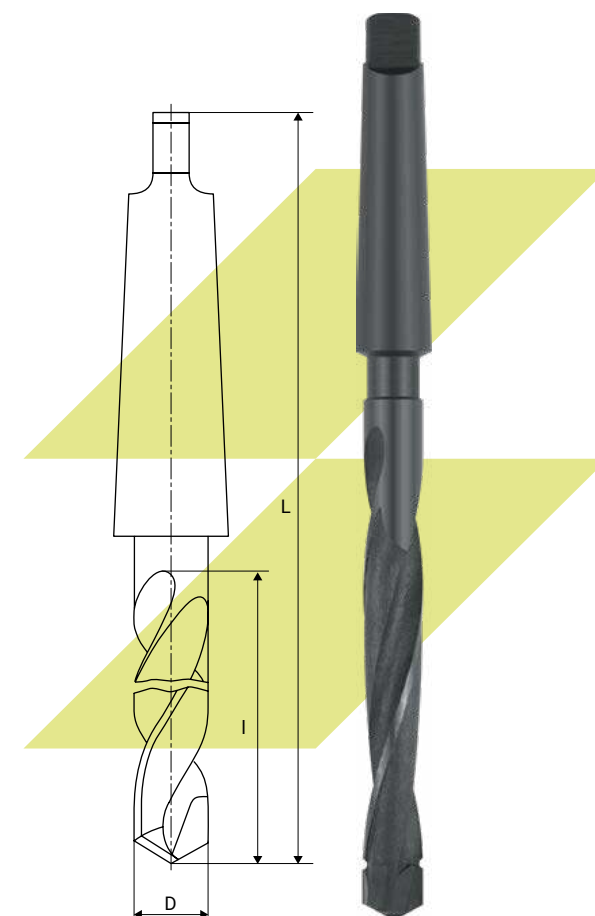

Свёрла центровочные твердосплавные комбинированные. Тип А

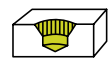

DIN 333 A



VK8



Полированное

Артикул		D, мм	d, мм	l, мм	L, мм
1478490	●	1,00	3,15	1,9	33,5
1478491	●	1,60	4,00	2,8	37,5
1478492	●	2,00	5,00	3,3	42,0
1478493	●	2,50	6,30	4,1	47,0
1478494	●	3,15	8,00	4,9	52,0
1478495	●	4,00	10,00	6,2	59,0
1478496	●	5,00	12,50	7,5	66,0
1478497	●	6,30	16,00	9,2	74,0

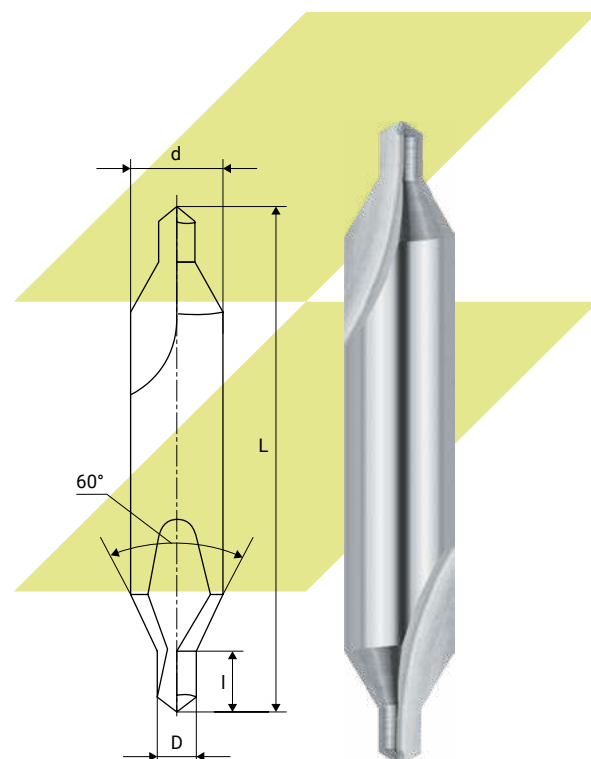

Свёрла центровочные комбинированные. Тип А

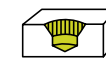

ГОСТ 14952-75
DIN 333



P6M5



Полированное

Артикул		Обозначение по ГОСТ	D, мм	d, мм	l, мм	L, мм
1236363	●	2317-0164	0,50	3,15	1,0	21,0
1236364	●	2317-0165	0,63	3,15	1,2	21,0
1236365	●	2317-0166	0,80	3,15	1,5	21,0
1238185	●	2317-0101	1,00	3,15	1,9	33,5
1238186	●	2317-0102	1,25	3,15	2,2	33,5
1236366	●	2317-0103	1,60	4,00	2,8	37,5
1236367	●	2317-0104	2,00	5,00	3,3	42,0
1240461	●	2317-0105	2,50	6,30	4,1	47,0
1236368	●	2317-0106	3,15	8,00	4,9	52,0
1236369	●	2317-0107	4,00	10,00	6,2	59,0
1240753	●	2317-0108	5,00	12,50	7,5	7,5

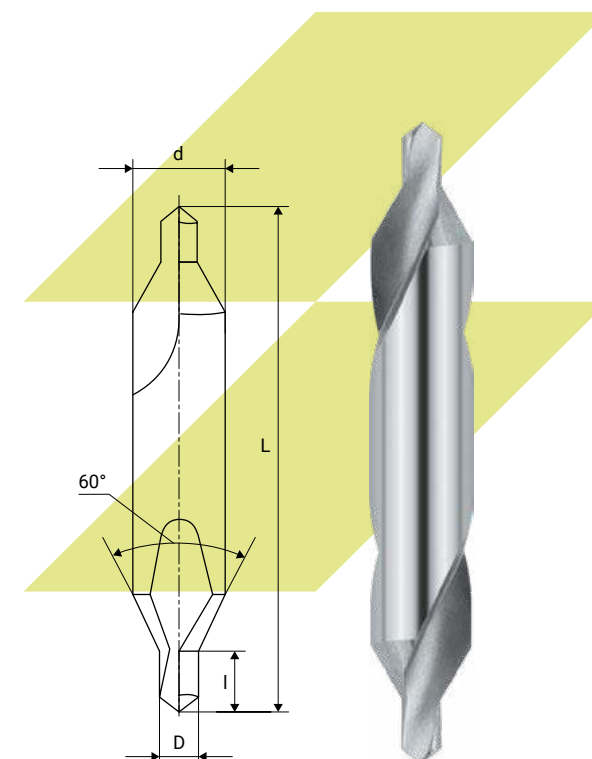

Свёрла центровочные комбинированные. Тип А

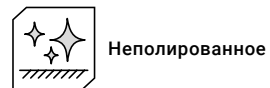
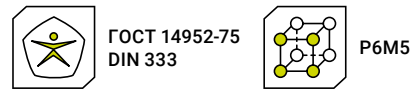
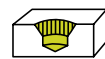

Артикул	Обозначение по ГОСТ	D, мм	d, мм	l, мм	L, мм
1174826	2317-0003	1,60	4,00	2,8	37,5
1171002	2317-0004	2,00	5,00	3,3	42,0
1171013	2317-0005	2,50	6,30	4,1	47,0
1171023	2317-0006	3,15	8,00	4,9	52,0
1171035	2317-0007	4,00	10,00	6,2	59,0
1171055	2317-0008	5,00	12,50	7,5	66,0
1174827	2317-0009	6,30	16,00	9,2	74,0
1174828	2317-0010	8,00	20,00	11,5	83,0
1174829	2317-0011	10,00	25,00	14,2	103,0
1174830	—	12,00	14,20	25,0	103,0

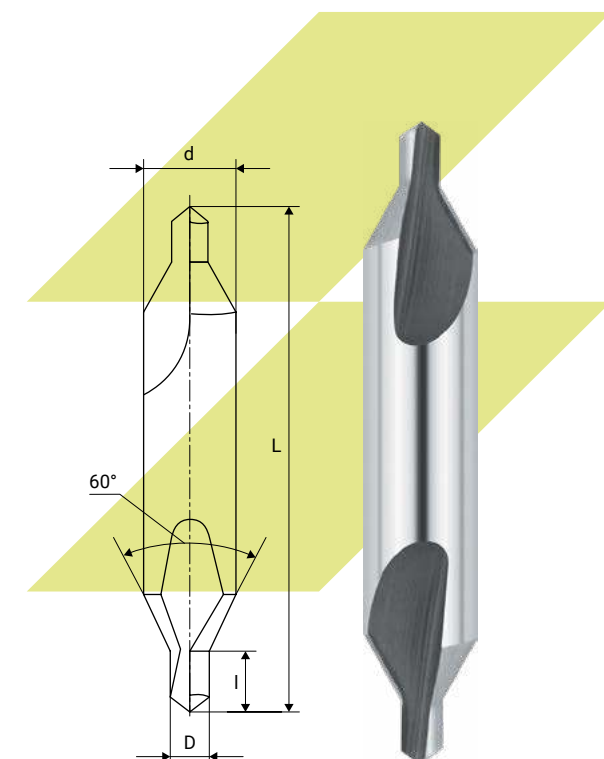

Свёрла центровочные комбинированные. Тип А

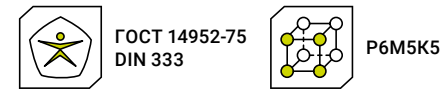
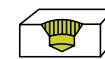

Артикул	Обозначение по ГОСТ	D, мм	d, мм	l, мм	L, мм
1377898	2317-0104	2,00	5,0	3,3	42,0
1377899	2317-0105	2,50	6,3	4,1	47,0
1377900	2317-0106	3,15	8,0	4,9	52,0

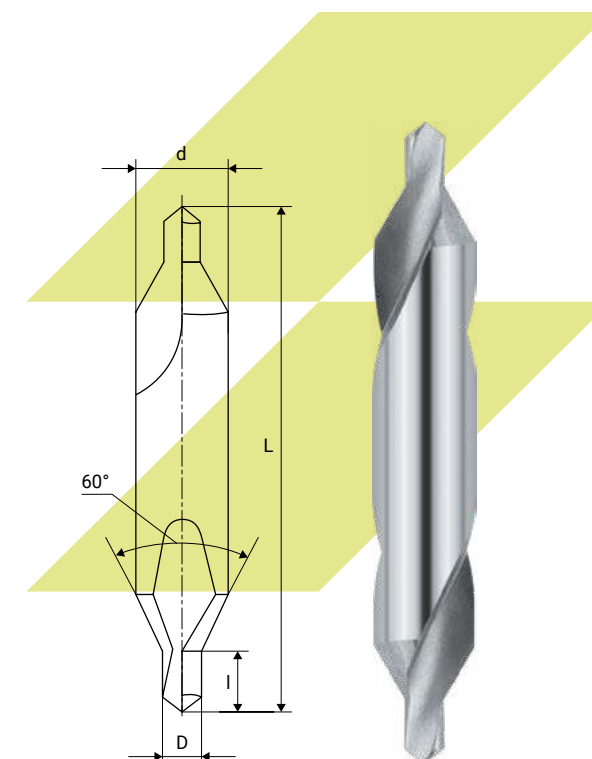

Свёрла центровочные комбинированные. Тип А

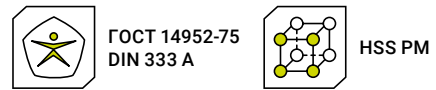
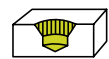

Артикул		D, мм	d, мм	l, мм	L, мм
1590972	●	1,00	5,00	1,50	40
1590973	●	1,50	6,00	2,50	40
1590974	●	2,00	6,00	3,00	45
1590975	●	2,50	6,00	3,50	50
1590976	●	3,00	8,00	4,00	55
1590977	●	4,00	8,00	5,50	55
1590978	●	4,00	10,00	5,50	65
1590979	●	5,00	10,00	6,50	65
1590980	●	5,00	11,00	6,50	78
1590981	●	6,00	12,00	7,50	78

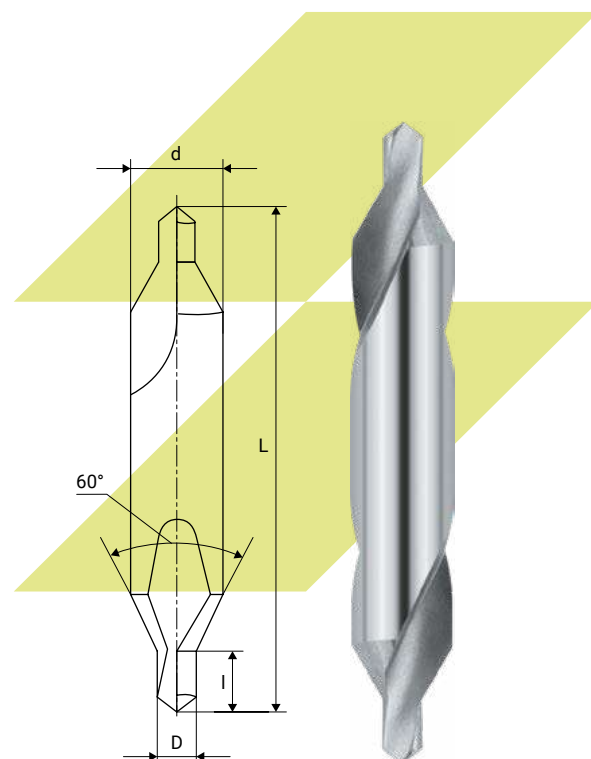

Свёрла центровочные комбинированные. Тип А

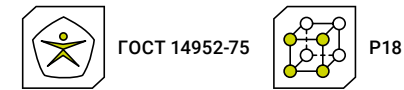
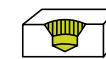

Артикул		Обозначение по ГОСТ	D, мм	d, мм	l, мм	L, мм
1805389	●	2317-0164	0,50	3,15	1,00	21,00
1805390	●	2317-0165	0,63	3,15	1,20	21,00
1805391	●	2317-0166	0,80	3,15	1,50	21,00
1805392	●	2317-0101	1,00	3,15	3,15	33,50
1805393	●	2317-0102	1,25	3,15	3,15	33,50
1614346	●	2317-0103	1,60	4,00	2,80	37,50
1614347	●	2317-0104	2,00	5,00	3,30	42,00
1614348	●	2317-0105	2,50	6,30	4,10	47,00
1614349	●	2317-0106	3,15	8,00	4,90	52,00
1614350	●	2317-0107	4,00	10,00	6,20	59,00
1614351	●	2317-0108	5,00	12,50	7,50	66,00
1614352	●	2317-0109	6,30	16,00	9,20	74,00

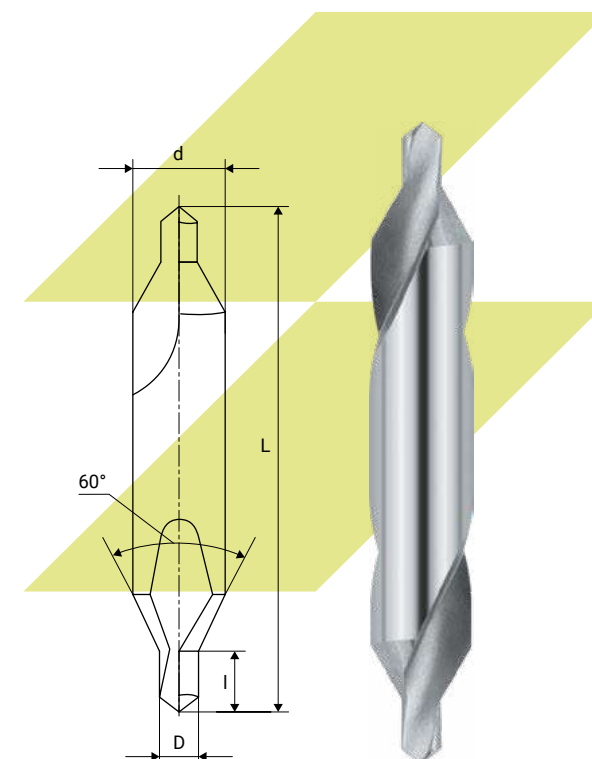

Свёрла центровочные комбинированные. Тип В

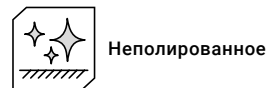
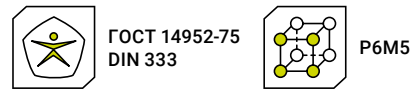
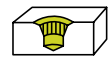

Артикул	Обозначение по ГОСТ	D, мм	d, мм	l, мм	L, мм
1417310	2317-0012	1,0	4,0	1,9	37,5
1170994	2317-0014	1,6	6,3	2,8	47,0
1171006	2317-0015	2,0	8,0	3,3	52,5
1171017	2317-0016	2,5	10,0	4,1	59,0
1171027	2317-0017	3,1	11,2	4,9	63,0
1171039	2317-0018	4,0	14,0	6,2	70,0
1171051	2317-0019	5,0	18,0	7,5	78,0
1177811	2317-0020	6,3	20,0	9,2	83,0
1276296	2317-0043	8,0	25,0	11,5	103,0
1276298	2317-0044	10,0	31,5	14,2	128,0

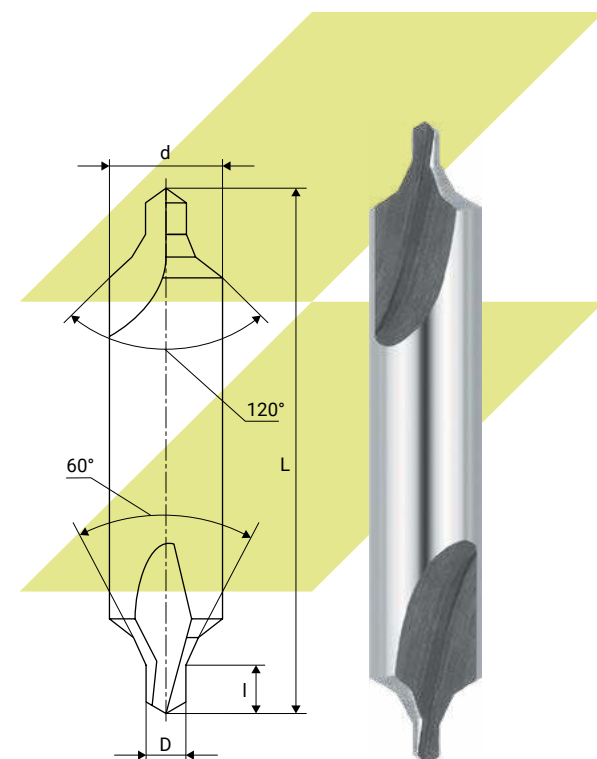

Свёрла центровочные комбинированные. Тип R

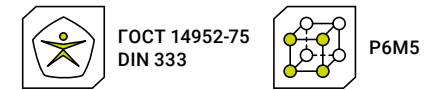
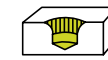

Артикул	Обозначение по ГОСТ	D, мм	d, мм	l, мм	L, мм
1417311	2317-0027	1,0	3,15	3,0	33,5
1418359	2317-0030	2,0	5,00	5,3	42,0
1417312	2317-0034	5,0	12,50	13,2	66,0
1276295	2317-0035	6,3	16,00	17,0	74,0
1276297	2317-0036	8,0	20,00	21,2	83,0
1276299	2317-0139	10,0	25,00	26,5	103,0

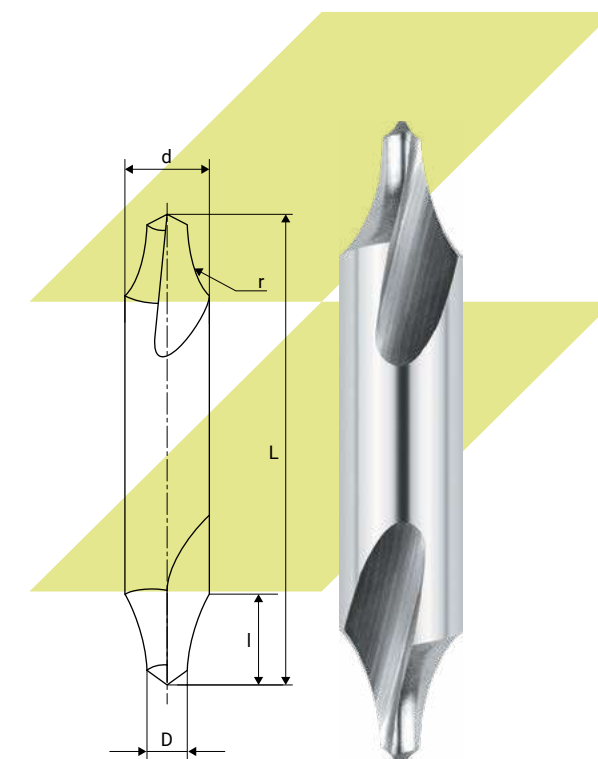

Свёрла центровочные с коническим хвостовиком. Тип А

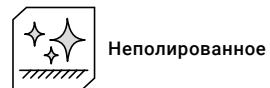
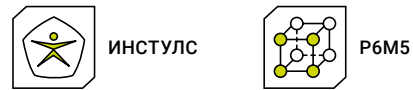
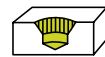

Артикул		D, мм	KM	I, мм	L, мм
1336013	●	10,0	KM3	15,0	250,0
1336014	●	12,0	KM3	15,0	250,0

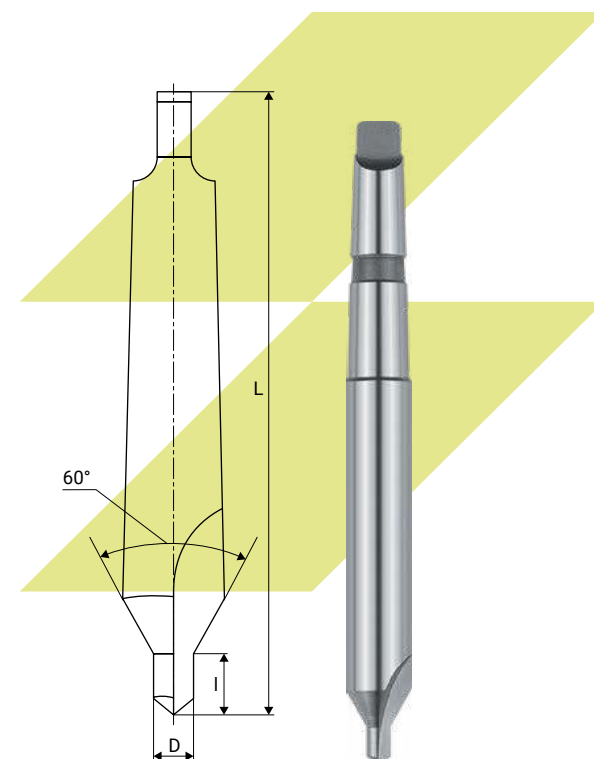

Свёрла сборные с механическим креплением пластин из быстрорежущей стали

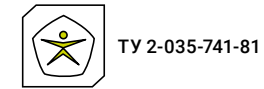

Артикул		D min мм	D max мм	KM	I, мм	L, мм
1252210	●	51,0	63,0	KM5	164,0	320,0

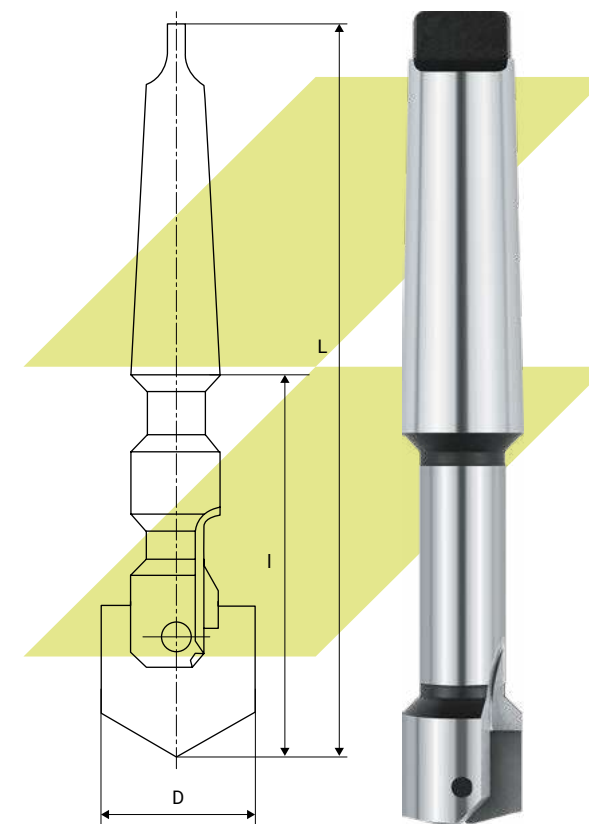

Пластины режущие из быстрорежущей стали для сборных перовых свёрл

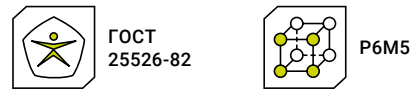
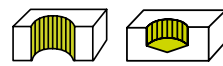

Артикул	Обозначение по ГОСТ	D, мм	b, мм	L, мм	d, мм
1237626	2000-1201	25,0	6,0	35,0	7,0
104421	2000-1212	30,0	6,0	35,0	7,0
1128139	2000-1217	35,0	7,0	40,5	8,0
104423	2000-1218	36,0	7,0	40,5	8,0
1128140	2000-1223	40,0	8,0	50,0	10,0
1128854	2000-1225	42,0	8,0	50,0	10,0
1254860	2000-1228	45,0	8,0	50,0	10,0
1220557	2000-1229	46,0	8,0	50,0	10,0
1220539	2000-1232	48,0	8,0	50,0	10,0
1127406	2000-1234	50,0	8,0	50,0	10,0
1234727	2000-1242	57,0	10,0	58,5	12,0
1127409	2000-1245	60,0	10,0	58,5	12,0
1237638	2000-1246	61,0	10,0	58,5	12,0
1127410	2000-1249	65,0	11,0	68,5	14,0
119090	2000-1254	75,0	11,0	68,5	14,0
1128658	2000-1258	85,0	14,0	68,5	18,0
1127544	2000-1261	90,0	14,0	83,5	18,0
1243693	2000-1263	95,0	14,0	83,5	18,0
1253494	2000-1264	98,0	14,0	83,5	18,0
1127431	2000-1269	110,0	18,0	99,0	22,0

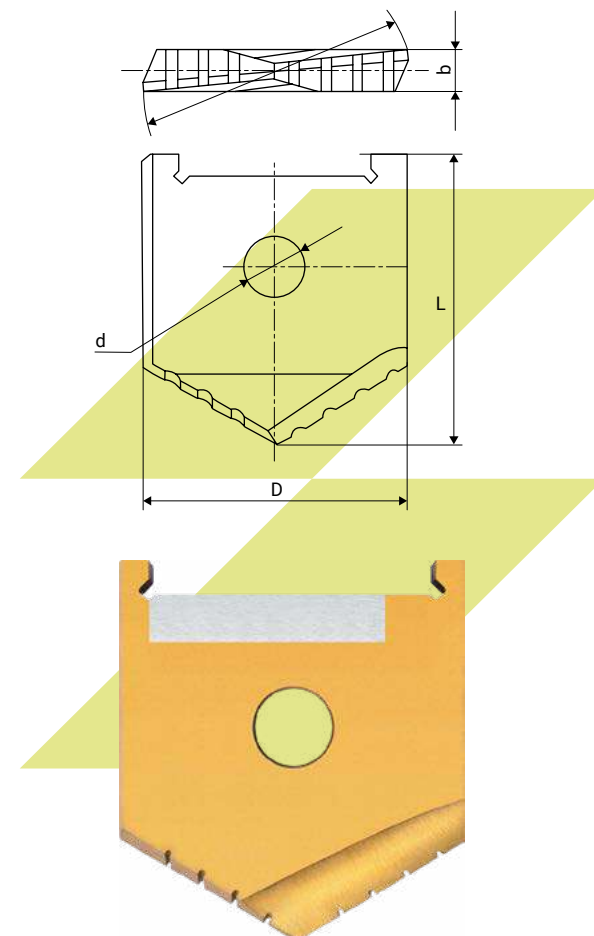

Свёрла ступенчатые

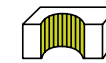

Артикул	D _{min'} , мм	D _{max'} , мм	d, дюйм/мм	Кол-во ступеней
1845816	4,0	12,0	1/4"	5
1845817	4,0	12,0	1/4"	9
1845818	4,0	20,0	8,0	9
1845819	4,0	30,0	10,0	14
1845820	4,0	39,0	10,0	13

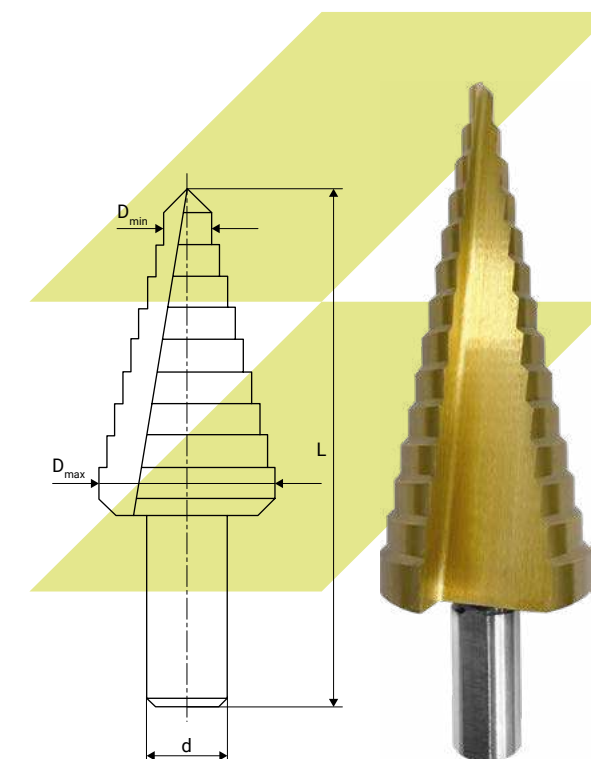

Свёрла ступенчатые

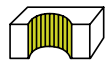

Артикул		D_{min} мм	D_{max} мм	d, мм	Кол-во ступеней
1845822	●	4,0	12,0	1/4"	5
1845823	●	4,0	12,0	1/4"	9
1845824	●	4,0	20,0	8,0	9
1845825	●	4,0	30,0	10,0	14
1845826	●	4,0	32,0	10,0	15
1845827	●	4,0	39,0	10,0	13
1845828	●	6,0	20,0	8,0	8
1845829	●	6,0	30,0	10,0	13
1845830	●	6,0	38,0	10,0	12

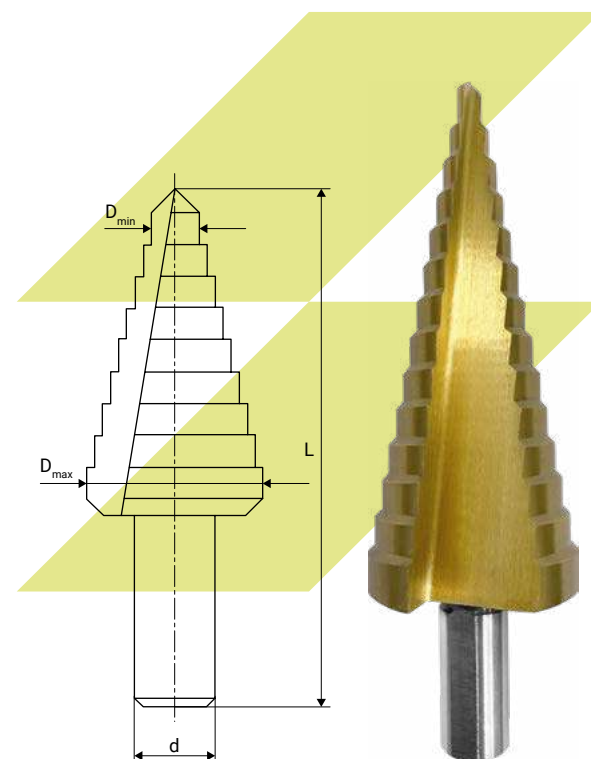

Свёрла по дереву спиральные

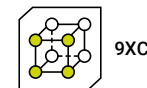

Артикул		D, мм	d, дюйм
1845877	●	3,0	1/4
1845878	●	4,0	1/4
1845879	●	5,0	1/4
1845880	●	6,0	1/4
1845881	●	7,0	1/4
1845882	●	8,0	1/4
1845883	●	9,0	1/4
1845884	●	10,0	1/4
1845885	●	12,0	1/4
1845886	●	13,0	1/4

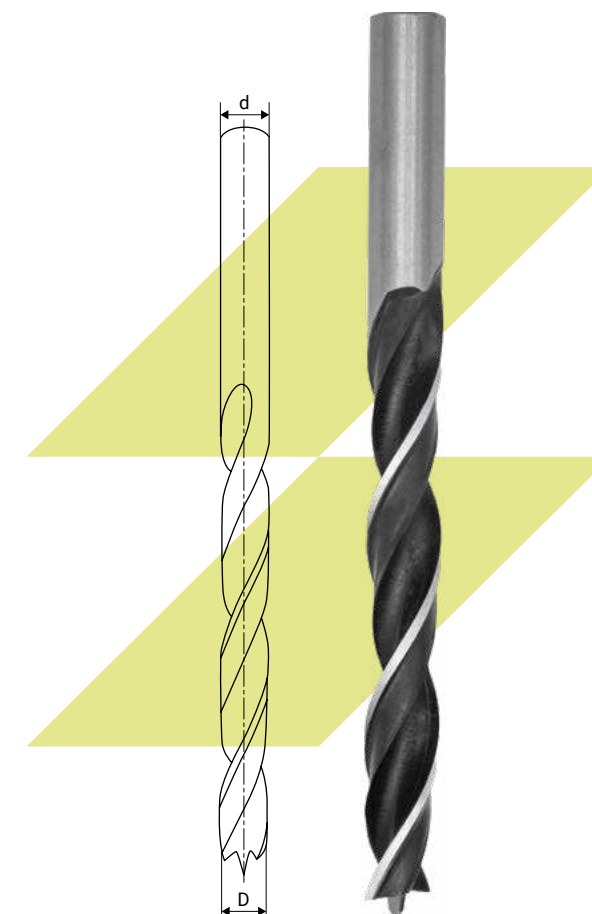

Свёрла по дереву перовые

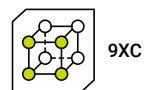
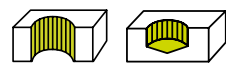

Артикул		D, мм	d, дюйм
1845888	●	6,0	1/4
1845889	●	8,0	1/4
1845890	●	10,0	1/4
1845891	●	12,0	1/4
1845892	●	14,0	1/4
1845893	●	16,0	1/4
1845894	●	18,0	1/4
1845895	●	20,0	1/4
1845896	●	22,0	1/4
1845897	●	25,0	1/4
1845898	●	30,0	1/4
1845899	●	35,0	1/4
1845900	●	38,0	1/4
1845901	●	40,0	1/4

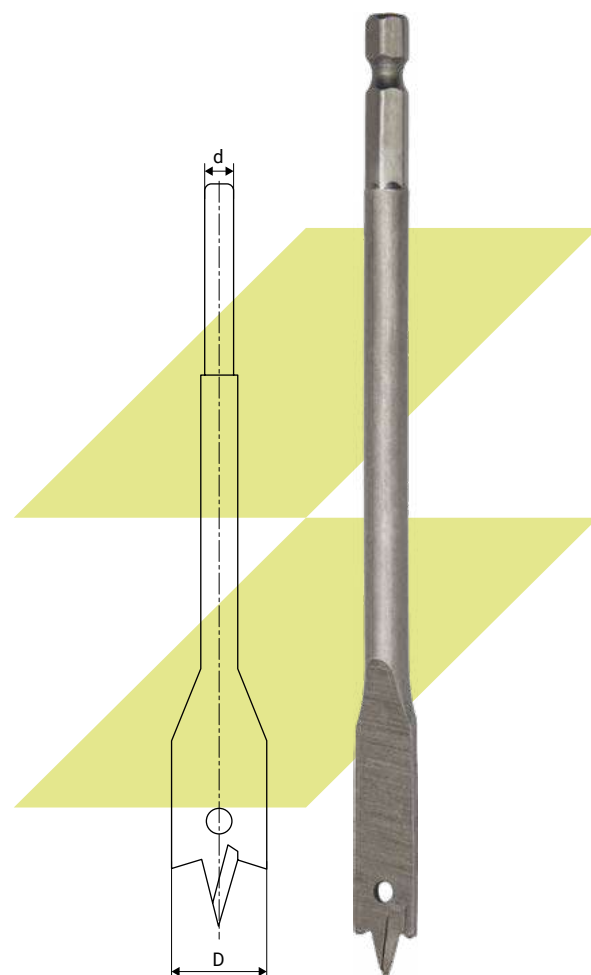

Свёрла по кафелю и стеклу

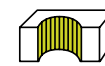

Артикул		D, мм	d, дюйм/мм	L, мм	Кол-во зубьев
1845921	●	3,0	2,8	72,0	2
1845903	●	3,0	1/4"	73,0	2
1845912	●	3,0	1/4"	75,0	4
1845922	●	4,0	3,5	68,0	2
1845904	●	4,0	1/4"	75,0	2
1845913	●	4,0	1/4"	75,0	4
1845923	●	5,0	3,5	68,0	2
1845905	●	5,0	1/4"	75,0	2
1845914	●	5,0	1/4"	75,0	4
1845924	●	6,0	4,5	70,0	2
1845906	●	6,0	1/4"	77,0	2
1845915	●	6,0	1/4"	78,0	4
1845925	●	8,0	5,5	72,0	2
1845907	●	8,0	1/4"	79,0	2
1845916	●	8,0	1/4"	82,0	4
1845926	●	10,0	7,0	80,0	2
1845908	●	10,0	1/4"	83,0	2
1845917	●	10,0	1/4"	83,0	4
1845927	●	12,0	8,0	82,0	2
1845909	●	12,0	1/4"	86,0	2
1845918	●	12,0	1/4"	86,0	4
1845910	●	14,0	1/4"	85,0	2
1845919	●	14,0	1/4"	87,0	4
1845928	●	14,0	10,0	87,0	2
1845911	●	16,0	1/4"	88,0	2
1845920	●	16,0	1/4"	88,0	4
1845929	●	16,0	10,5	92,0	2

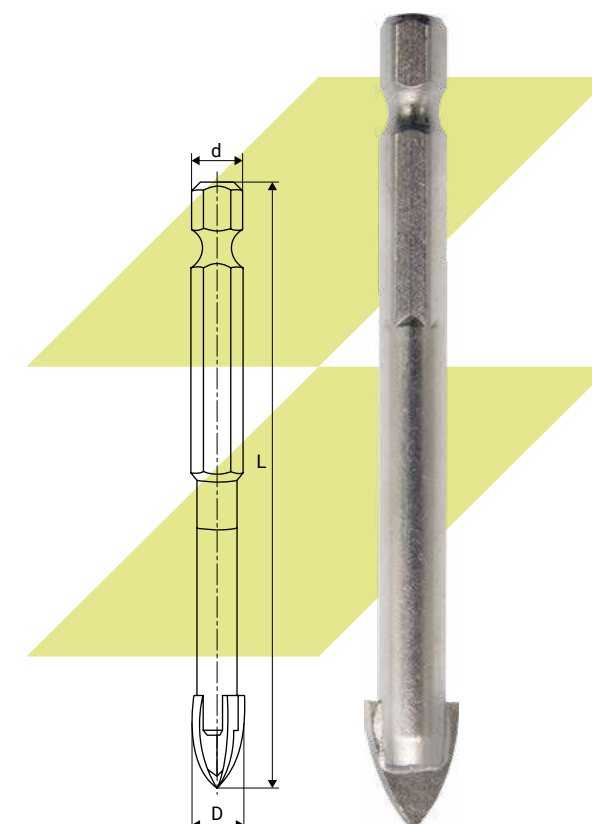

Набор свёрл

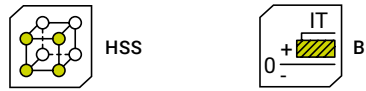

Артикул		d1 _{min'} мм	d2 _{max'} мм	Кол-во предметов	Футляр
1518403	●	1,0	10,0	10	пластик
1518405	●	1,0	10,0	19	металл
1518409	●	1,0	13,0	25	металл
1518411	●	1,5	6,5	13	пластик
1518413	●	2,0	8,0	6	пластик
1518415	●	3,0	10,0	8	пластик

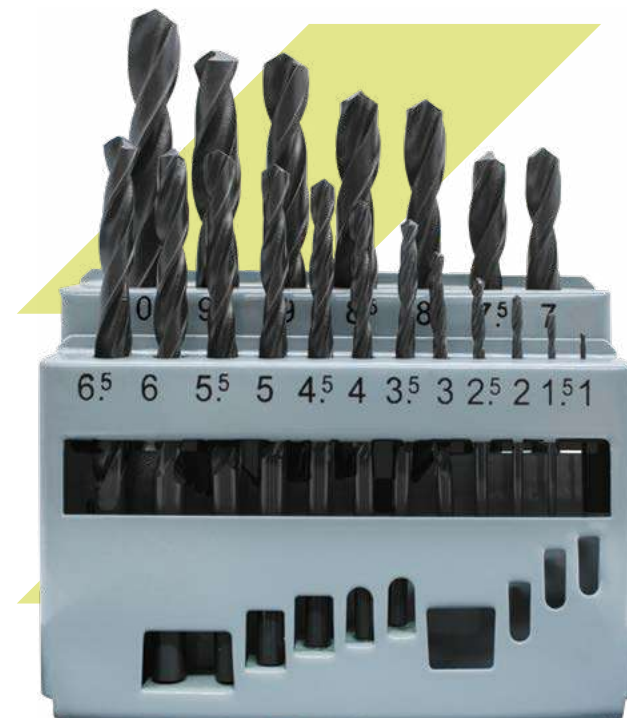

Набор свёрл

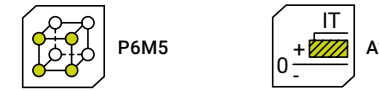

Артикул		d1 _{min'} мм	d2 _{max'} мм	Кол-во предметов	Футляр
1518404	●	1,0	10,0	10	пластик
1518406	●	1,0	10,0	19	металл
1518410	●	1,0	13,0	25	металл
1518412	●	1,5	6,5	13	пластик
1518414	●	2,0	8,0	6	пластик
1518416	●	3,0	10,0	8	пластик

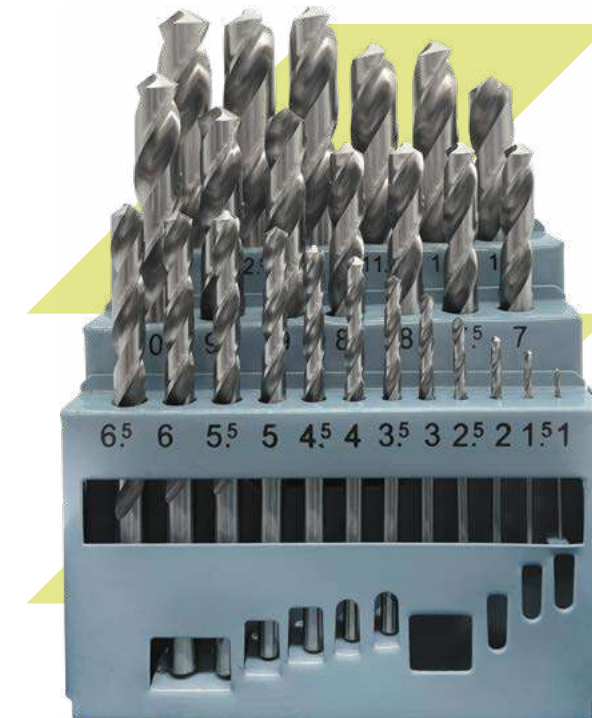

Зенкеры с цилиндрическим хвостовиком из быстрорежущей стали для обработки деталей из лёгких сплавов

P M K N S H

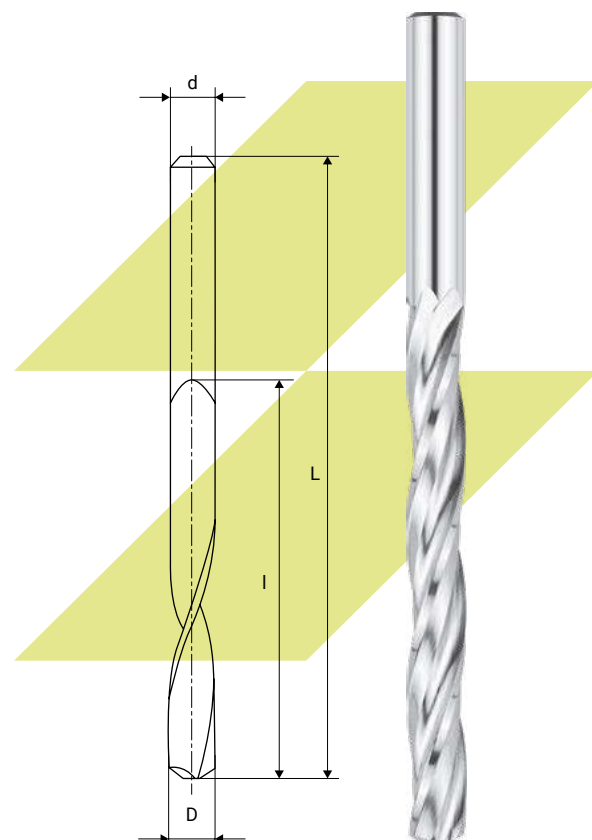
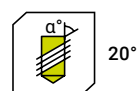
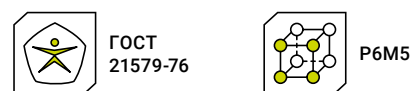
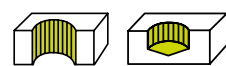

Артикул	Обозначение по ГОСТ	D, мм	d, мм	l, мм	L, мм	Z, шт	№
1416083	2320-0073	3,5	3,5	39,0	70,0	2	№1
1416084	2320-0074	3,5	3,5	39,0	70,0	2	№2
1416085	2320-0075	4,0	4,0	43,0	75,0	2	№1
1416086	2320-0076	4,0	4,0	43,0	75,0	2	№2
1416087	2320-0077	4,5	4,5	47,0	80,0	2	№1
1416088	2320-0078	4,5	4,5	47,0	80,0	2	№2
1441500	2320-0084	7,0	7,0	69,0	109,0	3	№2
1441503	2320-0087	9,0	9,0	81,0	125,0	3	№1

Зенкеры с коническим хвостовиком из быстрорежущей стали

P M K N S H

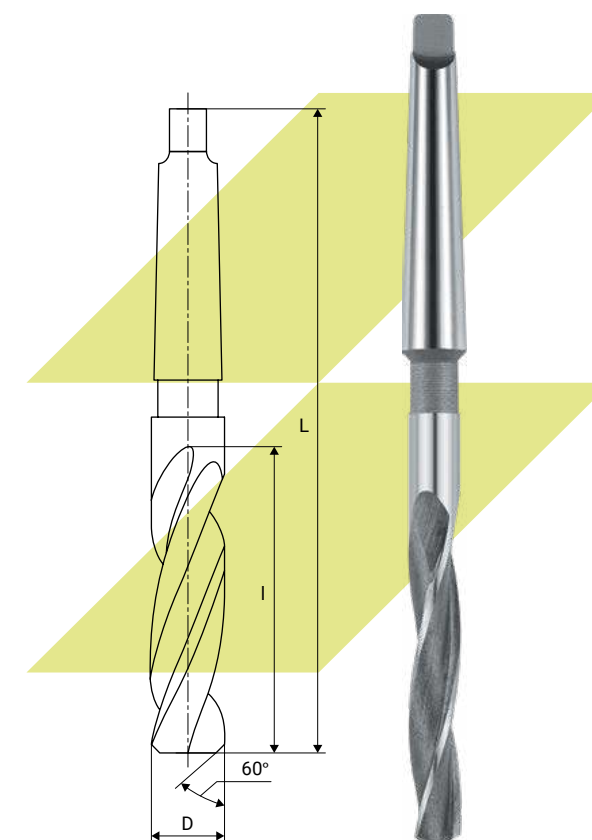
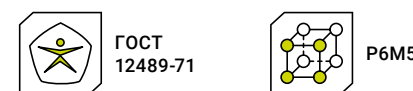
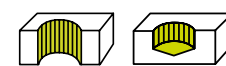

Артикул	Обозначение по ГОСТ	D, мм	KM	l, мм	L, мм	Z, шт
1174542	2320-2558	11,00	KM1	94,0	175,0	3
118193	2320-2561	12,00	KM1	100,0	190,0	4
1378566	2320-2563	13,00	KM1	120,0	255,0	3
1174561	2320-2565	14,00	KM1	130,0	215,0	3
1174566	2320-2568	15,00	KM1	114,0	212,0	3
1174578	2323-0522	16,00	KM2	120,0	218,0	3
1174585	2320-2574	17,00	KM2	125,0	223,0	3
1174601	2320-2578	19,00	KM2	135,0	233,0	3
1417219	2320-2585	22,00	KM2	260,0	360,0	3
1174630	—	22,88	KM2	120,0	220,0	3
1174639	2320-2592	24,00	KM3	120,0	240,0	3
1174659	2320-2596	26,00	KM3	165,0	286,0	3
1174661	—	27,00	KM3	130,0	250,0	3
1478486	2320-2601	30,00	KM3	175,0	296,0	3
1425807	2320-2607	34,00	KM4	130,0	280,0	3
1174686	—	34,50	KM4	185,0	285,0	3

Зенкеры с коническим хвостовиком из быстрорежущей стали

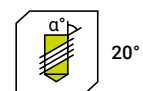
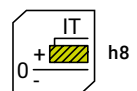
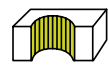

Артикул	Обозначение по ГОСТ	D, мм	KM	I, мм	L, мм	Z, шт
1416100	2320-2554	9,00	KM1	81,0	162,0	3
1257980	2320-2556	10,00	KM1	87,0	168,0	3
1257982	2320-2558	11,00	KM1	94,0	175,0	3
1257983	2320-2561	12,00	KM1	101,0	182,0	3
1257987	2320-2565	14,00	KM1	108,0	189,0	3
1257990	2320-2569	15,00	KM2	114,0	212,0	3
1257993	2320-2572	16,00	KM2	120,0	218,0	3
1257997	2320-2575	17,75	KM2	130,0	228,0	3
1257999	2320-2596	26,00	KM3	165,0	286,0	3
1258000	2320-2604	32,00	KM3	185,0	306,0	3
1416101	2320-2612	36,00	KM4	195,0	344,0	3
1425468	2320-2623	45,00	KM4	210,0	359,0	3
1425467	2320-2628	49,60	KM4	220,0	369,0	3

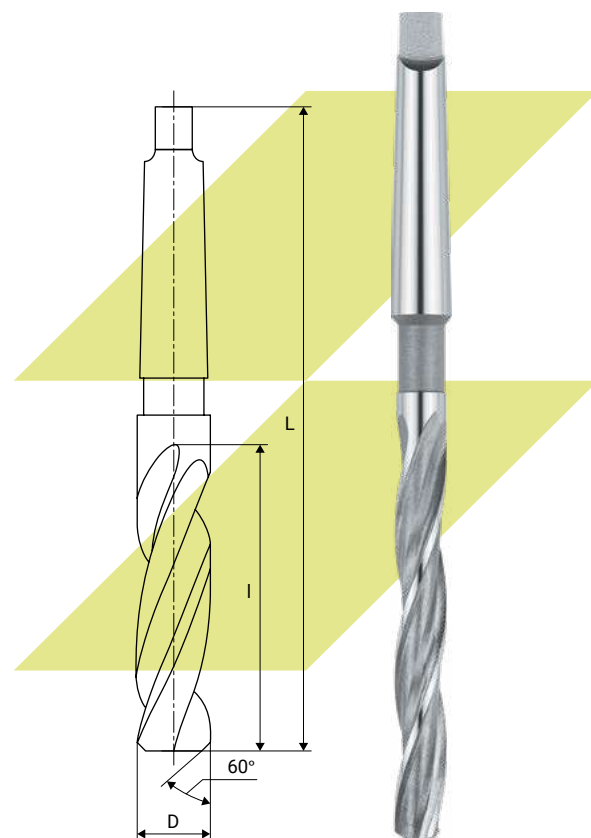

Зенкеры с коническим хвостовиком из быстрорежущей стали

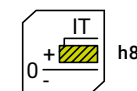
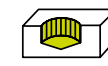

Артикул	Обозначение по ГОСТ	D, мм	KM	I, мм	L, мм	Z, шт
1257985	2320-2554	12,00	KM1	101,0	182,0	3
1257986	2320-2556	13,75	KM1	108,0	189,0	3
1257989	2320-2558	14,00	KM1	108,0	189,0	3
1257995	2320-2561	16,75	KM2	125,0	223,0	3
1425466	2320-2565	24,70	KM3	160,0	281,0	3

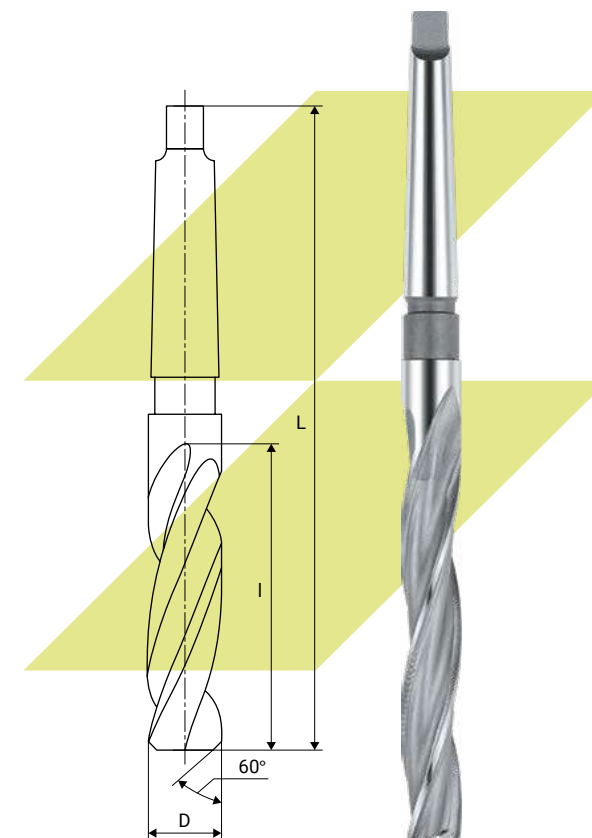

Развёртки ручные цилиндрические

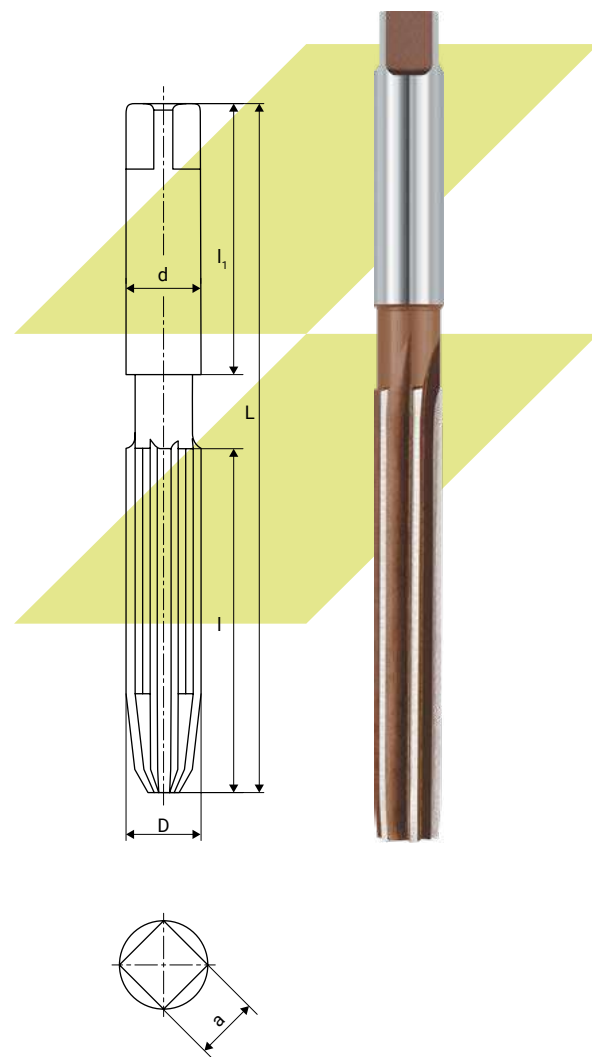
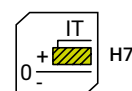
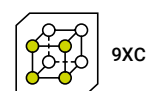
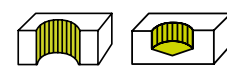

Артикул	Обозначение по ГОСТ	D, мм	d, мм	a, мм	l ₁ , мм	l ₂ , мм	L, мм	Z, шт
1179076	2360-0112	3,0	3,0	2,5	31,0	28,0	62,0	6
1425552	—	3,3	3,3	2,5	31,0	28,0	62,0	6
1425555	2360-0114	3,4	3,4	2,8	31,0	28,0	62,0	6
1425558	2360-0116	3,6	3,6	2,8	35,0	32,0	71,0	6
1425561	2360-0117	3,8	3,8	3,2	35,0	32,0	71,0	6
1179077	2360-0118	4,0	4,0	3,2	38,0	32,0	76,0	6
1425564	2360-0119	4,2	4,2	3,2	38,0	32,0	76,0	6
1425567	2360-0120	4,5	4,5	3,6	41,0	32,0	81,0	6
1417641	2360-0121	4,8	4,8	4,0	41,0	32,0	81,0	6
1179078	2360-0122	5,0	5,0	4,0	44,0	36,0	87,0	6

Артикул	Обозначение по ГОСТ	D, мм	d, мм	a, мм	l ₁ , мм	l ₂ , мм	L, мм	Z, шт
1425568	2360-0123	5,2	5,2	4,0	44,0	36,0	87,0	6
1179079	2360-0125	6,0	6,0	5,0	47,0	40,0	93,0	6
1220034	2360-0127	6,5	6,5	5,0	47,0	40,0	93,0	6
1179080	2360-0128	7,0	7,0	5,6	54,0	45,0	107,0	6
1179081	2360-0130	8,0	8,0	6,3	58,0	45,0	115,0	6
1177913	2360-0130	8,5	8,5	6,3	58,0	45,0	115,0	6
1240751	2360-0132	9,0	9,0	7,1	62,0	50,0	124,0	6
1425575	2360-0133	9,5	9,5	7,1	62,0	50,0	124,0	6
1179084	2360-0134	10,0	10,0	8,0	66,0	50,0	133,0	6
1177916	2360-0135	10,5	10,5	8,0	66,0	50,0	133,0	8
1177919	2360-0136	11,0	11,0	9,0	71,0	55,0	142,0	8
1177920	2360-0137	11,5	11,5	9,0	71,0	55,0	142,0	8
1179087	2360-0138	12,0	12,0	10,0	76,0	60,0	152,0	8
1289653	—	12,5	12,5	10,0	76,0	60,0	152,0	8
1220840	2360-0139	13,0	13,0	10,0	76,0	60,0	152,0	8
1179090	2360-0140	14,0	14,0	11,2	81,0	65,0	163,0	8
1220841	2360-0140	15,0	15,0	11,2	81,0	65,0	163,0	8
1220843	2360-0142	16,0	16,0	12,5	87,0	70,0	175,0	8
1376373	2360-0143	17,0	17,0	12,5	87,0	70,0	175,0	8
1376376	2360-0144	18,0	18,0	14,0	93,0	80,0	188,0	8
105762	2360-0145	19,0	19,0	14,0	93,0	80,0	188,0	8
1261546	2360-0146	20,0	20,0	16,0	100,0	80,0	201,0	8
1376380	2360-0147	21,0	21,0	16,0	100,0	80,0	201,0	8
1376383	2360-0148	22,0	22,0	18,0	107,0	90,0	215,0	8
1376385	2360-0149	23,0	23,0	18,0	107,0	90,0	215,0	8
1179091	2360-0151	25,0	25,0	20,0	115,0	90,0	231,0	8
105842	2360-0152	26,0	26,0	20,0	115,0	90,0	231,0	8
1108750	2360-0153	27,0	27,0	22,4	124,0	100,0	247,0	8
1267132	2360-0155	30,0	30,0	22,4	124,0	100,0	247,0	10
1293027	2360-0156	32,0	32,0	25,0	133,0	110,0	265,0	10
1584323	2360-0157	34,0	34,0	28,0	142,0	120,0	284,0	10
1376390	2360-0158	35,0	35,0	28,0	142,0	120,0	284,0	10
105903	2360-0159	36,0	36,0	28,0	142,0	120,0	284,0	10
1376393	2360-0161	38,0	38,0	31,5	152,0	125,0	305,0	12
1179093	2360-0162	40,0	40,0	31,5	152,0	125,0	305,0	12
1181232	2360-0165	45,0	45,0	35,5	163,0	130,0	326,0	12
1179096	2360-0169	50,0	50,0	40,0	174,0	135,0	347,0	12
1179099	2360-0171	55,0	55,0	45,0	184,0	145,0	367,0	12
1179102	2360-0174	60,0	60,0	45,0	184,0	145,0	367,0	12

Развёртки ручные цилиндрические

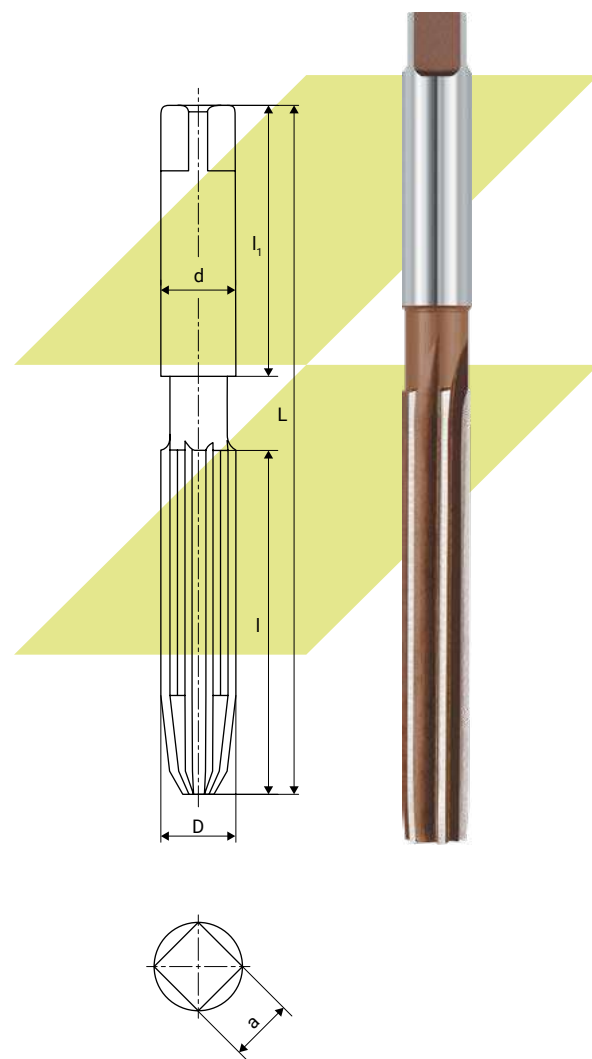
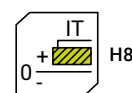
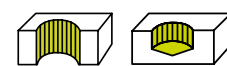

Артикул	Обозначение по ГОСТ	D, мм	d, мм	a, мм	I, мм	I ₁ , мм	L, мм	Z, шт
1177898	2360-0112	3,0	3,0	2,50	31,0	28,0	62,0	6
1425553	—	3,3	3,3	2,50	31,0	28,0	62,0	6
1425556	2360-0114	3,4	3,4	2,80	31,0	28,0	62,0	6
105537	2360-0115	3,5	3,5	2,80	35,0	32,0	71,0	6
1425559	2360-0116	3,6	3,6	2,80	35,0	32,0	71,0	6
1425562	2360-0117	3,8	3,8	3,15	35,0	32,0	71,0	6
1177901	2360-0118	4,0	4,0	3,15	38,0	32,0	76,0	6
1425565	2360-0119	4,2	4,2	3,15	38,0	32,0	76,0	6

Артикул	Обозначение по ГОСТ	D, мм	d, мм	a, мм	I, мм	I ₁ , мм	L, мм	Z, шт
105563	2360-0120	4,5	4,5	3,55	41,0	32,0	81,0	6
1150816	2360-0121	4,8	4,8	4,00	41,0	32,0	81,0	6
1177904	2360-0122	5,0	5,0	4,00	44,0	36,0	87,0	6
1425569	2360-0123	5,2	5,2	4,00	44,0	36,0	87,0	6
1584320	2360-0124	5,5	5,5	4,50	47,0	40,0	93,0	6
1177907	2360-0125	6,0	6,0	5,00	47,0	40,0	93,0	6
1425571	2360-0126	6,3	6,3	5,00	47,0	40,0	93,0	6
1220035	2360-0127	6,5	6,5	5,00	47,0	40,0	93,0	6
1177910	2360-0128	7,0	7,0	5,60	54,0	45,0	107,0	6
1425573	2360-0129	7,5	7,5	5,60	54,0	45,0	107,0	6
1179082	2360-0130	8,0	8,0	6,30	58,0	45,0	115,0	6
1177914	2360-0131	8,5	8,5	6,30	58,0	45,0	115,0	6
105640	2360-0132	9,0	9,0	7,10	62,0	50,0	124,0	6
1425576	2360-0133	9,5	9,5	7,10	62,0	50,0	124,0	6
1179085	2360-0134	10,0	10,0	8,00	66,0	50,0	133,0	6
1177917	2360-0135	10,5	10,5	8,00	66,0	50,0	133,0	8
1376370	2360-0136	11,0	11,0	9,00	71,0	55,0	142,0	8
1177921	2360-0137	11,5	11,5	9,00	71,0	55,0	142,0	8
1179088	2360-0138	12,0	12,0	10,00	76,0	60,0	152,0	8
1376372	2360-0139	13,0	13,0	10,00	76,0	60,0	152,0	8
1177925	2360-0140	14,0	14,0	11,20	81,0	65,0	163,0	8
1220844	2360-0142	16,0	16,0	12,50	87,0	70,0	175,0	8
1376374	2360-0143	17,0	17,0	12,50	87,0	70,0	175,0	8
1376377	2360-0144	18,0	18,0	14,00	93,0	80,0	188,0	8
1425578	2360-0145	19,0	19,0	14,00	93,0	80,0	188,0	8
1261547	2360-0146	20,0	20,0	16,00	100,0	80,0	201,0	8
1376381	2360-0147	21,0	21,0	16,00	100,0	80,0	201,0	8
1261548	2360-0148	22,0	22,0	18,00	107,0	90,0	215,0	8
1376387	2360-0149	23,0	23,0	18,00	107,0	90,0	215,0	8
105824	2360-0150	24,0	24,0	20,00	115,0	90,0	231,0	8
1177928	2360-0151	25,0	25,0	20,00	115,0	90,0	231,0	8
105843	2360-0152	26,0	26,0	20,00	115,0	90,0	231,0	8
105848	2360-0153	27,0	27,0	22,40	124,0	100,0	247,0	8
105862	2360-0154	28,0	28,0	22,40	124,0	100,0	247,0	8
1267133	2360-0155	30,0	30,0	22,40	124,0	100,0	247,0	10
1376388	2360-0156	32,0	32,0	25,00	133,0	110,0	265,0	10
105885	2360-0157	34,0	34,0	28,00	142,0	120,0	284,0	10
1376391	2360-0158	35,0	35,0	28,00	142,0	120,0	284,0	10
105904	2360-0159	36,0	36,0	28,00	142,0	120,0	284,0	10

Артикул	Обозначение по ГОСТ	D, мм	d, мм	a, мм	l, мм	l ₁ , мм	L, мм	Z, шт
1123894	2360-0160	37,0	37,0	28,00	152,0	125,0	305,0	12
1376394	2360-0161	38,0	38,0	31,50	152,0	125,0	305,0	12
1179094	2360-0162	40,0	40,0	31,50	152,0	125,0	305,0	12
1181233	2360-0165	45,0	45,0	35,50	163,0	130,0	326,0	12
1179097	2360-0169	50,0	50,0	40,00	174,0	135,0	347,0	12
1179100	2360-0171	55,0	55,0	45,00	184,0	145,0	367,0	12
1179103	2360-0174	60,0	60,0	45,00	184,0	145,0	367,0	12

Развёртки ручные цилиндрические

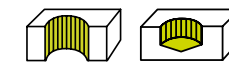

ГОСТ 7722-77

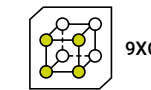

9XC

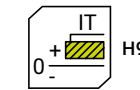

IT H9



Прямая



Ручная

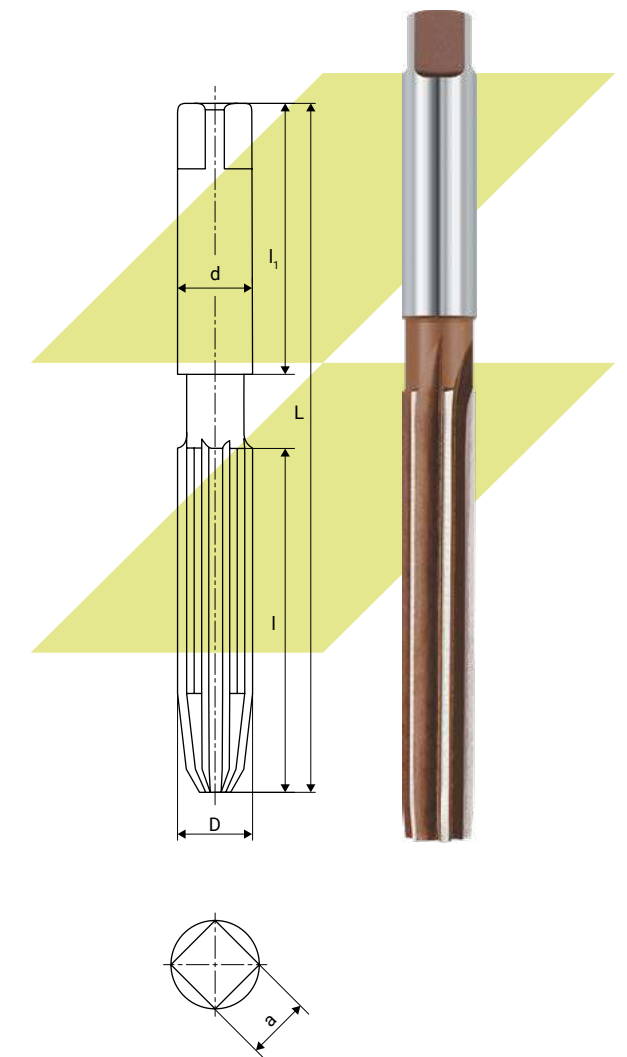

Артикул	Обозначение по ГОСТ	D, мм	d, мм	a, мм	l, мм	l ₁ , мм	L, мм	Z, шт
1177899	2360-0112	3,0	3,0	2,50	31,0	28,0	62,0	6
1425554	—	3,3	3,3	2,50	31,0	28,0	62,0	6
1425557	2360-0114	3,4	3,4	2,80	31,0	28,0	62,0	6
1220032	2360-0115	3,5	3,5	2,80	35,0	32,0	71,0	6
1425560	2360-0116	3,6	3,6	2,80	35,0	32,0	71,0	6
1425563	2360-0117	3,8	3,8	3,15	35,0	32,0	71,0	6
1177902	2360-0118	4,0	4,0	3,15	38,0	32,0	76,0	6
1425566	2360-0119	4,2	4,2	3,15	38,0	32,0	76,0	6

Артикул		Обозначение по ГОСТ	D, мм	d, мм	a, мм	l, мм	l ₁ , мм	L, мм	Z, шт
105564	●	2360-0120	4,5	4,5	3,55	41,0	32,0	81,0	6
1265361	●	2360-0121	4,8	4,8	4,00	41,0	32,0	81,0	6
1177905	●	2360-0122	5,0	5,0	4,00	44,0	36,0	87,0	6
1425570	●	2360-0123	5,2	5,2	4,00	44,0	36,0	87,0	6
1584321	●	2360-0124	5,5	5,5	4,50	47,0	40,0	93,0	6
1177908	●	2360-0125	6,0	6,0	5,00	47,0	40,0	93,0	6
1425572	●	2360-0126	6,3	6,3	5,00	47,0	40,0	93,0	6
1220036	●	2360-0127	6,5	6,5	5,00	47,0	40,0	93,0	6
1234644	●	—	6,8	6,8	5,60	54,0	45,0	107,0	6
1177911	●	2360-0128	7,0	7,0	5,60	54,0	45,0	107,0	6
1425574	●	2360-0129	7,5	7,5	5,60	54,0	45,0	107,0	6
1179083	●	2360-0130	8,0	8,0	6,30	58,0	45,0	115,0	6
1177915	●	2360-0131	8,5	8,5	6,30	58,0	45,0	115,0	6
1240752	●	2360-0132	9,0	9,0	7,10	62,0	50,0	124,0	6
1425577	●	2360-0133	9,5	9,5	7,10	62,0	50,0	124,0	6
1179086	●	2360-0134	10,0	10,0	8,00	66,0	50,0	133,0	6
1177918	●	2360-0135	10,5	10,5	8,00	66,0	50,0	133,0	8
1376371	●	2360-0136	11,0	11,0	9,00	71,0	55,0	142,0	8
1177922	●	2360-0137	11,5	11,5	9,00	71,0	55,0	142,0	8
1179089	●	2360-0138	12,0	12,0	10,00	76,0	60,0	152,0	8
1289654	●	—	12,5	12,5	10,00	76,0	60,0	152,0	8
1177923	●	2360-0139	13,0	13,0	10,00	76,0	60,0	152,0	8
1177926	●	2360-0140	14,0	14,0	11,20	81,0	65,0	163,0	8
1220842	●	2360-0140	15,0	15,0	11,20	81,0	65,0	163,0	8
1220845	●	2360-0142	16,0	16,0	12,50	87,0	70,0	175,0	8
1376375	●	2360-0143	17,0	17,0	12,50	87,0	70,0	175,0	8
1376378	●	2360-0144	18,0	18,0	14,00	93,0	80,0	188,0	8
1425579	●	2360-0145	19,0	19,0	14,00	93,0	80,0	188,0	8
1376379	●	2360-0146	20,0	20,0	16,00	100,0	80,0	201,0	8
1376382	●	2360-0147	21,0	21,0	16,00	100,0	80,0	201,0	8
1376384	●	2360-0148	22,0	22,0	18,00	107,0	90,0	215,0	8
1376386	●	2360-0149	23,0	23,0	18,00	107,0	90,0	215,0	8
105826	●	2360-0150	24,0	24,0	20,00	115,0	90,0	231,0	8
1177929	●	2360-0151	25,0	25,0	20,00	115,0	90,0	231,0	8
105844	●	2360-0152	26,0	26,0	20,00	115,0	90,0	231,0	8
118753	●	2360-0153	27,0	27,0	22,40	124,0	100,0	247,0	8
105863	○	2360-0154	28,0	28,0	22,40	124,0	100,0	247,0	8
1272010	●	—	29,0	29,0	22,40	124,0	100,0	247,0	8
1267134	●	2360-0155	30,0	30,0	22,40	124,0	100,0	247,0	10

Артикул		Обозначение по ГОСТ	D, мм	d, мм	a, мм	l, мм	l ₁ , мм	L, мм	Z, шт
1376389	●	2360-0156	32,0	32,0	25,00	133,0	110,0	265,0	10
105886	○	2360-0157	34,0	34,0	28,00	142,0	120,0	284,0	10
1376392	●	2360-0158	35,0	35,0	28,00	142,0	120,0	284,0	10
105905	○	2360-0159	36,0	36,0	28,00	142,0	120,0	284,0	10
1136187	○	2360-0160	37,0	37,0	28,00	152,0	125,0	305,0	12
1376395	●	2360-0161	38,0	38,0	31,50	152,0	125,0	305,0	12
1179095	●	2360-0162	40,0	40,0	31,50	152,0	125,0	305,0	12
1181234	●	2360-0165	45,0	45,0	35,50	163,0	130,0	326,0	12
1179098	●	2360-0169	50,0	50,0	40,00	174,0	135,0	347,0	12
1179101	●	2360-0171	55,0	55,0	45,00	184,0	145,0	367,0	12
1179104	●	2360-0174	60,0	60,0	45,00	184,0	145,0	367,0	12

Развёртки ручные цилиндрические

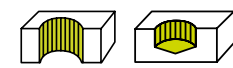

ГОСТ
7722-77



9XC

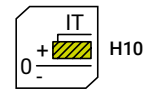

IT
H10



Прямая



Ручная

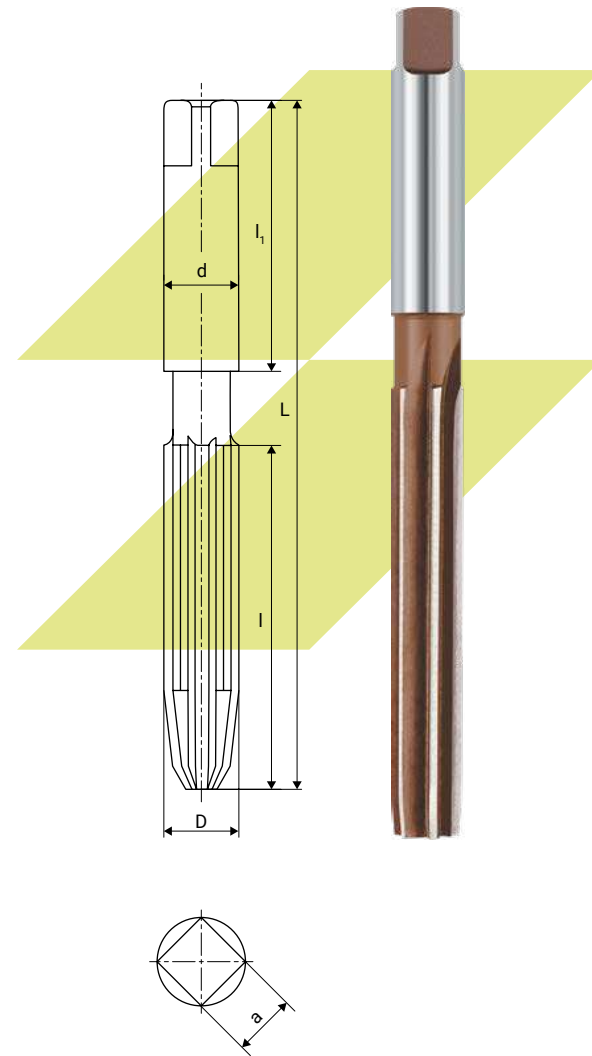

Артикул	Обозначение по ГОСТ	D, мм	d, мм	a, мм	I, мм	I ₁ , мм	L, мм	Z, шт
1175966	2360-0107	1,8	1,8	1,40	23,0	20,0	47,0	4
1264157	—	2,3	2,3	1,80	27,0	22,0	54,0	4
1185067	2360-0112	3,0	3,0	2,50	31,0	28,0	62,0	6
1185068	2360-0118	4,0	4,0	3,15	38,0	32,0	76,0	6
1185069	2360-0122	5,0	5,0	4,00	44,0	36,0	87,0	6
1185070	2360-0125	6,0	6,0	5,00	47,0	40,0	93,0	6
1185071	2360-0128	7,0	7,0	5,60	54,0	45,0	107,0	6
1185072	2360-0130	8,0	8,0	6,30	58,0	45,0	115,0	6

Артикул	Обозначение по ГОСТ	D, мм	d, мм	a, мм	I, мм	I ₁ , мм	L, мм	Z, шт
1185073	2360-0132	9,0	9,0	7,10	62,0	50,0	124,0	6
1185074	2360-0134	10,0	10,0	8,00	66,0	50,0	133,0	6
1185075	2360-0136	11,0	11,0	9,00	71,0	55,0	142,0	8
1185076	2360-0138	12,0	12,0	10,00	76,0	60,0	152,0	8
1289655	—	12,5	12,5	10,00	76,0	60,0	152,0	8
1185077	2360-0139	13,0	13,0	10,00	76,0	60,0	152,0	8
1185078	2360-0140	14,0	14,0	11,20	81,0	65,0	163,0	8
1185079	2360-0140	15,0	15,0	11,20	81,0	65,0	163,0	8
1185080	2360-0142	16,0	16,0	12,50	87,0	70,0	175,0	8
1185081	2360-0143	17,0	17,0	12,50	87,0	70,0	175,0	8
1185082	2360-0144	18,0	18,0	14,00	93,0	80,0	188,0	8
1185083	2360-0145	20,0	20,0	16,00	100,0	80,0	201,0	8
1257810	2360-0148	22,0	22,0	18,00	107,0	90,0	215,0	8
1242945	2360-0149	23,0	23,0	18,00	107,0	90,0	215,0	8

Развёртки ручные цилиндрические

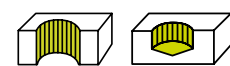

ГОСТ
7722-77



P6M5

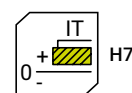

IT
H7



Прямая



Ручная

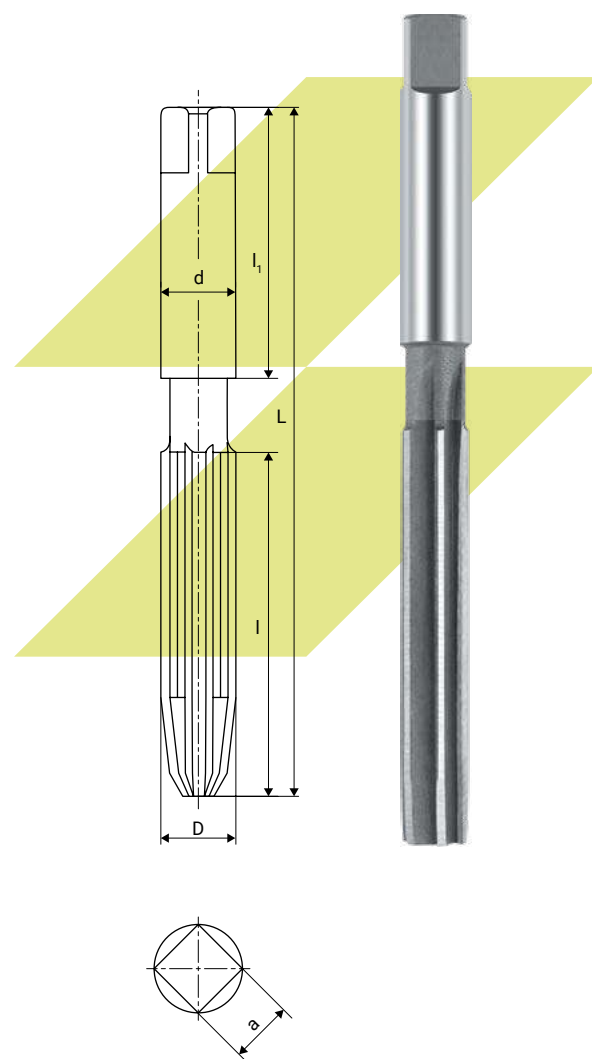

Артикул	Обозначение по ГОСТ	D, мм	d, мм	a, мм	l, мм	l ₁ , мм	L, мм	Z, шт
1175951	2360-0101	1,00	2,00	1,60	18,0	18,0	38,0	5
1441284	2360-0102	1,10	2,00	1,60	18,0	18,0	38,0	5
1175954	2360-0103	1,20	2,00	1,60	20,0	18,0	41,0	5
1175957	2360-0104	1,40	2,00	1,60	20,0	18,0	41,0	5
1480573	2360-0105	1,50	1,50	1,25	20,0	18,0	41,0	4
1175960	2360-0106	1,60	1,60	1,25	21,0	20,0	44,0	4
1175963	2360-0107	1,80	1,80	1,40	23,0	20,0	47,0	4
1284877	—	1,98	2,00	1,60	25,0	22,0	50,0	4

Артикул	Обозначение по ГОСТ	D, мм	d, мм	a, мм	l, мм	l ₁ , мм	L, мм	Z, шт
1175967	2360-0108	2,00	2,00	1,60	25,0	22,0	50,0	4
1175970	2360-0109	2,20	2,20	1,80	27,0	22,0	54,0	4
1175974	2360-0110	2,50	2,50	2,00	29,0	25,0	58,0	4
1178566	2360-0111	2,80	2,80	2,24	31,0	28,0	62,0	4
1284879	—	2,98	2,98	2,24	31,0	28,0	62,0	4
1177897	2360-0112	3,00	3,00	2,50	31,0	28,0	62,0	6
1178567	2360-0113	3,20	3,20	2,50	31,0	28,0	62,0	6
1177900	2360-0118	4,00	4,00	3,15	38,0	32,0	76,0	6
1177903	2360-0122	5,00	5,00	4,00	44,0	36,0	87,0	6
1177906	2360-0125	6,00	6,00	5,00	47,0	40,0	93,0	6
1177909	2360-0128	7,00	7,00	5,60	54,0	45,0	107,0	6
1177912	2360-0130	8,00	8,00	6,30	58,0	45,0	115,0	6
1254684	2360-0132	9,00	9,00	7,10	62,0	50,0	124,0	6
1178568	2360-0134	10,00	10,00	8,00	66,0	50,0	133,0	6
1254685	2360-0136	11,00	11,00	9,00	71,0	55,0	142,0	8
1178569	2360-0138	12,00	12,00	10,00	76,0	60,0	152,0	8
1254686	2360-0139	13,00	13,00	10,00	76,0	60,0	152,0	8
1178570	—	13,50	13,50	11,20	81,0	65,0	163,0	8
1177924	2360-0140	14,00	14,00	11,20	81,0	65,0	163,0	8
1178571	—	14,80	14,80	11,20	81,0	65,0	163,0	8
1178572	2360-0140	15,00	15,00	11,20	81,0	65,0	163,0	8
1178573	2360-0142	16,00	16,00	12,50	87,0	70,0	175,0	8
1254687	2360-0143	17,00	17,00	12,50	87,0	70,0	175,0	8
1178574	2360-0144	18,00	18,00	14,00	93,0	80,0	188,0	8
1254688	2360-0145	19,00	19,00	14,00	93,0	80,0	188,0	8
1254689	2360-0146	20,00	20,00	16,00	100,0	80,0	201,0	8
1177927	2360-0151	25,00	25,00	20,00	115,0	90,0	231,0	8
1178575	2360-0153	27,00	27,00	22,40	124,0	100,0	247,0	8
1178576	2360-0155	30,00	30,00	22,40	124,0	100,0	247,0	10

Развёртки ручные цилиндрические

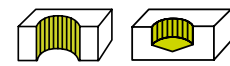

ГОСТ
7722-77



P6M5

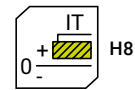

IT
H8



Прямая



Ручная

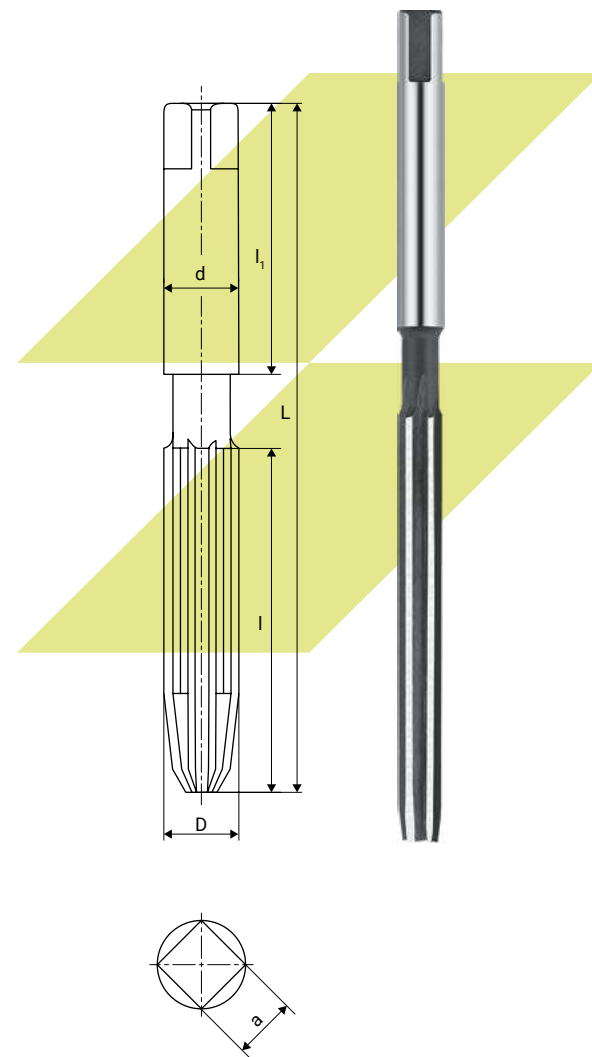

Артикул	Обозначение по ГОСТ	D, мм	d, мм	a, мм	l, мм	l ₁ , мм	L, мм	Z, шт
1175952	2360-0101	1,0	2,0	1,60	18,0	18,0	38,0	5
1175955	2360-0103	1,2	2,0	1,60	20,0	18,0	41,0	5
1175958	2360-0104	1,4	2,0	1,60	20,0	18,0	41,0	5
1480574	2360-0105	1,5	1,5	1,25	20,0	18,0	41,0	4
1175961	2360-0106	1,6	1,6	1,25	21,0	20,0	44,0	4
1175964	2360-0107	1,8	1,8	1,40	23,0	20,0	47,0	4
1175968	2360-0108	2,0	2,0	1,60	25,0	22,0	50,0	4
1175971	2360-0109	2,2	2,2	1,80	27,0	22,0	54,0	4

Артикул	Обозначение по ГОСТ	D, мм	d, мм	a, мм	l, мм	l ₁ , мм	L, мм	Z, шт
1175975	2360-0110	2,5	2,5	2,00	29,0	25,0	58,0	4
1480608	2360-0111	2,8	2,8	2,24	31,0	28,0	62,0	4
1330978	2360-0112	3,0	3,0	2,50	31,0	28,0	62,0	6
1261544	2360-0113	3,2	3,2	2,50	31,0	28,0	62,0	6
1264160	2360-0118	4,0	4,0	3,15	38,0	32,0	76,0	6

Развёртки ручные цилиндрические

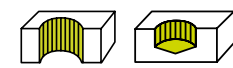

ГОСТ
7722-77



P6M5

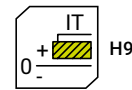

IT
H9



Прямая



Ручная

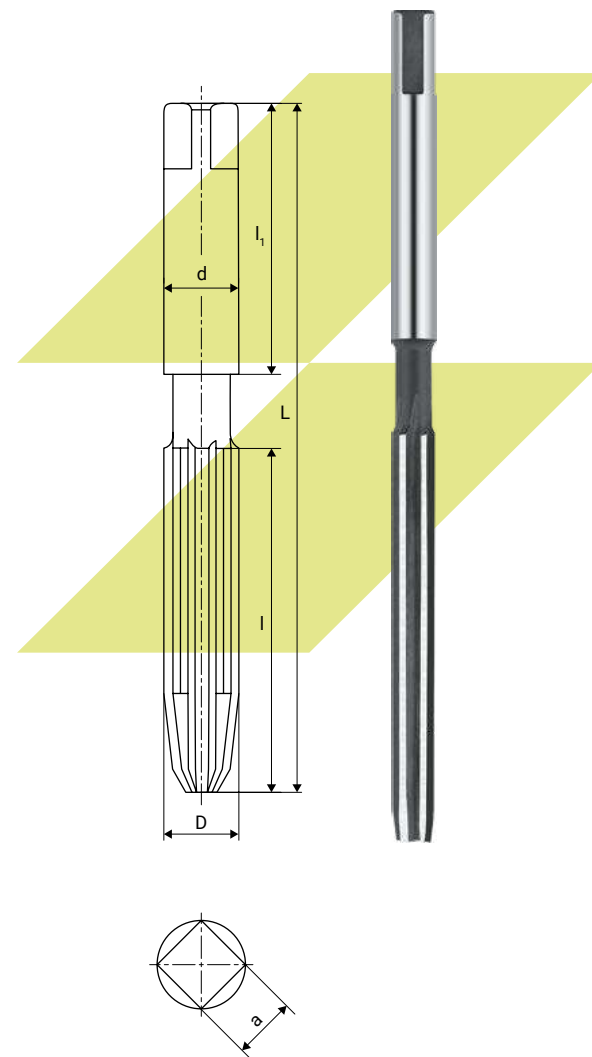

Артикул	Обозначение по ГОСТ	D, мм	d, мм	a, мм	l, мм	l ₁ , мм	L, мм	Z, шт
1175953	2360-0101	1,0	2,0	1,60	18,0	18,0	38,0	5
1175956	2360-0103	1,2	2,0	1,60	20,0	18,0	41,0	5
1284876	—	1,3	2,0	1,60	20,0	18,0	41,0	5
1175959	2360-0104	1,4	2,0	1,60	20,0	18,0	41,0	5
1480575	2360-0105	1,5	1,5	1,25	20,0	18,0	41,0	4
1175962	2360-0106	1,6	1,6	1,25	21,0	20,0	44,0	4
1175965	2360-0107	1,8	1,8	1,40	23,0	20,0	47,0	4
1175969	2360-0108	2,0	2,0	1,60	25,0	22,0	50,0	4

Артикул	Обозначение по ГОСТ	D, мм	d, мм	a, мм	l, мм	l ₁ , мм	L, мм	Z, шт
1175972	2360-0109	2,2	2,2	1,80	27,0	22,0	54,0	4
1175976	2360-0110	2,5	2,5	2,00	29,0	25,0	58,0	4
1376369	2360-0111	2,8	2,8	2,24	31,0	28,0	62,0	4
1261545	2360-0113	3,2	3,2	2,50	31,0	28,0	62,0	6

Развёртки ручные конические конусностью 1:30 с цилиндрическим хвостовиком

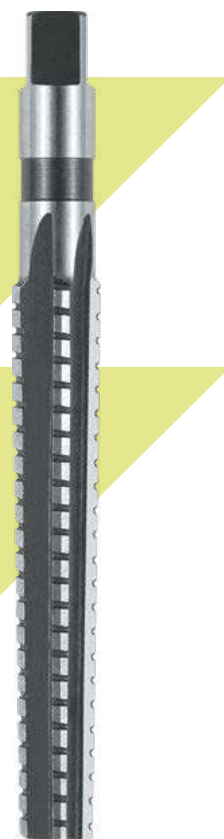
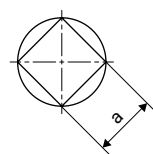
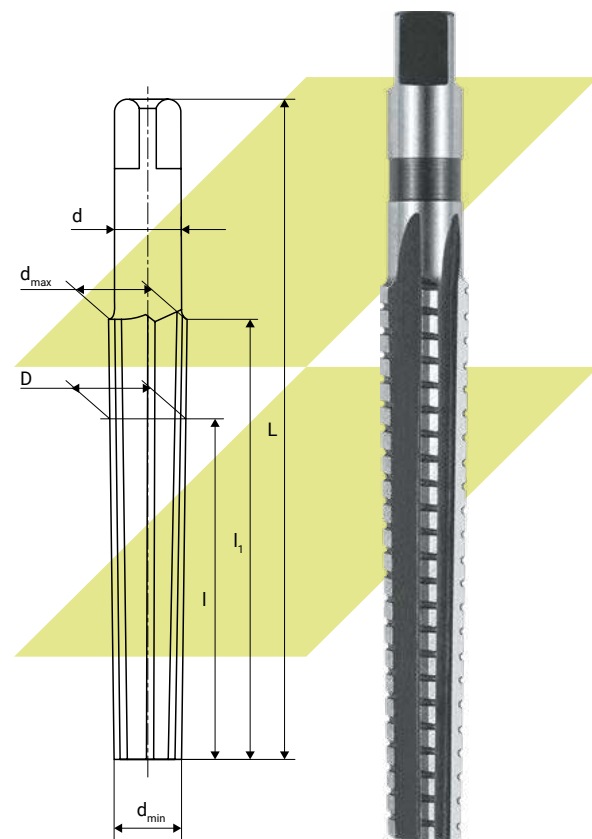
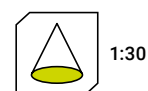
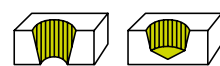

Артикул	Обозначение по ГОСТ	D, мм	D _{min} ', мм	d _{max} ', мм	d, мм	a, мм	l, мм	l ₁ , мм	L, мм	Z, шт	Квалитет
1417033	2372-0101-1	13,0	10,9	13,6	11,2	9,0	62,0	80,0	120,0	5	предварительная
105098	2372-0101	13,0	10,9	13,6	11,2	9,0	62,0	80,0	120,0	7	чистовая
105102	2372-0102-1	16,0	13,6	16,6	14,0	11,2	72,0	90,0	130,0	5	предварительная
105103	2372-0102	16,0	13,6	16,6	14,0	11,2	72,0	90,0	130,0	7	чистовая
105106	2372-0103-1	19,0	16,2	19,6	16,0	12,5	84,0	102,0	150,0	5	предварительная
105107	2372-0103	19,0	16,2	19,6	16,0	12,5	84,0	102,0	150,0	7	чистовая
105112	2372-0104	22,0	18,9	22,8	20,0	16,0	93,0	117,0	170,0	9	чистовая
105114	2372-0105-1	27,0	23,5	27,8	22,4	18,0	105,0	129,0	190,0	7	предварительная

Артикул	Обозначение по ГОСТ	D, мм	D _{min} ', мм	d _{max} ', мм	d, мм	a, мм	l, мм	l ₁ , мм	L, мм	Z, шт	Квалитет
105115	2372-0105	27,0	23,5	27,8	22,4	18,0	105,0	129,0	190,0	9	чистовая
105117	2372-0106-1	32,0	28,2	32,8	25,0	20,0	114,0	138,0	200,0	7	предварительная
105118	2372-0106	32,0	28,2	32,8	25,0	20,0	114,0	138,0	200,0	9	чистовая
105119	2372-0107-1	40,0	35,8	41,0	35,5	28,0	126,0	158,0	225,0	9	предварительная
105121	2372-0107	40,0	35,8	41,0	35,5	28,0	126,0	158,0	225,0	11	чистовая
105122	2372-0108	50,0	45,4	51,0	40,0	31,5	138,0	168,0	250,0	11	чистовая

Развёртки ручные конические конусностью 1:50 с цилиндрическим хвостовиком

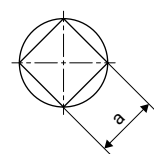
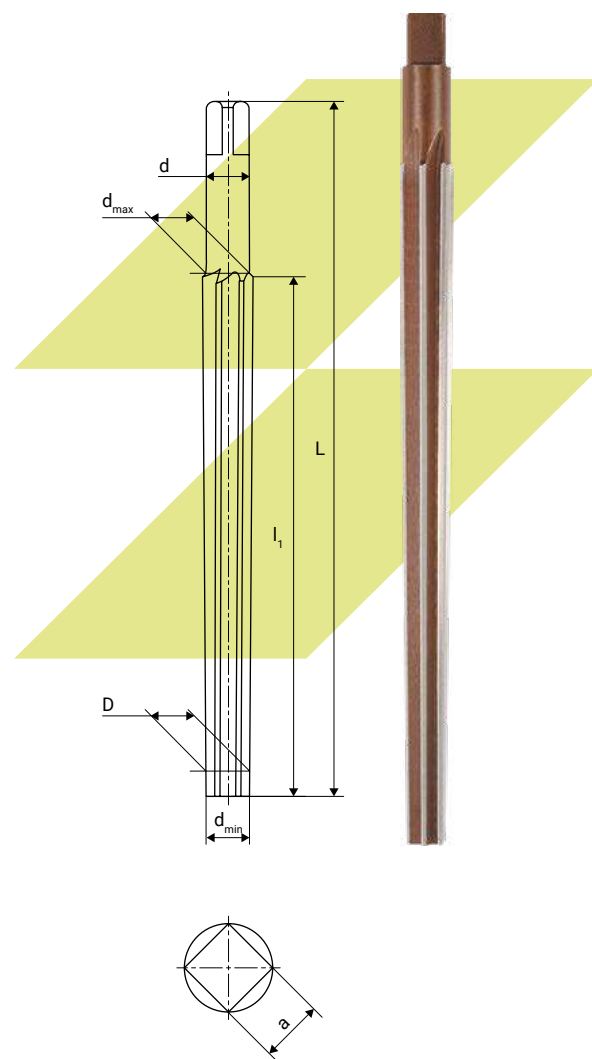
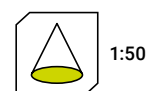
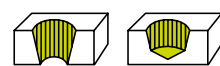

Артикул	Обозначение по ГОСТ	D, мм	D _{min'} , мм	D _{max'} , мм	d, мм	a, мм	l ₁ , мм	L, мм	Z шт
1256728	—	3,0	2,9	4,06	4,0	2,5	40,0	65,0	5
1292737	2372-0005	3,0	2,9	4,06	4,0	2,5	58,0	80,0	5
1256729	—	4,0	3,9	5,26	5,0	3,2	50,0	80,0	5
1292738	2372-0007	4,0	3,9	5,26	5,0	3,2	68,0	93,0	5
1240351	—	5,0	4,9	6,20	6,3	4,0	60,0	85,0	5
1292739	2372-0009	5,0	4,9	6,20	6,3	4,0	73,0	100,0	5
1179893	—	8,0	7,9	10,80	10,0	6,3	95,0	125,0	7
1292741	2372-0013	8,0	7,9	10,80	10,0	6,3	145,0	180,0	7

Артикул	Обозначение по ГОСТ	D, мм	D _{min'} , мм	D _{max'} , мм	d, мм	a, мм	l ₁ , мм	L, мм	Z шт
1179894	—	10,0	9,9	13,40	12,5	8,0	120,0	155,0	7
1292742	2372-0015	10,0	9,9	13,40	12,5	8,0	175,0	215,0	7
1179895	—	12,0	11,8	16,00	14,0	10,0	140,0	180,0	7
1292743	2372-0033	12,0	11,8	16,00	14,0	10,0	210,0	255,0	7
1179896	—	13,0	12,8	17,20	16,0	10,0	140,0	180,0	7
1292744	—	13,0	12,8	17,20	16,0	10,0	210,0	255,0	7
1584312	2372-0019	16,0	15,8	20,40	18,0	12,5	230,0	280,0	7
1584313	2372-0021	20,0	19,8	24,80	22,4	16,0	250,0	310,0	7
1337839	2372-0023	25,0	24,7	30,70	28,0	20,0	300,0	370,0	7
1179898	—	30,0	29,7	36,10	31,5	22,4	190,0	250,0	9
1292746	2372-0203	30,0	29,7	36,10	31,5	22,4	320,0	400,0	9
1179899	—	32,0	31,7	38,10	31,5	25,0	190,0	250,0	9
1292747	2372-0025	32,0	31,7	38,10	31,5	25,0	320,0	400,0	9
1179900	—	40,0	39,7	46,50	40,0	31,5	210,0	260,0	9
1292748	2372-0027	40,0	39,7	46,50	40,0	31,5	340,0	430,0	9
1179901	—	50,0	49,7	56,90	50,0	40,0	220,0	300,0	9
1292749	2372-0029	50,0	49,7	56,90	50,0	40,0	360,0	460,0	9

Развёртки ручные конические конусностью 1:50 с цилиндрическим хвостовиком

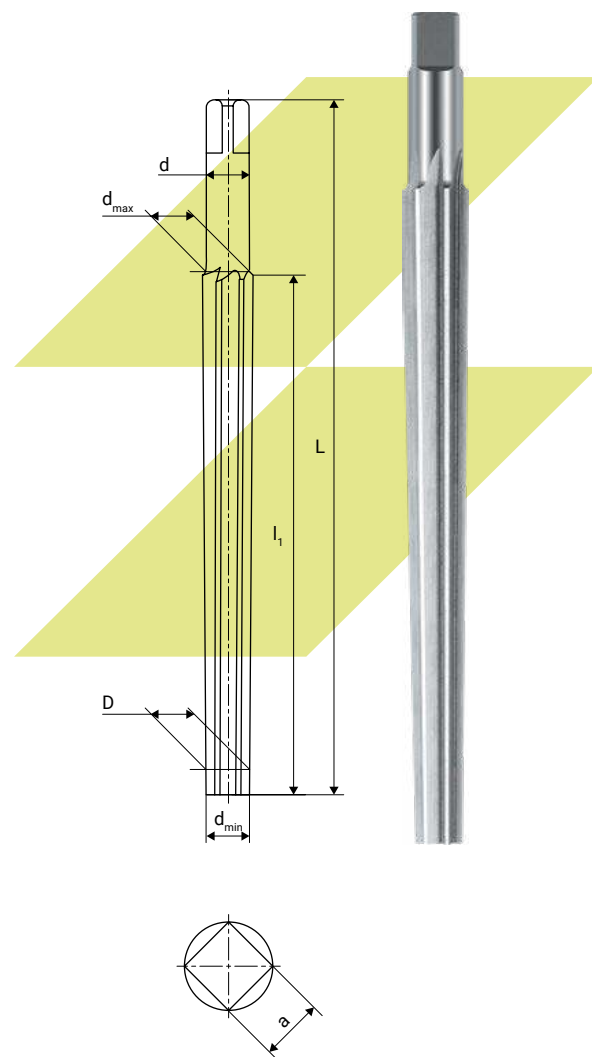
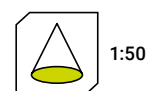
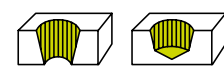

Артикул	Обозначение по ГОСТ	D, мм	D _{min'} , мм	D _{max'} , мм	d, мм	a, мм	l, мм	L, мм	Z шт
1175946	2372-0001	1,0	0,9	1,46	3,15	1,60	28,0	46,0	3
1175947	2372-0031	1,2	1,1	1,74	3,15	1,60	32,0	50,0	3
1220075	—	1,4	1,3	2,00	3,15	1,60	37,0	57,0	3
1175948	2372-0032	1,6	1,5	2,26	3,15	1,25	38,0	58,0	3
1220076	—	1,8	1,7	2,86	3,15	1,40	33,0	65,0	3
1175949	2372-0003	2,0	1,9	2,86	3,15	1,60	48,0	68,0	3
1175950	2372-0004	2,5	2,4	3,36	3,15	2,00	48,0	68,0	3
1220040	2372-0005	3,0	2,9	4,06	4,00	2,50	58,0	80,0	5

Артикул	Обозначение по ГОСТ	D, мм	D _{min'} , мм	D _{max'} , мм	d, мм	a, мм	l, мм	L, мм	Z шт
1220041	2372-0009	5,0	4,9	6,36	6,30	4,00	73,0	100,0	5
1220043	2372-0013	8,0	7,9	10,80	10,00	6,30	145,0	180,0	7
1220044	2372-0015	10,0	9,9	13,40	12,50	8,00	175,0	215,0	7
1220045	2372-0033	12,0	11,8	16,00	14,00	10,00	210,0	255,0	7

Развёртки конические с цилиндрическим хвостовиком под Конусы Морзе

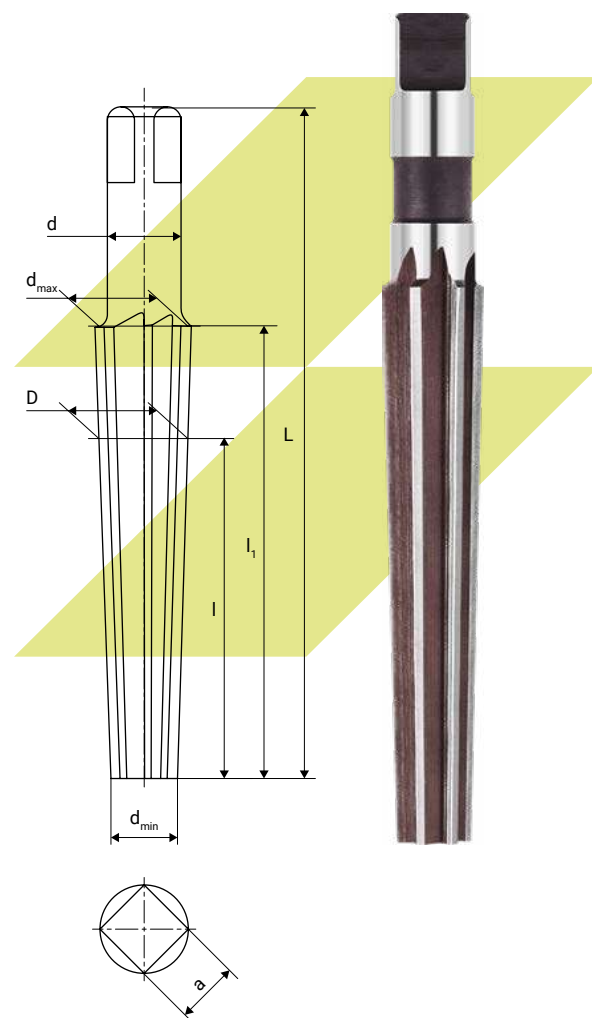
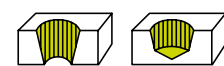

Артикул	Обозначение по ГОСТ	D, мм	D _{min} ^г , мм	D _{max} ^г , мм	Конусы Морзе	d, мм	a, мм	l, мм	l ₁ , мм	L, мм	Z, шт	Квалитет
105434	2372-0132-1	9,045	6,547	9,722	0	8,0	6,3	48,0	61,0	93,0	5	предварительная
105435	2372-0132-0	9,045	6,547	9,722	0	8,0	6,3	48,0	61,0	93,0	5	черновая
105436	2372-0132	9,045	6,547	9,722	0	8,0	6,3	48,0	61,0	93,0	6	чистовая
105437	2372-0133-1	12,065	9,571	12,863	1	10,0	8,0	50,0	66,0	102,0	5	предварительная
105439	2372-0133	12,065	9,571	12,863	1	10,0	8,0	50,0	66,0	102,0	7	чистовая
105441	2372-0134-1	17,780	14,733	18,679	2	14,0	11,2	61,0	79,0	121,0	5	предварительная
105443	2372-0134	17,780	14,733	18,679	2	14,0	11,2	61,0	79,0	121,0	7	чистовая
105445	2372-0135-1	23,825	20,010	24,829	3	20,0	16,0	76,0	96,0	146,0	7	предварительная

Артикул	Обозначение по ГОСТ	D, мм	D _{min} ^г , мм	D _{max} ^г , мм	Конусы Морзе	d, мм	a, мм	l, мм	l ₁ , мм	L, мм	Z, шт	Квалитет
105447	2372-0135-0	23,825	20,010	24,829	3	20,0	16,0	76,0	96,0	146,0	7	черновая
105448	2372-0135	23,825	20,010	24,829	3	20,0	16,0	76,0	96,0	146,0	9	чистовая
105449	2372-0136-1	31,267	26,229	32,410	4	25,0	20,0	97,0	119,0	179,0	7	предварительная
105450	2372-0136-0	31,267	26,229	32,410	4	25,0	20,0	97,0	119,0	179,0	7	черновая
105451	2372-0136	31,267	26,229	32,410	4	25,0	20,0	97,0	119,0	179,0	9	чистовая
105452	2372-0137-1	44,399	37,873	45,767	5	31,5	25,0	124,0	150,0	222,0	9	предварительная
115405	2372-0137	44,399	37,873	45,767	5	31,5	25,0	124,0	150,0	222,0	11	чистовая
105455	2372-0138-1	63,348	54,171	64,516	6	45,0	35,5	176,0	208,0	300,0	11	предварительная
105457	2372-0138	63,348	54,171	64,516	6	45,0	35,5	176,0	208,0	300,0	13	чистовая

Развёртки ручные разжимные

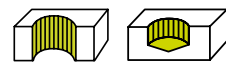

ГОСТ
3509-71



9XC



Прямая



Ручная

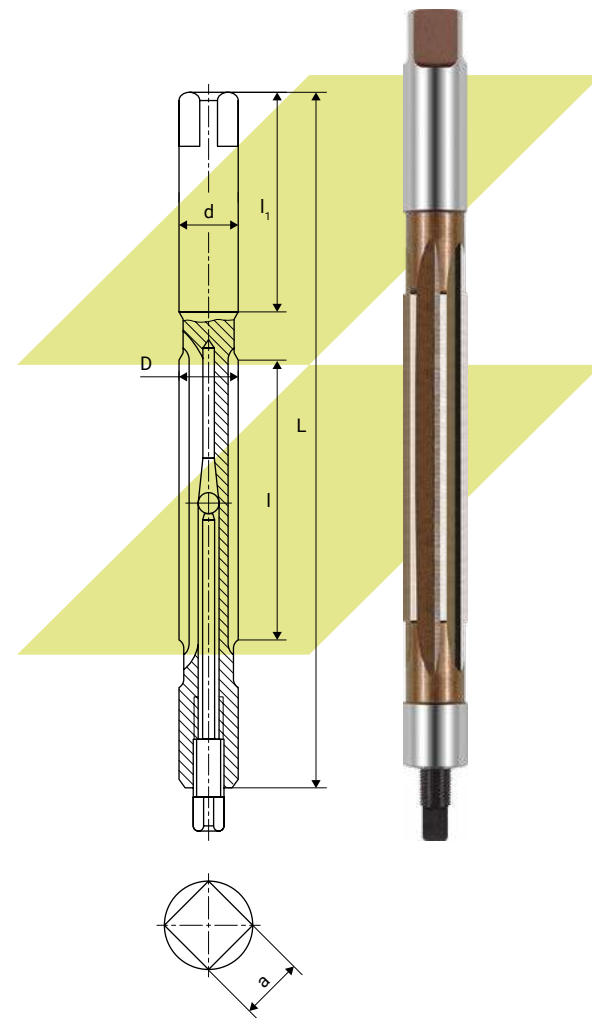

Артикул	Обозначение по ГОСТ	D, мм	d, мм	a, мм	l, мм	l ₁ , мм	L, мм	Z, шт
105477	2362-0005	12,0	12,0	10,0	60,0	38,0	140,0	8
105479	2362-0006	13,0	13,0	10,0	60,0	38,0	140,0	8
105484	2362-0010	17,0	17,0	12,5	70,0	40,0	160,0	8
105485	2362-0011	18,0	18,0	14,0	75,0	45,0	180,0	8
105486	2362-0012	19,0	19,0	14,0	75,0	45,0	180,0	8
105488	2362-0013	20,0	20,0	16,0	85,0	45,0	200,0	8
105492	2362-0016	24,0	24,0	20,0	90,0	50,0	220,0	8
105497	2362-0018	26,0	26,0	20,0	100,0	60,0	240,0	8

Артикул	Обозначение по ГОСТ	D, мм	d, мм	a, мм	l, мм	l ₁ , мм	L, мм	Z, шт
105499	2362-0019	27,0	27,0	22,4	100,0	60,0	240,0	8
105500	2362-0020	28,0	28,0	22,4	110,0	65,0	260,0	8
105502	2362-0021	30,0	30,0	22,4	110,0	65,0	260,0	8
105505	2362-0023	34,0	34,0	28,0	110,0	65,0	260,0	10
105506	2362-0024	36,0	36,0	28,0	125,0	90,0	300,0	10
105510	2362-0027	42,0	42,0	31,5	140,0	100,0	340,0	10

Развёртки ручные регулируемые со вставными ножами

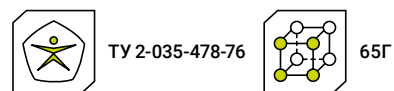
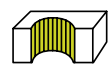

Артикул		D_{\min} мм	D_{\max} мм
1331138	●	10,00	10,75
1331139	●	10,75	11,75
105461	●	19,00	21,00
105462	●	21,00	23,00
105465	●	26,00	29,50
1331142	●	40,00	43,00
1331143	●	43,00	45,00
1331144	●	45,00	47,00
1331145	●	47,00	50,00

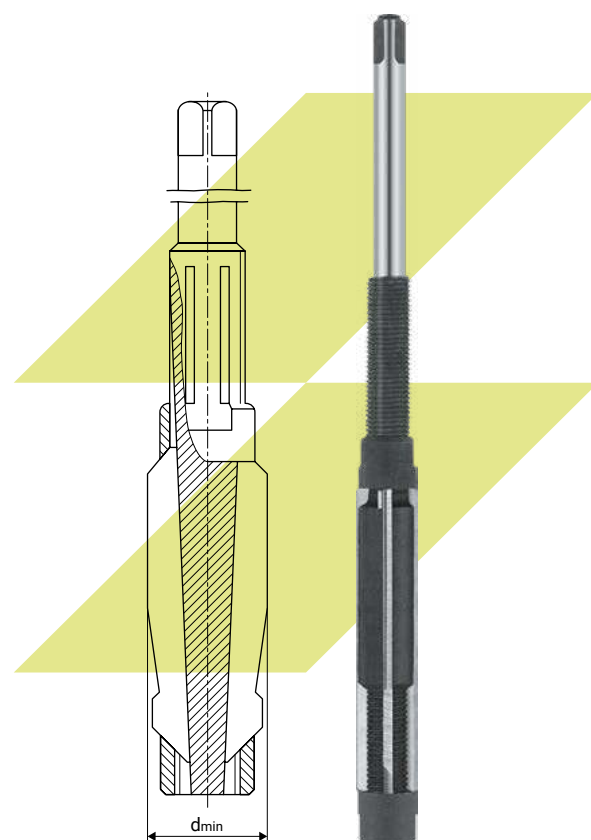

Развёртки машинные цельные с цилиндрическим хвостовиком из твёрдого сплава

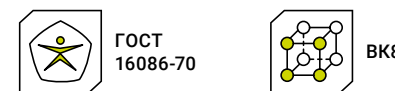
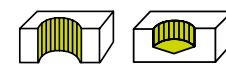

Артикул		Обозначение по ГОСТ	D , мм	d , мм	l , мм	L , мм	Z , шт
1180537	●	—	4,2	4,0	14,0	70,0	4
1379638	●	2363-1103	5,0	5,0	16,0	80,0	4
1379641	●	2363-1127	6,0	6,0	18,0	90,0	4
1379644	●	2363-1187	8,0	8,0	20,0	100,0	4
1109567	●	2363-1199	8,5	8,0	20,0	100,0	4
1379647	●	2363-1235	10,0	9,0	20,0	100,0	4

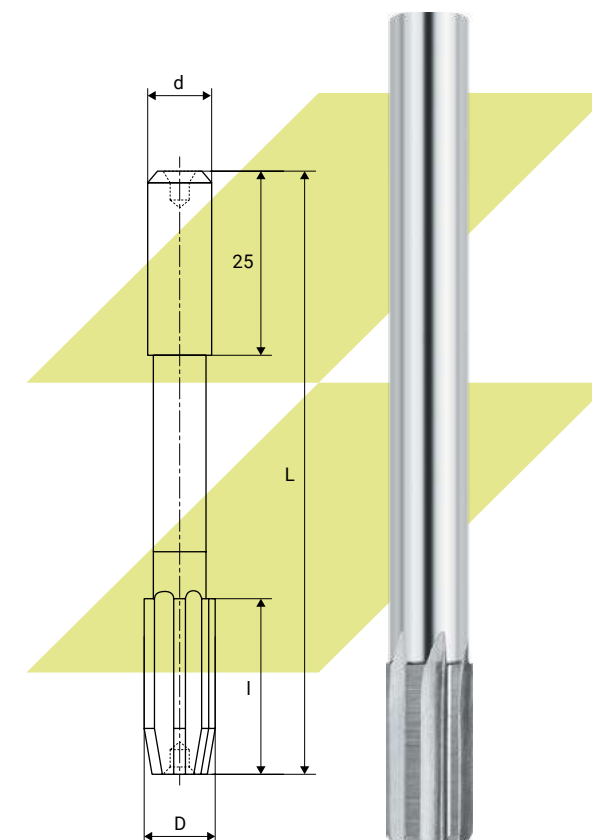

Развёртки машинные цельные с цилиндрическим хвостовиком из твёрдого сплава

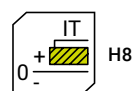
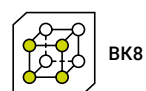
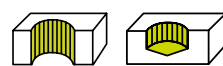

Артикул	Обозначение по ГОСТ	D, мм	d, мм	l, мм	L, мм	l ₁ , мм
1379630	2363-1015	2,0	4,0	12,0	60,0	4
1379631	2363-1019	2,5	5,0	12,0	60,0	4
1379632	2363-1023	3,0	3,0	12,0	60,0	4
1379634	2363-1047	3,5	3,5	14,0	70,0	4
1379636	2363-1071	4,0	4,0	14,0	70,0	4
1379639	2363-1103	5,0	5,0	16,0	80,0	4
1379642	2363-1127	6,0	6,0	18,0	90,0	4
1109565	2363-1175	7,5	7,0	18,0	90,0	4
1379645	2363-1187	8,0	8,0	20,0	100,0	4
1109568	2363-1199	8,5	8,0	20,0	100,0	4
105212	2363-1211	9,0	9,0	20,0	100,0	4
1379648	2363-1235	10,0	9,0	20,0	100,0	4

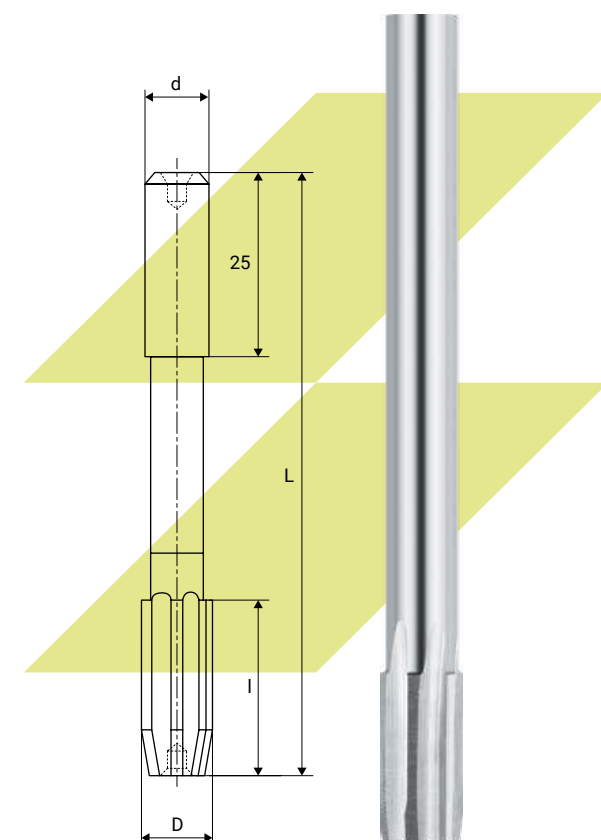

Развёртки машинные цельные с цилиндрическим хвостовиком из твёрдого сплава

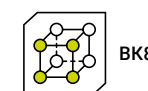
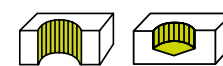

Артикул	Обозначение по ГОСТ	D, мм	d, мм	l, мм	L, мм	Z, шт
1418168	2363-1023	3,0	3,0	12,0	60,0	4
1379633	2363-1031	3,2	3,0	12,0	60,0	4
1379635	2363-1047	3,5	3,5	14,0	70,0	4
1379637	2363-1071	4,0	4,0	14,0	70,0	4
1379640	2363-1103	5,0	5,0	16,0	80,0	4
1379643	2363-1127	6,0	6,0	18,0	90,0	4
1180539	2363-1127	7,0	7,0	18,0	90,0	4
1379646	2363-1163	8,0	8,0	20,0	100,0	4
1180540	2363-1211	9,0	9,0	20,0	100,0	4
1379649	2363-1235	10,0	9,0	20,0	100,0	4

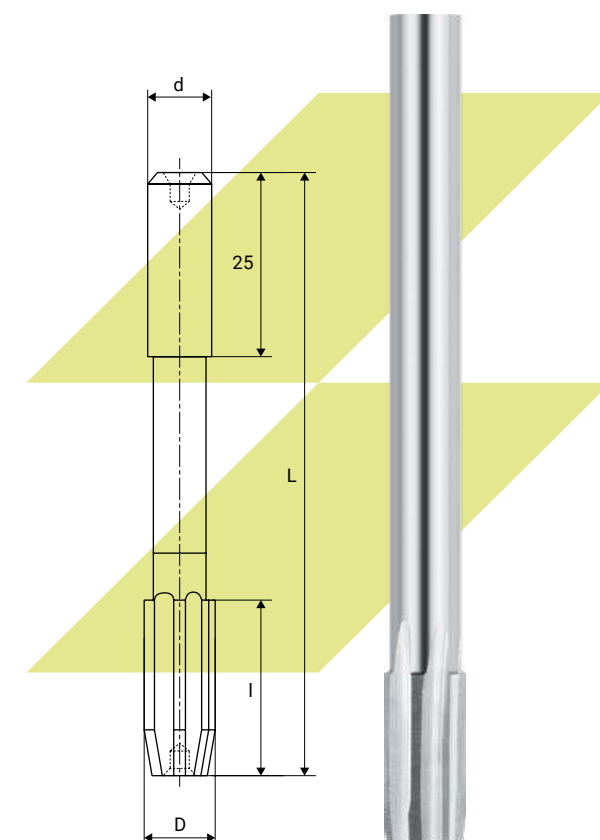

Развёртки машинные, оснащённые твердосплавными напайваемыми пластинами, с коническим хвостовиком

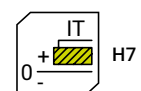
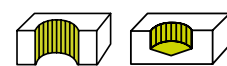

Артикул	Обозначение по ГОСТ	D, мм	KM	I, мм	L, мм	Z, шт
1257508	2363-2051	10,0	KM1	16,0	140,0	4
1257512	2363-2052	11,0	KM1	16,0	140,0	4
1258996	2363-2053	12,0	KM1	16,0	150,0	4
1257520	2363-2054	13,0	KM1	16,0	150,0	4
1257524	2363-2055	14,0	KM1	16,0	160,0	4
1257528	2363-2056	15,0	KM1	16,0	160,0	4
1257532	2363-2057	16,0	KM2	19,0	170,0	6
1257536	2363-2058	17,0	KM2	19,0	170,0	6
1257540	2363-2059	18,0	KM2	19,0	180,0	6
1257544	2363-2060	19,0	KM2	19,0	190,0	6
1257548	2363-2061	20,0	KM2	19,0	190,0	6
1257552	2363-2062	21,0	KM2	19,0	190,0	6
1257556	2363-2063	22,0	KM2	19,0	200,0	6
1257560	2363-3738	23,0	KM2	19,0	200,0	6
1257564	2363-2065	24,0	KM3	19,0	210,0	6
1257568	2363-2066	25,0	KM3	19,0	220,0	6
1257572	2363-2067	26,0	KM3	22,0	220,0	6
1257576	2363-2068	27,0	KM3	22,0	220,0	6
1257580	2363-2069	28,0	KM3	22,0	240,0	6
1257584	2363-2070	30,0	KM3	22,0	240,0	6
1257588	2363-2071	32,0	KM3	22,0	240,0	6

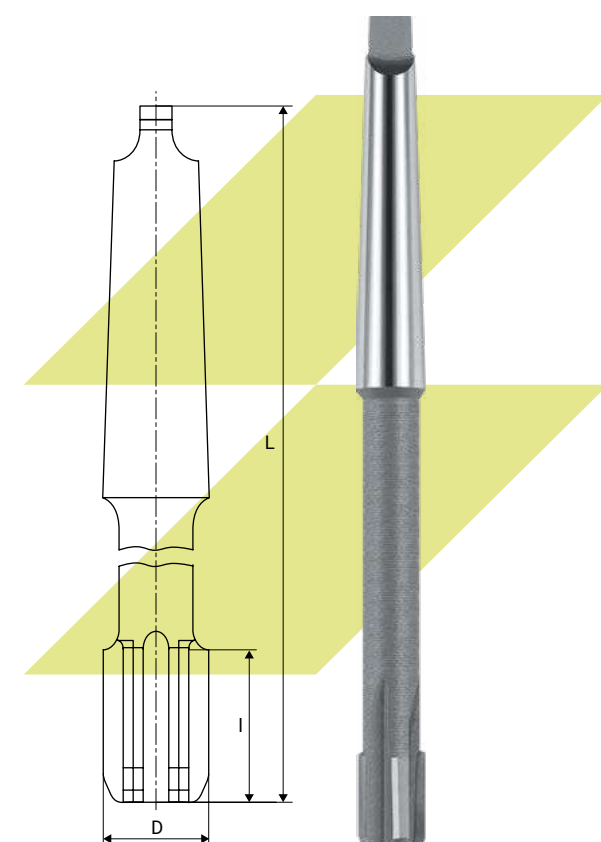

Развёртки машинные, оснащённые твердосплавными напайваемыми пластинами, с коническим хвостовиком

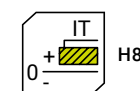
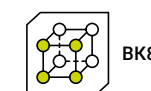
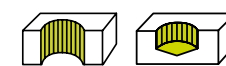

Артикул	Обозначение по ГОСТ	D, мм	KM	I, мм	L, мм	Z, шт
1257509	2363-2051	10,0	KM1	16,0	140,0	4
1257513	2363-2052	11,0	KM1	16,0	140,0	4
1257517	2363-2053	12,0	KM1	16,0	150,0	4
1257521	2363-2054	13,0	KM1	16,0	150,0	4
1257525	2363-2055	14,0	KM1	16,0	160,0	4
1257529	2363-2056	15,0	KM1	16,0	160,0	4
1257533	2363-2057	16,0	KM2	19,0	170,0	6
1257537	2363-2058	17,0	KM2	19,0	170,0	6
1257541	2363-2059	18,0	KM2	19,0	180,0	6
1257545	2363-2060	19,0	KM2	19,0	190,0	6
1257549	2363-2061	20,0	KM2	19,0	190,0	6
1257553	2363-2062	21,0	KM2	19,0	190,0	6
1257557	2363-2063	22,0	KM2	19,0	200,0	6
1257561	2363-3738	23,0	KM2	19,0	200,0	6
1257565	2363-2065	24,0	KM3	19,0	210,0	6
1257569	2363-2066	25,0	KM3	19,0	220,0	6
1257573	2363-2067	26,0	KM3	22,0	220,0	6
1257577	2363-2068	27,0	KM3	22,0	220,0	6
1257581	2363-2069	28,0	KM3	22,0	240,0	6
1257585	2363-2070	30,0	KM3	22,0	240,0	6
1257589	2363-2071	32,0	KM3	22,0	240,0	6

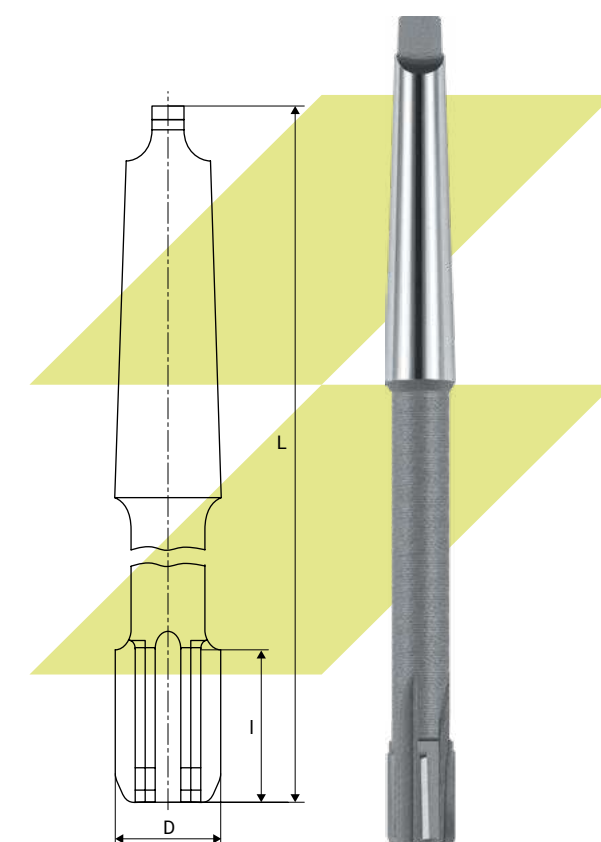

Развёртки машинные, оснащённые твердосплавными напайваемыми пластинами, с коническим хвостовиком

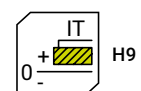

Артикул	Обозначение по ГОСТ	D, мм	KM	I, мм	L, мм	Z, шт
1257510	2363-2051	10,0	KM1	16,0	140,0	4
1257514	2363-2052	11,0	KM1	16,0	140,0	4
1258997	2363-2053	12,0	KM1	16,0	150,0	4
1257522	2363-2054	13,0	KM1	16,0	150,0	4
1257526	2363-2055	14,0	KM1	16,0	160,0	4
1257530	2363-2056	15,0	KM1	16,0	160,0	4
1257534	2363-2057	16,0	KM2	19,0	170,0	6
1257538	2363-2058	17,0	KM2	19,0	170,0	6
1257542	2363-2059	18,0	KM2	19,0	180,0	6
1257546	2363-2060	19,0	KM2	19,0	190,0	6
1257550	2363-2061	20,0	KM2	19,0	190,0	6
1257554	2363-2062	21,0	KM2	19,0	190,0	6
1257558	2363-2063	22,0	KM2	19,0	200,0	6
1257562	2363-3738	23,0	KM2	19,0	200,0	6
1257566	2363-2065	24,0	KM3	19,0	210,0	6
1257570	2363-2066	25,0	KM3	19,0	220,0	6
1257574	2363-2067	26,0	KM3	22,0	220,0	6
1257578	2363-2068	27,0	KM3	22,0	220,0	6
1257582	2363-2069	28,0	KM3	22,0	240,0	6
1257586	2363-2070	30,0	KM3	22,0	240,0	6
1257590	2363-2071	32,0	KM3	22,0	240,0	6

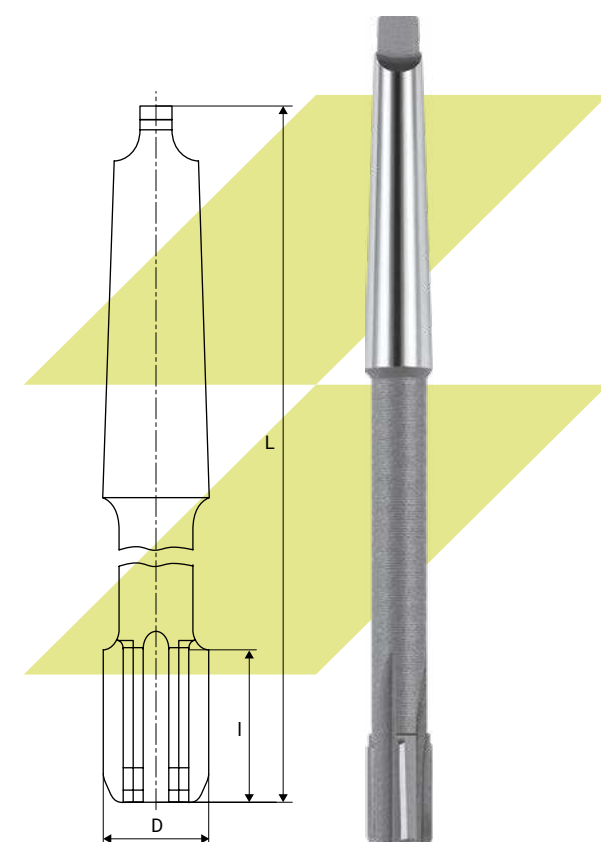

Развёртки машинные, оснащённые твердосплавными напайваемыми пластинами, с коническим хвостовиком

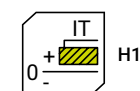
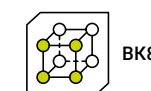

Артикул	Обозначение по ГОСТ	D, мм	KM	I, мм	L, мм	Z, шт
1257511	2363-2051	10,0	KM1	16,0	140,0	4
1257515	2363-2052	11,0	KM1	16,0	140,0	4
1257519	2363-2053	12,0	KM1	16,0	150,0	4
1257523	2363-2054	13,0	KM1	16,0	150,0	4
1257527	2363-2055	14,0	KM1	16,0	160,0	4
1257531	2363-2056	15,0	KM1	16,0	160,0	4
1257535	2363-2057	16,0	KM2	19,0	170,0	6
1257539	2363-2058	17,0	KM2	19,0	170,0	6
1257543	2363-2059	18,0	KM2	19,0	180,0	6
1257547	2363-2060	19,0	KM2	19,0	190,0	6
1257551	2363-2061	20,0	KM2	19,0	190,0	6
1257555	2363-2062	21,0	KM2	19,0	190,0	6
1257559	2363-2063	22,0	KM2	19,0	200,0	6
1257563	2363-3738	23,0	KM2	19,0	200,0	6
1257567	2363-2065	24,0	KM3	19,0	210,0	6
1257571	2363-2066	25,0	KM3	19,0	220,0	6
1257575	2363-2067	26,0	KM3	22,0	220,0	6
1257579	2363-2068	27,0	KM3	22,0	220,0	6
1257583	2363-2069	28,0	KM3	22,0	240,0	6
1257587	2363-2070	30,0	KM3	22,0	240,0	6
1257591	2363-2071	32,0	KM3	22,0	240,0	6

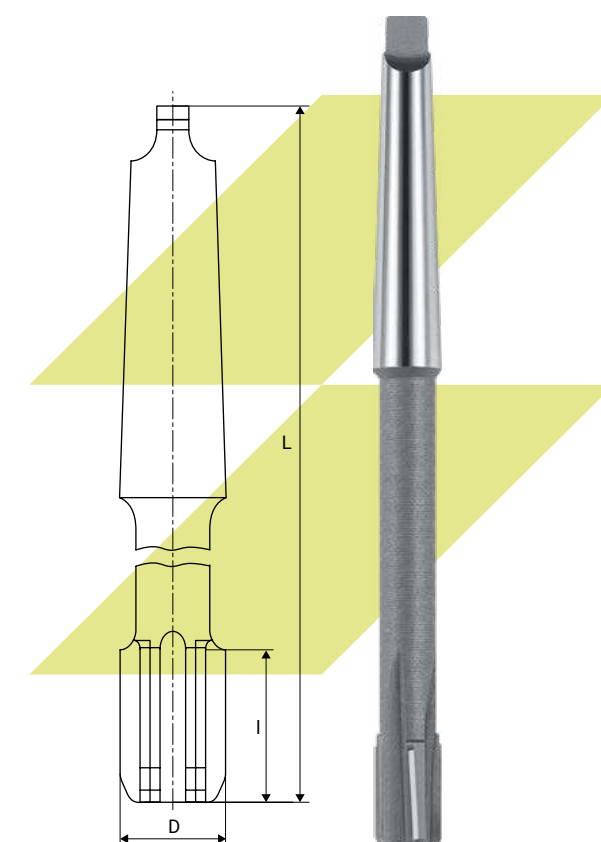

Развёртки машинные цельные из быстрорежущей стали с цилиндрическим хвостовиком

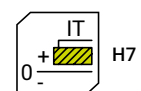
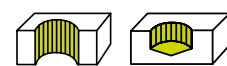

Артикул	Обозначение по ГОСТ	D, мм	d, мм	l, мм	L, мм	Z, шт
1179922	2368-0112	1,4	1,4	8,0	40,0	4
1179925	2368-0116	1,6	1,6	9,0	43,0	4
1179928	2368-0118	1,8	1,8	10,0	46,0	4
1179931	2363-3382	2,0	2,0	11,0	49,0	6
1179934	2363-3384	2,2	2,2	12,0	53,0	6
1179937	2363-3386	2,5	2,5	14,0	57,0	6
1179940	2363-3388	2,8	2,8	15,0	61,0	6
1584314	2363-0043	3,0	3,0	15,0	61,0	6
1261536	2363-0031	3,2	3,2	16,0	65,0	6
1265326	2363-0717	4,0	4,0	32,0	90,0	6
1597147	2363-0059	5,0	5,0	23,0	86,0	6
105171	2363-0081	5,5	5,6	26,0	93,0	6
1256816	2363-0071	8,0	8,0	33,0	117,0	6
1179945	—	8,5	8,0	33,0	117,0	6
1376496	2363-3391	10,0	10,0	38,0	133,0	6
1337377	2368-0121	17,0	14,0	54,0	175,0	8
1337380	2368-0123	18,0	14,0	56,0	182,0	8

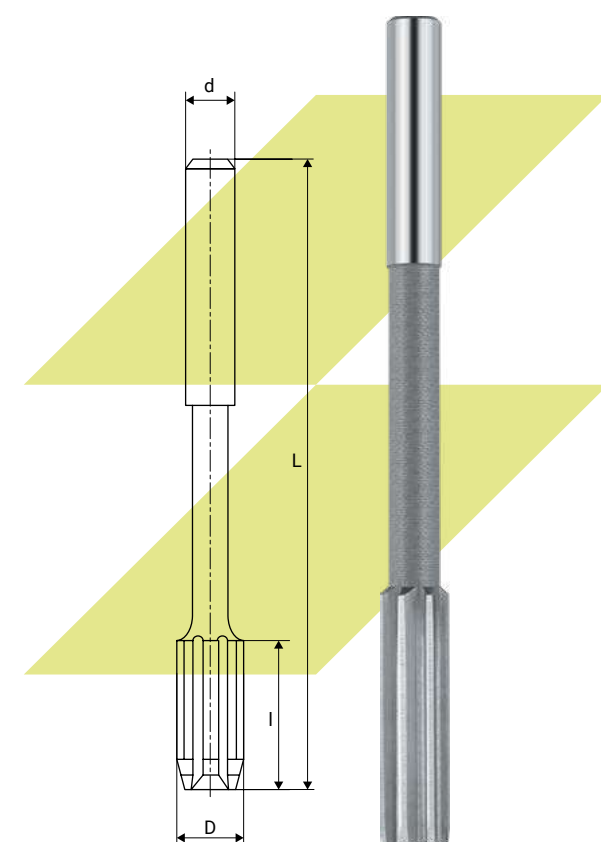

Развёртки машинные цельные из быстрорежущей стали с цилиндрическим хвостовиком

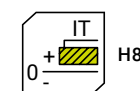
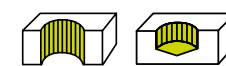

Артикул	Обозначение по ГОСТ	D, мм	d, мм	l, мм	L, мм	Z, шт
1179923	2368-0112	1,4	2,0	8,0	40,0	4
1179926	2368-0116	1,6	1,6	9,0	43,0	4
1179929	2368-0118	1,8	1,8	10,0	46,0	4
1179932	2363-3382	2,0	2,0	11,0	49,0	6
1179935	2363-3384	2,2	2,2	12,0	53,0	6
1179938	2363-3386	2,5	2,5	14,0	57,0	6
1179941	2363-3388	2,8	2,8	15,0	61,0	6
1584315	2363-0043	3,0	3,0	15,0	61,0	6
1261537	2363-0031	3,2	3,2	16,0	65,0	6
1105633	2363-0047	3,5	3,5	18,0	70,0	6
1265328	2363-0718	4,2	4,2	32,0	90,0	6
1261513	2363-0059	5,0	5,0	23,0	86,0	6
1265329	2363-0510	5,0	5,0	40,0	100,0	6
105172	2363-0081	5,5	5,6	26,0	93,0	6
1227785	2363-0063	6,0	5,6	26,0	93,0	6
105189	2363-0067	7,0	7,1	31,0	109,0	6
1179943	2363-0071	8,0	8,0	33,0	117,0	6
1265332	2363-0518	8,0	8,0	60,0	125,0	6
1179946	—	8,5	8,0	33,0	117,0	6
105211	2363-0093	9,0	9,0	36,0	125,0	6
1265334	2363-0739	10,0	10,0	80,0	140,0	6
1337375	2363-3404	16,0	12,5	52,0	170,0	8
1337378	2368-0121	17,0	14,0	54,0	175,0	8
1337381	2368-0123	18,0	14,0	56,0	182,0	8
1337384	2368-0125	19,0	16,0	58,0	189,0	8
1337387	2368-0127	20,0	16,0	60,0	195,0	8

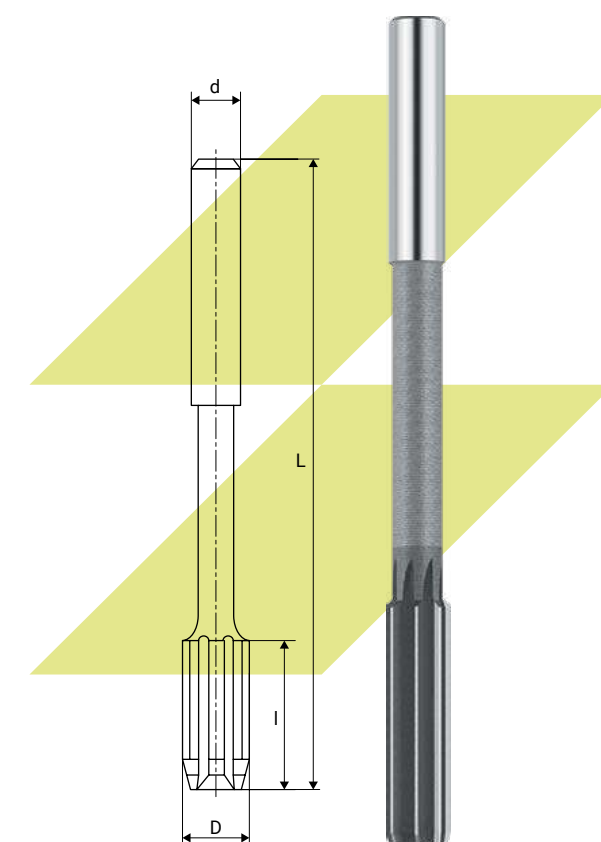

Развёртки машинные цельные из быстрорежущей стали с цилиндрическим хвостовиком

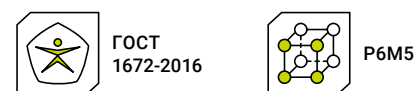
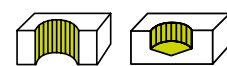

Артикул	Обозначение по ГОСТ	D, мм	d, мм	l, мм	L, мм	Z, шт
1179924	2368-0112	1,4	2,0	8,0	40,0	4
1179927	2368-0116	1,6	1,6	9,0	43,0	4
1179930	2368-0118	1,8	1,8	10,0	46,0	4
1179933	2363-3382	2,0	2,0	11,0	49,0	6
1179936	2363-3384	2,2	2,2	12,0	53,0	6
1179939	2363-3386	2,5	2,5	14,0	57,0	6
1179942	2363-3388	2,8	2,8	15,0	61,0	6
119218	2363-0043	3,0	3,0	15,0	61,0	6
1261538	2363-0031	3,2	3,2	16,0	65,0	6
105145	2363-0047	3,5	3,5	18,0	70,0	6
1261509	2363-0055	4,5	4,5	21,0	80,0	6
1109594	2363-0081	5,5	5,6	26,0	93,0	6
1220077	2363-0063	6,0	5,6	26,0	93,0	6
1179944	2363-0071	8,0	8,0	33,0	117,0	6
1179947	—	8,5	8,0	33,0	117,0	6
105213	2363-0093	9,0	9,0	36,0	125,0	6
1265333	2363-0520	9,0	9,0	70,0	130,0	6
1337374	2363-3402	15,0	12,5	50,0	162,0	8
1337376	2363-3404	16,0	12,5	52,0	170,0	8
1337379	2368-0121	17,0	14,0	54,0	175,0	8
1337382	2368-0123	18,0	14,0	56,0	182,0	8
1337388	2368-0127	20,0	16,0	60,0	195,0	8

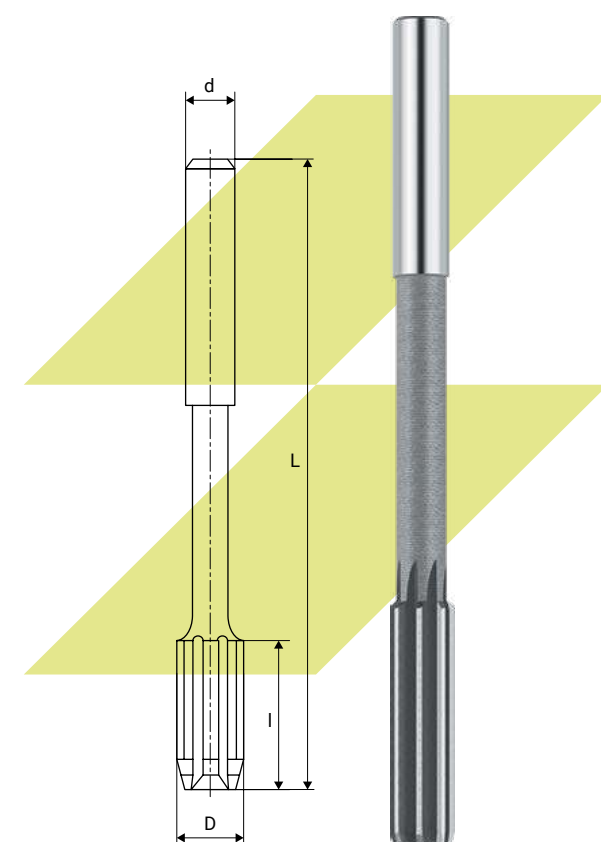

Развёртки машинные цельные из быстрорежущей стали с коническим хвостовиком

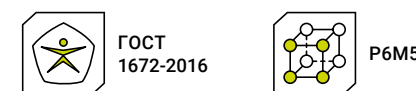
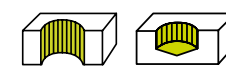

Артикул	Обозначение по ГОСТ	D, мм	KM	l, мм	L, мм	Z, шт
1252584	2363-3409	6,0	KM1	26,0	138,0	6
1252585	2363-3413	7,0	KM1	31,0	150,0	6
1252586	2363-3416	8,0	KM1	33,0	156,0	6
1252587	2363-3419	9,0	KM1	36,0	162,0	6
1179948	2363-0189	10,0	KM1	16,0	140,0	6
1289726	2363-3423	10,0	KM1	38,0	168,0	6
1179951	—	10,5	KM1	16,0	140,0	8
105240	2363-0107	11,0	KM1	16,0	140,0	8
1179954	2363-0111	12,0	KM1	18,0	150,0	8
105265	2363-0115	13,0	KM1	18,0	150,0	8
116124	—	13,0	KM1	30,0	150,0	8
1179957	2363-0119	14,0	KM1	18,0	160,0	8
1330801	2363-3436	14,0	KM1	47,0	189,0	8
117564	2363-0123	15,0	KM1	18,0	160,0	8
1261539	2363-0127	16,0	KM2	18,0	170,0	8
1330794	2363-3449	16,0	KM2	52,0	210,0	8
105308	2363-0131	17,0	KM2	18,0	170,0	8
105341	2363-0376	19,0	KM2	20,0	190,0	8
1261541	2363-0379	20,0	KM2	20,0	190,0	8
1330796	2363-3463	20,0	KM2	60,0	228,0	8
1261542	2368-0139	21,0	KM2	20,0	200,0	8
1330797	2368-0129	21,0	KM2	62,0	232,0	8
1261389	2363-0385	22,0	KM2	20,0	200,0	8
1330799	2363-3466	22,0	KM2	64,0	237,0	8
105379	2363-0388	24,0	KM3	20,0	210,0	8
1256818	2363-0391	25,0	KM3	22,0	220,0	8
1330802	2363-3473	25,0	KM3	68,0	268,0	8
105399	2363-0394	26,0	KM3	22,0	220,0	8
1479880	2363-0656	32,0	KM3	25,0	240,0	10
1479883	2363-3503	36,0	KM4	79,0	325,0	12
1479886	2363-3509	40,0	KM4	81,0	329,0	12
1479889	2363-3519	45,0	KM4	83,0	336,0	12
1479892	2363-3529	50,0	KM4	86,0	344,0	12

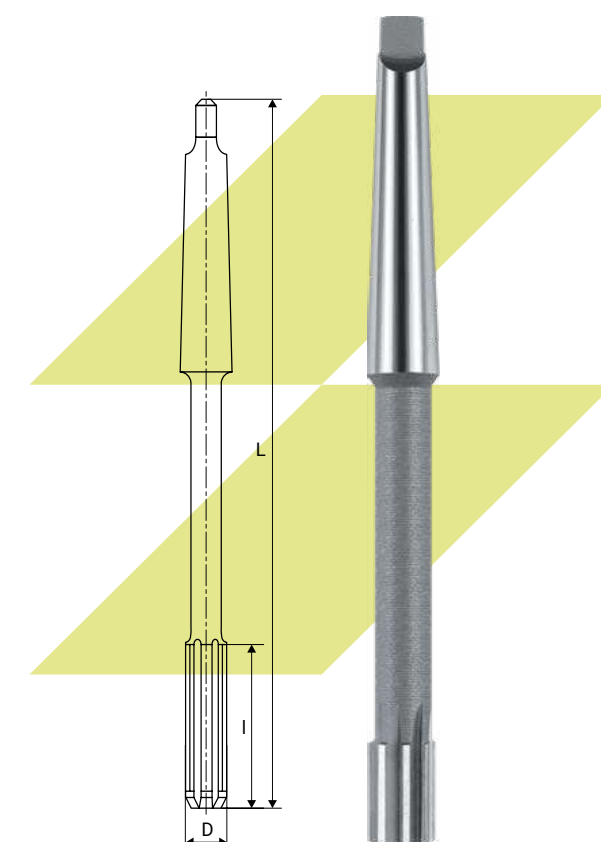

Развёртки машинные цельные из быстрорежущей стали с коническим хвостовиком

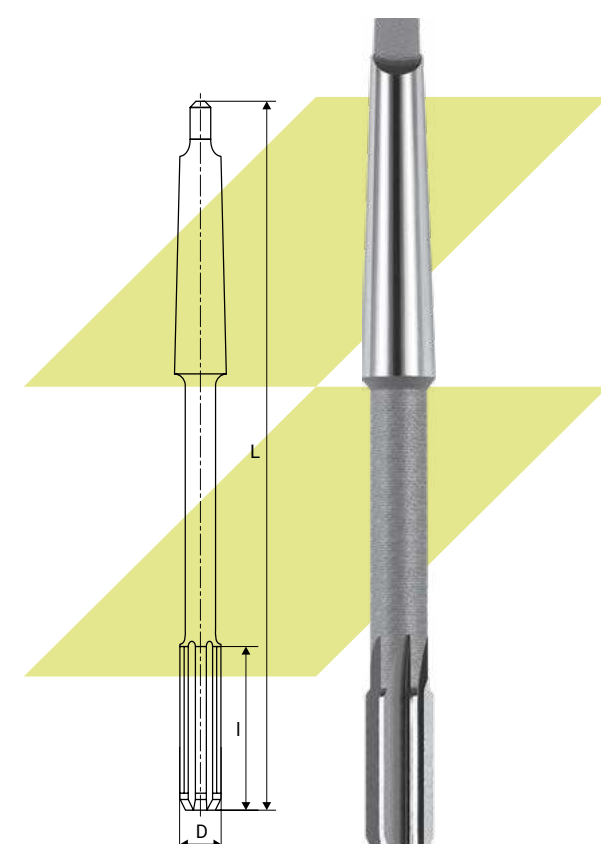
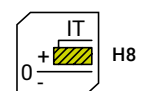
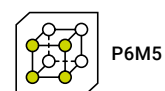
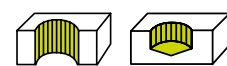

Артикул	Обозначение по ГОСТ	D, мм	KM	I, мм	L, мм	Z, шт
1331198	2363-3419	9,0	KM1	36,0	162,0	6
1179949	2363-3423	10,0	KM1	16,0	140,0	6
1289727	2363-0189	10,0	KM1	38,0	168,0	6
1179952	—	10,5	KM1	16,0	140,0	8
105241	2363-0107	11,0	KM1	16,0	140,0	8
1179955	2363-0111	12,0	KM1	18,0	150,0	8
1330793	2363-3429	12,0	KM1	44,0	182,0	8
105266	2363-0115	13,0	KM1	18,0	150,0	8
1256817	2363-0119	14,0	KM1	18,0	160,0	8
1331037	2363-3436	14,0	KM1	47,0	189,0	8
116080	2363-0123	15,0	KM1	18,0	160,0	8
105299	2363-0127	16,0	KM2	18,0	170,0	8
105309	2363-0131	17,0	KM2	18,0	170,0	8
105328	2363-0373	18,0	KM2	20,0	180,0	8
105343	2363-0376	19,0	KM2	20,0	190,0	8
105353	2363-0379	20,0	KM2	20,0	190,0	8
1261390	2363-0385	22,0	KM2	20,0	200,0	8
1330800	2363-3466	22,0	KM2	64,0	237,0	8
1331193	2368-0143	23,0	KM2	20,0	210,0	8
105380	2363-0388	24,0	KM3	20,0	210,0	8
1256819	2363-0391	25,0	KM3	22,0	220,0	8
1330803	2363-3472	25,0	KM3	68,0	268,0	8
1479881	2363-0656	32,0	KM3	25,0	240,0	10
1479884	2363-3503	36,0	KM4	79,0	325,0	12
1479887	2363-3509	40,0	KM4	81,0	329,0	12
1479890	2363-3519	45,0	KM4	83,0	336,0	12
1479893	2363-3529	50,0	KM4	86,0	344,0	12

Развёртки машинные цельные из быстрорежущей стали с коническим хвостовиком

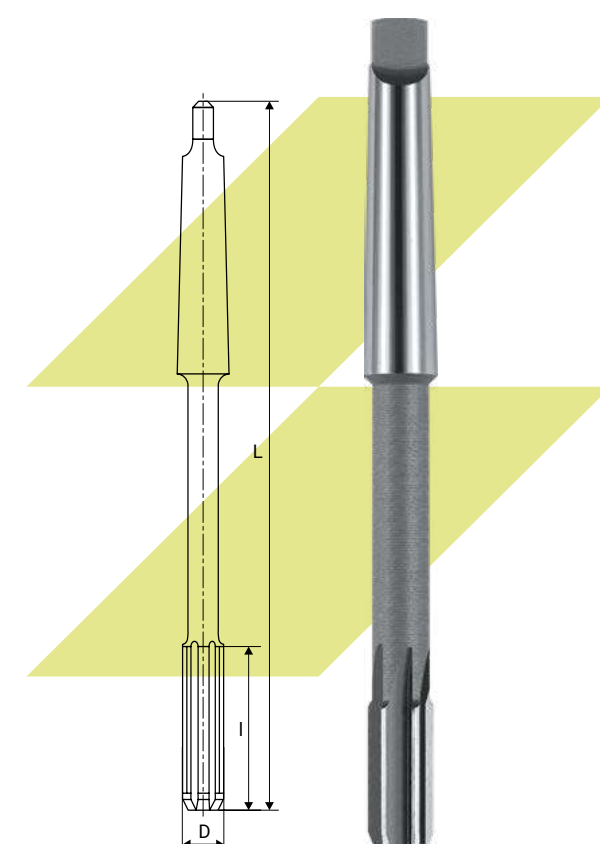
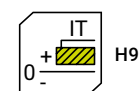
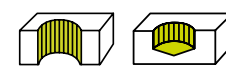

Артикул	Обозначение по ГОСТ	D, мм	KM	I, мм	L, мм	Z, шт
1331196	2363-3416	8,0	KM1	33,0	156,0	6
1179950	2363-0189	10,0	KM1	16,0	140,0	6
1289728	2363-3423	10,0	KM1	38,0	168,0	6
1179953	—	10,5	KM1	16,0	140,0	8
105244	2363-0107	11,0	KM1	16,0	140,0	8
1179956	2363-0111	12,0	KM1	18,0	150,0	8
1289628	2363-3429	12,0	KM1	44,0	182,0	8
105267	2363-0115	13,0	KM1	18,0	150,0	8
105278	2363-0119	14,0	KM1	18,0	160,0	8
105288	2363-0123	15,0	KM1	18,0	160,0	8
1261540	2363-0127	16,0	KM2	18,0	170,0	8
1330795	2363-3449	16,0	KM2	52,0	210,0	8
105311	2363-0131	17,0	KM2	18,0	170,0	8
105329	2363-0373	18,0	KM2	20,0	180,0	8
105344	2363-0376	19,0	KM2	20,0	190,0	8
1261543	2368-0139	21,0	KM2	20,0	200,0	8
1330798	2368-0129	21,0	KM2	62,0	232,0	8
105366	2363-0385	22,0	KM2	20,0	200,0	8
1128521	2368-0143	23,0	KM2	20,0	210,0	8
105384	2363-0388	24,0	KM3	20,0	210,0	8
1584317	2363-0391	25,0	KM3	22,0	220,0	8
105418	2363-0650	28,0	KM3	22,0	240,0	8
1479882	2363-0656	32,0	KM3	25,0	240,0	10
1479885	2363-3503	36,0	KM4	79,0	325,0	12
1479888	2363-3509	40,0	KM4	81,0	329,0	12
1479891	2363-3519	45,0	KM4	83,0	336,0	12
1479894	2363-3529	50,0	KM4	86,0	344,0	12

Развёртки машинные цельные из быстрорежущей стали с коническим хвостовиком

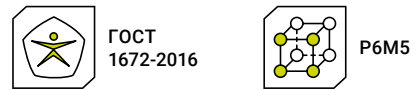
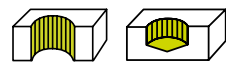

Артикул	Обозначение по ГОСТ	D, мм	KM	I, мм	L, мм	Z, шт
1185060	2363-0189	10,0	KM1	16,0	140,0	6
1289729	2363-3423	10,0	KM1	38,0	168,0	6
1185061	2363-0111	12,0	KM1	18,0	150,0	8
1289629	2363-3429	12,0	KM1	44,0	182,0	8
1185062	2363-0119	14,0	KM1	18,0	160,0	8
1185063	2363-0127	16,0	KM2	18,0	170,0	8
1185064	2363-0373	18,0	KM2	20,0	180,0	8
1185065	2363-0379	20,0	KM2	20,0	190,0	8
1185066	2363-0385	22,0	KM2	20,0	200,0	8

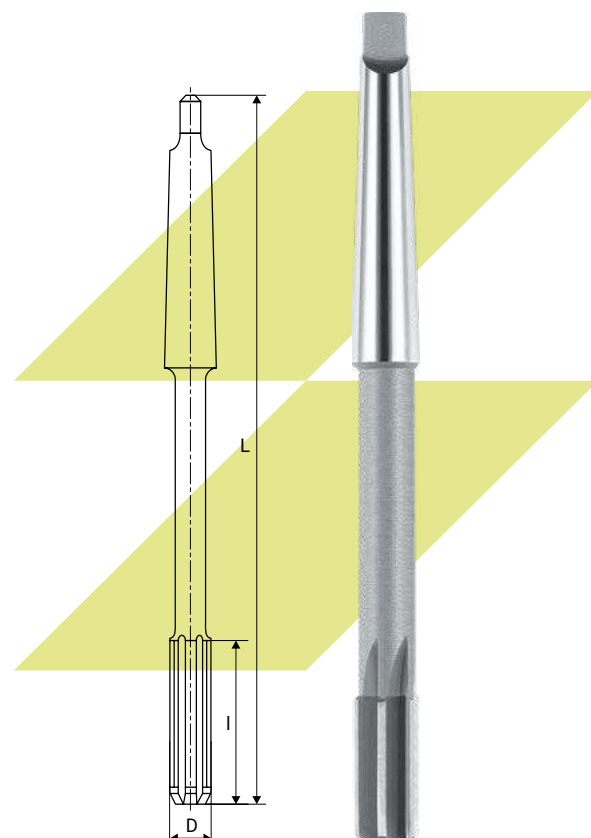

Развёртки машинные цельные из быстрорежущей стали с коническим хвостовиком

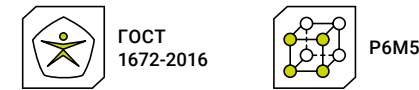
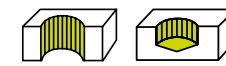

Артикул	Обозначение по ГОСТ	D, мм	KM	I, мм	L, мм	Z, шт
1253487	2363-0189	10,0	KM1	16,0	140,0	6
1220078	2363-0111	12,0	KM1	18,0	150,0	8
1289630	2363-3429	12,0	KM1	44,0	182,0	8
105264	2363-0115	13,0	KM1	18,0	150,0	8
1135462	2363-0119	14,0	KM1	18,0	160,0	8
1108841	2363-0385	22,0	KM2	20,0	200,0	8
1108842	2363-0388	24,0	KM3	20,0	210,0	8

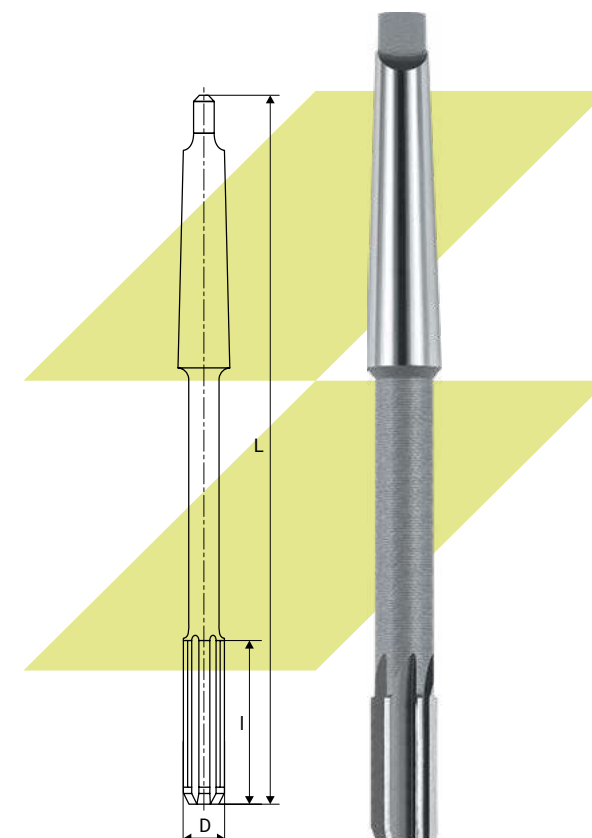

Развёртки котельные из быстрорежущей стали

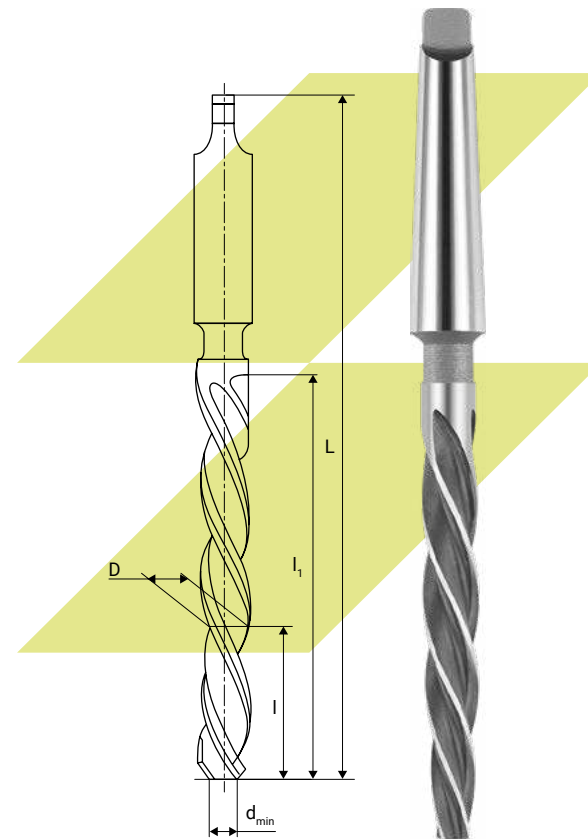
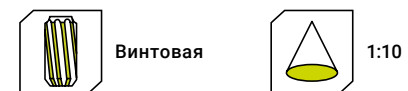
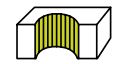

Артикул	Обозначение по ГОСТ	D, мм	D _{min'} , мм	KM	L ₁ , мм	L ₂ , мм	L ₃ , мм
1335825	2363-0961	6,4	3,4	KM1	30,0	75,0	155,0
1335826	2363-0962	7,4	4,2	KM1	32,0	80,0	160,0
1479813	—	10,5	7,4	KM1	38,0	100,0	180,0
1252589	2363-0964	11,0	7,0	KM1	40,0	100,0	180,0
1252590	2363-0966	15,0	10,0	KM2	50,0	125,0	220,0
115019	2363-0967	17,0	11,6	KM2	54,0	135,0	230,0
105128	2363-0968	19,0	13,2	KM3	58,0	140,0	260,0
117353	—	20,0	13,0	KM3	62,0	165,0	280,0
105130	2363-0969	21,0	14,8	KM3	62,0	150,0	270,0
117355	2363-0970	23,0	16,4	KM3	66,0	160,0	280,0
1252591	2363-0971	25,0	17,8	KM3	72,0	175,0	295,0
1377437	—	26,0	18,8	KM3	72,0	180,0	296,0
1377438	—	27,0	19,2	KM3	78,0	195,0	311,0

Артикул	Обозначение по ГОСТ	D, мм	D _{min'} , мм	KM	L ₁ , мм	L ₂ , мм	L ₃ , мм
1252592	2363-0972	28,0	20,2	KM3	78,0	190,0	310,0
1252593	2363-0974	34,0	25,2	KM4	88,0	220,0	365,0
105136	2363-0975	37,0	28,2	KM4	88,0	220,0	365,0
1252594	2363-0976	40,0	30,8	KM4	92,0	230,0	375,0

Развёртки машинные конические конусностью 1:16 с коническим хвостовиком, дюймовые

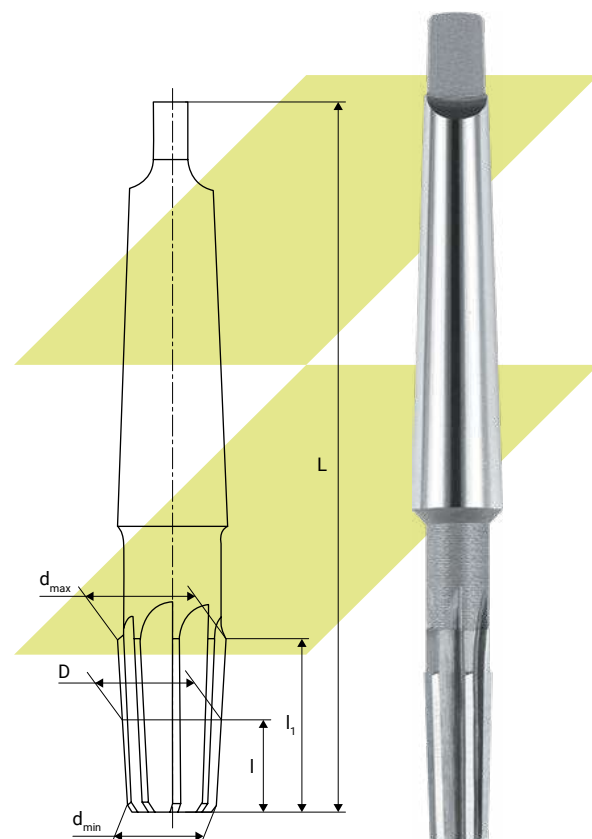
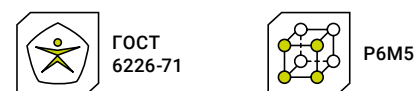
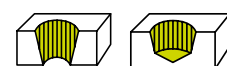

Артикул	Обозначение по ГОСТ	D дюйм	D ₁ мм	D _{min} ' мм	D _{max} ' мм	KM	I ₁ мм	I ₁ мм	L ₁ мм	Z, шт
1378532	2373-0032	K 1/8"	8,766	8,141	9,454	KM1	11,0	22,0	110,0	6
1441282	2373-0033	K 1/4"	12,127	10,439	12,127	KM1	15,0	28,0	115,0	8
1751947	2373-0036	K 3/4"	24,119	22,713	24,994	KM3	38,0	24,0	160,0	6
105079	2373-0034	K 3/8"	14,797	13,859	15,672	KM2	16,0	30,0	130,0	8
118652	2373-0037	K1"	29,694	28,194	30,882	KM3	26,0	45,0	170,0	6
1441301	2373-0038	K1 1/4"	38,451	36,888	39,764	KM4	27,0	48,0	200,0	6
105076	2373-0039	K1 1/2"	44,520	42,957	45,958	KM4	27,0	50,0	200,0	6
1103207	2373-0040	K2"	56,558	54,933	58,058	KM5	28,0	52,0	230,0	6

Развёртки машинные конические конусностью 1:16 с коническим хвостовиком, трубные

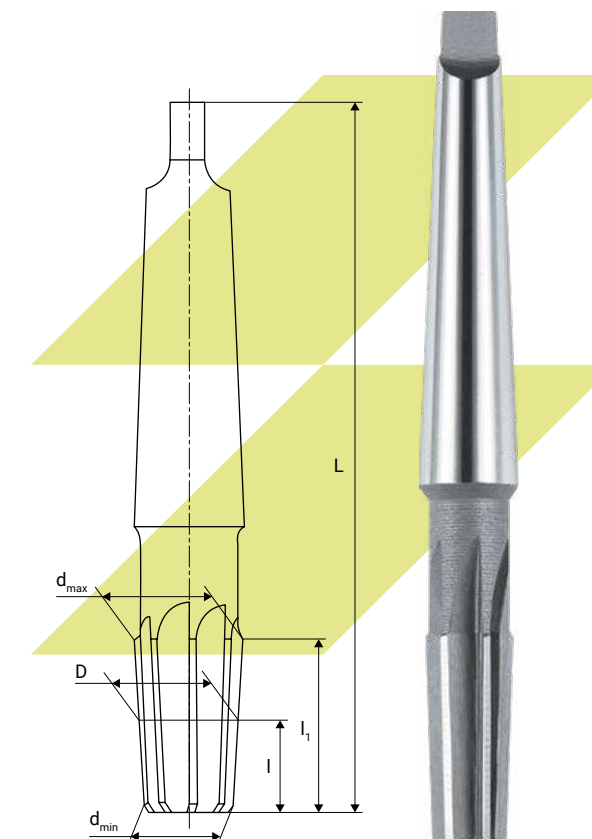
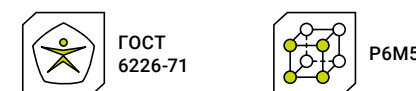

Артикул	Обозначение по ГОСТ	D дюйм	D ₁ мм	D _{min} ' мм	D _{max} ' мм	KM	I ₁ мм	I ₁ мм	L ₁ мм	Z, шт
1378533	2373-0051	Rc 1/8"	8,567	7,879	9,192	KM1	12,0	22,0	110,0	6
1378531	2373-0052	Rc 1/4"	11,446	10,508	12,196	KM1	16,0	28,0	115,0	8
1378534	2373-0054	Rc 1/2"	18,632	17,351	19,445	KM2	22,0	35,0	135,0	8

Развёртки машинные конические конусностью 1:30 с коническим хвостовиком

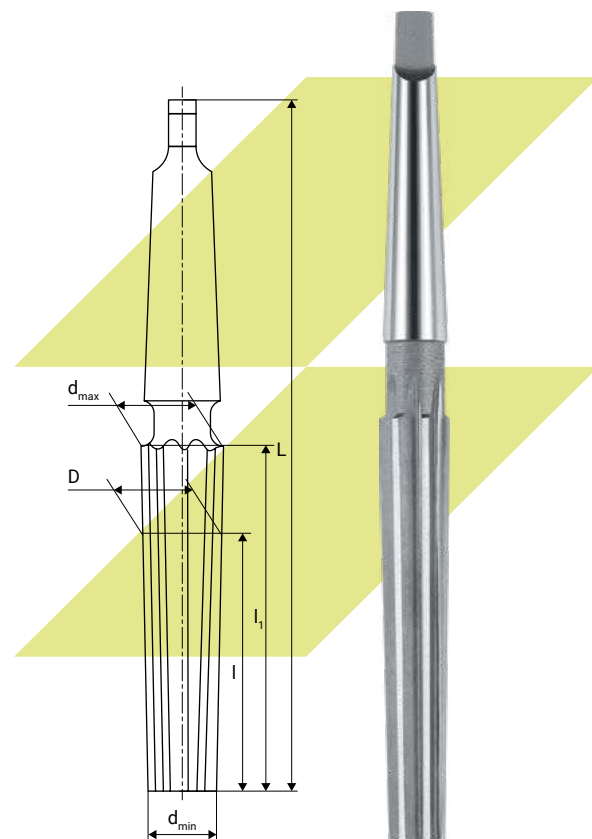
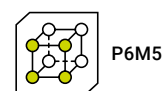
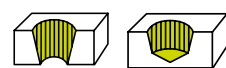

Артикул	Обозначение по ГОСТ	D, мм	D _{min'} , мм	D _{max'} , мм	KM	I, мм	I ₁ , мм	L, мм	Z, шт	Квалитет
1265403	2373-0081-1	13,0	10,9	13,6	KM1	62,0	80,0	160,0	5	предварительная
1265402	2373-0081	13,0	10,9	13,6	KM1	62,0	80,0	160,0	7	чистовая
1265405	2373-0082-1	16,0	13,6	16,6	KM2	72,0	90,0	185,0	5	предварительная
1265404	2373-0082	16,0	13,6	16,6	KM2	72,0	90,0	185,0	7	чистовая
1265407	2373-0083-1	19,0	16,2	19,6	KM3	84,0	102,0	220,0	5	предварительная
1265406	2373-0083	19,0	16,2	19,6	KM3	84,0	102,0	220,0	7	чистовая
1265409	2373-0084-1	22,0	18,9	22,8	KM3	93,0	117,0	235,0	7	предварительная
1265408	2373-0084	22,0	18,9	22,8	KM3	93,0	117,0	235,0	9	чистовая
1265411	2373-0085-1	27,0	23,5	27,8	KM3	105,0	129,0	245,0	7	предварительная
1265410	2373-0085	27,0	23,5	27,0	KM3	105,0	129,0	245,0	9	чистовая
1265413	2373-0086-1	32,0	28,2	32,8	KM4	114,0	138,0	280,0	7	предварительная
1265412	2373-0086	32,0	28,2	32,8	KM4	114,0	138,0	280,0	9	чистовая
1265415	2373-0087-1	40,0	35,8	41,0	KM4	126,0	156,0	300,0	9	предварительная

Артикул	Обозначение по ГОСТ	D, мм	D _{min'} , мм	D _{max'} , мм	KM	I, мм	I ₁ , мм	L, мм	Z, шт	Квалитет
1265414	2373-0087	40,0	35,8	41,0	KM4	126,0	156,0	300,0	11	чистовая
1265417	2373-0088-1	50,0	45,4	51,0	KM5	138,0	168,0	345,0	9	предварительная
1265416	2373-0088	50,0	45,4	51,0	KM5	138,0	168,0	345,0	11	чистовая
1265419	2373-0089-1	60,0	54,9	61,0	KM5	154,0	184,0	360,0	11	предварительная
1265418	2373-0089	60,0	54,9	61,0	KM5	154,0	184,0	360,0	13	чистовая

Развёртки машинные конические конусностью 1:50 с коническим хвостовиком

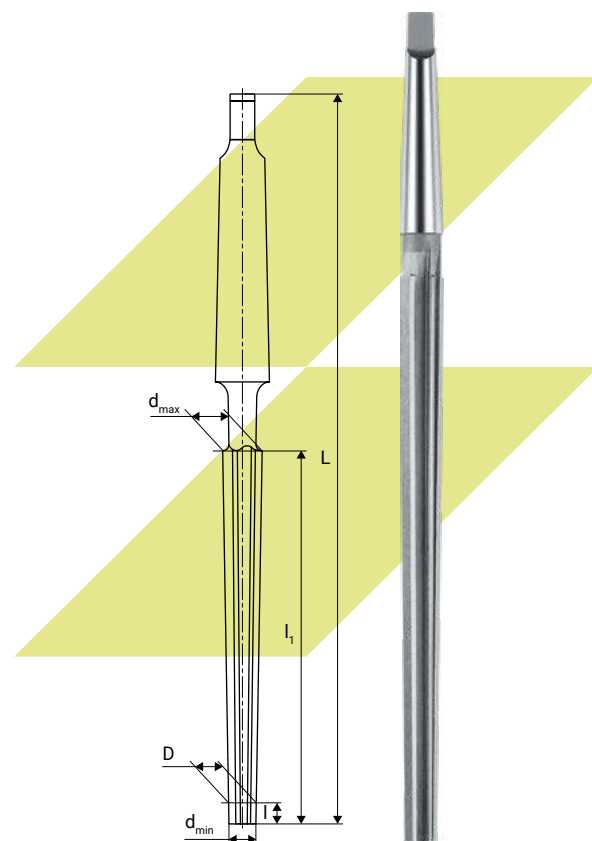
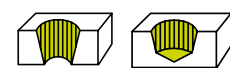

Артикул	Обозначение по ГОСТ	D, мм	D _{min} , мм	D _{max} , мм	KM	I, мм	I ₁ , мм	L, мм	Z, шт
1252595	2373-0211	5,0	4,9	6,36	KM1	5,0	73,0	155,0	5
1252596	2373-0024	6,0	5,9	8,00	KM1	5,0	105,0	187,0	5
1252597	2373-0025	8,0	7,9	10,80	KM1	5,0	145,0	227,0	7
1252598	2373-0027	10,0	9,9	13,40	KM1	5,0	175,0	257,0	7
1252599	2373-0029	12,0	11,8	16,00	KM2	10,0	210,0	315,0	7
1252600	2373-0172	16,0	15,8	20,40	KM2	10,0	230,0	335,0	7
1252601	2373-0174	20,0	19,8	24,80	KM3	10,0	250,0	377,0	7
1252602	2373-0176	25,0	24,7	30,70	KM3	15,0	300,0	427,0	7

Развёртки конические с коническим хвостовиком под Конусы Морзе

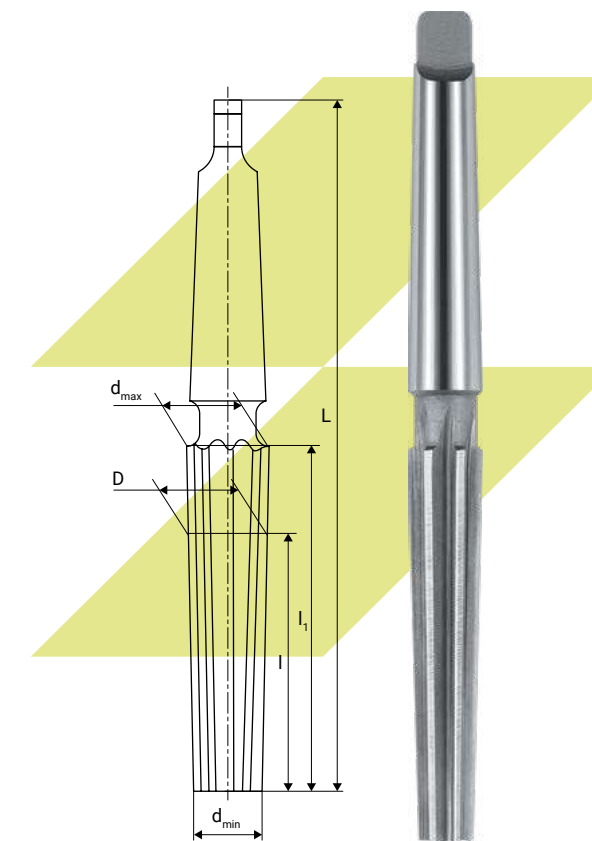
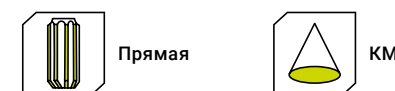
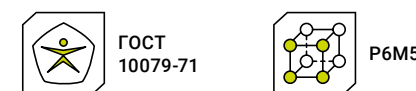
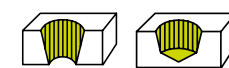

Артикул	Обозначение по ГОСТ	D, мм	D _{min} , мм	D _{max} , мм	Конусы Морзе	KM	I, мм	I ₁ , мм	L, мм	Z, шт	Квалитет
1265421	2373-0131-1	8,795	6,547	9,722	0	KM1	48,0	61,0	137,0	5	предварительная
1265420	2373-0131	9,045	6,547	9,722	0	KM1	48,0	61,0	137,0	6	чистовая
1265423	2373-0132-1	11,815	9,571	12,863	1	KM1	50,0	66,0	142,0	5	предварительная
1265422	2373-0132	12,065	9,571	12,863	1	KM1	50,0	66,0	142,0	7	чистовая
1265425	2373-0133-1	17,530	14,733	18,679	2	KM2	61,0	79,0	173,0	5	предварительная
1265424	2373-0133	17,780	14,733	18,679	2	KM2	61,0	79,0	173,0	7	чистовая
1265427	2373-0134-1	23,575	20,010	24,829	3	KM3	76,0	96,0	212,0	7	предварительная
1265426	2373-0134	23,825	20,010	24,829	3	KM3	76,0	96,0	212,0	9	чистовая
1265429	2373-0135-1	31,017	26,229	32,410	4	KM3	97,0	119,0	240,0	7	предварительная
1265428	2373-0135	31,267	26,229	32,410	4	KM3	97,0	119,0	240,0	9	чистовая
1265431	2373-0201-1	31,017	26,229	32,410	4	KM4	97,0	119,0	263,0	7	предварительная
1265430	2373-0201	31,267	26,229	32,410	4	KM4	97,0	119,0	263,0	9	чистовая
1265433	2373-0136-1	44,149	37,873	45,767	5	KM4	124,0	150,0	295,0	9	предварительная

Артикул	Обозначение по ГОСТ	D, мм	D _{min'} , мм	D _{max'} , мм	Конусы Морзе	KM	I, мм	I ₁ , мм	L, мм	Z, шт	Квалитет
1265432	2373-0136	44,399	37,873	45,767	5	KM4	124,0	150,0	295,0	11	чистовая
1265435	2373-0203-1	44,149	37,873	45,767	5	KM5	124,0	150,0	331,0	9	предварительная
1265434	2373-0203	44,399	37,873	45,767	5	KM5	124,0	150,0	331,0	11	чистовая
1265437	2373-0137-1	63,098	54,171	64,516	6	KM5	176,0	208,0	389,0	11	предварительная
1265436	2373-0137	63,348	54,171	64,516	6	KM5	176,0	208,0	389,0	13	чистовая

Развёртки машинные цельные, насадные

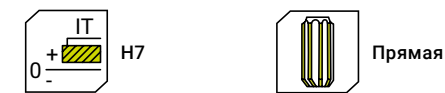
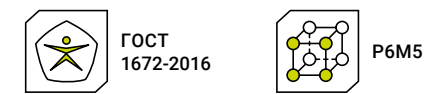
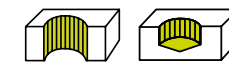

Артикул	Обозначение по ГОСТ	D, мм	d, мм	L, мм	Z, шт
1124179	2363-0245	27,0	13,0	45,0	8
105944	2363-0469	30,0	13,0	30,0	10
115269	2363-0475	34,0	16,0	50,0	10

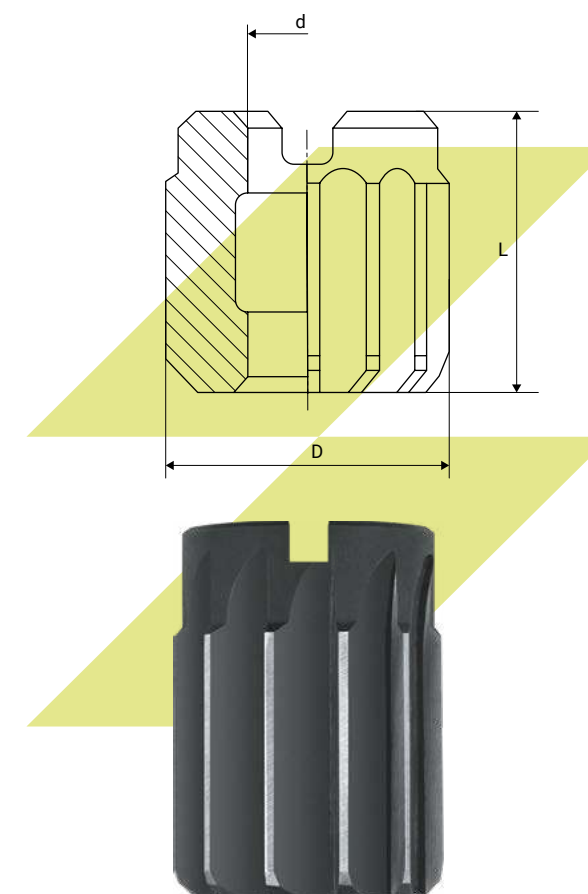

Развёртки машинные цельные, насадные

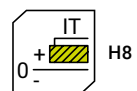
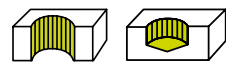

Артикул	Обозначение по ГОСТ	D, мм	d, мм	L, мм	Z, шт
1150824	2363-0248	28,0	13,0	45,0	8
1105336	2363-0469	30,0	13,0	45,0	10
105954	2363-0472	32,0	13,0	30,0	10
105964	2363-0475	34,0	16,0	50,0	10
1105337	2363-0478	35,0	16,0	34,0	10
1131685	—	47,0	22,0	63,0	12

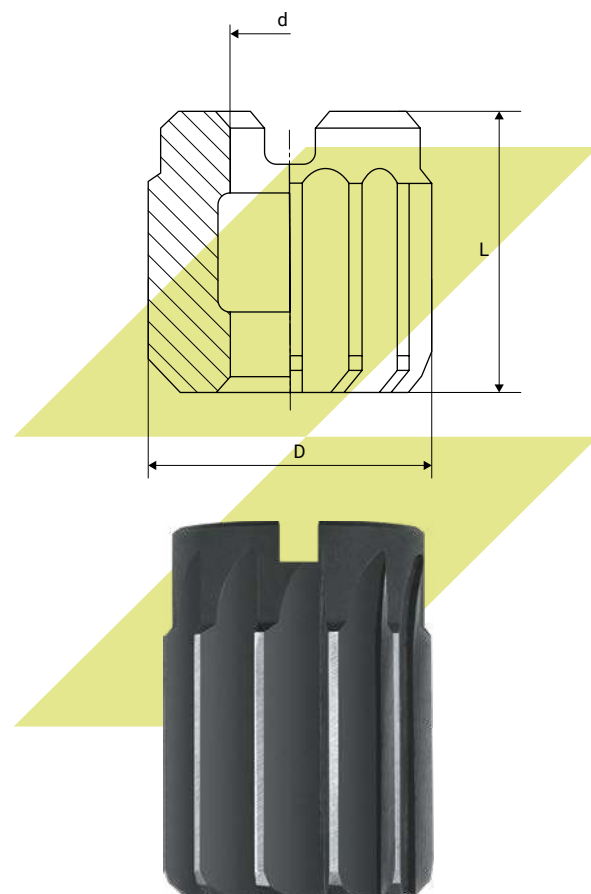

Развёртки машинные цельные, насадные

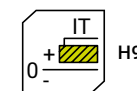
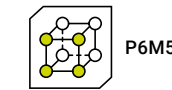
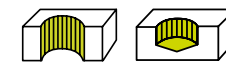

Артикул	Обозначение по ГОСТ	D, мм	d, мм	L, мм	Z, шт
105931	2363-0245	27,0	13,0	45,0	8
105936	2363-0248	28,0	13,0	45,0	8
105945	2363-0469	30,0	13,0	45,0	10
105950	2363-0472	32,0	16,0	50,0	10
105965	2363-0475	34,0	16,0	50,0	10
1105360	—	37,0	19,0	55,0	12
105987	2363-0487	38,0	19,0	56,0	12
106005	—	47,0	22,0	63,0	12
106009	2363-0702	48,0	22,0	63,0	12

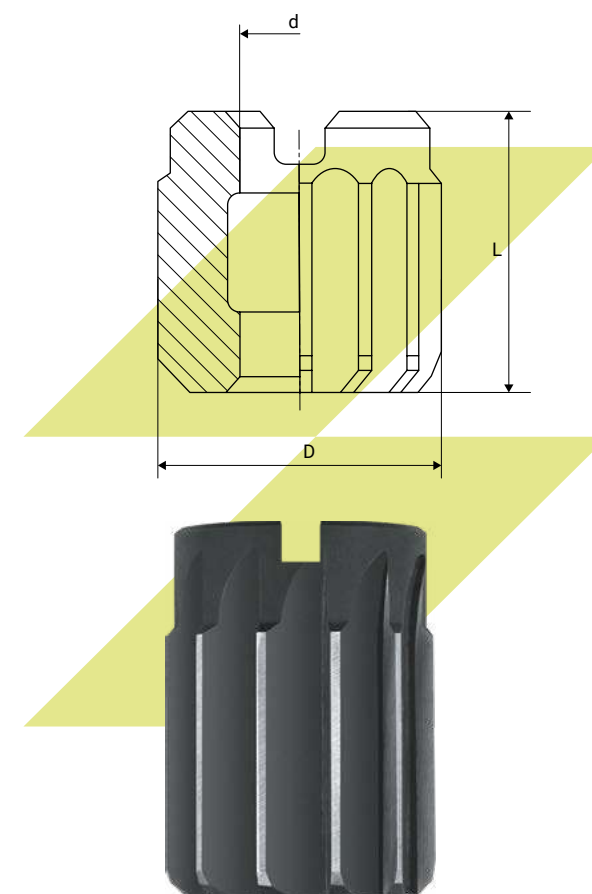

Развёртки машинные насадные со вставными ножами

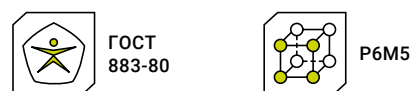
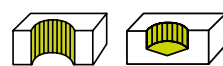

Артикул	Обозначение по ГОСТ	D, мм	d, мм	L, мм	Z, шт
106021	2364-0371	52,0	19,0	72,0	6
106026	2364-0374	55,0	19,0	70,0	6
106029	2364-0377	58,0	22,0	70,0	8
106032	2364-0384	62,0	22,0	70,0	8
106034	2364-0391	65,0	22,0	70,0	8
1128696	2364-0394	68,0	27,0	80,0	8
106041	2364-0397	70,0	27,0	80,0	8
118134	2364-0404	75,0	27,0	80,0	8
1104556	2364-0411	80,0	32,0	80,0	10
106051	2364-0414	85,0	40,0	90,0	10
106052	2364-0417	90,0	40,0	90,0	10
106054	2364-0424	100,0	40,0	90,0	10

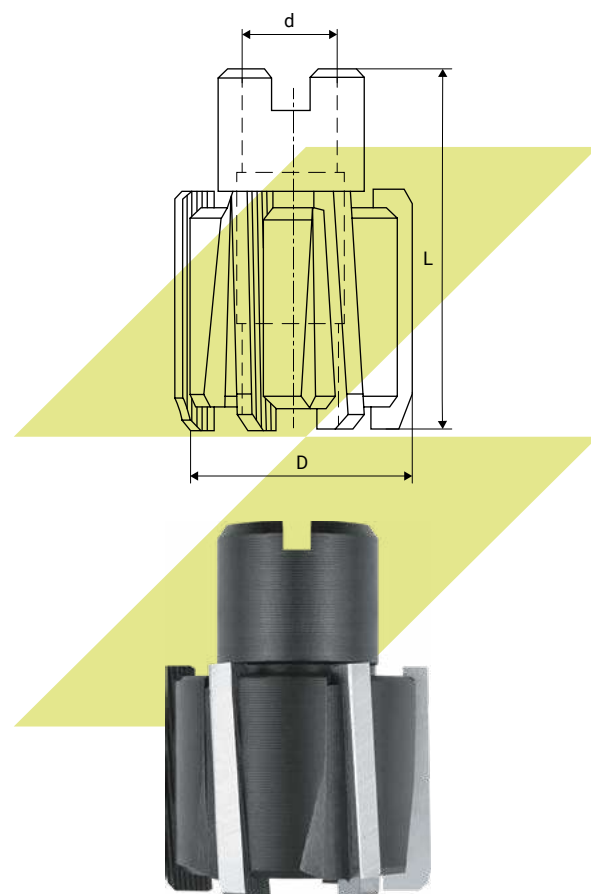

Оправка для насадных развёрток и зенкеров



Артикул	Обозначение по ГОСТ	D, мм	KM	d, мм	I, мм	I ₁ , мм	L, мм
1103035	6230-0331	23,0	KM3	13,0	250,0	30,0	150,0
1108678	6230-0332	23,0	KM3	13,0	250,0	40,0	156,0
1108679	6230-0336	23,0	KM3	16,0	280,0	45,0	186,0
1477238	6230-0337	27,0	KM3	16,0	280,0	30,0	180,0
1108682	6230-0341	32,0	KM4	19,0	300,0	56,0	182,0
115583	—	34,0	KM4	19,0	300,0	50,0	175,0
1254158	—	38,0	KM4	19,0	300,0	50,0	175,0
1103038	6230-0353	55,0	KM5	32,0	380,0	60,0	232,0

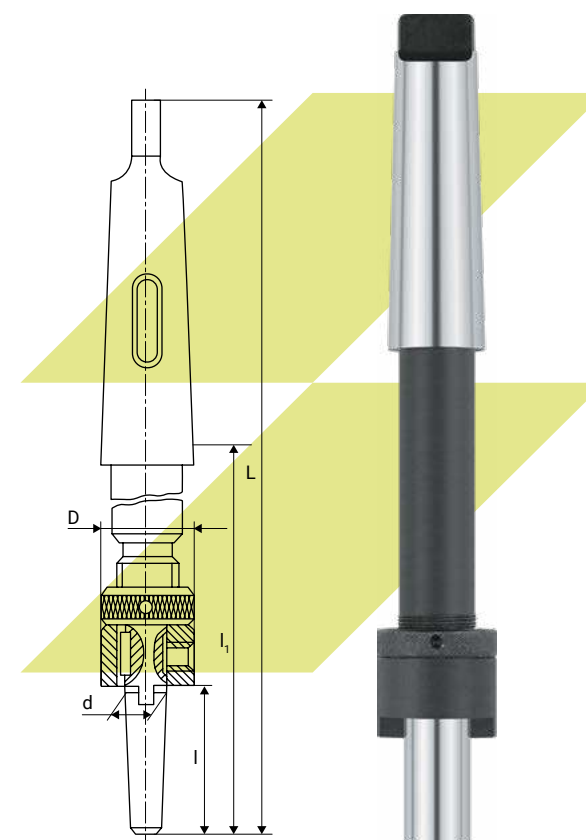

Зенковки центровочные из быстрорежущей стали с углом при вершине 60°

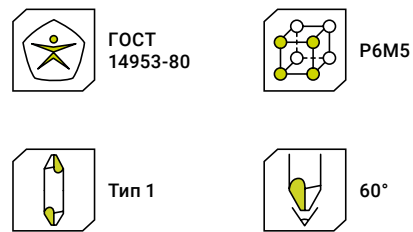

Артикул	Обозначение по ГОСТ	D, мм	l, мм	L, мм	Z, шт
1417439	2353-0081	5,0	10,0	50,0	1
1417446	2353-0082	8,0	12,0	60,0	1

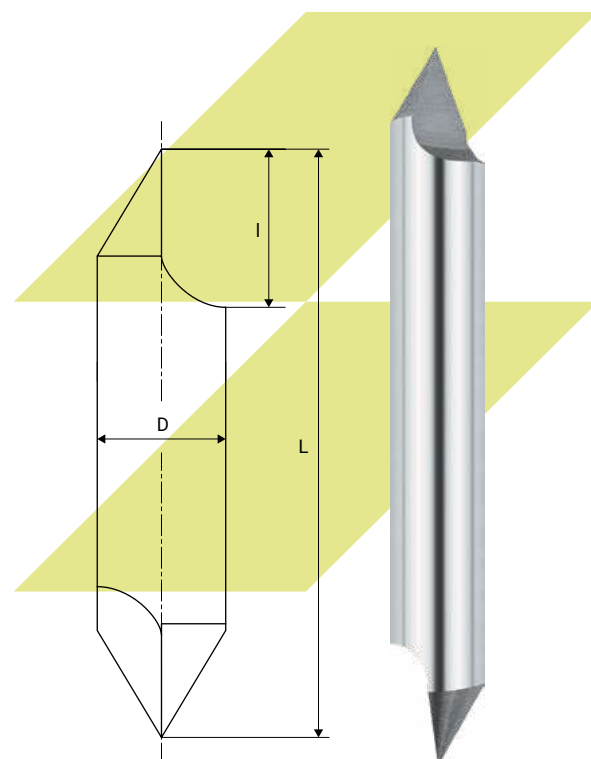

Зенковки центровочные из быстрорежущей стали для центровых отверстий с углом при вершине 60° без предохранительного конуса

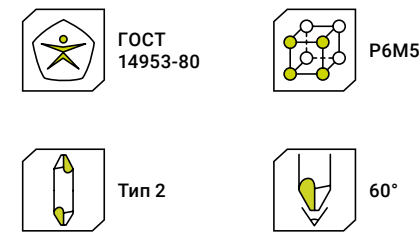

Артикул	Обозначение по ГОСТ	D, мм	d _{min} , мм	l, мм	L, мм	Z, шт
1417440	2353-0083	5,0	2,0	3,0	45,0	2
1417442	2353-0084	6,3	2,5	3,7	50,0	2
1417447	2353-0085	8,0	3,15	4,7	50,0	2
1417450	2353-0086	10,0	4,0	6,0	56,0	2
1417452	2353-0087	12,5	5,0	7,4	63,0	2
1417455	2353-0088	16,0	6,3	9,5	71,0	2

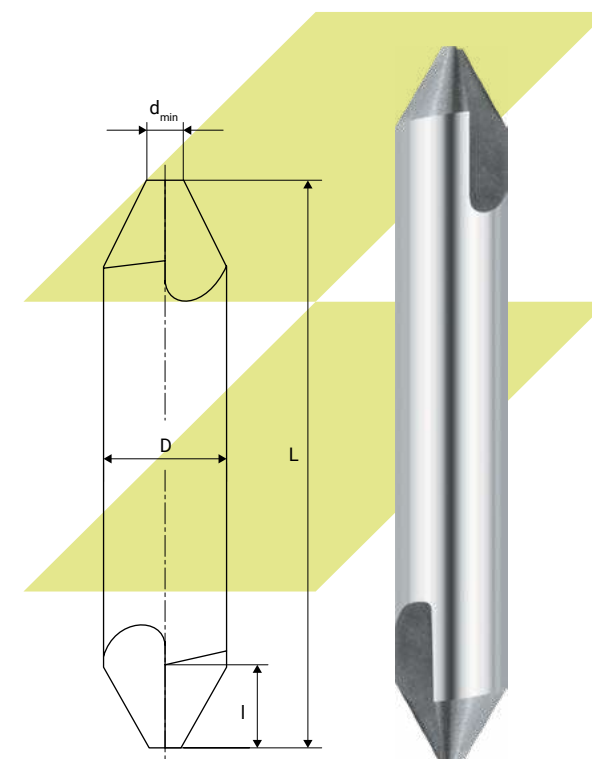

Зенковки центровочные из быстрорежущей стали для центровых отверстий с углом при вершине 60° с предохранительным конусом 120°

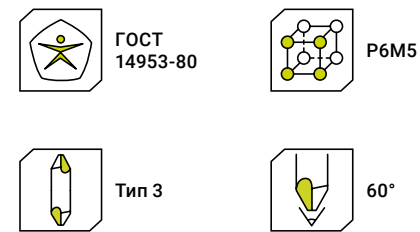

Артикул	Обозначение по ГОСТ	D, мм	d _{min} , мм	l, мм	L, мм	Z, шт
1417441	2357-0001	5,0	0,80	0,82	35,5	2
1417443	2357-0002	6,3	1,00	1,13	35,5	2
1417445	2357-0003	7,1	1,25	1,21	40,0	2
1417448	2357-0004	8,0	1,60	1,52	45,0	2
1417451	2357-0005	10,0	2,00	2,20	45,0	2
1417453	2357-0006	12,5	2,50	2,60	50,0	2
1417454	2357-0007	14,0	3,15	3,30	50,0	2
1417456	2357-0008	16,0	4,00	4,20	56,0	2
1417457	2357-0009	20,0	5,00	5,20	63,0	2
1417458	2357-0010	25,0	6,30	6,50	71,0	2

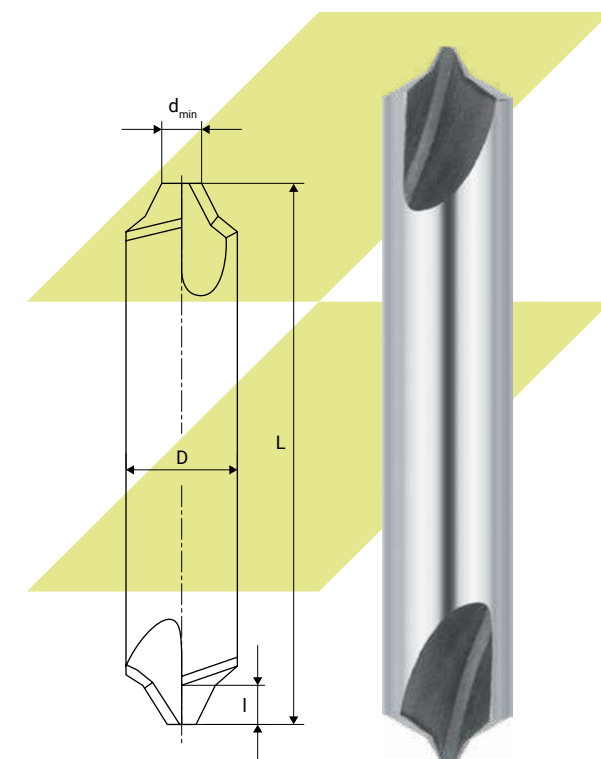

Зенковки центровочные из быстрорежущей стали для центровых отверстий с углом при вершине 75° без предохранительного конуса

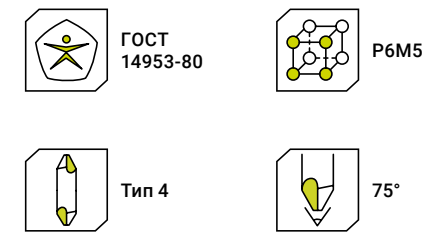

Артикул	Обозначение по ГОСТ	D, мм	d _{min} , мм	l, мм	L, мм	Z, шт
1417444	2353-0089	6,3	2,0	3,10	45,0	2
1417449	2353-0090	8,0	2,5	3,90	50,0	2

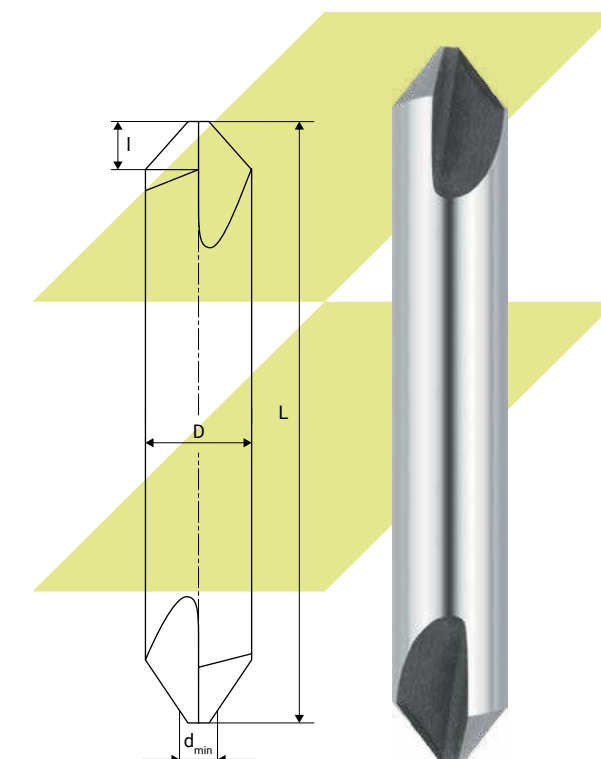

Зенковки из быстрорежущей стали с углом при вершине 60° с цилиндрическим хвостовиком

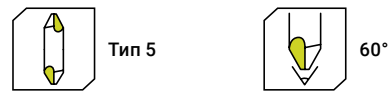
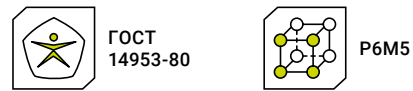

Артикул	Обозначение по ГОСТ	D, мм	d _{min} ', мм	l, мм	L, мм	Z, шт
1253875	2353-0101	8,0	1,6	16,0	48,0	4
1253877	2353-0102	10,0	2,0	18,0	50,0	4
1253879	2353-0103	12,5	2,5	20,0	50,0	4
1585391	2353-0104	16,0	3,2	24,0	60,0	6
1418498	2353-0105	20,0	4,0	28,0	64,0	6
1585392	2353-0106	25,0	7,0	33,0	69,0	4

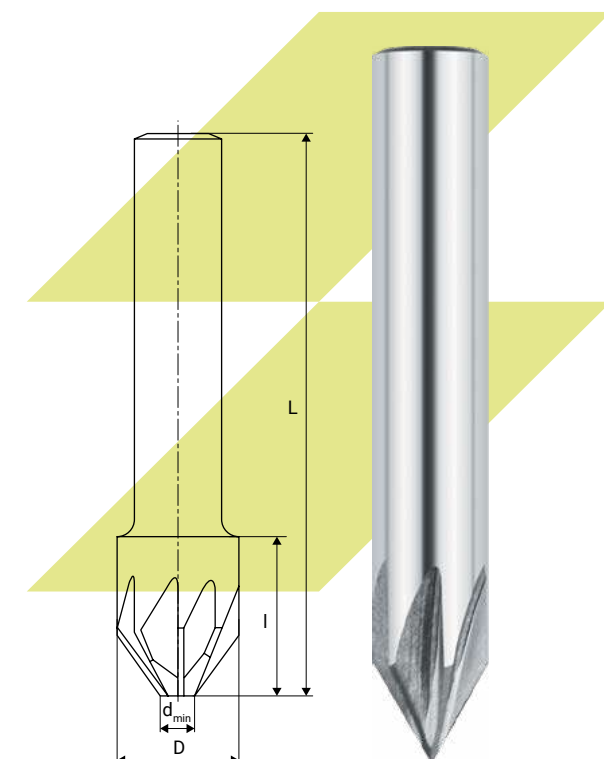

Зенковки из быстрорежущей стали с углом при вершине 90° с цилиндрическим хвостовиком

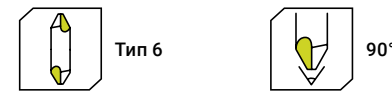
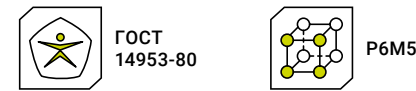

Артикул	Обозначение по ГОСТ	D, мм	d _{min} ', мм	l, мм	L, мм	Z, шт
1264125	—	5,0	1,6	5,00	45,0	4
1253851	2353-0107	8,0	1,6	12,0	44,0	4
1253662	2353-0108	10,0	2,0	14,0	46,0	4
1253880	2353-0109	12,5	2,5	16,0	48,0	4
1236396	2353-0111	16,0	3,2	20,0	56,0	4
1254060	2353-0112	20,0	4,0	24,0	60,0	6
1254061	2353-0113	25,0	7,0	29,0	65,0	6

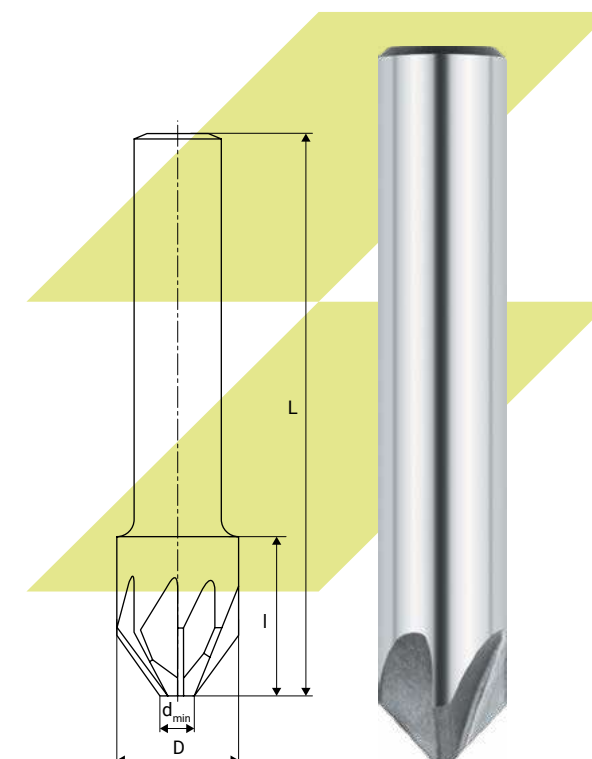

Зенковки из быстрорежущей стали с углом при вершине 120° с цилиндрическим хвостовиком



ГОСТ
14953-80



P6M5



Тип 7



120°

Артикул	Обозначение по ГОСТ	D, мм	d _{min} , мм	l, мм	L, мм	Z, шт
1253876	2353-0114	8,0	1,6	12,0	44,0	4
1253878	2353-0115	10,0	2,0	14,0	46,0	4
1253881	2353-0116	12,5	2,5	16,0	48,0	4
1585390	2353-0117	16,0	3,2	20,0	56,0	4
1276308	2353-0118	20,0	4,0	24,0	60,0	6
1585616	2353-0119	25,0	7,0	29,0	65,0	6

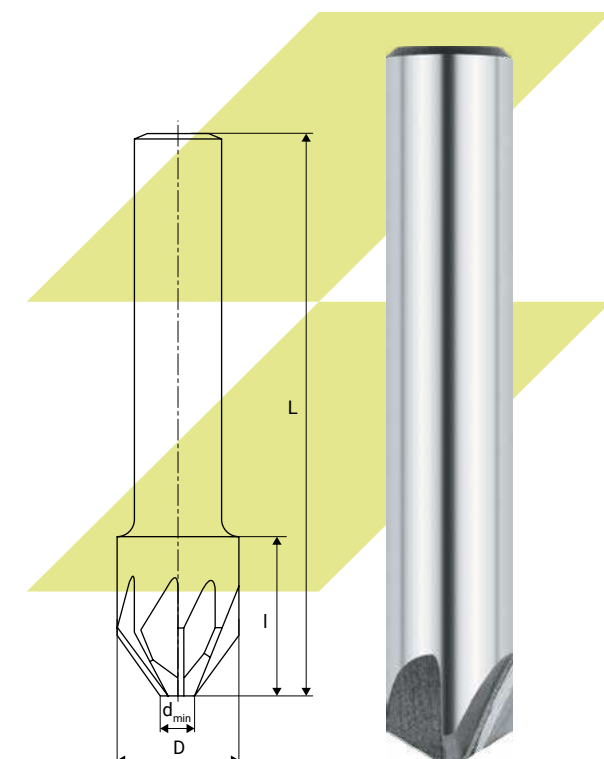

Зенковки из быстрорежущей стали с углом при вершине 60° с коническим хвостовиком



ГОСТ
14953-80

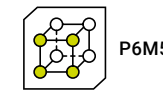

P6M5



Тип 8



60°

Артикул	Обозначение по ГОСТ	D, мм	d _{min} , мм	KM	l, мм	L, мм	Z, шт
1240446	2353-0121	16,0	3,2	KM1	24,0	97,0	4
1144148	2353-0122	20,0	4,0	KM2	28,0	120,0	6
1240448	2353-0123	25,0	7,0	KM2	33,0	125,0	6
1240451	2353-0124	31,5	9,0	KM2	40,0	132,0	8
1144151	2353-0125	40,0	12,5	KM3	45,0	160,0	8
1144154	—	45,0	16,0	KM3	45,0	160,0	8
1144157	2353-0126	50,0	16,0	KM3	50,0	165,0	8
1477081	2353-0127	63,0	20,0	KM4	58,0	200,0	8
1144162	2353-0128	80,0	25,0	KM4	73,0	215,0	10

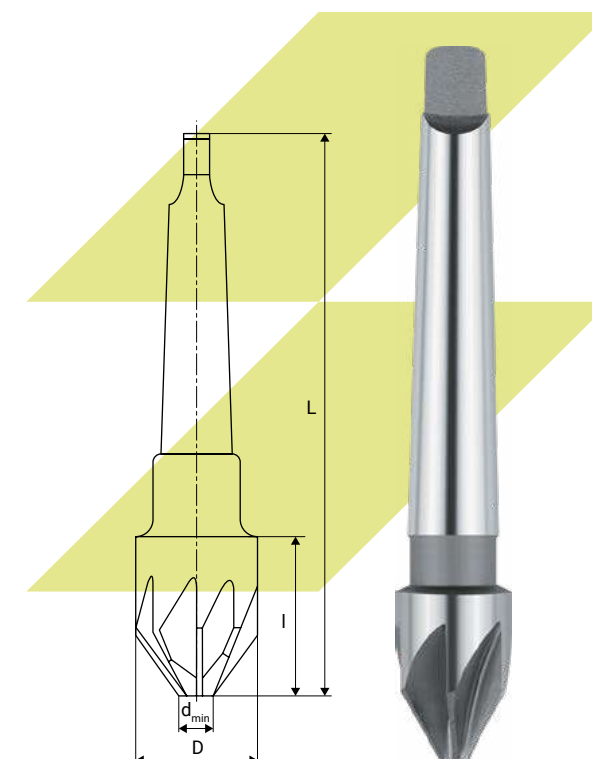

Зенковки из быстрорежущей стали с углом при вершине 90° с коническим хвостовиком

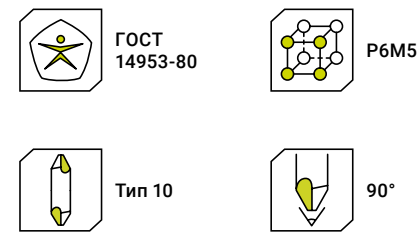

Артикул	Обозначение по ГОСТ	D, мм	d _{min} , мм	KM	I, мм	L, мм	Z, шт
1144147	2353-0133	16,0	3,2	KM1	20,0	93,0	4
1144149	2353-0134	20,0	4,0	KM2	24,0	116,0	6
1240449	2353-0135	25,0	7,0	KM2	29,0	121,0	6
1220038	2353-0136	31,5	9,0	KM2	32,0	124,0	8
1220039	—	32,0	—	KM2	32,0	124,0	8
1417892	2353-0137	40,0	12,5	KM3	35,0	150,0	8
1144155	—	45,0	—	KM3	40,0	155,0	8
1144158	2353-0138	50,0	16,0	KM3	38,0	153,0	8
1289522	2353-0139	63,0	20,0	KM4	43,0	185,0	8
1144163	2353-0141	80,0	25,0	KM4	54,0	196,0	10

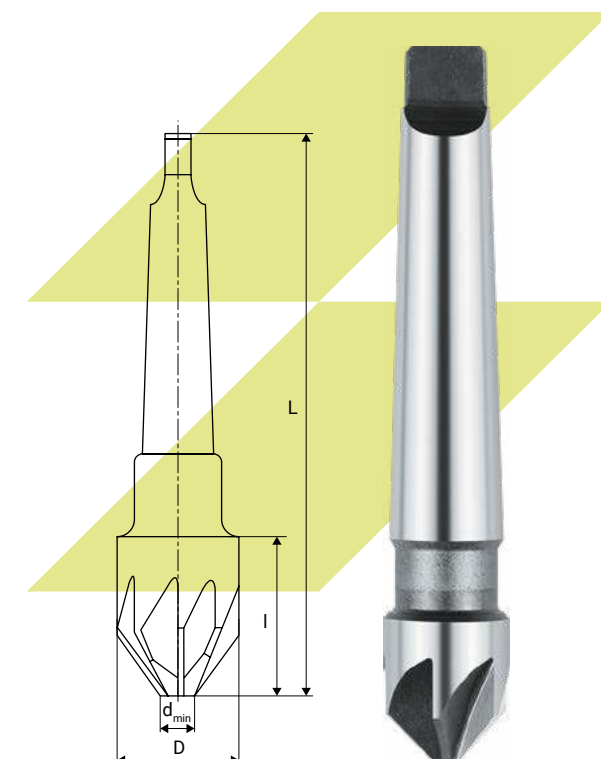

Зенковки из быстрорежущей стали с углом при вершине 120° с коническим хвостовиком

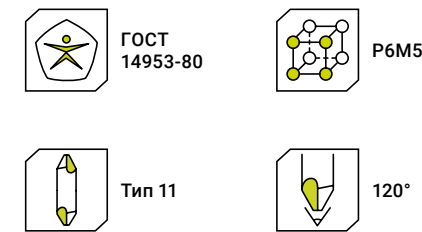

Артикул	Обозначение по ГОСТ	D, мм	d _{min} , мм	KM	I, мм	L, мм	Z, шт
1240447	2353-0142	16,0	3,2	KM1	20,0	93,0	4
1144150	2353-0143	20,0	4,0	KM2	24,0	116,0	6
1240450	2353-0144	25,0	7,0	KM2	29,0	121,0	6
1240452	2353-0145	31,5	9,0	KM2	32,0	124,0	8
100598	—	32,0	—	KM2	32,0	135,0	8
1144153	2353-0146	40,0	12,5	KM3	35,0	150,0	8
1144156	—	45,0	—	KM3	40,0	155,0	8
1144159	2353-0147	50,0	16,0	KM3	38,0	153,0	8
1144164	2353-0149	80,0	25,0	KM4	54,0	196,0	10

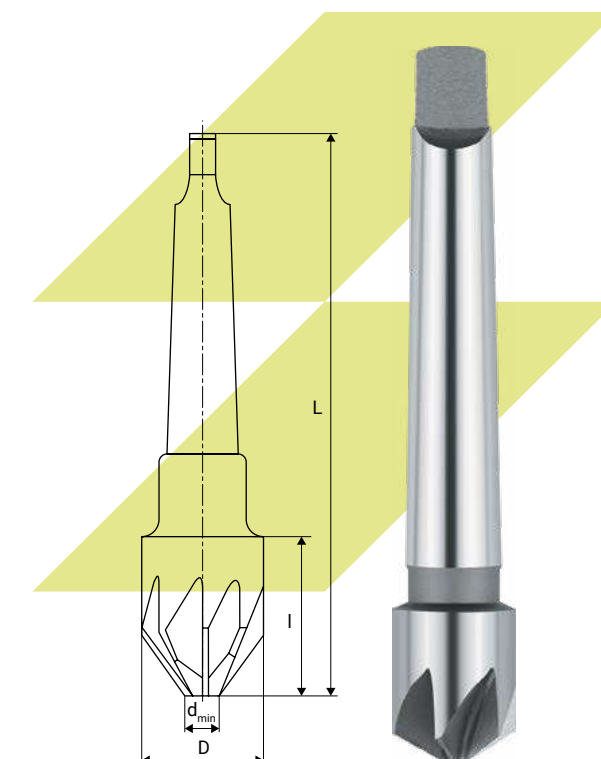



Фрезерование

Фрезы концевые	310
С цилиндрическим хвостовиком	310
С коническим хвостовиком	337
Для обработки пазов	364
Фрезы дисковые	381
Трехсторонние	381
Пазовые	394
Угловые	396
Фрезы фасонные	398
Полукруглые выпуклые	398
Полукруглые вогнутые	399
Фрезы насадные торцовые	400
Со вставными ножами	400
Со сменными неперетачиваемыми пластинами	406
Из быстрорежущей стали	411

Фрезы концевые

Концевые фрезы используются преимущественно на ручных копировально-фрезерных станках для изготовления уступов и пазов в труднообрабатываемых материалах, легких сплавах и др., а также для обработки закрытых контуров и пазов. Рекомендуются для обработки по контуру, фрезерования стенок и неглубоких канавок. Обеспечивают высокую точность, чистоту и качество фрезерования. Устойчивы к выщерблению по кромке режущей части.



Фрезы дисковые

Дисковые фрезы предназначены для прорезки прямых шлицев, пазов и отрезных работ в изделиях из чугуна, черных и цветных металлов, сплавов стали, для создания прямоугольных пазов, уступов. Используются для оснащения универсальных фрезерных и токарных станков, в том числе с ЧПУ, а также могут быть установлены на бормашину, гравер, дрель или ручной фрезер.

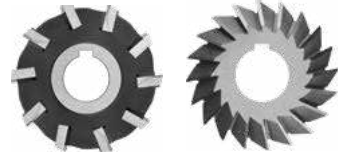

Фрезы фасонные

Фасонные фрезы по металлу применяются при обработке поверхностей незамкнутого типа и создания канавок. Позволяют образовать сложный фасонный профиль. Подходят для обработки металлических поверхностей заготовок, имеющих значительную разницу между длиной и шириной.

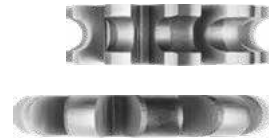

Фрезы насадные торцевые

Насадные торцевые фрезы применяются в процессе обработки металлических поверхностей для создания пазов и выемок различного вида. Предназначены для скоростного фрезерования уступов, торцевого, контурного фрезерования и фрезерования наклонных поверхностей. Фрезы имеют большое количество зубьев, что позволяет добиться высокой эффективности обработки металла. Кромки с торца предназначены для выполнения вспомогательной резки.



Условные обозначения

Основные размеры

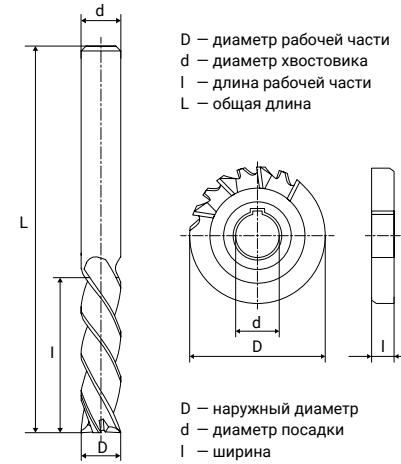

Тип обработки

- Для фрезерования торца
- Для фрезерования уступов
- Для фрезерования пазов
- Для фрезерования пазов типа «ласточкин хвост»
- Для фрезерования T-образных пазов
- Для фрезерования фасок
- Для фрезерования угла
- Для фасонного фрезерования
- Для фасонного фрезерования
- Для фрезерования пазов типа перевернутый «ласточкин хвост»

Обрабатываемый материал

- P** Стали
- M** Нержавеющая сталь
- K** Чугуны
- N** Цветные металлы
- S** Жаропрочные сплавы
- H** Закаленная сталь
- Оптимальное применение
- Возможное применение
- Не применяется

- Обозначение стандарта
- Обозначение инструментального материала
- Покрытие
- Тип ножа/пластины
- Угол наклона винтовой канавки
- Количество зубьев

Серия инструмента

- Средняя
- Длинная
- Сверхдлинная

Угол при вершине

- Ножа
- Пластины

Наличие инструмента

- На складе в Нижнем Новгороде
- Под заказ

Фрезы концевые из быстрорежущей стали

Вид обработки	С цилиндрическим хвостовиком для легких сплавов		С цилиндрическим хвостовиком				
Стандарт	ГОСТ 16225-81	ГОСТ 16225-81	ГОСТ 32831-2014	ГОСТ 32831-2014	ГОСТ 32831-2014	ГОСТ 32831-2014	ГОСТ 32831-2014
Серия	Средняя	Длинная	Средняя	Средняя	Средняя	Средняя	Средняя
Материал	P6M5	P6M5	P6M5	P6M5	P6M5K5	P6M5K5	P18
Количество зубьев	2-3	2-3	2-4	3-6	3-4	4-6	2-4
Диапазон	3,0-12,0	4,0-12,0	2,0-28,0	2,0-28,0	3,0-20,0	3,0-20,0	2,0-20,0
Страница	310	311	312	314	316	317	318



Вид обработки	С цилиндрическим хвостовиком						Фрезы двусторонние
Стандарт	ГОСТ 32831-2014	ГОСТ 32831-2014	ГОСТ 32831-2014	ГОСТ 32831-2014	ГОСТ 32831-2014	DIN 844	ТУ 3-809-87
Серия	Средняя	Длинная	Длинная	Длинная	Длинная	Сверхдлинная	Средняя
Материал	P18	P6M5	P6M5	P6M5K5	P6M5K5	P6M5	P6M5
Количество зубьев	3-6	3-5	4-6	3-4	4-6	3-5	3-4
Диапазон	2,0-28,0	4,0-20,0	4,0-28,0	3,0-20,0	3,0-20,0	6,0-16,0	3,0-12,0
Страница	319	320	321	322	323	324	325



Фрезы концевые твердосплавные цельные

Вид обработки	С цилиндрическим хвостовиком						
Стандарт	ГОСТ 32405-2013	ГОСТ 18372-73	ГОСТ 18372-73	DIN 6527	DIN 6527	DIN 6527	—
Серия	Средняя	Средняя	Средняя	Средняя	Средняя	Средняя	Средняя
Материал	BK8	BK8	T5K10	BK8	BK8 (TiAlN)	BK10	BK10
Количество зубьев	3-4	3-5	3-5	3-5	3-5	3	4
Диапазон	2,0-20,0	3,0-12,0	6,0-12,0	1,0-25,0	1,0-12,0	1,0-20,0	1,0-20,0
Страница	326	327	328	329	330	331	332



Фрезы концевые твердосплавные цельные

Вид обработки	С цилиндрическим хвостовиком	
Стандарт	—	—
Серия	Длинная	Средняя
Материал	BK10	ZK40SF
Количество зубьев	4	4
Диапазон	3,0-20,0	1,0-20,0
Страница	333	334



Фрезы концевые оснащённые винтовыми твердосплавными пластинами

Вид обработки	С цилиндрическим хвостовиком	
Стандарт	ГОСТ 20536-75	ГОСТ 20536-75
Серия	Средняя	Средняя
Материал	BK8	T5K10
Количество зубьев	2-4	2-4
Диапазон	10,0-20,0	10,0-20,0
Страница	335	336

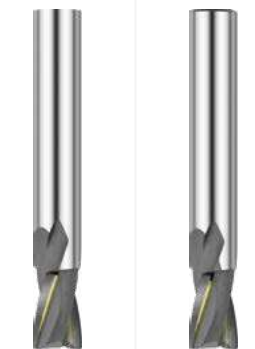

Фрезы концевые из быстрорежущей стали

	С коническим хвостовиком						
Вид обработки							
Стандарт	ГОСТ 32831-2014*	ГОСТ 32831-2014*	ГОСТ 32831-2014*	ГОСТ 32831-2014*	DIN 845	ГОСТ 32831-2014*	ГОСТ 32831-2014*
Серия	Средняя	Средняя	Средняя	Средняя	Средняя	Длинная	Длинная
Материал	P6M5	P6M5	P18	P18	P6M5K5	P6M5	P6M5
Количество зубьев	4-8	3-5	4-8	3-4	3-8	4-8	3-5
Диапазон	10,0-63,0	10,0-63,0	12,0-63,0	12,0-50,0	8,0-63,0	10,0-63,0	10,0-63,0
Страница	337	339	341	342	343	344	346

	С коническим хвостовиком			С коническим хвостовиком для обработки легких сплавов	С коническим хвостовиком для обработки деталей из высокопрочных сталей и титановых сплавов
Вид обработки					
Стандарт	ГОСТ 32831-2014*	ГОСТ 32831-2014*	DIN 845	ГОСТ 16225-81	ГОСТ 23248-78
Серия	Длинная	Длинная	Длинная	Средняя/Длинная	Средняя/Длинная/Сверхдлинная
Материал	P18	P18	P6M5K5	P6M5	P6M5K5
Количество зубьев	4-8	3-4	3-6	2-3	3-6
Диапазон	10,0-63,0	12,0-50,0	10,0-70,0	8,0-50,0	8,0-50,0
Страница	348	349	360	350	351

Фрезы концевые оснащённые прямыми и винтовыми твёрдосплавными пластинами

	С коническим хвостовиком с прямыми пластинами		Диаметром от 12,5 до 50 мм с коническим хвостовиком с винтовыми пластинами		
Вид обработки					
Стандарт	ТУ 2-035-591-77	ТУ 2-035-591-77	ГОСТ 20537-75	ГОСТ 20537-75	ГОСТ 20537-75
Серия	Средняя	Средняя	Средняя	Средняя	Средняя
Материал	ВК8	T5K10	ВК8	T5K10	T15K6
Количество зубьев	4-8	4-8	2-6	2-6	2-6
Диапазон	10,0-80,0	10,0-80,0	12,5-50,0	12,5-50,0	20,0-50,0
Страница	353	354	355	356	357

	Диаметром от 20 до 50 мм с коническим хвостовиком			С коническим хвостовиком для обработки деталей из высокопрочных сталей и титановых сплавов		
Вид обработки						
Стандарт	ГОСТ 20538-75	ГОСТ 20538-75	ГОСТ 20538-75	ГОСТ 24637-81	ГОСТ 24637-81	ГОСТ 24637-81
Серия	Средняя	Средняя	Средняя	Средняя/Длинная/Сверхдлинная	Средняя/Длинная/Сверхдлинная	Средняя/Длинная/Сверхдлинная
Материал	ВК8	T5K10	T15K6	ВК8	T5K10	T15K6
Количество зубьев	4-6	4-6	4-6	3-6	3-6	4-6
Диапазон	20,0-50,0	20,0-50,0	20,0-50,0	16,0-55,0	16,0-50,0	20,0-50,0
Страница	358	359	360	361	362	363

Фрезы концевые для обработки пазов

Вид обработки	Шпоночные с цилиндрическим хвостовиком		Шпоночные, оснащённые твердосплавными пластинами с цилиндрическим хвостовиком		Шпоночные цельные твердосплавные
Стандарт	ГОСТ 9140-2015	ГОСТ 9140-2015	ГОСТ 6396-78	ГОСТ 6396-78	ГОСТ 16463-2016
Серия	Средняя	Средняя	Средняя	Средняя	Средняя
Материал	P6M5	P18	ВК8	T5K10	ВК8
Количество зубьев	2	2	2	2	2
Диапазон	1,7–25,0	2,0–25,0	10,0–20,0	10,0–20,0	2,0–12,0
Страница	364	366	367	368	369



Фрезы концевые для обработки пазов

Вид обработки	Для обработки пазов сегментных шпонок с цилиндрическим хвостовиком из быстрорежущей стали	Для обработки Т-образных пазов с цилиндрическим хвостовиком из быстрорежущей стали	Для обработки Т-образных пазов с коническим хвостовиком	
Стандарт	ГОСТ Р 53412-2009	ГОСТ 7063-72	ГОСТ 7063-72	ГОСТ 10673-75
Серия	—	—	—	—
Материал	P6M5	P6M5	P6M5	ВК8
Количество зубьев	6–10	6–8	4–8	4–8
Диапазон	4,0–38,0	11,0–60,0	12,5–95,0	18,0–95,0
Страница	377	378	379	380



Вид обработки	Шпоночные с коническим хвостовиком из быстрорежущей стали			Шпоночные с коническим хвостовиком, оснащённые твердосплавными пластинами		Для обработки пазов типа «Ласточкин хвост» из быстрорежущей стали	
Стандарт	ГОСТ 9140-2015	ГОСТ 9140-2015	ГОСТ 9140-2015	ГОСТ 6396-78	ГОСТ 6396-78	ГОСТ Р 52967-2008 С	ГОСТ Р 52967-2008 D
Серия	Средняя	Средняя	Длинная	Средняя	Средняя	—	—
Материал	P6M5	P18	P6M5	ВК8	T5K10	P6M5	P6M5
Количество зубьев	2	2	2	2	2	6–14	6–14
Диапазон	8,0–50,0	10,0–40,0	10,0–50,0	12,0–50,0	12,0–40,0	16,0–40,0	16,0–40,0
Страница	370	371	372	373	374	375	376



Фрезы трехсторонние

Вид обработки	Дисковые трехсторонние		Дисковые трехсторонние со впресованными ножами	Дисковые трехсторонние со сменными ножами	Сменные ножи для фрез дисковых трехсторонних
Стандарт	ГОСТ 28527-90	ГОСТ 28527-90	ГОСТ 1669-78 (H401-66)	ГОСТ 1669-78 (H401-66)	ГОСТ 16228-81
Тип	Тип 1	Тип 2	—	—	2020-
Материал	P6M5	P6M5	P6M5	P6M5	P6M5
Количество зубьев	14–28	2x6–2x11	14–24	10–24	—
Диапазон	50,0–200,0	50,0–125,0	100,0–200,0	100,0–250,0	100,0–315,0
Страница	381	383	385	386	387



Фрезы трехсторонние

	Дисковые трехсторонние со вставными ножами, оснащёнными твердым сплавом	Ножи, оснащённые твердым сплавом, для трехсторонних дисковых фрез	
Вид обработки			
Стандарт	ГОСТ 5348-69	ГОСТ 14700-69	ГОСТ 14700-69
Тип	—	2026-	2026-
Материал	ВК8	ВК8	T5K10
Количество зубьев	8–14	—	—
Диапазон	100,0–200,0	100,0–315,0	100,0–315,0
Страница	389	390	392

Фрезы пазовые из быстрорежущей стали

	Дисковые пазовые	Дисковые пазовые затылованные
Вид обработки		
Стандарт	ГОСТ 3964-69	ГОСТ 8543-71
Тип	—	—
Материал	P6M5	P6M5
Количество зубьев	14–22	12–14
Диапазон	50,0–125,0	50,0–100,0
Страница	394	395



Фрезы угловые из быстрорежущей стали







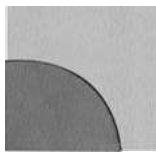

	Одноугловые	Угловые двусторонние
Вид обработки		
Стандарт	ТУ2-035-526-76	ГОСТ Р 50181-92
Тип	—	—
Материал	P6M5	P6M5
Количество зубьев	20–22	20–24
Диапазон	45°–105°	45°–90°
Страница	396	397

Фрезы фасонные полукруглые из быстрорежущей стали











	Выпуклые	Вогнутые
Вид обработки		
Стандарт	ГОСТ 9305-2014	ГОСТ 9305-2014
Тип	—	—
Материал	P6M5	P6M5
Количество зубьев	10–14	10–14
Диапазон	50,0–125,0	50,0–125,0
Страница	398	399

Фрезы насадные торцовые, оснащённые пластинами из твёрдого сплава

	Мелкозубые со вставными ножами	Вставные ножи, оснащённые пластинами из твёрдого сплава
Вид обработки		
Стандарт	ГОСТ 9473-80	ГОСТ 9473-80
Тип	—	2021-
Материал	ВК8	ВК8
Количество зубьев	10–24	
Диапазон	100,0–400,0	100,0–400,0
Страница	400	401
		

	Со вставными ножами	Вставные ножи, оснащённые пластинами из твёрдого сплава		
Вид обработки				
Стандарт	ГОСТ 24359-80	ГОСТ 24359-80	ГОСТ 24359-80	ГОСТ 24359-80
Тип	—	2020-	2020-	2020-
Материал	T5K10	T5K10	ВК8	T15K6
Количество зубьев	8–14	—	—	—
Диапазон	100,0–250,0	100,0–200,0	125,0–160,0	125,0–160,0
Страница	402	403	404	405
				

Фрезы насадные торцовые со сменными неперетачиваемыми пластинами

	С механическим креплением многогранных пластин	Пластины режущие сменные многогранные твердосплавные пятигранной формы с отверстием			Пластины режущие сменные многогранные безвольфрамовые
Вид обработки					
Стандарт	ГОСТ 26595-85	ГОСТ 19064-80	ГОСТ 19064-80	ГОСТ 19064-80	ГОСТ 19051-80
Тип	—	PNUA (10113) PNUM (10114)	PNUA (10113) PNUM (10114)	PNUA (10113) PNUM (10114)	03113-120408
Материал	—	T5K10	ВК8	T15K6	КНТ-16
Количество зубьев	8–18	—	—	—	—
Диапазон	80,0–315,0	80,0–315,0	80,0–315,0	80,0–315,0	100,0–200,0
Страница	406	407	408	409	410
					

Фрезы насадные торцовые

	Из быстрорежущей стали
Вид обработки	
Стандарт	ГОСТ 9304-69
Тип	—
Материал	P6M5
Количество зубьев	8,0–18,0
Диапазон	32,0–100,0
Страница	410
	

Фрезы концевые с цилиндрическим хвостовиком для легких сплавов. Средняя серия

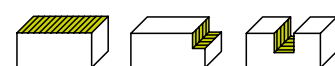

Артикул	Обозначение по ГОСТ	D, мм	d, мм	l, мм	L, мм	Z, шт
1178694	2220-0513	3,0	3,0	8,0	36,0	2
1178766	—	3,0	3,0	8,0	36,0	3
1378629	—	3,0	6,0	8,0	36,0	3
1258328	2220-0515	4,0	4,0	11,0	43,0	2
1378630	—	4,0	6,0	11,0	43,0	2
1258331	2220-0519	5,0	5,0	13,0	47,0	2
1378633	—	5,0	6,0	13,0	47,0	2
1258335	2220-0523	6,0	6,0	16,0	52,0	2
1258337	2220-0527	8,0	8,0	19,0	59,0	2
1258340	2220-0531	10,0	10,0	22,0	72,0	2
1258343	2220-0535	12,0	12,0	26,0	81,0	2

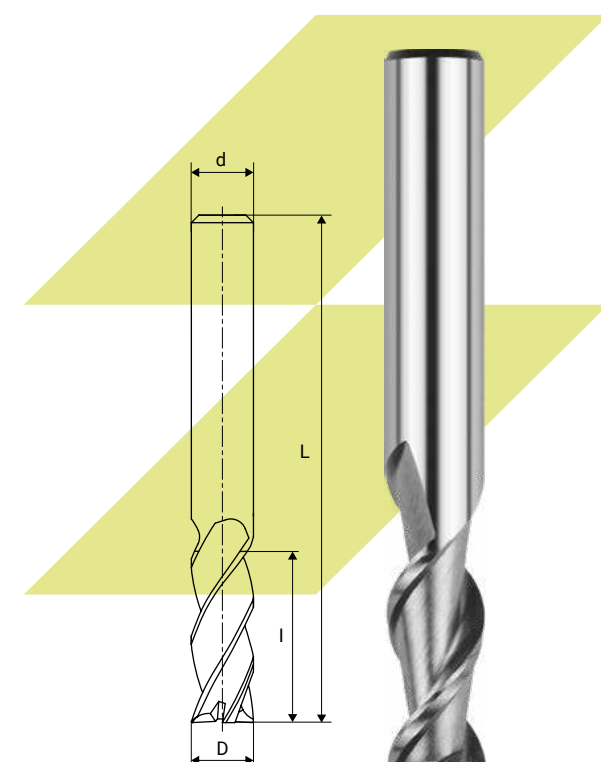

Фрезы концевые с цилиндрическим хвостовиком для легких сплавов. Длинная серия

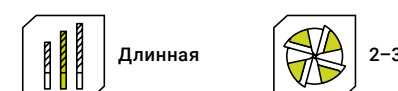
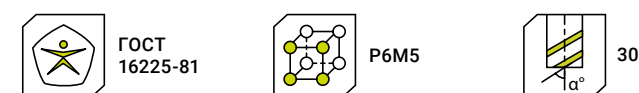
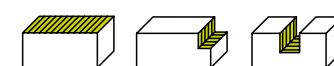

Артикул	Обозначение по ГОСТ	D, мм	d, мм	l, мм	L, мм	Z, шт
1258330	2220-0517	4,0	6,0	19,0	51,0	2
1267733	—	4,0	6,0	19,0	51,0	3
1178768	—	5,0	5,0	24,0	58,0	3
1258333	2220-0521	5,0	6,0	24,0	58,0	2
1378636	—	5,0	6,0	24,0	58,0	3
1258336	2220-0525	6,0	6,0	30,0	66,0	2
1178769	—	6,0	6,0	30,0	66,0	3
1258339	2220-0529	8,0	8,0	38,0	78,0	2
1178770	—	8,0	8,0	38,0	78,0	3
1258342	2220-0533	10,0	10,0	45,0	95,0	2
1178771	—	10,0	10,0	45,0	95,0	3
1258345	2220-0537	12,0	12,0	53,0	108,0	2
1178772	—	12,0	12,0	53,0	108,0	3

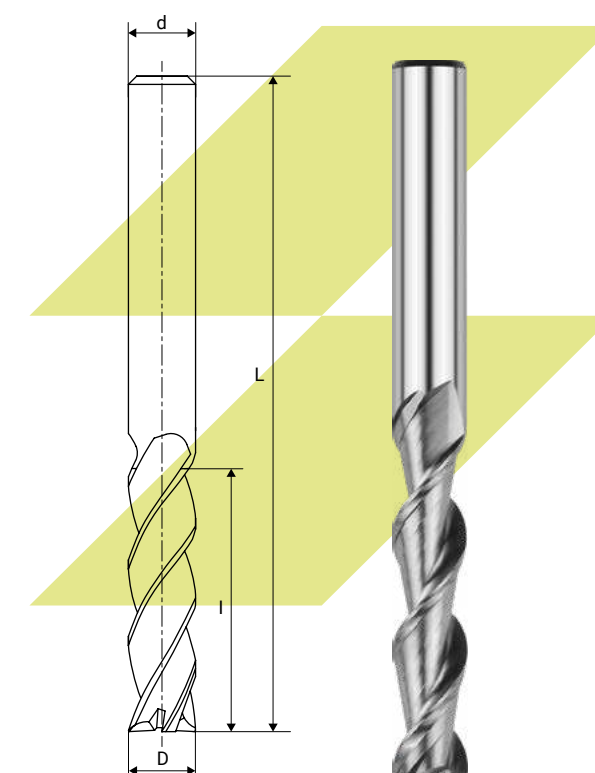

Фрезы концевые с цилиндрическим хвостовиком. Средняя серия

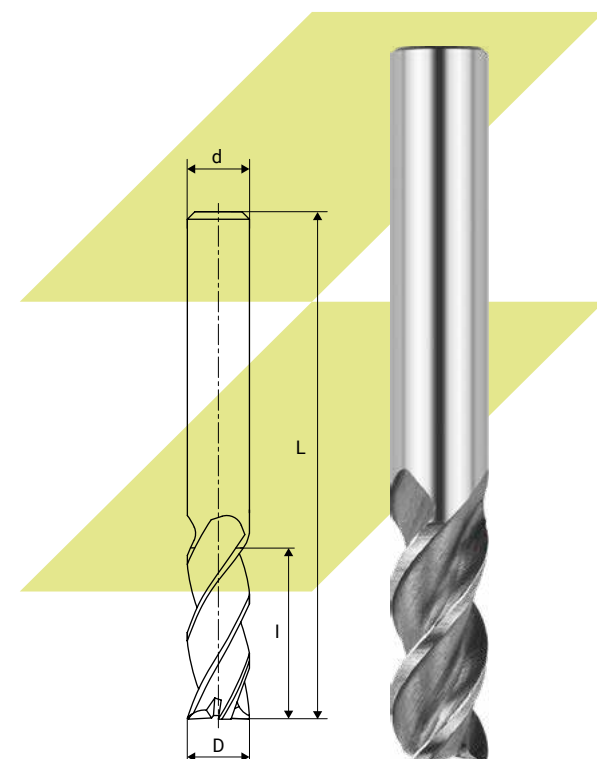
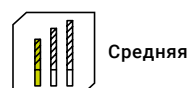
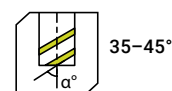

Артикул	Обозначение по ГОСТ	D, мм	d, мм	l, мм	L, мм	Z, шт
1174775	—	2,0	2,0	7,0	39,0	2
1378623	2220-0168	2,0	4,0	7,0	39,0	2
1174777	—	2,5	2,5	8,0	40,0	2
1378625	2220-0177	2,5	4,0	8,0	40,0	2
1378626	—	2,5	6,0	8,0	40,0	2
1262959	—	3,0	3,0	8,0	40,0	3
1343038	2220-0061	3,0	4,0	8,0	40,0	3
1343040	2220-0186	3,5	4,0	10,0	42,0	3
1178222	—	4,0	4,0	11,0	43,0	3
1178224	2220-0065	5,0	5,0	13,0	47,0	3
1378634	—	5,0	5,0	13,0	57,0	3
1425767	—	5,0	6,0	13,0	57,0	3
1172652	2220-0067	6,0	6,0	13,0	57,0	3
1477591	—	7,0	7,0	16,0	60,0	3
1174779	2220-0235	7,0	8,0	16,0	60,0	3
1174780	2220-0069	8,0	8,0	19,0	63,0	3
1243983	—	9,0	8,0	19,0	69,0	3
1378729	2220-0237	9,0	10,0	19,0	69,0	3
1172697	2220-0071	10,0	10,0	22,0	72,0	3
1178229	—	11,0	10,0	22,0	79,0	3
1379122	2220-0239	11,0	12,0	22,0	79,0	3
1172728	—	12,0	12,0	26,0	83,0	3
1172730	2220-0073	12,0	12,0	26,0	83,0	4
1185088	—	13,0	12,0	26,0	83,0	4
1379445	—	13,0	14,0	26,0	83,0	4
1172750	—	14,0	14,0	26,0	83,0	3
1172752	—	14,0	14,0	26,0	83,0	4
1172764	—	16,0	16,0	32,0	92,0	3
1172765	—	16,0	16,0	32,0	92,0	4
1172809	—	18,0	18,0	32,0	92,0	4
1178230	—	20,0	20,0	38,0	104,0	3
1172782	—	20,0	20,0	38,0	104,0	4
1264127	—	22,0	20,0	38,0	104,0	3
1172795	—	22,0	20,0	38,0	104,0	4

Артикул	Обозначение по ГОСТ	D, мм	d, мм	l, мм	L, мм	Z, шт
1264129	—	24,0	25,0	45,0	121,0	4
1172802	—	25,0	25,0	45,0	121,0	4
1172806	—	28,0	28,0	45,0	121,0	4

Фрезы концевые с цилиндрическим хвостовиком. Средняя серия

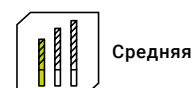
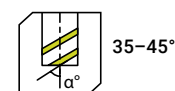
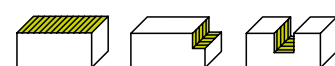

Артикул	Обозначение по ГОСТ	D, мм	d, мм	l, мм	L, мм	Z, шт
1174776	—	2,0	2,0	7,0	39,0	3
1378624	2220-0164	2,0	4,0	7,0	39,0	3
1174778	—	2,5	2,5	8,0	40,0	3
1378627	2220-0173	2,5	4,0	8,0	40,0	3
1378628	—	2,5	6,0	8,0	40,0	3
1343039	2220-0001	3,0	4,0	8,0	40,0	4
1257812	—	3,0	3,0	8,0	40,0	5
1174773	2220-0182	3,5	4,0	10,0	42,0	4
1178223	2220-0003	4,0	4,0	11,0	43,0	4
1178225	2220-0005	5,0	5,0	13,0	47,0	4
1582489	—	5,0	5,0	13,0	47,0	5
1378635	—	5,0	6,0	13,0	57,0	4
1172655	2220-0007	6,0	6,0	13,0	57,0	4
1257813	—	6,0	6,0	13,0	57,0	5
1172669	2220-0429	7,0	8,0	16,0	60,0	4
1518354	—	7,0	7,0	20,0	50,0	4
1178226	2220-0009	8,0	8,0	19,0	63,0	4
1477491	2220-0433	9,0	10,0	19,0	69,0	4
1257814	—	9,0	8,0	19,0	69,0	5
1378730	—	9,0	10,0	19,0	69,0	5
1174774	2220-0011	10,0	10,0	22,0	72,0	4
1254680	—	10,0	10,0	22,0	72,0	5
1254681	—	10,0	10,0	22,0	72,0	6
1416224	—	11,0	10,0	22,0	79,0	4
1172722	2220-0435	11,0	12,0	22,0	79,0	4
1185084	—	11,0	10,0	22,0	79,0	6
1379121	—	11,0	12,0	22,0	79,0	6
1172732	2220-0013	12,0	12,0	26,0	83,0	5
1185086	—	12,0	12,0	26,0	83,0	6
1185089	—	13,0	12,0	26,0	83,0	6
1379446	2220-0015	14,0	12,0	26,0	83,0	5
1172753	—	14,0	14,0	26,0	83,0	5
1337449	—	14,0	14,0	26,0	83,0	6
1172767	2220-0017	16,0	16,0	32,0	92,0	5

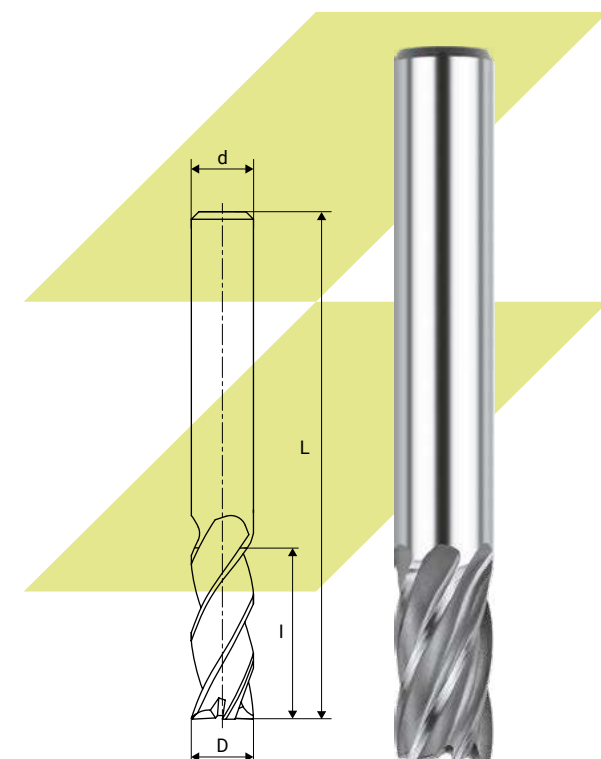

Артикул	Обозначение по ГОСТ	D, мм	d, мм	l, мм	L, мм	Z, шт
1185477	—	16,0	16,0	32,0	92,0	6
1264126	—	18,0	18,0	32,0	92,0	5
1172810	—	18,0	18,0	32,0	92,0	6
1379622	2220-0017	18,0	16,0	32,0	92,0	6
1409756	—	18,0	18,0	48,0	108,0	6
1172783	—	20,0	20,0	38,0	104,0	5
1172784	2220-0021	20,0	20,0	38,0	104,0	6
1264128	—	22,0	20,0	38,0	104,0	5

Артикул	Обозначение по ГОСТ	D, мм	d, мм	l, мм	L, мм	Z, шт
1172799	2220-0208	22,0	20,0	38,0	104,0	6
1409716	—	24,0	20,0	45,0	121,0	5
1264131	—	24,0	20,0	45,0	121,0	6
1264130	—	24,0	25,0	45,0	121,0	5
1409717	—	24,0	25,0	45,0	121,0	6
1172803	2220-0217	25,0	25,0	45,0	121,0	6
1172807	2220-0226	28,0	25,0	45,0	121,0	6

Фрезы концевые с цилиндрическим хвостовиком. Средняя серия

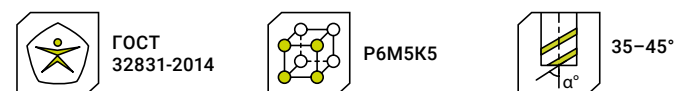
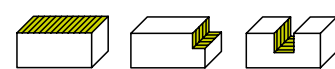

Артикул	Обозначение по ГОСТ	D, мм	d, мм	l, мм	L, мм	Z, шт
1256924	—	3,0	6,0	8,0	40,0	3
1258329	—	4,0	6,0	11,0	43,0	3
1258332	—	5,0	6,0	13,0	47,0	3
1258334	2220-0067	6,0	6,0	13,0	57,0	3
1258338	2220-0070	8,0	8,0	19,0	63,0	3
1258341	2220-0072	10,0	10,0	22,0	72,0	3
1258344	—	12,0	12,0	26,0	83,0	3
1256943	2220-0073	12,0	12,0	26,0	83,0	4
1265463	—	14,0	12,0	26,0	83,0	3
1256947	—	14,0	12,0	26,0	83,0	4
1265464	—	16,0	16,0	32,0	92,0	3
1256951	—	16,0	16,0	32,0	92,0	4
1265465	—	18,0	16,0	32,0	92,0	3
1256955	—	18,0	16,0	32,0	92,0	4
1265466	—	20,0	20,0	38,0	104,0	3
1256959	—	20,0	20,0	38,0	104,0	4

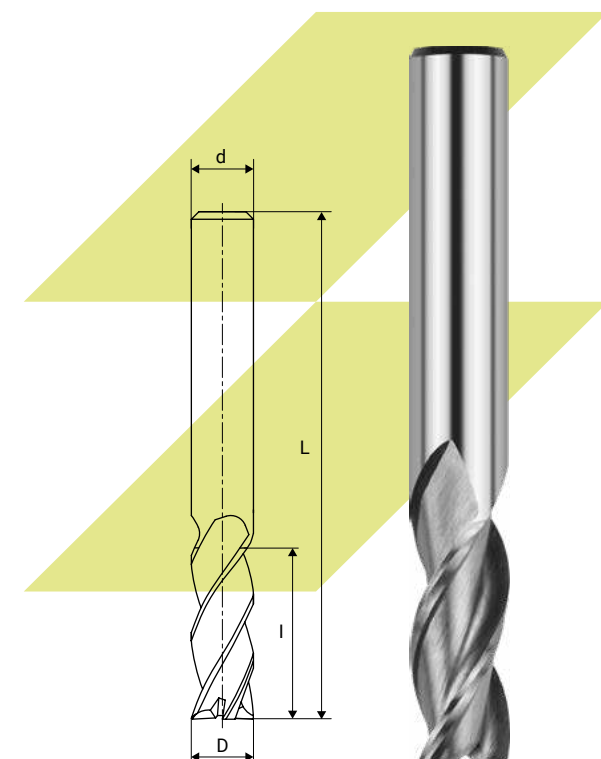

Фрезы концевые с цилиндрическим хвостовиком. Средняя серия

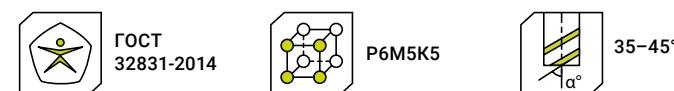
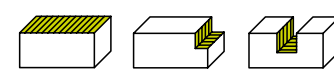

Артикул	Обозначение по ГОСТ	D, мм	d, мм	l, мм	L, мм	Z, шт
1256925	—	3,0	6,0	8,0	40,0	4
1256928	—	4,0	6,0	11,0	43,0	4
1256931	—	5,0	6,0	13,0	47,0	4
1256934	2220-0007	6,0	6,0	13,0	57,0	4
1256937	2220-0009	8,0	8,0	19,0	63,0	4
1256940	2220-0011	10,0	10,0	22,0	72,0	4
1256944	2220-0013	12,0	12,0	26,0	83,0	5
1256948	2220-0015	14,0	12,0	26,0	83,0	5
1256952	2220-0017	16,0	16,0	32,0	92,0	5
1256956	2220-0017	18,0	16,0	32,0	92,0	6
1256960	2220-0021	20,0	20,0	38,0	104,0	6

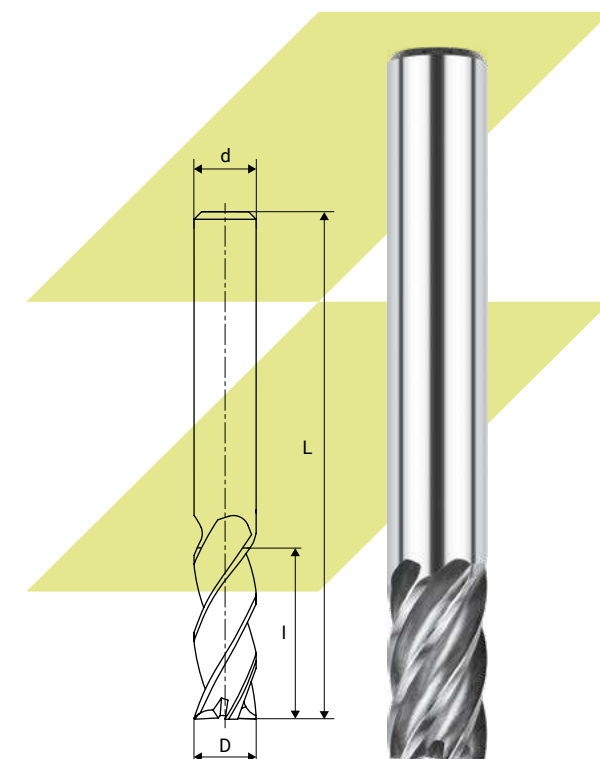

Фрезы концевые с цилиндрическим хвостовиком. Средняя серия

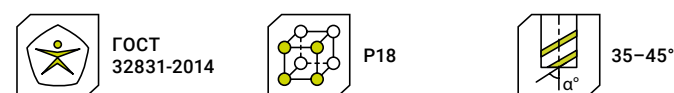
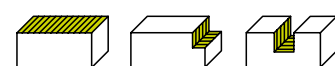

Артикул	Обозначение по ГОСТ	D, мм	d, мм	l, мм	L, мм	Z, шт
1323479	2220-0168	2,0	4,0	7,0	39,0	2
1323481	—	2,5	2,5	8,0	40,0	2
1416475	—	2,5	2,5	15,0	42,0	2
1323483	2220-0061	3,0	4,0	8,0	40,0	3
1323485	2220-0063	4,0	4,0	11,0	43,0	3
1323487	2220-0065	5,0	5,0	13,0	47,0	3
1323489	2220-0067	6,0	6,0	13,0	57,0	3
1323492	2220-0069	8,0	8,0	19,0	63,0	3
1323495	2220-0071	10,0	10,0	22,0	72,0	3
1323499	—	12,0	12,0	26,0	83,0	3
1323500	2220-0073	12,0	12,0	26,0	83,0	4
1323503	—	14,0	14,0	26,0	83,0	4
1323505	—	16,0	16,0	32,0	92,0	4
1323508	—	18,0	18,0	32,0	92,0	4
1323510	—	20,0	20,0	38,0	104,0	4

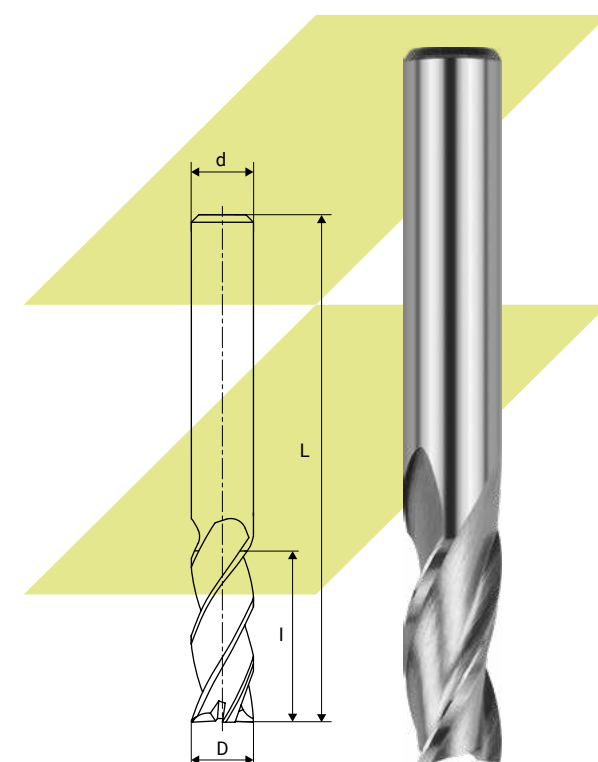

Фрезы концевые с цилиндрическим хвостовиком. Средняя серия

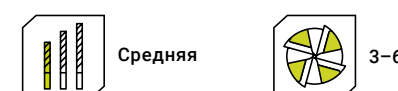
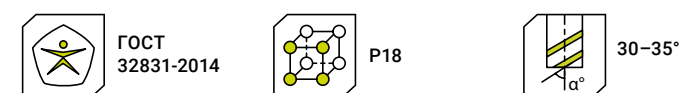
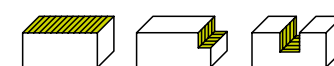

Артикул	Обозначение по ГОСТ	D, мм	d, мм	l, мм	L, мм	Z, шт
1323480	2220-0164	2,0	4,0	7,0	39,0	3
1323482	2220-0173	2,5	4,0	8,0	40,0	3
1323484	2220-0001	3,0	4,0	8,0	40,0	4
1323486	2220-0003	4,0	4,0	11,0	43,0	4
1323488	2220-0005	5,0	5,0	13,0	47,0	4
1172640	—	5,0	5,0	13,0	47,0	5
1323490	2220-0007	6,0	6,0	13,0	57,0	4
1323491	—	6,0	6,0	13,0	57,0	5
1323493	2220-0009	8,0	8,0	19,0	63,0	4
1323494	—	8,0	8,0	19,0	63,0	5
1323496	2220-0011	10,0	10,0	22,0	72,0	4
1323497	—	10,0	10,0	22,0	72,0	5
1323498	—	10,0	10,0	22,0	72,0	6
1323501	2220-0013	12,0	12,0	26,0	83,0	5
1323502	—	12,0	12,0	26,0	83,0	6
1323504	2220-0015	14,0	12,0	26,0	83,0	5
1323506	2220-0017	16,0	16,0	32,0	92,0	5
1323507	—	16,0	16,0	32,0	92,0	6
1323509	2220-0017	18,0	16,0	32,0	92,0	6
1323511	2220-0021	20,0	20,0	38,0	104,0	6
1323512	2220-0208	22,0	20,0	38,0	104,0	6
1323513	—	24,0	25,0	45,0	121,0	6
1323514	2220-0217	25,0	25,0	45,0	121,0	6
1323515	2220-0226	28,0	25,0	45,0	121,0	6

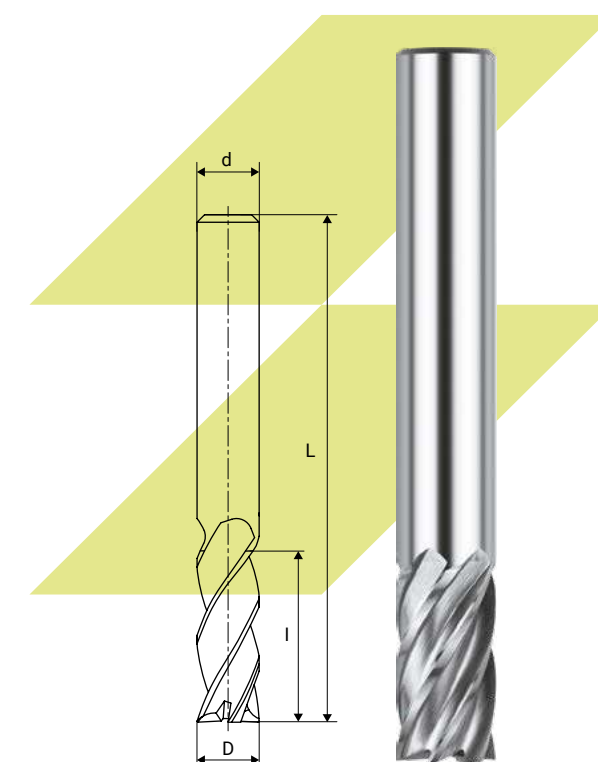

Фрезы концевые с цилиндрическим хвостовиком. Длинная серия

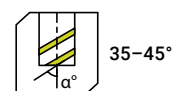
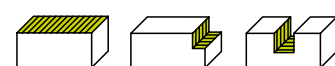

Артикул		D, мм	d, мм	l, мм	L, мм	Z, шт
1172633	●	4,0	4,0	19,0	51,0	3
1378631	●	4,0	6,0	19,0	51,0	3
1172650	●	5,0	6,0	24,0	58,0	3
1172664	●	6,0	6,0	24,0	68,0	3
1178227	●	8,0	8,0	38,0	82,0	3
1178228	●	10,0	10,0	45,0	95,0	3
1377367	●	10,0	10,0	63,0	100,0	3
1416225	●	11,0	10,0	45,0	102,0	4
1172723	●	11,0	12,0	45,0	102,0	4
1172741	●	12,0	12,0	53,0	110,0	3
1172742	●	12,0	12,0	53,0	110,0	4
1172759	●	14,0	14,0	53,0	110,0	3
1379447	●	14,0	12,0	53,0	110,0	3
1172760	●	14,0	14,0	53,0	110,0	4
1379448	●	14,0	12,0	53,0	110,0	4
1172775	●	16,0	16,0	63,0	123,0	3
1172776	●	16,0	16,0	63,0	123,0	4
1172815	●	18,0	18,0	63,0	123,0	4
1379623	●	18,0	16,0	63,0	123,0	4
1178231	●	20,0	20,0	75,0	141,0	3
1172791	●	20,0	20,0	75,0	141,0	4

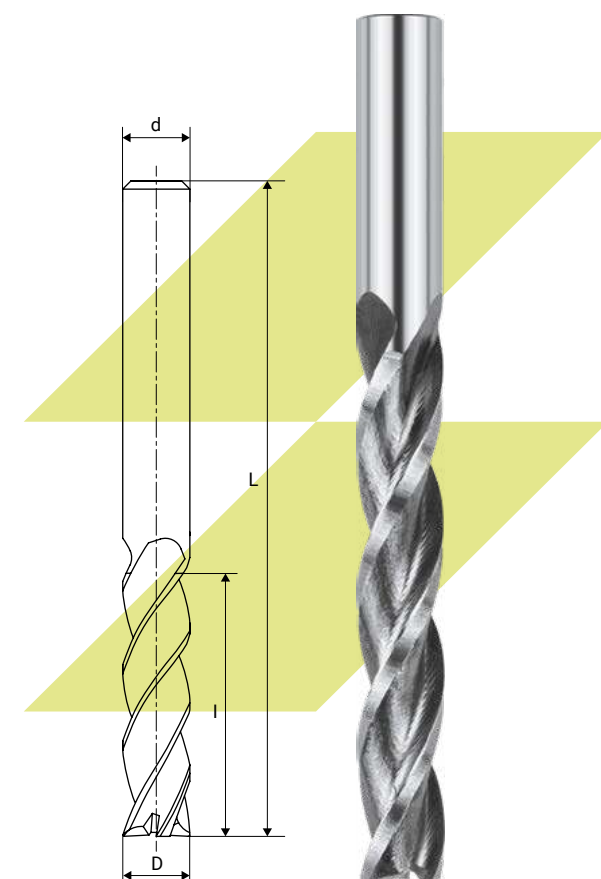

Фрезы концевые с цилиндрическим хвостовиком. Длинная серия

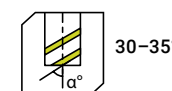
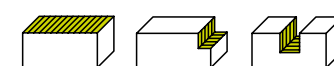

Артикул		D, мм	d, мм	l, мм	L, мм	Z, шт
1172634	●	4,0	4,0	19,0	51,0	4
1378632	●	4,0	6,0	19,0	51,0	4
1172651	●	5,0	5,0	24,0	58,0	4
1378637	●	5,0	6,0	24,0	58,0	4
1172665	●	6,0	6,0	24,0	68,0	4
1172690	●	8,0	8,0	38,0	82,0	4
1172717	●	10,0	10,0	45,0	95,0	4
1185085	●	11,0	10,0	45,0	102,0	6
1379123	●	11,0	12,0	45,0	102,0	6
1172743	●	12,0	12,0	53,0	110,0	5
1185087	●	12,0	12,0	53,0	110,0	6
1172761	●	14,0	14,0	53,0	110,0	5
1185090	●	14,0	14,0	53,0	110,0	6
1379449	●	14,0	12,0	53,0	110,0	6
1172777	●	16,0	16,0	63,0	123,0	5
1172816	●	18,0	18,0	63,0	123,0	6
1379624	●	18,0	16,0	63,0	123,0	6
1172792	●	20,0	20,0	75,0	141,0	5
1172793	●	20,0	20,0	75,0	141,0	6
1424992	●	22,0	22,0	75,0	141,0	6
1424993	●	24,0	24,0	90,0	166,0	6
1424994	●	25,0	25,0	90,0	166,0	6
1424995	●	28,0	28,0	90,0	166,0	6

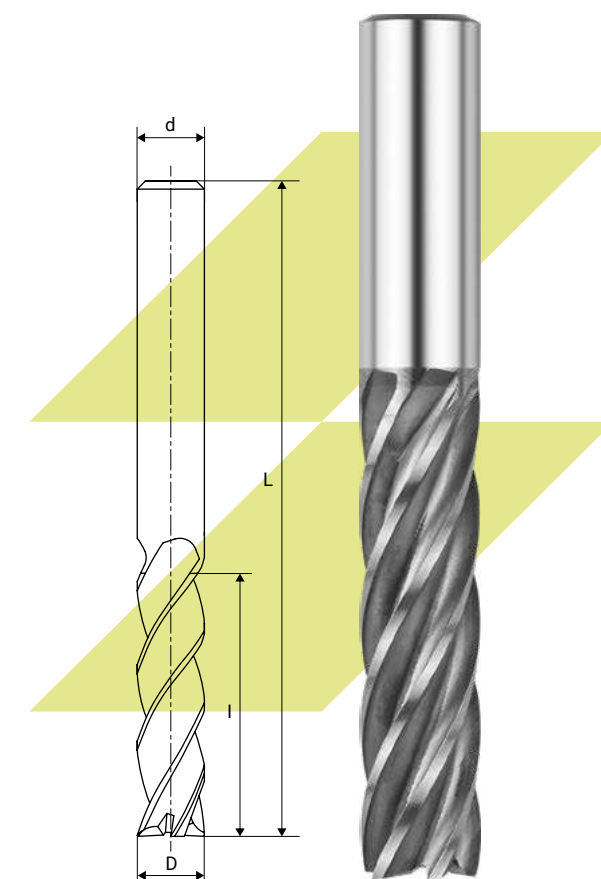

Фрезерование

Фрезерование

Фрезы концевые с цилиндрическим хвостовиком. Длинная серия

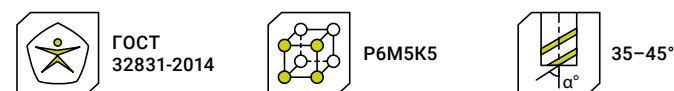
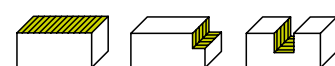

Артикул		D, мм	d, мм	l, мм	L, мм	Z, шт
1256926		3,0	6,0	12,0	44,0	3
1256929		4,0	6,0	19,0	51,0	3
1256932		5,0	6,0	24,0	58,0	3
1256935		6,0	6,0	24,0	68,0	3
1256938		8,0	8,0	38,0	82,0	3
1256941		10,0	10,0	45,0	95,0	3
1256945		12,0	12,0	53,0	110,0	4
1256949		14,0	14,0	53,0	110,0	4
1256953		16,0	16,0	63,0	123,0	4
1256957		18,0	16,0	63,0	123,0	4
1256961		20,0	20,0	75,0	141,0	4

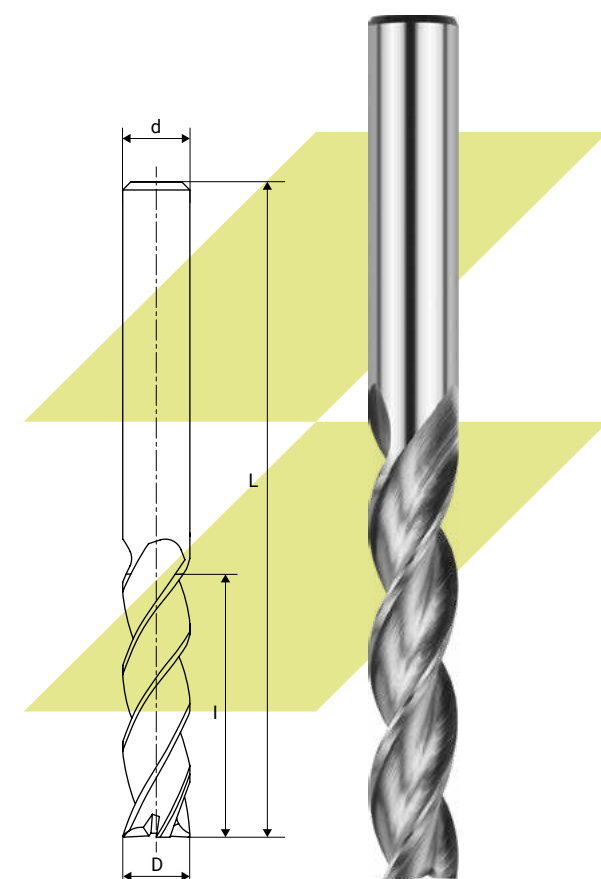

Фрезы концевые с цилиндрическим хвостовиком. Длинная серия

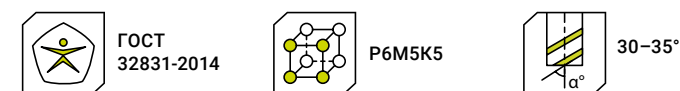
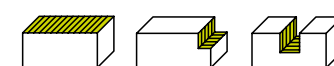

Артикул		D, мм	d, мм	l, мм	L, мм	Z, шт
1256927		3,0	6,0	12,0	44,0	4
1256930		4,0	6,0	19,0	51,0	4
1256933		5,0	6,0	24,0	58,0	4
1256936		6,0	6,0	24,0	68,0	4
1256939		8,0	8,0	38,0	82,0	4
1256942		10,0	10,0	45,0	95,0	4
1256946		12,0	12,0	53,0	110,0	5
1256950		14,0	12,0	53,0	110,0	5
1256954		16,0	16,0	63,0	123,0	5
1256958		18,0	16,0	63,0	123,0	6
1256962		20,0	20,0	75,0	141,0	6

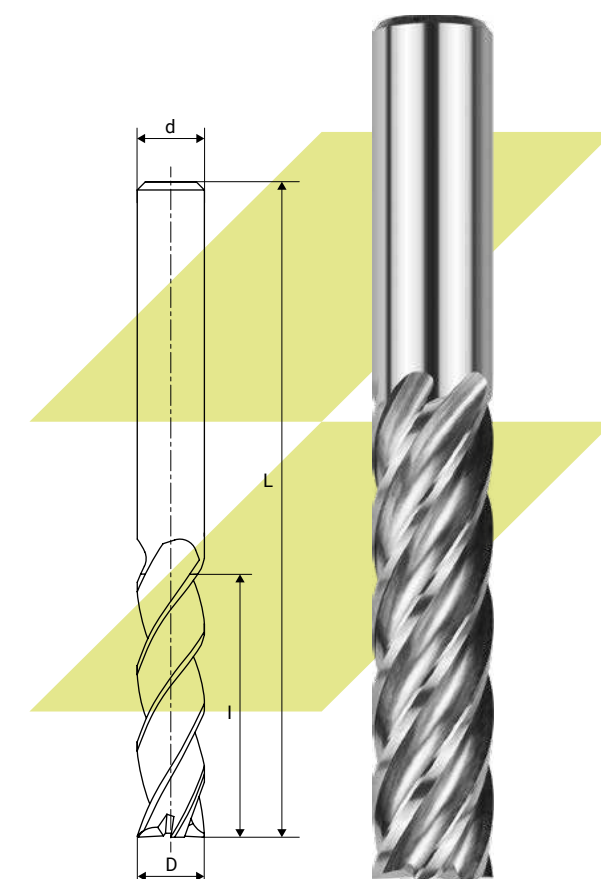

Фрезы концевые с цилиндрическим хвостовиком. Сверхдлинная серия

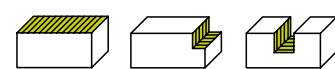

Артикул		D, мм	d, мм	l, мм	L, мм	Z, шт	Тип
1337467	●	6,0	6,0	56,0	100,0	3	2
1337468	●	6,0	6,0	56,0	100,0	4	1
1337439	●	6,0	6,0	56,0	100,0	5	
1337440	●	8,0	8,0	63,0	106,0	3	2
1337441	●	8,0	8,0	63,0	106,0	4	1
1337442	●	8,0	8,0	63,0	106,0	5	
1337443	●	10,0	10,0	70,0	112,0	3	2
1337444	●	10,0	10,0	70,0	112,0	4	1
1337445	●	10,0	10,0	70,0	112,0	5	
1425294	●	10,0	10,0	75,0	125,0	3	2
1425295	●	10,0	10,0	75,0	125,0	4	1
1425296	●	10,0	10,0	75,0	125,0	5	
1337446	●	12,0	12,0	75,0	125,0	3	
1337447	●	12,0	12,0	75,0	125,0	4	2
1337448	●	12,0	12,0	75,0	125,0	5	1

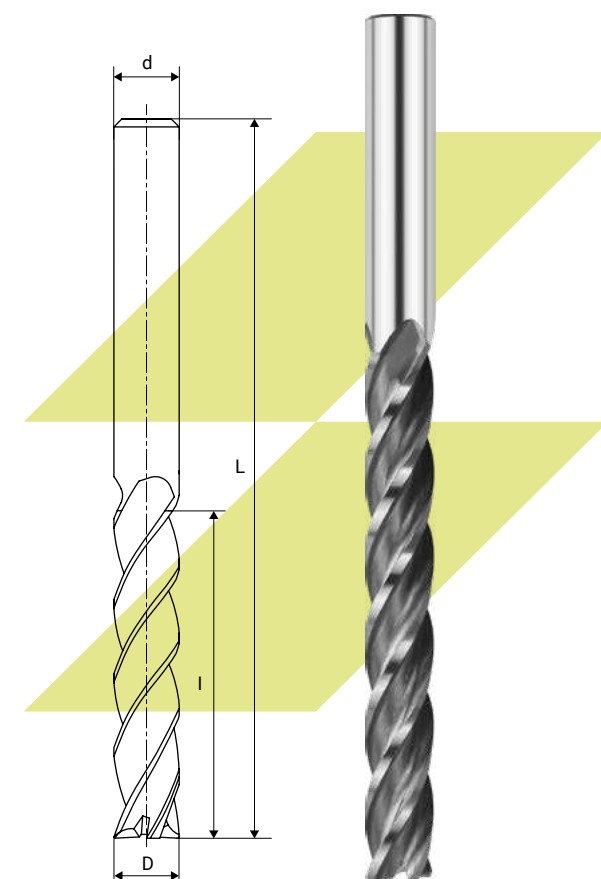

Фрезы концевые двусторонние. Средняя серия

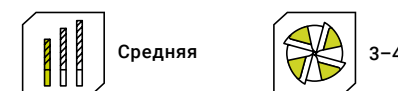
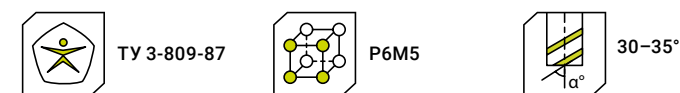
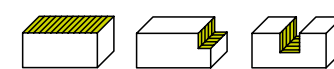

Артикул		D, мм	d, мм	l, мм	L, мм	Z, шт	Тип
1172622	●	3,0	3,0	10,0	50,0	3	2
1175048	●	3,0	3,0	10,0	45,0	4	1
1172631	●	4,0	4,0	15,0	60,0	3	2
1175049	●	4,0	4,0	15,0	55,0	4	1
1178675	●	5,0	5,0	14,0	65,0	4	1
1226805	●	5,0	5,0	17,0	58,0	3	2
1172647	●	5,0	5,0	20,0	80,0	4	1
1172659	●	6,0	6,0	15,0	65,0	3	2
1175050	●	6,0	6,0	18,0	65,0	4	1
1178557	●	8,0	8,0	20,0	80,0	4	1
1175051	●	10,0	10,0	20,0	80,0	4	1
1479664	●	10,0	10,0	25,0	100,0	3	2
1175052	●	12,0	12,0	20,0	80,0	4	2

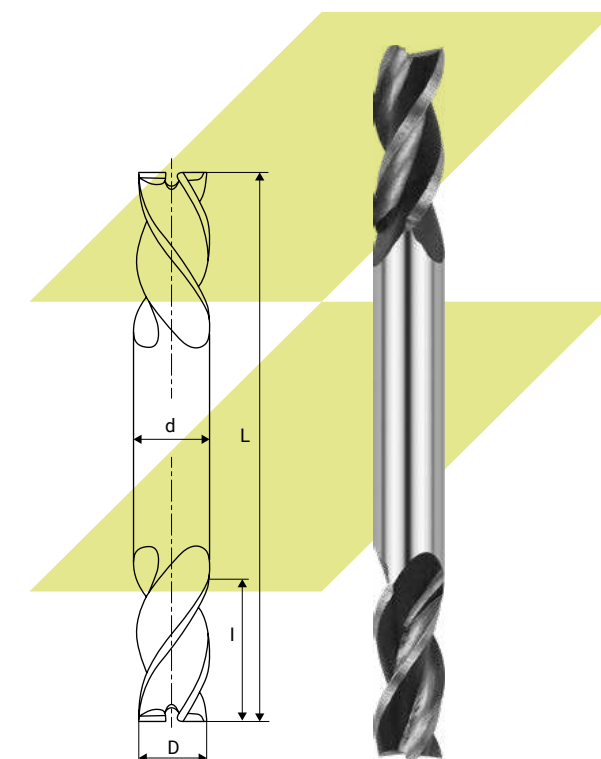

Фрезы концевые с цилиндрическим хвостовиком твердосплавные. Средняя серия

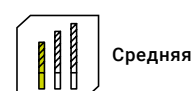
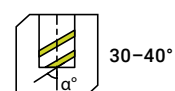
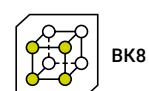
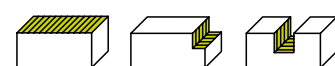

Артикул		D, мм	d, мм	l, мм	L, мм	Z, шт
1330811	●	2,0	2,0	4,0	50,0	4
1416422	●	4,0	6,0	5,0	54,0	3
1416424	●	5,0	6,0	6,0	54,0	3
1416425	●	5,0	6,0	13,0	57,0	4
1416426	●	6,0	6,0	7,0	54,0	3
1416427	●	6,0	6,0	13,0	57,0	4
1416428	●	10,0	10,0	11,0	66,0	3
1416429	●	10,0	10,0	22,0	72,0	4
1416430	●	14,0	14,0	14,0	75,0	3
1416431	●	14,0	14,0	26,0	83,0	4
1416432	●	16,0	16,0	16,0	82,0	3
1416433	●	16,0	16,0	32,0	92,0	4
1416434	●	18,0	18,0	18,0	84,0	3
1416435	●	18,0	18,0	32,0	92,0	4
1416436	●	20,0	20,0	20,0	92,0	3
1416437	●	20,0	20,0	38,0	104,0	4

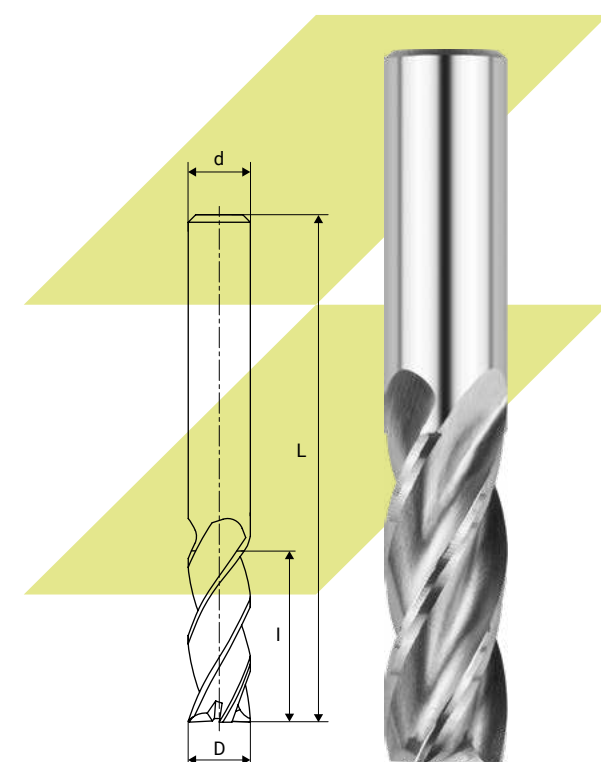

Фрезы концевые с цилиндрическим хвостовиком твердосплавные. Средняя серия

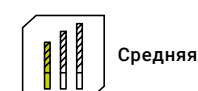
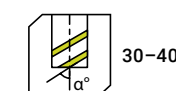
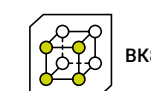
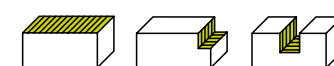

Артикул		Обозначение по ГОСТ	D, мм	d, мм	l, мм	L, мм	Z, шт
1284556	●	2220-0171	3,0	3,0	8,0	28,0	3
1284557	●	2220-0173	3,0	3,0	8,0	28,0	4
1284558	●	2220-0179	4,0	4,0	10,0	32,0	3
1284559	●	2220-0181	4,0	4,0	10,0	32,0	4
1284560	●	2220-0187	5,0	5,0	12,0	36,0	3
1284561	●	2220-0189	5,0	5,0	12,0	36,0	4
1284562	●	2220-0197	6,0	6,0	16,0	40,0	3
1284563	●	2220-0199	6,0	6,0	16,0	40,0	4
1284564	●	2220-0201	6,0	6,0	16,0	40,0	5
1284565	●	2220-0209	7,0	7,0	16,0	40,0	3
1284566	●	2220-0211	7,0	7,0	16,0	40,0	4
1284567	●	2220-0213	7,0	7,0	16,0	40,0	5
1284568	●	2220-0221	8,0	8,0	20,0	45,0	3
1284569	●	2220-0223	8,0	8,0	20,0	45,0	4
1284570	●	2220-0225	8,0	8,0	20,0	45,0	5
1284571	●	2220-0233	9,0	9,0	20,0	45,0	3
1284572	●	2220-0235	9,0	9,0	20,0	45,0	4
1284573	●	2220-0237	9,0	9,0	20,0	45,0	5
1284574	●	2220-0245	10,0	10,0	20,0	50,0	3
1284575	●	2220-0247	10,0	10,0	20,0	50,0	4
1284576	●	2220-0249	10,0	10,0	20,0	50,0	5
1284577	●	2220-0257	11,0	11,0	20,0	50,0	3
1284578	●	2220-0259	11,0	11,0	20,0	50,0	4
1284579	●	2220-0261	11,0	11,0	20,0	50,0	5
1284580	●	2220-0269	12,0	12,0	25,0	60,0	3
1284581	●	2220-0271	12,0	12,0	25,0	60,0	4
1284582	●	2220-0273	12,0	12,0	25,0	60,0	5

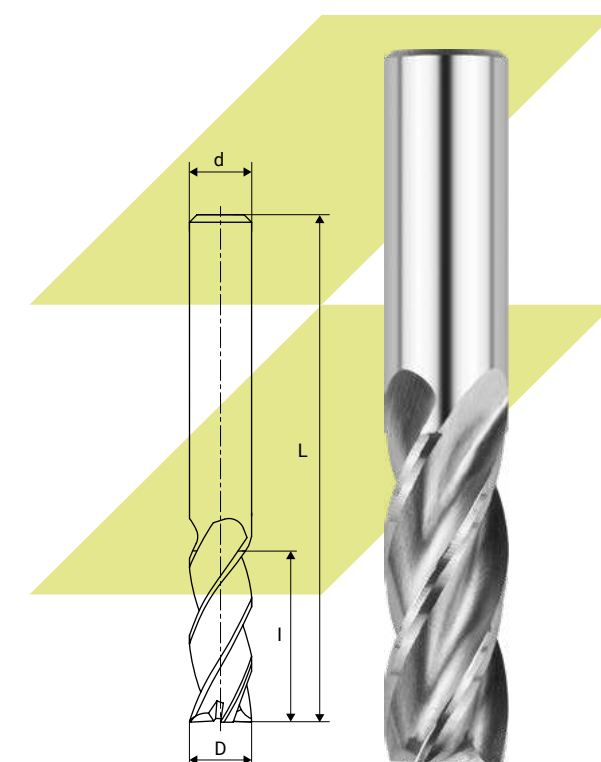

Фрезы концевые с цилиндрическим хвостовиком твердосплавные. Средняя серия

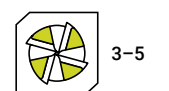
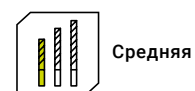
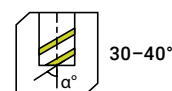
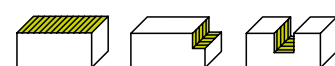

Артикул	Обозначение по ГОСТ	D, мм	d, мм	l, мм	L, мм	Z, шт
1276666	2220-0197	6,0	6,0	16,0	40,0	3
1276667	2220-0199	6,0	6,0	16,0	40,0	4
1276668	2220-0221	8,0	8,0	20,0	45,0	3
1276669	2220-0223	8,0	8,0	20,0	45,0	4
1276670	2220-0245	10,0	10,0	20,0	50,0	3
1276671	2220-0249	10,0	10,0	20,0	50,0	5
1276672	2220-0269	12,0	12,0	25,0	60,0	3
1276673	2220-0273	12,0	12,0	25,0	60,0	5

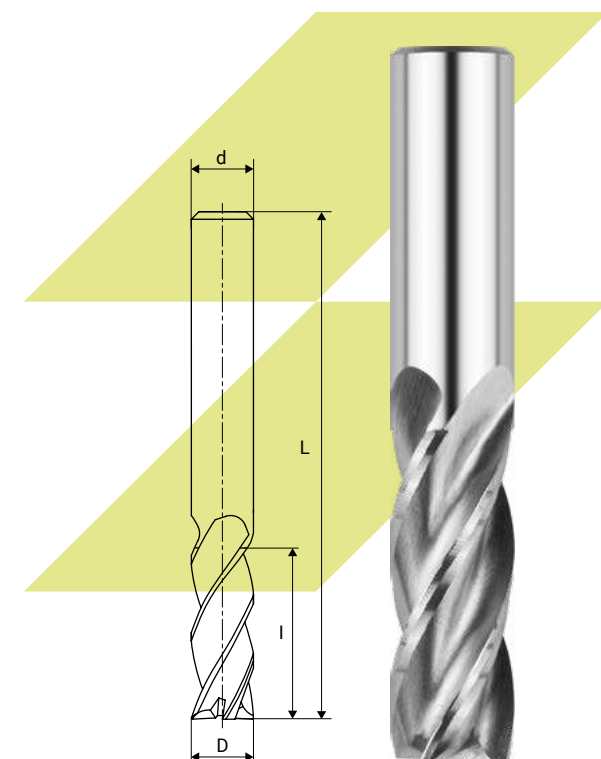

Фрезы концевые с цилиндрическим хвостовиком твердосплавные. Средняя серия

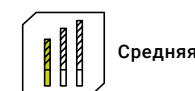
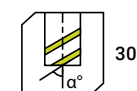
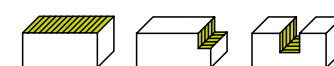

Артикул	D, мм	d, мм	l, мм	L, мм	Z, шт
1175731	3,0	3,0	8,0	50,0	4
1263018	4,0	4,0	11,0	50,0	3
1175732	4,0	4,0	11,0	50,0	4
1263019	5,0	5,0	13,0	50,0	3
1175733	5,0	5,0	13,0	50,0	4
1175734	6,0	6,0	15,0	50,0	4
1185660	7,0	7,0	20,0	60,0	4
1175735	8,0	8,0	20,0	60,0	4
1185661	9,0	9,0	20,0	60,0	4
1263022	10,0	10,0	25,0	75,0	3
1185662	11,0	11,0	25,0	75,0	4
1263023	12,0	12,0	30,0	75,0	3
1175737	12,0	12,0	30,0	75,0	4
1263024	12,0	12,0	30,0	75,0	5
1175738	14,0	14,0	35,0	100,0	4
1175739	16,0	16,0	40,0	100,0	4
1236376	22,0	22,0	45,0	100,0	4
1236377	25,0	25,0	45,0	100,0	4

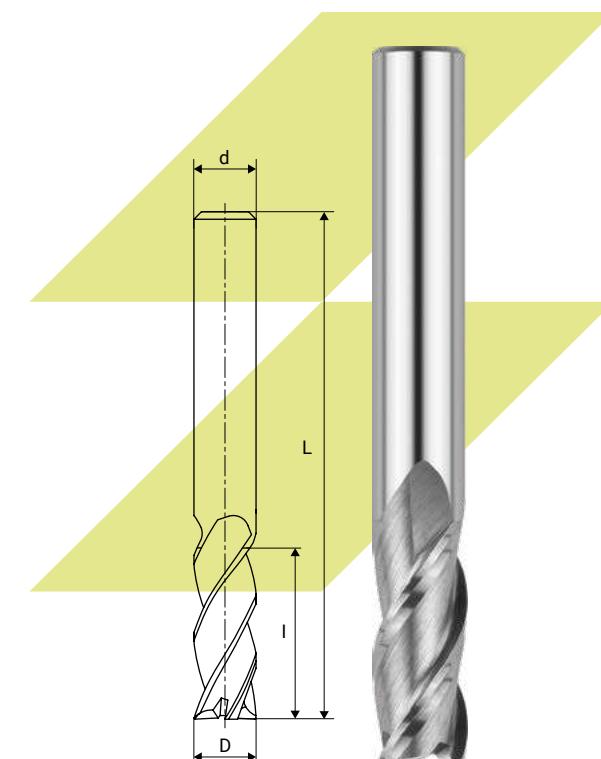

Фрезы концевые с цилиндрическим хвостовиком твердосплавные. Средняя серия

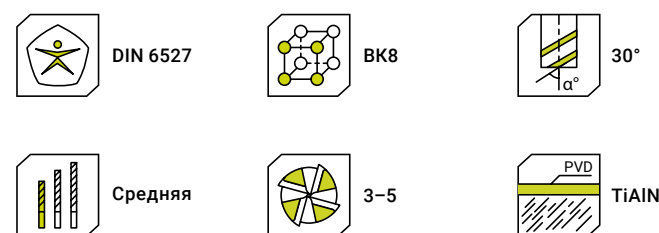
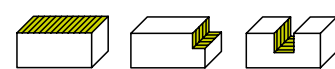

Артикул		D, мм	d, мм	l, мм	L, мм	Z, шт
1441608	●	3,0	3,0	8,0	50,0	3
1441610	●	4,0	4,0	11,0	50,0	3
1441612	●	5,0	5,0	13,0	50,0	3
1441613	●	5,0	5,0	13,0	50,0	4
1441614	●	6,0	6,0	15,0	50,0	3
1441617	●	8,0	8,0	20,0	60,0	3
1441620	●	10,0	10,0	25,0	75,0	3
1441621	●	10,0	10,0	25,0	75,0	4
1441622	●	11,0	11,0	25,0	75,0	4
1441623	●	12,0	12,0	30,0	75,0	3
1441625	●	12,0	12,0	30,0	75,0	5

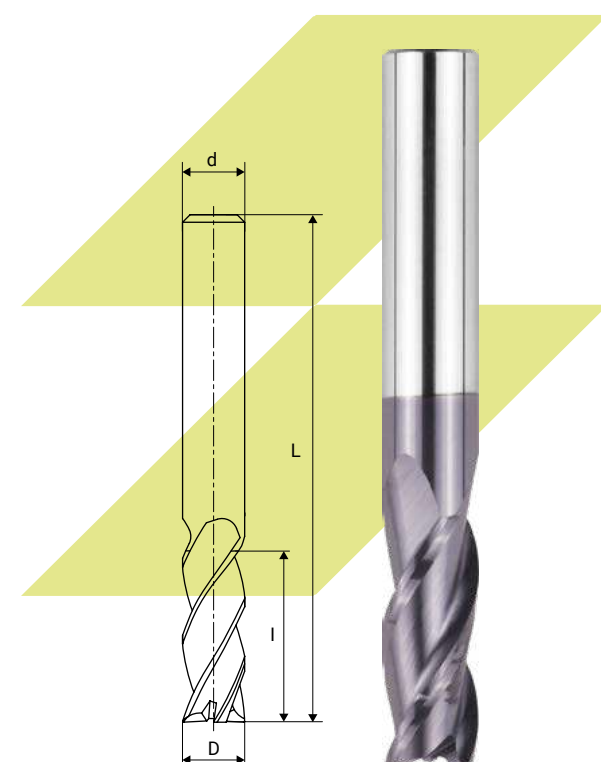

Фрезы концевые с цилиндрическим хвостовиком твердосплавные для чистовой и получистовой обработки алюминия

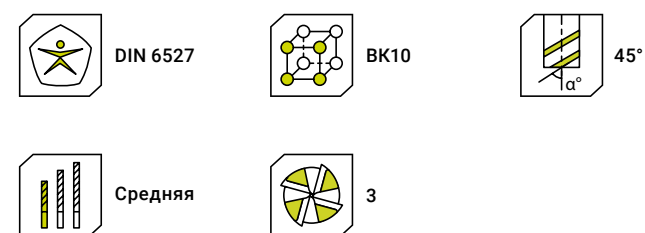
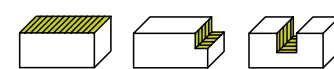

Артикул		D, мм	d, мм	l, мм	L, мм
1851113	●	1,0	4,0	3,0	50,0
1851114	●	1,5	4,0	5,0	50,0
1851115	●	2,0	4,0	6,0	50,0
1851116	●	2,5	4,0	8,0	50,0
1846619	●	3,0	3,0	9,0	50,0
1851121	●	3,0	3,0	15,0	75,0
1848227	●	4,0	4,0	12,0	50,0
1851122	●	4,0	4,0	20,0	75,0
1851117	●	5,0	6,0	15,0	50,0
1851123	●	5,0	5,0	20,0	75,0
1848226	●	6,0	6,0	18,0	50,0
1851124	●	6,0	6,0	30,0	75,0
1846620	●	8,0	8,0	24,0	60,0
1851125	●	8,0	8,0	35,0	75,0
1846621	●	10,0	10,0	30,0	75,0
1851126	●	10,0	10,0	40,0	100,0
1851118	●	12,0	12,0	36,0	75,0
1851127	●	12,0	12,0	45,0	100,0
1851119	●	16,0	16,0	45,0	100,0
1851128	●	16,0	16,0	60,0	150,0
1851120	●	20,0	20,0	45,0	100,0
1851129	●	20,0	20,0	70,0	150,0

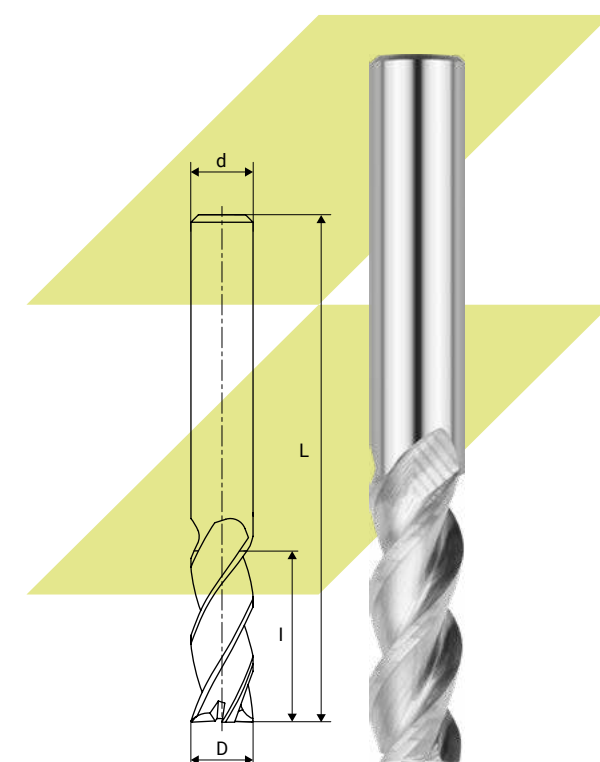

Фрезы концевые с цилиндрическим хвостовиком твердосплавные. Средняя серия

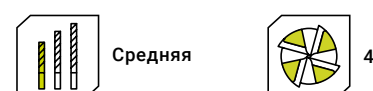
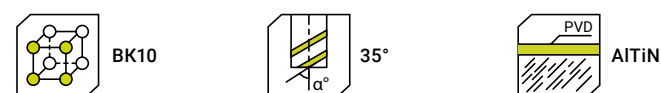
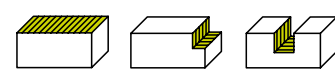

Артикул	D, мм	d, мм	l, мм	L, мм
1805801	1,0	4,0	3,0	50,0
1805802	1,5	4,0	4,0	50,0
1805803	2,0	4,0	6,0	50,0
1805804	2,5	4,0	7,0	50,0
1805805	2,5	6,0	7,0	50,0
1805806	3,0	3,0	8,0	50,0
1805807	3,0	4,0	8,0	50,0
1805808	3,0	6,0	8,0	50,0
1805809	3,5	4,0	10,0	50,0
1805810	3,5	6,0	10,0	50,0
1805811	4,0	4,0	10,0	50,0
1805812	4,0	6,0	10,0	50,0
1805813	4,5	6,0	12,0	50,0
1805814	5,0	5,0	13,0	50,0
1805815	5,0	6,0	13,0	50,0
1805816	6,0	6,0	15,0	50,0
1805817	7,0	8,0	18,0	60,0
1805818	8,0	8,0	20,0	60,0
1851134	8,0	8,0	25,0	75,0
1805819	9,0	10,0	23,0	75,0
1805820	10,0	10,0	25,0	75,0
1805821	11,0	12,0	28,0	75,0
1805822	12,0	12,0	30,0	75,0
1805823	14,0	14,0	35,0	80,0
1805825	16,0	16,0	45,0	100,0
1805826	18,0	18,0	45,0	100,0
1805827	20,0	20,0	45,0	100,0

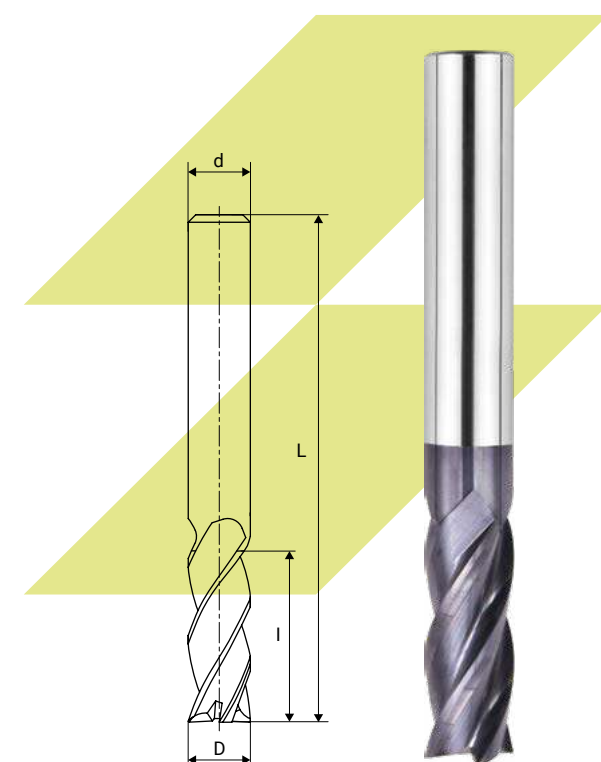

Фрезы концевые с цилиндрическим хвостовиком твердосплавные. Длинная серия

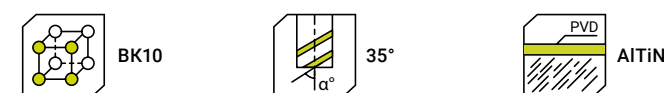
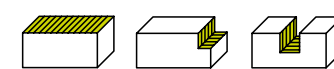

Артикул	D, мм	d, мм	l, мм	L, мм
1851130	3,0	3,0	12,0	75,0
1851131	4,0	4,0	16,0	75,0
1851132	5,0	5,0	20,0	75,0
1851133	6,0	6,0	20,0	75,0
1851135	10,0	10,0	40,0	100,0
1851136	12,0	12,0	45,0	100,0
1805824	14,0	14,0	45,0	100,0
1851137	16,0	16,0	60,0	150,0
1851138	20,0	20,0	70,0	150,0

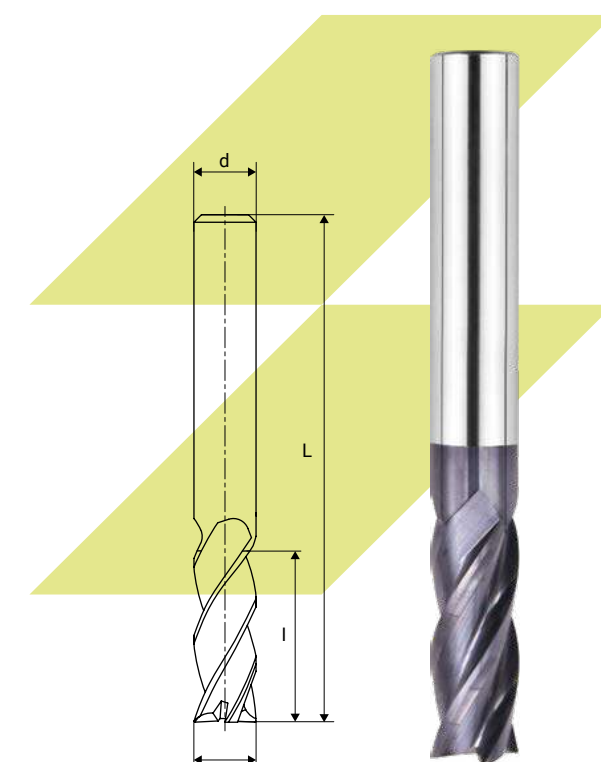

Фрезы концевые с цилиндрическим хвостовиком твердосплавные. Средняя серия

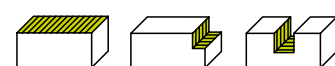

Артикул	D, мм	d, мм	l, мм	L, мм
1874249	1,0	4,0	3,0	50,0
1874250	1,5	4,0	4,0	50,0
1874251	2,0	4,0	6,0	50,0
1874252	3,0	4,0	8,0	50,0
1874253	4,0	4,0	10,0	50,0
1874254	5,0	6,0	13,0	50,0
1874255	6,0	6,0	15,0	50,0
1874256	8,0	8,0	20,0	60,0
1874257	10,0	10,0	25,0	75,0
1874258	12,0	12,0	30,0	75,0
1874259	14,0	14,0	45,0	100,0
1874260	16,0	16,0	45,0	100,0
1874261	18,0	18,0	45,0	100,0
1874262	20,0	20,0	45,0	100,0

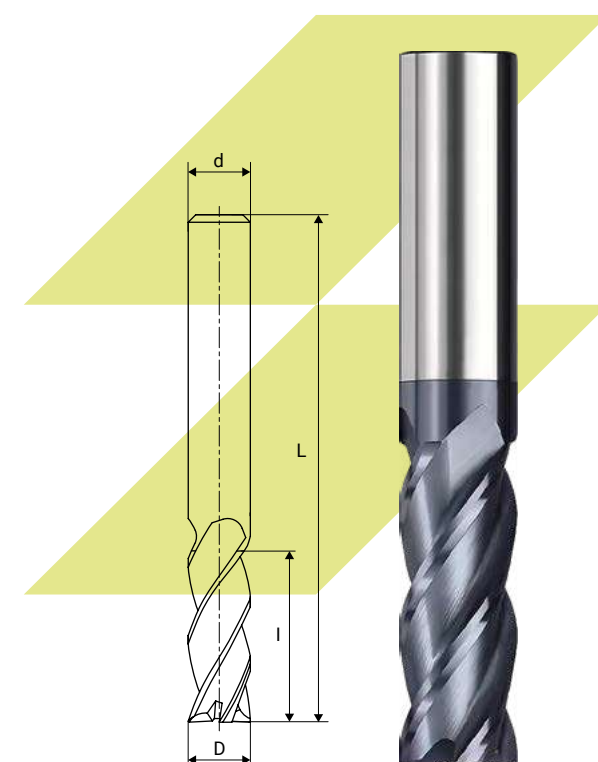

Фрезы концевые с цилиндрическим хвостовиком, оснащенные винтовыми твердосплавными пластинами. Средняя серия

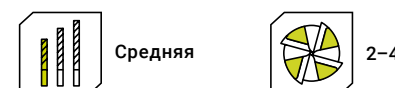
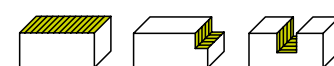

Артикул	Обозначение по ГОСТ	D, мм	d, мм	l, мм	l ₁ , мм	L, мм	Z, шт
1378615	2220-0501	10,0	10,0	14,0	40,0	70,0	2
1378617	2220-0502	12,5	12,5	14,0	45,0	80,0	2
1378619	2220-0503	16,0	16,0	13,0	48,0	90,0	3
1378621	2220-0504	20,0	20,0	12,0	50,0	90,0	4

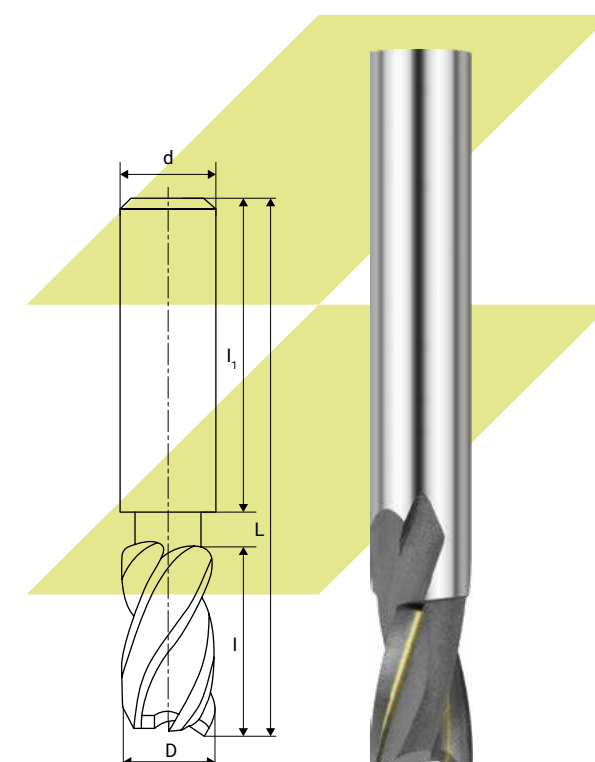

Фрезы концевые с цилиндрическим хвостовиком, оснащенные винтовыми твердосплавными пластинами. Средняя серия

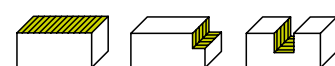

Артикул	Обозначение по ГОСТ	D, мм	d, мм	l, мм	l ₁ , мм	L, мм	Z, шт
1378616	2220-0501	10,0	10,0	14,0	40,0	70,0	2
1378618	2220-0502	12,5	12,5	14,0	45,0	80,0	2
1378620	2220-0503	16,0	16,0	13,0	48,0	90,0	3
1378622	2220-0504	20,0	20,0	12,0	50,0	90,0	4

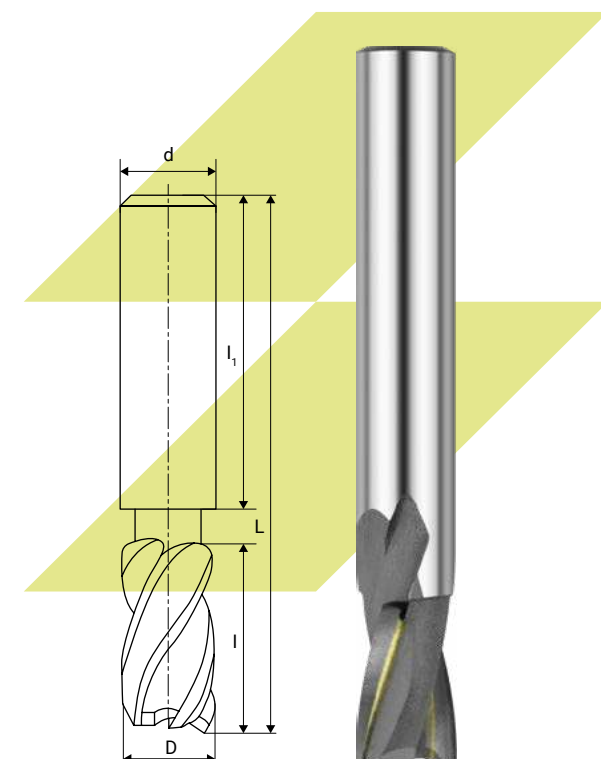

Фрезы концевые с коническим хвостовиком из быстрорежущей стали. Средняя серия

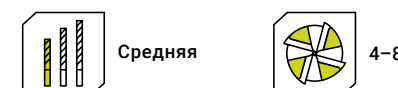
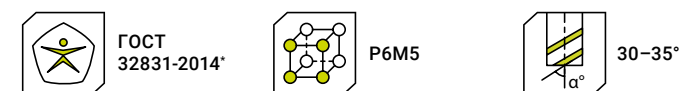
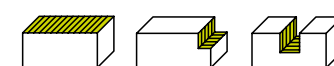

Артикул	Обозначение по ГОСТ	D, мм	l, мм	L, мм	Z, шт	КМ
1171724	2223-0112	10,0	22,0	92,0	4	КМ1
1269461	2223-0129	12,0	26,0	96,0	4	КМ1
1171737	2223-0165	12,0	26,0	111,0	4	КМ2
1174781	2223-0292	14,0	26,0	96,0	4	КМ1
1171751	2223-0001	14,0	26,0	111,0	4	КМ2
1174782	—	14,0	26,0	96,0	6	КМ1
1533132	—	14,0	26,0	111,0	5	КМ2
1171777	2223-0003	16,0	32,0	117,0	4	КМ2
1178237	—	16,0	32,0	117,0	5	КМ2
1174783	—	16,0	32,0	117,0	6	КМ2
1256872	2223-0005	18,0	32,0	117,0	4	КМ2
1174784	—	18,0	32,0	117,0	6	КМ2
1171839	2223-0296	20,0	38,0	123,0	5	КМ2
1171846	2223-0007	20,0	38,0	140,0	5	КМ3
1174785	—	20,0	38,0	123,0	6	КМ2
1174793	—	20,0	38,0	140,0	6	КМ3
1220052	2223-0138	22,0	38,0	123,0	5	КМ2
1171888	2223-0009	22,0	38,0	140,0	5	КМ3
1174797	—	22,0	38,0	123,0	6	КМ2
1174794	—	22,0	38,0	140,0	6	КМ3
1178243	—	24,0	45,0	147,0	5	КМ3
1171916	2223-0011	25,0	45,0	147,0	5	КМ3
1174797	—	25,0	45,0	147,0	6	КМ3
1264133	—	26,0	45,0	147,0	5	КМ3
1264134	—	26,0	45,0	147,0	6	КМ3
1171953	2223-0305	28,0	45,0	147,0	5	КМ3
1174800	—	28,0	45,0	147,0	6	КМ3
1171980	—	30,0	53,0	155,0	6	КМ3
1171988	—	30,0	53,0	178,0	6	КМ4
1174802	—	30,0	53,0	155,0	5	КМ3
1174803	—	30,0	53,0	178,0	5	КМ4
1172028	2223-0147	32,0	53,0	155,0	6	КМ3
1172036	2223-0015	32,0	53,0	178,0	6	КМ4

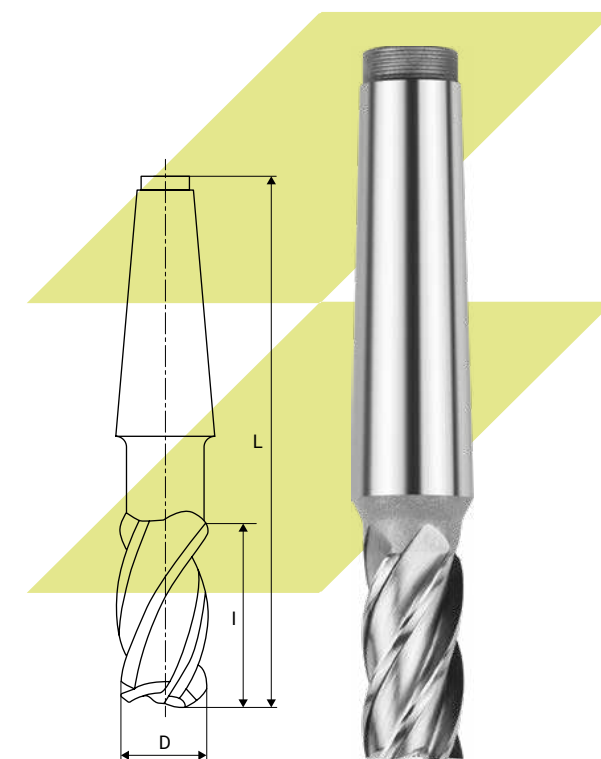

Артикул	Обозначение по ГОСТ	D, мм	I, мм	L, мм	Z, шт	КМ
1178246	—	32,0	53,0	178,0	5	КМ4
1424966	—	34,0	53,0	178,0	6	КМ4
1256875	—	35,0	53,0	178,0	6	КМ4
1335583	2223-0156	36,0	53,0	155,0	6	КМ3
1172097	2223-0017	36,0	53,0	178,0	6	КМ4
1264135	—	36,0	53,0	178,0	5	КМ4
1172115	—	38,0	53,0	178,0	6	КМ4
1172122	2223-0019	40,0	63,0	188,0	6	КМ4
1172129	2223-0309	40,0	63,0	221,0	6	КМ5
1178249	—	40,0	63,0	188,0	5	КМ4
1172896	—	42,0	63,0	188,0	6	КМ4

Артикул	Обозначение по ГОСТ	D, мм	I, мм	L, мм	Z, шт	КМ
1178250	—	45,0	63,0	188,0	5	КМ4
1172179	2223-0021	45,0	63,0	188,0	6	КМ4
1172184	2223-0023	45,0	63,0	221,0	6	КМ5
1240469	—	48,0	75,0	200,0	6	КМ4
1172221	2223-0025	50,0	75,0	200,0	6	КМ4
1172228	2223-0027	50,0	75,0	233,0	6	КМ5
1172897	—	55,0	75,0	233,0	8	КМ5
1172272	2223-0785	56,0	75,0	200,0	8	КМ4
1172274	2223-0787	56,0	75,0	233,0	8	КМ5
1174806	—	60,0	90,0	248,0	8	КМ5
1172299	2223-0791	63,0	90,0	248,0	8	КМ5

Фрезы концевые с коническим хвостовиком из быстрорежущей стали. Средняя серия

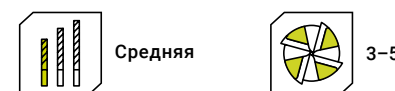
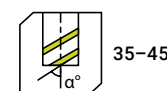
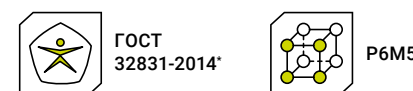
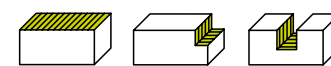

Артикул	Обозначение по ГОСТ	D, мм	I, мм	L, мм	Z, шт	КМ
1171722	2223-0116	10,0	22,0	92,0	3	КМ1
1269460	2223-0134	12,0	26,0	96,0	3	КМ1
1171735	2223-0169	12,0	26,0	111,0	3	КМ2
1256871	2223-0314	14,0	26,0	69,0	3	КМ1
1171749	2223-0061	14,0	26,0	111,0	3	КМ2
1171774	2223-0083	16,0	32,0	117,0	3	КМ2
1256873	2223-0085	18,0	32,0	117,0	3	КМ2
1171835	2223-0318	20,0	38,0	123,0	3	КМ2
1171837	—	20,0	38,0	123,0	4	КМ2
1172471	—	20,0	38,0	140,0	4	КМ3
1171841	2223-0087	20,0	38,0	140,0	3	КМ3
1256885	2223-0143	22,0	38,0	123,0	3	КМ2
1174786	—	22,0	38,0	123,0	4	КМ2
1171887	—	22,0	38,0	140,0	4	КМ3
1171885	2223-0089	22,0	38,0	140,0	3	КМ3
1178241	—	24,0	45,0	147,0	3	КМ3
1178242	—	24,0	45,0	147,0	4	КМ3
1171913	2223-0091	25,0	45,0	147,0	3	КМ3
1174796	—	25,0	45,0	147,0	4	КМ3
1264132	—	26,0	45,0	147,0	4	КМ3
1171950	2223-0327	28,0	45,0	147,0	3	КМ3
1171952	—	28,0	45,0	147,0	4	КМ3
1171978	—	30,0	53,0	155,0	4	КМ3
1171984	—	30,0	53,0	178,0	4	КМ4
1172026	2223-0152	32,0	53,0	155,0	4	КМ3
1172031	2223-0095	32,0	53,0	178,0	4	КМ4
1178245	—	32,0	53,0	178,0	3	КМ4
1424965	—	34,0	53,0	178,0	4	КМ4
1174804	—	35,0	53,0	178,0	4	КМ4
1335582	2223-0161	36,0	53,0	155,0	4	КМ3
1172094	2223-0097	36,0	53,0	178,0	4	КМ4
1172114	—	38,0	53,0	178,0	4	КМ4
1172118	2223-0099	40,0	63,0	188,0	4	КМ4

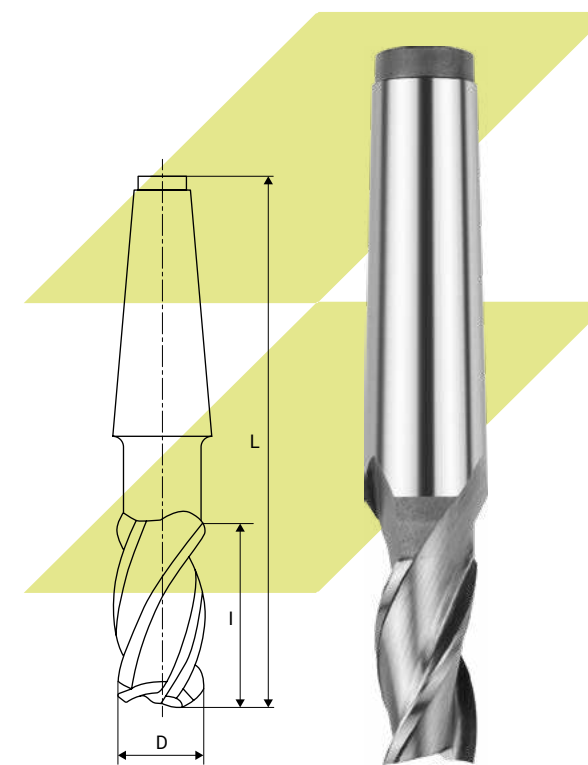

* Взамен действующим стандартам: ГОСТ 53002-2008, ГОСТ 17026-71

Артикул	Обозначение по ГОСТ	D, мм	I, мм	L, мм	Z, шт	КМ
1172126	2223-0332	40,0	63,0	221,0	4	КМ5
1172176	2223-0101	45,0	63,0	188,0	4	КМ4
1172181	2223-0103	45,0	63,0	221,0	4	КМ5
1240468	—	48,0	75,0	200,0	4	КМ4
1172219	2223-0105	50,0	75,0	200,0	4	КМ4
1287012	—	50,0	75,0	200,0	3	КМ4
1172224	2223-0107	50,0	75,0	233,0	4	КМ5
1172271	2223-0863	56,0	75,0	200,0	5	КМ4
1172273	2223-0865	56,0	75,0	233,0	5	КМ5
1174805	—	60,0	90,0	248,0	5	КМ5
1172298	2223-0867	63,0	90,0	248,0	5	КМ5

Фрезы концевые с коническим хвостовиком из быстрорежущей стали. Средняя серия

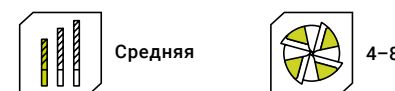
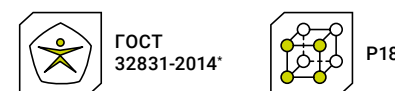
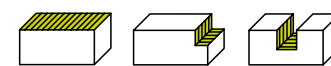

Артикул	Обозначение по ГОСТ	D, мм	I, мм	L, мм	Z, шт	КМ
1323385	2223-0165	12,0	26,0	111,0	4	КМ2
1323389	2223-0001	14,0	26,0	111,0	4	КМ2
1323392	2223-0003	16,0	32,0	117,0	4	КМ2
1323397	2223-0005	18,0	32,0	117,0	4	КМ2
1323398	—	18,0	32,0	117,0	6	КМ2
1323404	2223-0296	20,0	38,0	123,0	5	КМ2
1323405	—	20,0	38,0	123,0	6	КМ2
1323409	—	20,0	38,0	140,0	6	КМ3
1323408	2223-0007	20,0	38,0	140,0	5	КМ3
1323415	2223-0138	22,0	38,0	123,0	5	КМ2
1323416	—	22,0	38,0	123,0	6	КМ2
1323419	2223-0009	22,0	38,0	140,0	5	КМ3
1323420	—	22,0	38,0	140,0	6	КМ3
1323425	2223-0011	25,0	45,0	147,0	5	КМ3
1323426	—	25,0	45,0	147,0	6	КМ3
1323432	2223-0305	28,0	45,0	147,0	5	КМ3
1323433	—	28,0	45,0	147,0	6	КМ3
1323438	—	30,0	53,0	155,0	5	КМ3
1323439	—	30,0	53,0	155,0	6	КМ3
1323441	—	30,0	53,0	178,0	5	КМ4
1323442	—	30,0	53,0	178,0	6	КМ4
1323446	2223-0147	32,0	53,0	155,0	6	КМ3
1323449	—	32,0	53,0	178,0	5	КМ4
1323450	2223-0015	32,0	53,0	178,0	6	КМ4
1323457	—	35,0	53,0	178,0	6	КМ4
1323459	2223-0017	36,0	53,0	178,0	6	КМ4
1323462	2223-0019	40,0	63,0	188,0	6	КМ4
1323463	2223-0309	40,0	63,0	221,0	6	КМ5
1323467	2223-0021	45,0	63,0	188,0	6	КМ4
1323472	2223-0025	50,0	75,0	200,0	6	КМ4
1323475	2223-0785	56,0	75,0	200,0	8	КМ4
1323477	2223-0791	63,0	90,0	248,0	8	КМ5

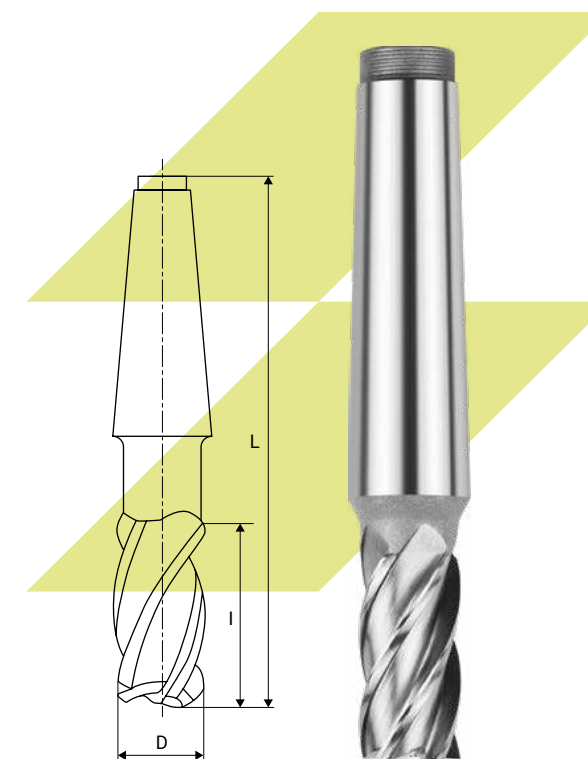

* Взамен действующим стандартам: ГОСТ 53002-2008, ГОСТ 17026-71

Фрезы концевые с коническим хвостовиком из быстрорежущей стали. Средняя серия

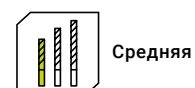
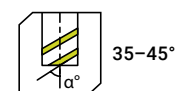
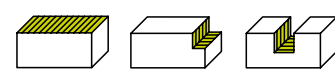

Артикул	Обозначение по ГОСТ	D, мм	I, мм	L, мм	Z, шт	KM
1323384	2223-0169	12,0	26,0	111,0	3	KM2
1323388	2223-0081	14,0	26,0	111,0	3	KM2
1323391	2223-0083	16,0	32,0	117,0	3	KM2
1323396	2223-0085	18,0	32,0	117,0	3	KM2
1323402	2223-0318	20,0	38,0	123,0	3	KM2
1323403	—	20,0	38,0	123,0	4	KM2
1323406	2223-0087	20,0	38,0	140,0	3	KM3
1323407	—	20,0	38,0	140,0	4	KM3
1323413	2223-0143	22,0	38,0	123,0	3	KM2
1323414	—	22,0	38,0	123,0	4	KM2
1323417	2223-0089	22,0	38,0	140,0	3	KM3
1323418	—	22,0	38,0	140,0	4	KM3
1323424	—	25,0	45,0	147,0	4	KM3
1323430	2223-0327	28,0	45,0	147,0	3	KM3
1323431	—	28,0	45,0	147,0	4	KM3
1323437	—	30,0	53,0	155,0	4	KM3
1323440	—	30,0	53,0	178,0	4	KM4
1323445	2223-0152	32,0	53,0	155,0	4	KM3
1323447	—	32,0	53,0	178,0	3	KM4
1323448	2223-0095	32,0	53,0	178,0	4	KM4
1323456	—	35,0	53,0	178,0	4	KM4
1323458	2223-0097	36,0	53,0	178,0	4	KM4
1323461	2223-0099	40,0	63,0	188,0	4	KM4
1323466	2223-0101	45,0	63,0	188,0	4	KM4
1323471	2223-0105	50,0	75,0	200,0	4	KM4

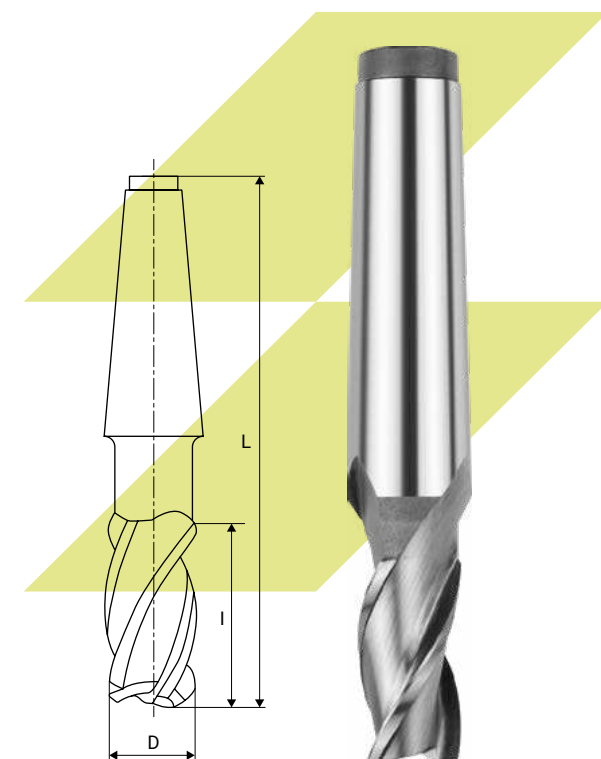

* Взамен действующим стандартам: ГОСТ 53002-2008, ГОСТ 17026-71

Фрезы концевые с коническим хвостовиком из быстрорежущей стали. Средняя серия

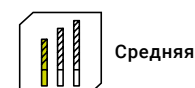
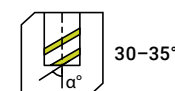
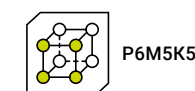
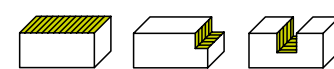

Артикул	D, мм	I, мм	L, мм	Z, шт	KM
1480546	8,0	38,0	123,0	4	KM2
1185689	10,0	22,0	110,0	4	KM2
1480549	10,0	32,0	117,0	4	KM2
1182019	14,0	26,0	111,0	4	KM2
1171754	14,0	26,0	111,0	4	KM2
1343093	16,0	36,0	116,0	3	KM2
1171782	16,0	36,0	116,0	3	KM2
1236505	16,0	50,0	130,0	3	KM2
1185713	20,0	38,0	155,0	6	KM3
1343090	20,0	45,0	145,0	3	KM3
1185714	20,0	45,0	155,0	6	KM3
1260658	22,0	75,0	200,0	3	KM4
1276346	22,0	75,0	200,0	6	KM3
1185720	25,0	53,0	182,0	6	KM4
1185725	30,0	53,0	182,0	6	KM4
1185726	30,0	75,0	205,0	6	KM4
1185729	32,0	53,0	182,0	6	KM4
1172080	35,0	80,0	205,0	6	KM4
1252496	36,0	82,0	225,0	4	KM4
1185736	40,0	75,0	245,0	6	KM5
1172178	45,0	63,0	188,0	4	KM4
1237637	45,0	70,0	230,0	4	KM5
1185741	45,0	75,0	230,0	6	KM5
1417085	50,0	70,0	246,0	6	KM5
1172231	50,0	75,0	233,0	6	KM5
1582778	50,0	90,0	245,0	6	KM5
1253279	60,0	90,0	245,0	6	KM5

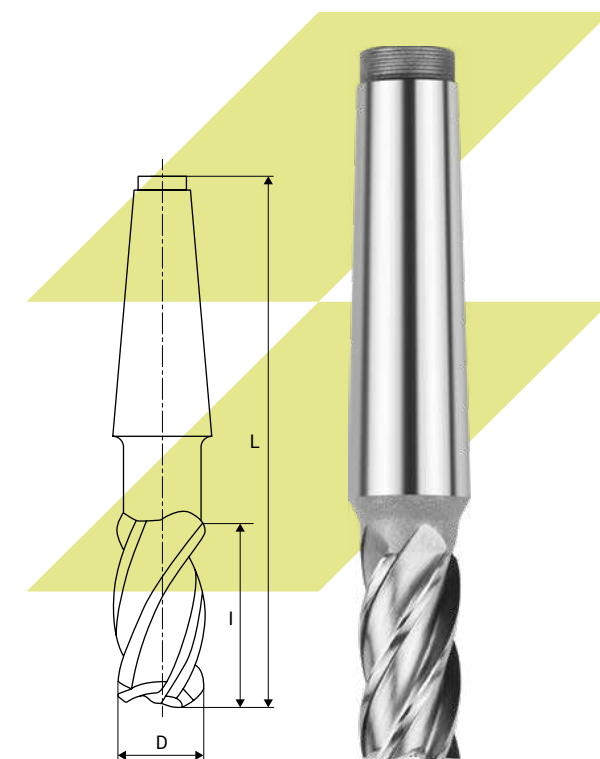

Фрезы концевые с коническим хвостовиком из быстрорежущей стали. Длинная серия

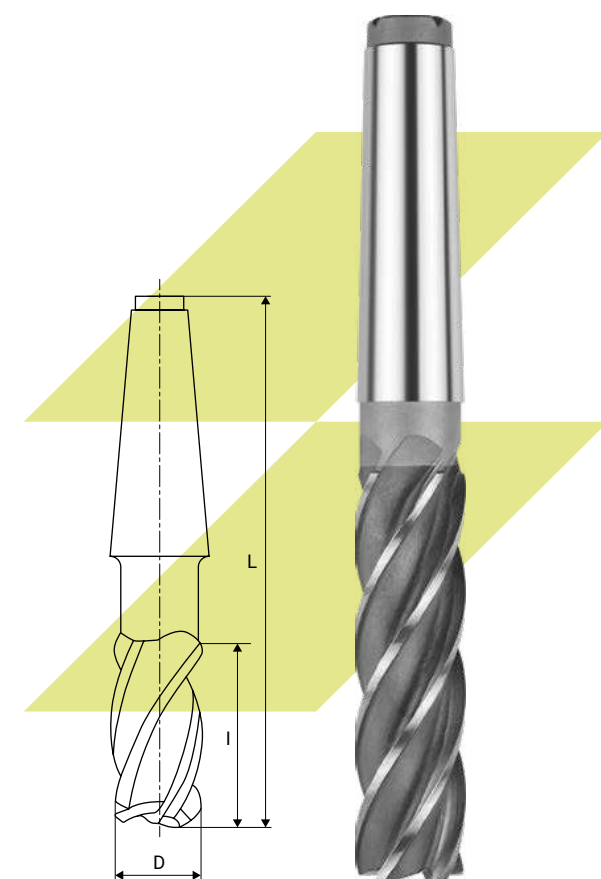
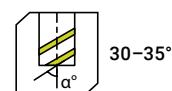
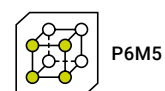
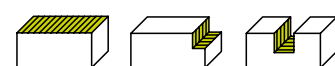

Артикул		D, мм	I, мм	L, мм	Z, шт	КМ
1174789	●	10,0	45,0	115,0	4	КМ1
1252650	●	12,0	53,0	123,0	4	КМ1
1174791	●	12,0	53,0	138,0	4	КМ2
1171761	●	14,0	53,0	138,0	4	КМ2
1178261	●	14,0	100,0	185,0	4	КМ2
1171792	●	16,0	63,0	148,0	4	КМ2
1178238	●	16,0	63,0	148,0	5	КМ2
1171826	●	18,0	63,0	148,0	4	КМ2
1174792	●	18,0	63,0	148,0	6	КМ2
1171860	●	20,0	75,0	160,0	5	КМ2
1171859	●	20,0	75,0	160,0	4	КМ2
1262890	●	20,0	100,0	199,0	6	КМ3
1178264	●	20,0	120,0	215,0	4	КМ3
1178265	●	20,0	150,0	250,0	4	КМ3
1240466	●	20,0	200,0	299,0	4	КМ3
1171902	●	22,0	75,0	177,0	5	КМ3
1174795	●	22,0	75,0	177,0	6	КМ3
1256874	●	24,0	90,0	192,0	5	КМ3
1171940	●	25,0	90,0	192,0	5	КМ3
1174799	●	25,0	90,0	192,0	6	КМ3
1178270	●	25,0	120,0	215,0	6	КМ3
1178271	●	25,0	150,0	250,0	6	КМ3
1171962	●	28,0	90,0	192,0	5	КМ3
1174801	●	28,0	90,0	192,0	6	КМ3
1178272	●	28,0	200,0	305,0	5	КМ3
1240467	●	30,0	106,0	208,0	6	КМ3
1265662	●	30,0	140,0	242,0	6	КМ3
1175985	●	30,0	140,0	350,0	6	КМ3
1172055	●	32,0	106,0	208,0	6	КМ3
1172057	●	32,0	106,0	231,0	6	КМ4
1172057	●	32,0	106,0	231,0	6	КМ4
1172061	●	32,0	140,0	350,0	6	КМ3
1178273	●	32,0	200,0	325,0	6	КМ4

* Взамен действующим стандартам: ГОСТ 53002-2008, ГОСТ 17026-71

Артикул		D, мм	I, мм	L, мм	Z, шт	КМ
1172083	●	35,0	106,0	231,0	6	КМ4
1172108	●	36,0	106,0	231,0	6	КМ4
1178274	●	36,0	200,0	320,0	6	КМ4
1172157	●	40,0	125,0	250,0	6	КМ4
1172163	●	40,0	125,0	283,0	6	КМ5
1178276	●	40,0	200,0	320,0	6	КМ4
1172200	●	45,0	125,0	250,0	6	КМ4
1172204	●	45,0	125,0	283,0	6	КМ5

Артикул		D, мм	I, мм	L, мм	Z, шт	КМ
1172252	●	50,0	150,0	275,0	6	КМ4
1172257	●	50,0	150,0	308,0	6	КМ5
1178278	●	50,0	200,0	320,0	6	КМ4
1172277	●	56,0	150,0	275,0	8	КМ4
1172279	●	56,0	150,0	308,0	8	КМ5
1174901	●	60,0	180,0	338,0	8	КМ5
1172302	●	63,0	180,0	338,0	8	КМ5

Фрезы концевые с коническим хвостовиком из быстрорежущей стали. Длинная серия

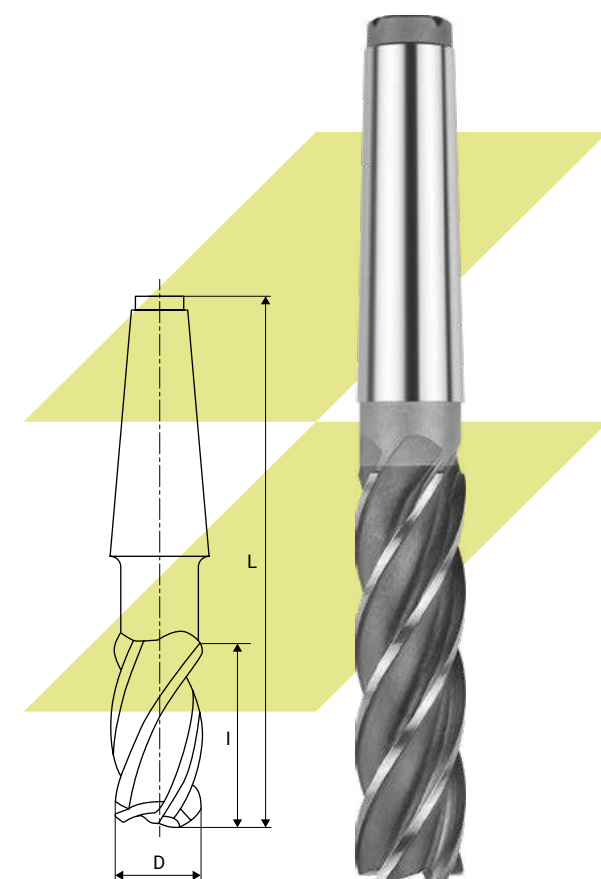
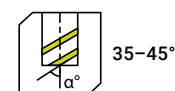
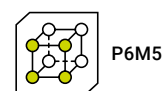
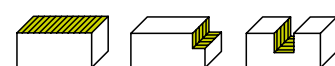

Артикул		D, мм	I, мм	L, мм	Z, шт	КМ
1174788	●	10,0	45,0	115,0	3	КМ1
1252649	●	12,0	53,0	123,0	3	КМ1
1174790	●	12,0	53,0	138,0	3	КМ2
1171757	●	14,0	53,0	138,0	3	КМ2
1171791	●	16,0	63,0	148,0	3	КМ2
1171823	●	18,0	63,0	148,0	3	КМ2
1171858	●	20,0	75,0	160,0	3	КМ2
1171899	●	22,0	75,0	177,0	3	КМ3
1171901	●	22,0	75,0	177,0	4	КМ3
1178266	●	22,0	120,0	215,0	4	КМ3
1178267	●	22,0	150,0	250,0	4	КМ3
1243701	●	24,0	90,0	192,0	4	КМ3
1178244	●	25,0	63,0	188,0	3	КМ4
1174798	●	25,0	90,0	192,0	4	КМ3
1171938	●	25,0	90,0	192,0	3	КМ3
1178268	●	25,0	120,0	215,0	4	КМ3
1178269	●	25,0	150,0	250,0	4	КМ3
1171960	●	28,0	90,0	192,0	3	КМ3
1171961	●	28,0	90,0	192,0	4	КМ3
1172009	●	30,0	106,0	208,0	4	КМ3
1172054	●	32,0	106,0	208,0	4	КМ3
1172056	●	32,0	106,0	231,0	4	КМ4
1178247	●	32,0	106,0	231,0	3	КМ4
1477490	●	36,0	106,0	231,0	4	КМ5
1172156	●	40,0	125,0	250,0	4	КМ4
1172160	●	40,0	125,0	283,0	4	КМ5
1178275	●	40,0	200,0	320,0	4	КМ4
1172198	●	45,0	125,0	250,0	4	КМ4
1172203	●	45,0	125,0	283,0	4	КМ5
1172250	●	50,0	150,0	275,0	4	КМ4
1172255	●	50,0	150,0	308,0	4	КМ5
1178277	●	50,0	200,0	320,0	4	КМ4
1172276	●	56,0	150,0	275,0	5	КМ4

* Взамен действующим стандартам: ГОСТ 53002-2008, ГОСТ 17026-71

Артикул		D, мм	I, мм	L, мм	Z, шт	КМ
1172278	●	56,0	150,0	308,0	5	КМ5
1172301	●	63,0	180,0	338,0	5	КМ5

Фрезы концевые с коническим хвостовиком из быстрорежущей стали. Длинная серия

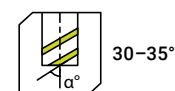
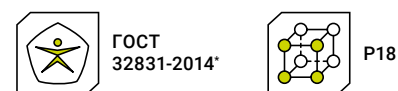
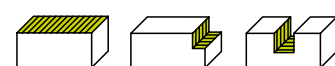

Артикул	D, мм	I, мм	L, мм	Z, шт	KM
1323383	10,0	45,0	127,0	4	KM2
1323387	12,0	53,0	138,0	4	KM2
1323390	14,0	53,0	138,0	4	KM2
1323394	16,0	63,0	148,0	4	KM2
1323395	16,0	63,0	148,0	5	KM2
1323400	18,0	63,0	148,0	4	KM2
1323401	18,0	63,0	148,0	6	KM2
1323412	20,0	75,0	160,0	5	KM2
1323422	22,0	75,0	177,0	5	KM3
1323423	22,0	75,0	177,0	6	KM3
1323428	25,0	90,0	192,0	5	KM3
1323429	25,0	90,0	192,0	6	KM3
1323436	28,0	90,0	192,0	5	KM3
1323444	30,0	106,0	208,0	6	KM3
1323452	32,0	106,0	208,0	6	KM3
1377817	32,0	106,0	231,0	5	KM4
1323455	32,0	106,0	231,0	6	KM4
1323460	36,0	106,0	231,0	6	KM4
1323465	40,0	125,0	250,0	6	KM4
1323470	45,0	125,0	250,0	6	KM4
1323474	50,0	150,0	275,0	6	KM4
1323476	56,0	150,0	275,0	8	KM4
1323478	63,0	180,0	338,0	8	KM5

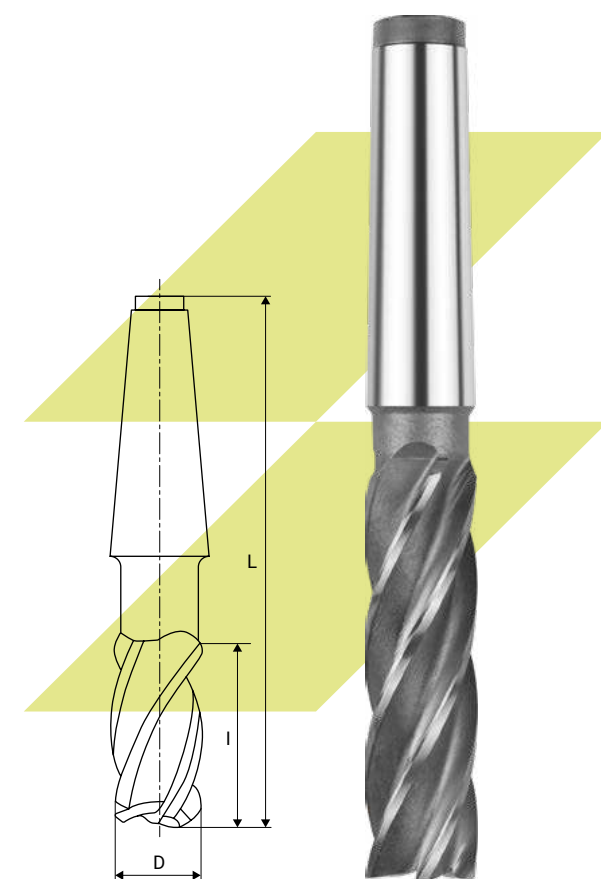

* Взамен действующим стандартам: ГОСТ 53002-2008, ГОСТ 17026-71

Фрезы концевые с коническим хвостовиком из быстрорежущей стали. Длинная серия

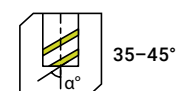
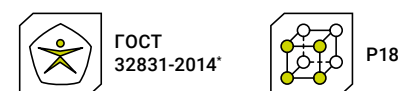
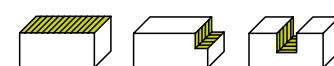

Артикул	D, мм	I, мм	L, мм	Z, шт	KM
1323382	10,0	45,0	127,0	3	KM2
1323386	12,0	53,0	138,0	3	KM2
1171758	14,0	53,0	138,0	3	KM2
1237640	14,0	70,0	152,0	3	KM2
1323393	16,0	63,0	148,0	3	KM2
1323399	18,0	63,0	148,0	3	KM2
1425814	18,0	90,0	170,0	3	KM2
1323410	20,0	75,0	160,0	3	KM2
1323411	20,0	75,0	160,0	4	KM2
1378947	22,0	75,0	177,0	3	KM3
1323421	22,0	75,0	177,0	4	KM3
1323427	25,0	90,0	192,0	4	KM3
1323443	30,0	106,0	208,0	4	KM3
1323451	32,0	106,0	208,0	4	KM3
1323453	32,0	106,0	231,0	3	KM4
1323454	32,0	106,0	231,0	4	KM4
1323464	40,0	125,0	250,0	4	KM4
1323469	45,0	125,0	250,0	4	KM4
1228465	45,0	125,0	280,0	4	KM5
1323473	50,0	150,0	275,0	4	KM4

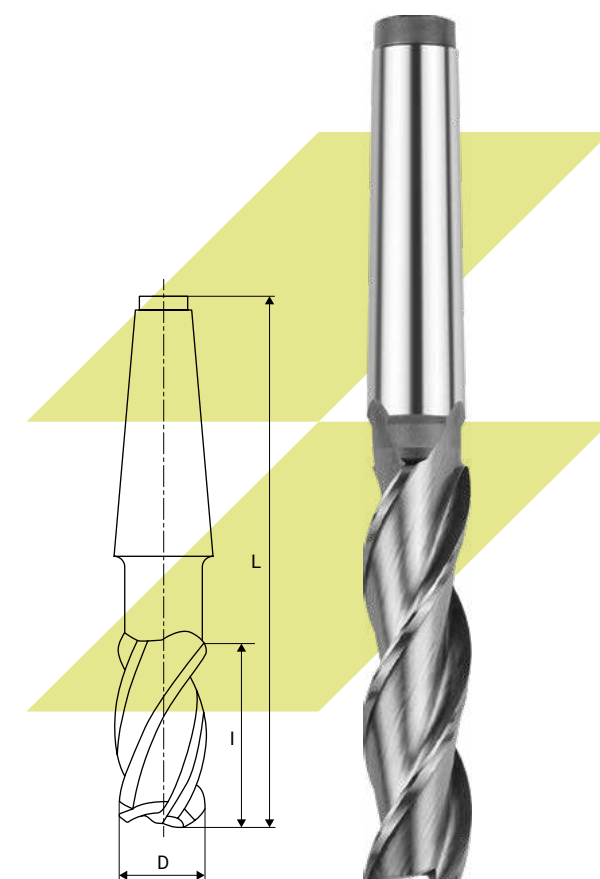

* Взамен действующим стандартам: ГОСТ 53002-2008, ГОСТ 17026-71

Фрезы концевые с коническим хвостовиком для обработки легких сплавов

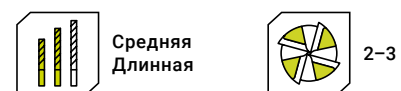
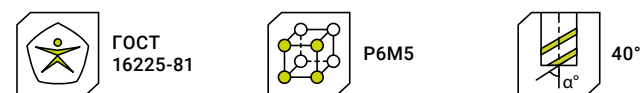
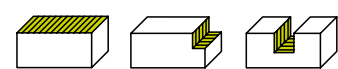

Артикул	Обозначение по ГОСТ	D, мм	I, мм	L, мм	Z, шт	КМ
1178251	—	8,0	26,0	108,0	2	КМ2
1178252	—	8,0	38,0	120,0	2	КМ2
1178253	—	10,0	22,0	104,0	2	КМ2
1179433	—	10,0	22,0	104,0	3	КМ2
1178254	—	10,0	45,0	127,0	2	КМ2
1178255	2223-1002	12,0	26,0	108,0	2	КМ2
1178256	2223-1004	12,0	53,0	135,0	2	КМ2
1178752	2223-1008	14,0	53,0	135,0	2	КМ2
1171757	2223-1062	14,0	53,0	138,0	3	КМ2
1178753	2223-1010	16,0	32,0	114,0	2	КМ2
1178754	2223-1063	16,0	32,0	114,0	3	КМ2
1171795	2223-1012	16,0	63,0	162,0	2	КМ3
1171791	2223-1064	16,0	63,0	148,0	3	КМ2
1171823	2223-1066	18,0	63,0	148,0	3	КМ2
1178257	2223-1018	20,0	38,0	137,0	2	КМ3
1171858	2223-1068	20,0	75,0	160,0	3	КМ2
1171899	2223-1070	22,0	75,0	177,0	3	КМ3
1178259	2223-1026	24,0	45,0	144,0	2	КМ3
1178241	2223-1071	24,0	45,0	147,0	3	КМ3
1178260	2223-1030	25,0	45,0	144,0	2	КМ3
1171938	2223-1074	25,0	90,0	192,0	3	КМ3
1178757	2223-1077	30,0	50,0	175,0	3	КМ4
1178758	2223-1042	32,0	53,0	178,0	2	КМ4
1178759	2223-1079	32,0	53,0	178,0	3	КМ4
1257969	2223-1044	32,0	106,0	231,0	2	КМ4
1178247	2223-1080	32,0	106,0	231,0	3	КМ4
1178761	2223-1081	36,0	53,0	178,0	3	КМ4
1178762	2223-1050	40,0	63,0	188,0	2	КМ4
1258262	2223-1084	40,0	125,0	250,0	3	КМ4
1178763	2223-1054	45,0	63,0	188,0	2	КМ4
1177785	2223-1056	45,0	125,0	250,0	2	КМ4
1178765	2223-1058	50,0	75,0	200,0	2	КМ4

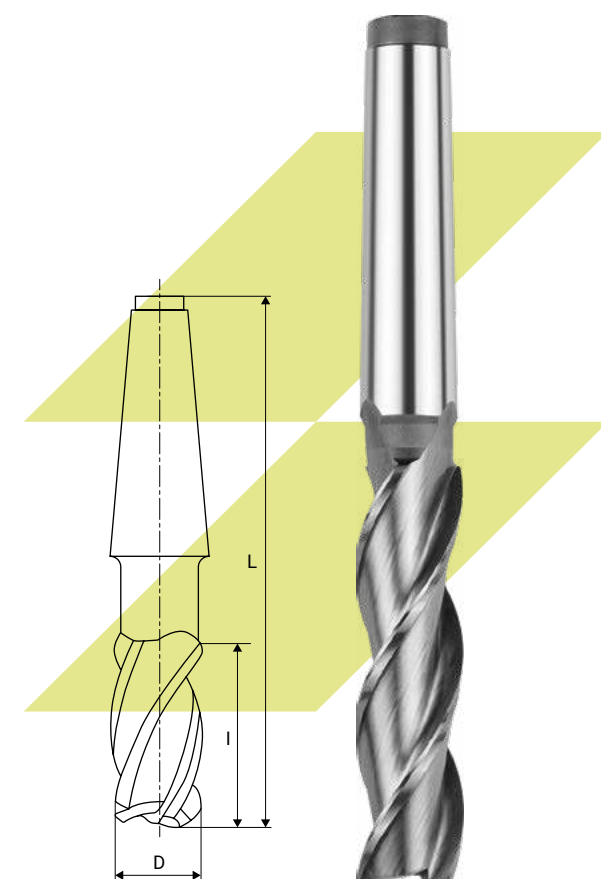

Фрезы концевые с коническим хвостовиком для обработки деталей из высокопрочных сталей и титановых сплавов

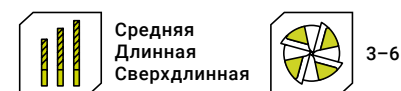
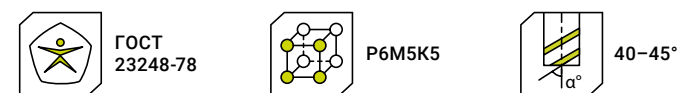
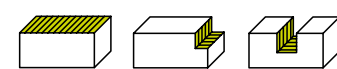

Артикул	D, мм	I, мм	L, мм	Z, шт	КМ
1418886	10,0	32,0	123,0	3	КМ2
1418888	10,0	38,0	129,0	3	КМ2
1253596	10,0	45,0	130,0	3	КМ2
1418889	10,0	45,0	136,0	3	КМ2
1418894	12,0	32,0	125,0	3	КМ2
1480555	12,0	45,0	138,0	3	КМ2
1418898	12,0	60,0	153,0	3	КМ2
1418903	14,0	38,0	131,0	3	КМ2
1418905	14,0	53,0	146,0	3	КМ2
1171766	14,0	70,0	152,0	3	КМ2
1425815	18,0	90,0	170,0	3	КМ2
1418921	20,0	38,0	146,0	3	КМ3
1337466	20,0	75,0	174,0	3	КМ3
1185716	20,0	75,0	195,0	6	КМ3
1418926	20,0	75,0	213,0	3	КМ4
1343091	20,0	80,0	188,0	3	КМ3
1343092	20,0	100,0	200,0	3	КМ3
1185718	20,0	100,0	205,0	6	КМ3
1171876	20,0	100,0	225,0	3	КМ4
1260658	22,0	75,0	200,0	3	КМ4
1276346	22,0	75,0	200,0	6	КМ3
1476946	24,0	90,0	189,0	3	КМ3
1185721	25,0	75,0	205,0	6	КМ4
1185722	25,0	90,0	220,0	6	КМ4
1185725	30,0	53,0	182,0	6	КМ4
1172005	30,0	90,0	215,0	6	КМ4
1172003	30,0	90,0	232,0	4	КМ4
1418938	32,0	53,0	226,0	4	КМ5
1185733	32,0	106,0	234,0	6	КМ4
1418943	32,0	106,0	279,0	4	КМ5
1172111	36,0	125,0	280,0	4	КМ5
1185736	40,0	75,0	245,0	6	КМ5
1476949	40,0	106,0	261,0	4	КМ5
1185741	45,0	75,0	230,0	6	КМ5

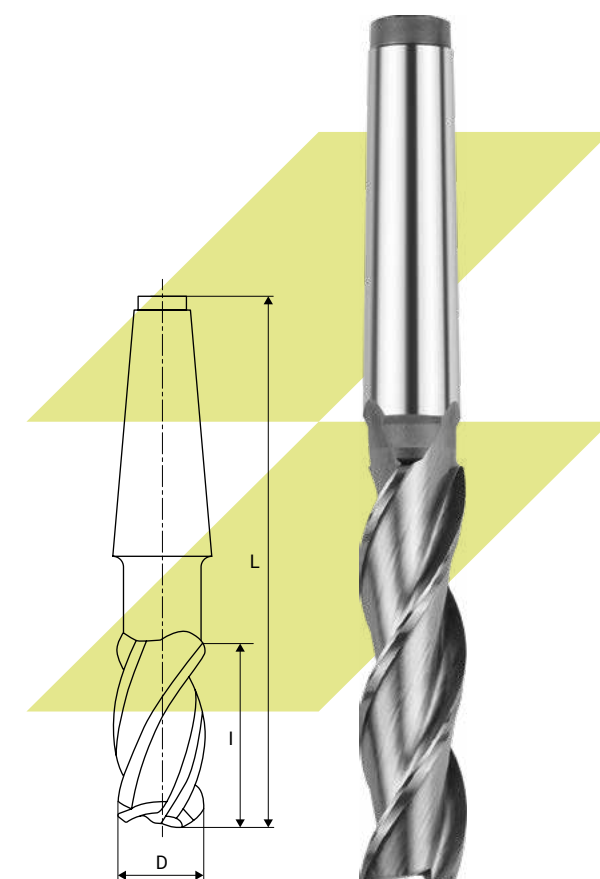

Артикул	D, мм	I, мм	L, мм	Z, шт	КМ
1172194	45,0	90,0	266,0	4	КМ5
1172197	45,0	110,0	286,0	4	КМ5
1583360	50,0	106,0	261,0	6	КМ5
1172259	50,0	150,0	308,0	6	КМ5
1418958	50,0	150,0	326,0	6	КМ5
1418960	50,0	180,0	356,0	6	КМ5
1582779	60,0	180,0	335,0	6	КМ5

Фрезы концевые с коническим хвостовиком, оснащенные прямыми твердосплавными пластинами. Средняя серия

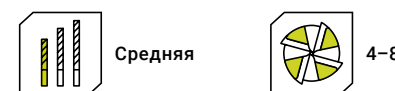
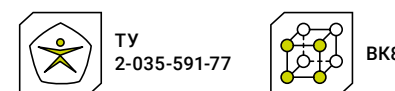
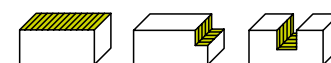

Артикул	D, мм	I, мм	L, мм	Z, шт	КМ
1178010	10,0	16,0	98,0	4	КМ1
1178012	12,0	16,0	98,0	4	КМ2
1178014	14,0	16,0	98,0	4	КМ2
1178018	18,0	19,0	101,0	4	КМ2
1178020	20,0	19,0	118,0	5	КМ3
1178023	22,0	19,0	118,0	5	КМ3
1178025	24,0	22,0	121,0	5	КМ3
1178027	25,0	22,0	121,0	5	КМ3
1178029	28,0	22,0	121,0	5	КМ3
1178031	30,0	22,0	147,0	5	КМ4
1261601	31,5	22,0	121,0	5	КМ3
1178033	31,5	22,0	147,0	5	КМ4
1178035	32,0	22,0	147,0	5	КМ4
1178037	36,0	25,0	150,0	6	КМ4
1178039	38,0	25,0	150,0	6	КМ4
1178041	40,0	25,0	150,0	6	КМ4
1172421	42,0	45,0	180,0	6	КМ4
1178043	45,0	30,0	157,0	6	КМ4
1178045	45,0	30,0	190,0	6	КМ5
1178047	50,0	30,0	157,0	6	КМ4
1178049	50,0	30,0	190,0	6	КМ5
1178779	70,0	70,0	230,0	8	КМ5
1172465	70,0	120,0	280,0	8	КМ5
1178052	80,0	30,0	200,0	8	КМ5
1179347	80,0	70,0	230,0	8	КМ5

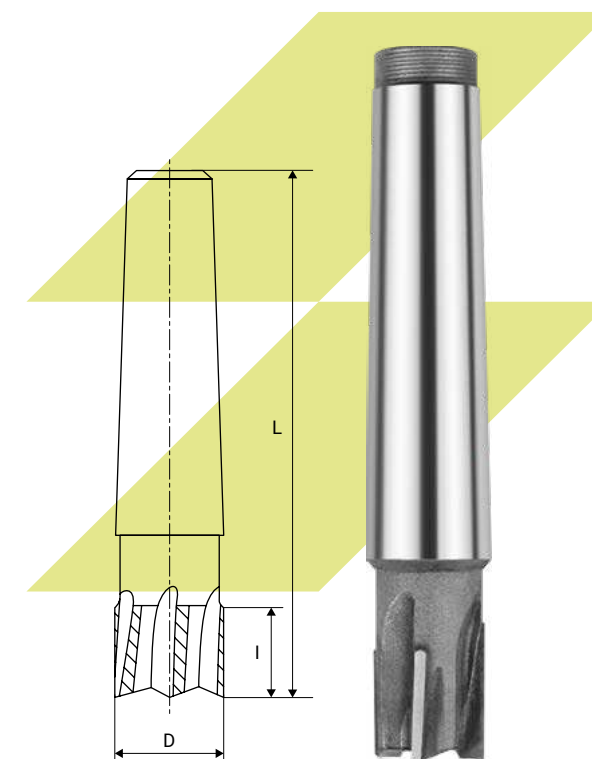

Фрезы концевые с коническим хвостовиком, оснащенные прямыми твердосплавными пластинами. Средняя серия

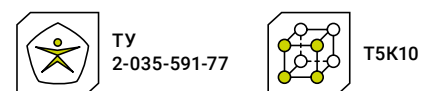
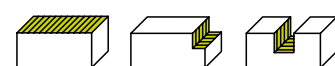

Артикул		D, мм	I, мм	L, мм	Z, шт	КМ
1178011	●	10,0	16,0	98,0	4	КМ1
1178013	●	12,0	16,0	98,0	4	КМ2
1178015	●	14,0	16,0	98,0	4	КМ2
1178016	●	16,0	16,0	98,0	4	КМ2
1178017	●	18,0	19,0	101,0	4	КМ2
1178019	●	20,0	19,0	101,0	5	КМ2
1178021	●	20,0	19,0	118,0	5	КМ3
1178022	●	22,0	19,0	101,0	5	КМ2
1178024	●	22,0	19,0	118,0	5	КМ3
1178026	●	24,0	22,0	121,0	5	КМ3
1178028	●	25,0	22,0	121,0	5	КМ3
1178030	●	28,0	22,0	121,0	5	КМ3
1178032	●	30,0	22,0	147,0	5	КМ4
1220283	●	31,5	22,0	121,0	5	КМ3
1178034	●	31,5	22,0	147,0	5	КМ4
1276660	●	32,0	22,0	121,0	5	КМ3
1178036	●	32,0	22,0	147,0	5	КМ4
1276661	●	36,0	25,0	124,0	6	КМ3
1178038	●	36,0	25,0	150,0	6	КМ4
1178040	●	38,0	25,0	150,0	6	КМ4
1178041	●	40,0	25,0	150,0	6	КМ4
1178044	●	45,0	30,0	157,0	6	КМ4
1178046	●	45,0	30,0	190,0	6	КМ5
1178048	●	50,0	30,0	157,0	6	КМ4
1178050	●	50,0	30,0	190,0	6	КМ5
1178780	●	70,0	70,0	230,0	8	КМ5
1178051	●	80,0	30,0	200,0	8	КМ5
1179348	●	80,0	70,0	230,0	8	КМ5

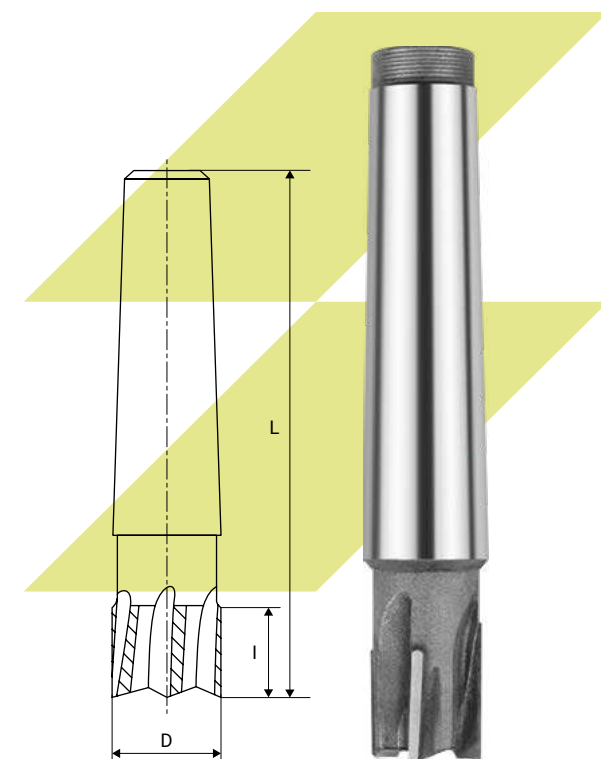

Фрезы концевые с коническим хвостовиком диаметром от 12,5 до 50 мм, оснащенные винтовыми твердосплавными пластинами. Средняя серия

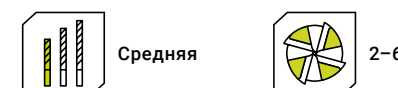
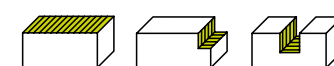

Артикул		Обозначение по ГОСТ	D, мм	I, мм	L, мм	Z, шт	КМ
1287034	●	2223-0501	12,5	14,0	115,0	2	КМ2
1172323	●	2223-0502	16,0	13,0	120,0	3	КМ2
1287019	●	2223-0503	20,0	12,0	135,0	4	КМ3
1287022	●	2223-0504	25,0	20,0	160,0	4	КМ4
1287025	●	2223-0505	32,0	19,0	160,0	4	КМ4
1287028	●	2223-0506	40,0	24,0	190,0	6	КМ5
1287031	●	2223-0507	50,0	22,0	190,0	6	КМ5

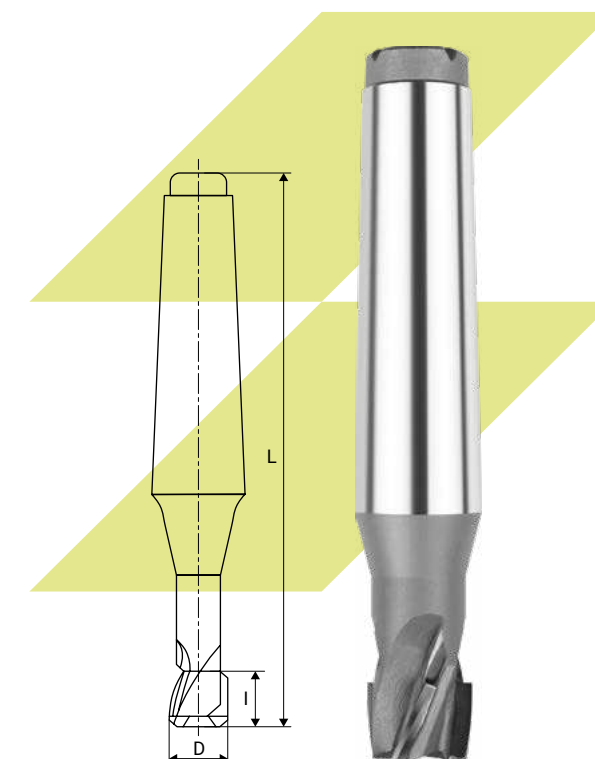

Фрезы концевые с коническим хвостовиком диаметром от 12,5 до 50 мм, оснащенные винтовыми твердосплавными пластинами. Средняя серия

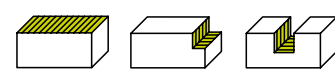

Артикул	Обозначение по ГОСТ	D, мм	I, мм	L, мм	Z, шт	КМ
1287035	2223-0501	12,5	14,0	115,0	2	КМ2
1172324	2223-0502	16,0	13,0	120,0	3	КМ2
1287020	2223-0503	20,0	12,0	135,0	4	КМ3
1287024	2223-0504	25,0	20,0	160,0	4	КМ4
1287027	2223-0505	32,0	19,0	160,0	4	КМ4
1287030	2223-0506	40,0	24,0	190,0	6	КМ5
1287033	2223-0507	50,0	22,0	190,0	6	КМ5

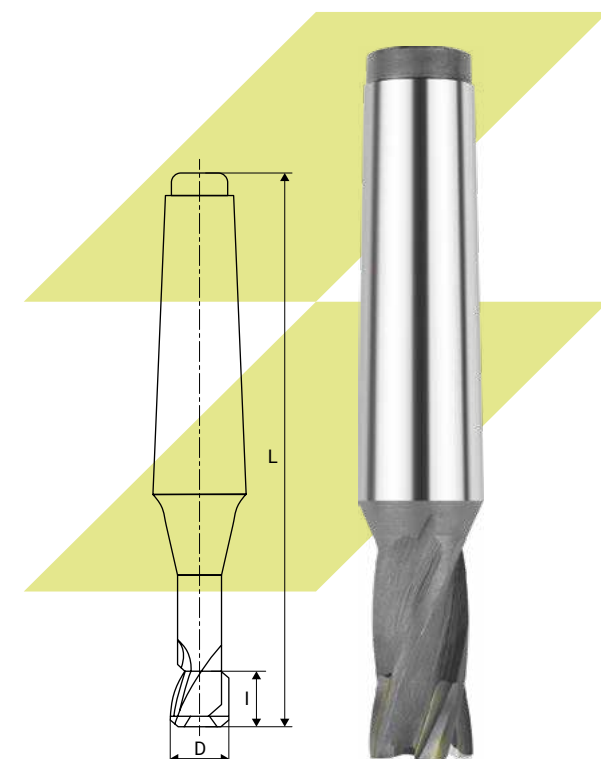

Фрезы концевые с коническим хвостовиком диаметром от 12,5 до 50 мм, оснащенные винтовыми твердосплавными пластинами. Средняя серия

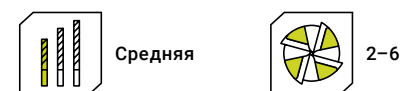
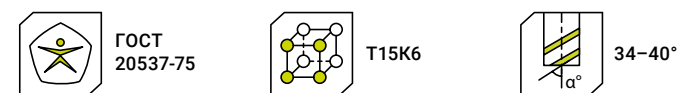
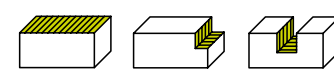

Артикул	Обозначение по ГОСТ	D, мм	I, мм	L, мм	Z, шт	КМ
1287021	2223-0503	20,0	12,0	135,0	4	КМ3
1287023	2223-0504	25,0	20,0	160,0	4	КМ4
1287026	2223-0505	32,0	19,0	160,0	4	КМ4
1287029	2223-0506	40,0	24,0	190,0	6	КМ5
1287032	2223-0507	50,0	22,0	190,0	6	КМ5

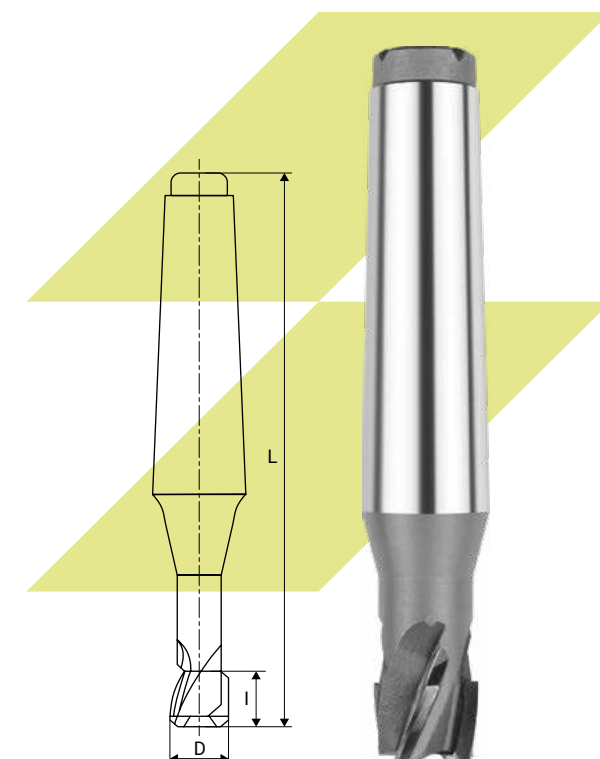

Фрезы концевые с коническим хвостовиком диаметром от 20 до 50 мм, оснащенные винтовыми твердосплавными пластинами. Средняя серия

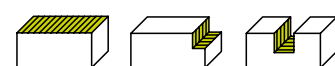

Артикул	Обозначение по ГОСТ	D, мм	I, мм	L, мм	Z, шт	КМ
1287036	2223-0551	20,0	21,0	145,0	4	КМ3
1179364	—	30,0	34,0	170,0	4	КМ4
1287039	2223-0553	32,0	34,0	170,0	4	КМ4
1287042	2223-0554	40,0	41,0	205,0	6	КМ5
1287045	2223-0555	50,0	38,0	205,0	6	КМ5

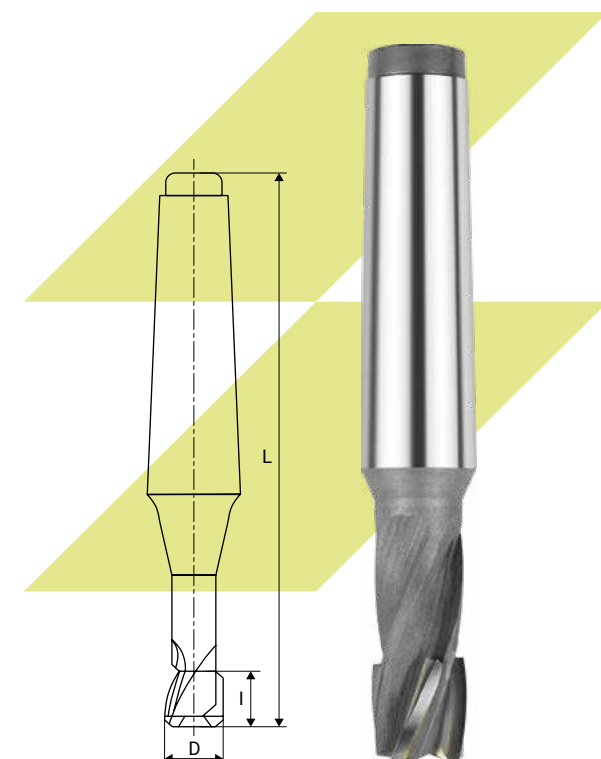

Фрезы концевые с коническим хвостовиком диаметром от 20 до 50 мм, с оснащенные винтовыми твердосплавными пластинами. Средняя серия

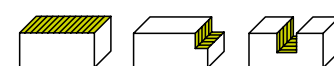

Артикул	Обозначение по ГОСТ	D, мм	I, мм	L, мм	Z, шт	КМ
1287037	2223-0551	20,0	21,0	136,0	4	КМ3
1287037	2223-0551	20,0	21,0	145,0	4	КМ3
1179365	—	30,0	34,0	170,0	4	КМ4
1287041	2223-0553	32,0	34,0	170,0	4	КМ4
1287044	2223-0554	40,0	41,0	205,0	6	КМ5
1287047	2223-0555	50,0	38,0	205,0	6	КМ5

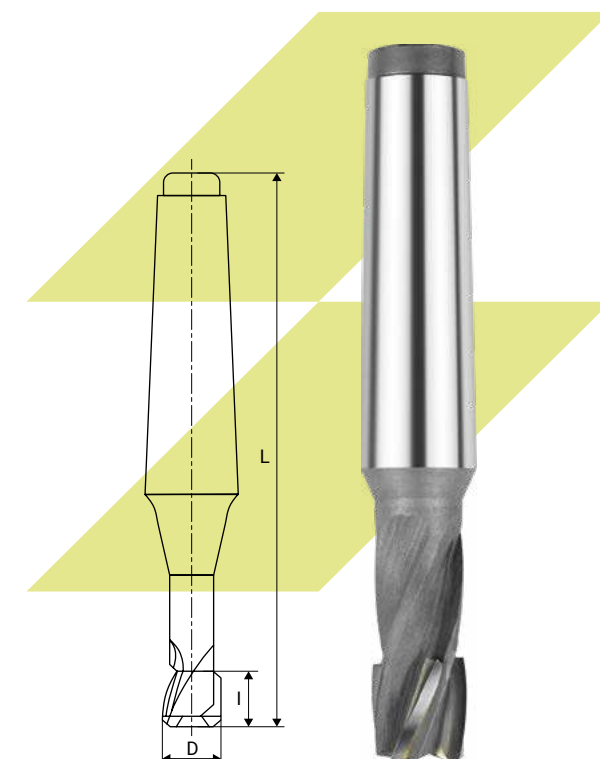

Фрезы концевые с коническим хвостовиком диаметром от 20 до 50 мм, оснащенные винтовыми твердосплавными пластинами. Средняя серия

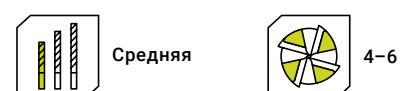
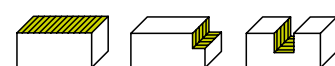

Артикул	Обозначение по ГОСТ	D, мм	I, мм	L, мм	Z, шт	КМ
1287038	2223-0551	20,0	21,0	145,0	4	КМ3
1287040	2223-0553	32,0	34,0	170,0	4	КМ4
1287043	2223-0554	40,0	41,0	205,0	6	КМ5
1287046	2223-0555	50,0	38,0	205,0	6	КМ5

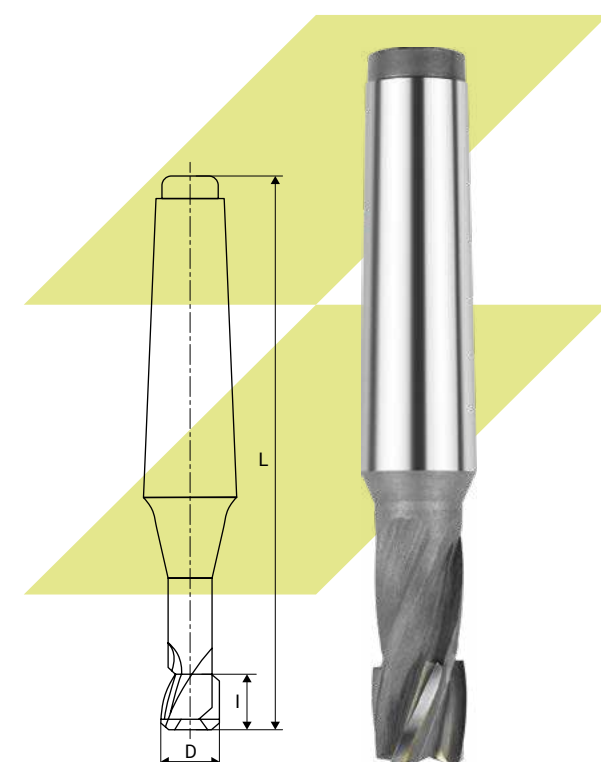

Фрезы концевые с коническим хвостовиком, оснащенные винтовыми твердосплавными пластинами, для обработки деталей из высокопрочных сталей и титановых сплавов

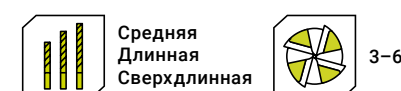
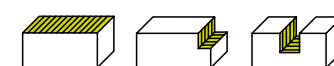

Артикул	Обозначение по ГОСТ	D, мм	I, мм	L, мм	Z, шт	КМ
1174892	—	16,0	32,0	117,0	3	КМ2
1178175	2223-5643	16,0	36,0	135,0	4	КМ3
1326122	—	18,0	37,0	136,0	4	КМ3
1176024	2223-5645	20,0	37,0	136,0	4	КМ3
1174894	—	20,0	38,0	140,0	3	КМ3
1176026	2223-5646	20,0	58,0	157,0	4	КМ3
1176028	2223-5648	22,0	37,0	162,0	4	КМ4
1174895	—	22,0	38,0	140,0	3	КМ3
1176030	2223-5649	22,0	58,0	183,0	4	КМ4
1176032	2223-5652	25,0	37,0	162,0	4	КМ4
1176033	2223-5653	25,0	58,0	183,0	4	КМ4
1176034	2223-5654	25,0	74,0	199,0	4	КМ4
1582246	—	30,0	34,0	170,0	4	КМ3
1179364	—	30,0	34,0	170,0	4	КМ4
1176036	—	30,0	53,0	178,0	4	КМ4
1176038	2223-5657	32,0	53,0	178,0	4	КМ4
1176039	2223-5658	32,0	72,0	197,0	4	КМ4
1176041	2223-5659	32,0	91,0	216,0	4	КМ4
1174898	—	40,0	53,0	178,0	4	КМ4
1342979	2223-5663	40,0	60,0	215,0	4	КМ5
1178183	2223-5668	40,0	60,0	215,0	6	КМ5
1178186	2223-5669	40,0	82,0	237,0	6	КМ5
1326123	2223-5671	40,0	104,0	259,0	6	КМ5
1174900	—	45,0	53,0	178,0	4	КМ4
1178188	—	45,0	60,0	215,0	6	КМ5
1178191	—	45,0	82,0	237,0	6	КМ5
1240754	2223-5674	50,0	60,0	215,0	4	КМ5
1240756	2223-5681	50,0	60,0	215,0	6	КМ5
1178775	2223-5675	50,0	82,0	237,0	4	КМ5
1178777	2223-5676	50,0	104,0	259,0	4	КМ5
1262886	2223-5683	50,0	104,0	259,0	6	КМ5

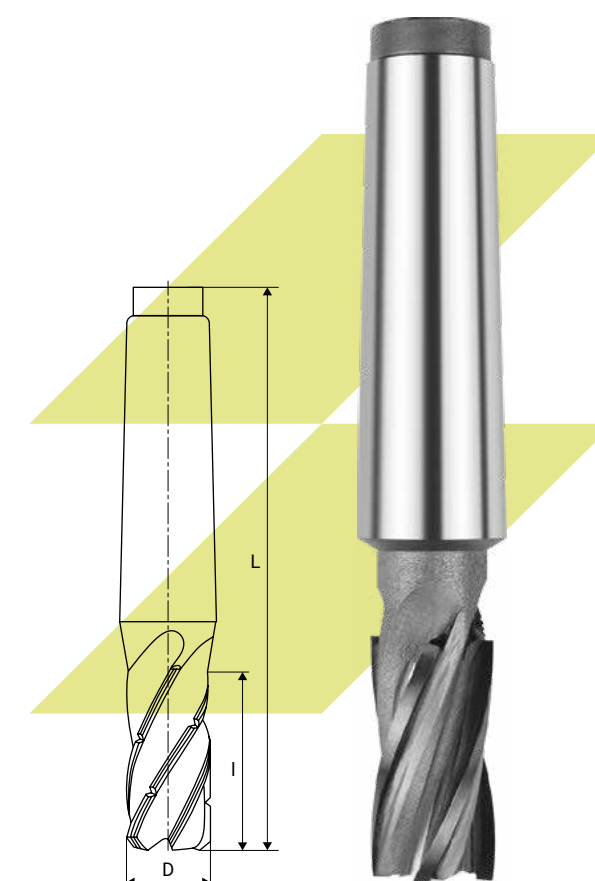

Фрезы концевые с коническим хвостовиком, оснащенные винтовыми твердосплавными пластинами, для обработки деталей из высокопрочных сталей и титановых сплавов

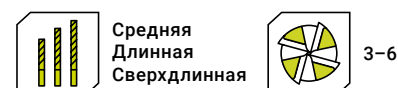
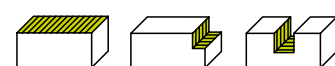

Артикул	Обозначение по ГОСТ	D, мм	I, мм	L, мм	Z, шт	КМ
1326121	—	16,0	32,0	117,0	3	КМ2
1342978	2223-5643	16,0	36,0	135,0	4	КМ3
1240463	—	18,0	37,0	136,0	4	КМ3
1176025	2223-5645	20,0	37,0	136,0	4	КМ3
1174893	—	20,0	38,0	140,0	3	КМ3
1176027	2223-5646	20,0	58,0	157,0	4	КМ3
1176029	2223-5648	22,0	37,0	162,0	4	КМ4
1174896	—	22,0	38,0	140,0	3	КМ3
1176031	2223-5649	22,0	58,0	183,0	4	КМ4
1178180	2223-5652	25,0	37,0	162,0	4	КМ4
1178181	2223-5653	25,0	58,0	183,0	4	КМ4
1176035	2223-5654	25,0	74,0	199,0	4	КМ4
1179365	—	30,0	34,0	170,0	4	КМ4
1176037	—	30,0	53,0	178,0	4	КМ4
1376531	2223-5658	32,0	72,0	197,0	4	КМ3
1176040	2223-5658	32,0	72,0	197,0	4	КМ4
1176042	2223-5659	32,0	91,0	216,0	4	КМ4
1174897	—	40,0	53,0	178,0	4	КМ4
1342980	2223-5663	40,0	60,0	215,0	4	КМ5
1178185	2223-5668	40,0	60,0	215,0	6	КМ5
1377069	2223-5664	40,0	82,0	237,0	4	КМ5
1178187	2223-5669	40,0	82,0	237,0	6	КМ5
1293062	2223-5671	40,0	104,0	259,0	6	КМ5
1174899	—	45,0	53,0	178,0	4	КМ4
1178190	—	45,0	60,0	215,0	6	КМ5
1178192	—	45,0	82,0	237,0	6	КМ5
1240755	2223-5674	50,0	60,0	215,0	4	КМ5
1284480	2223-5681	50,0	60,0	215,0	6	КМ5
1178776	2223-5675	50,0	82,0	237,0	4	КМ5
1178778	2223-5676	50,0	104,0	259,0	4	КМ5
1262887	2223-5683	50,0	104,0	259,0	6	КМ5
1293063	2223-5684	50,0	142,0	297,0	6	КМ5

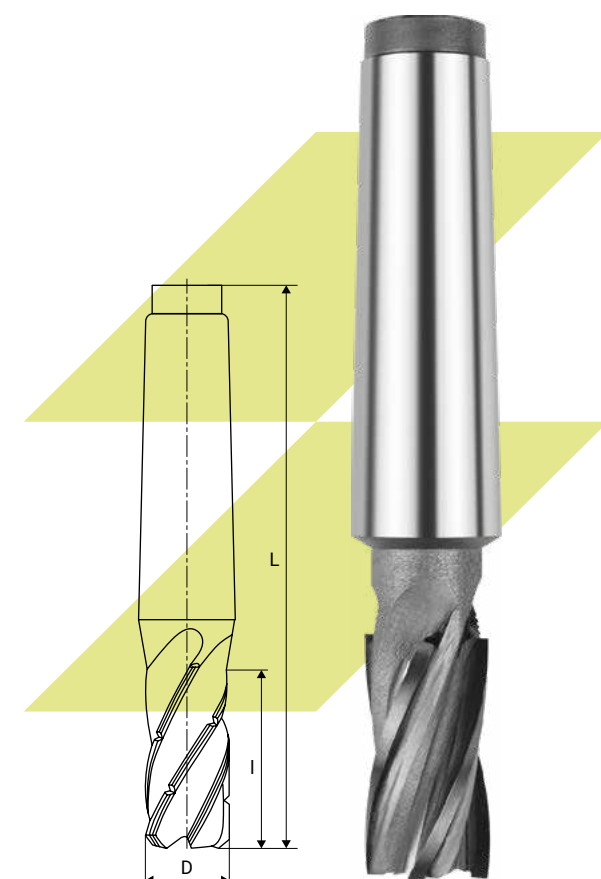

Фрезы концевые с коническим хвостовиком, оснащенные винтовыми твердосплавными пластинами, для обработки деталей из высокопрочных сталей и титановых сплавов

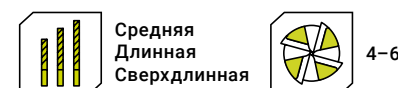
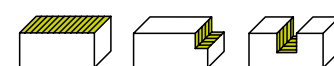

Артикул	Обозначение по ГОСТ	D, мм	I, мм	L, мм	Z, шт	КМ
1178177	2223-5645	20,0	37,0	136,0	4	КМ3
1377784	2223-5646	20,0	58,0	157,0	4	КМ3
1178178	2223-5648	22,0	37,0	162,0	4	КМ4
1178179	2223-5652	25,0	37,0	162,0	4	КМ4
1377785	2223-5653	25,0	58,0	183,0	4	КМ4
1582247	—	30,0	34,0	170,0	4	КМ4
1377786	—	30,0	53,0	178,0	4	КМ4
1178182	2223-5657	32,0	53,0	178,0	4	КМ4
1178773	2223-5668	40,0	60,0	215,0	6	КМ5
1178774	—	45,0	60,0	215,0	6	КМ5
1178193	2223-5681	50,0	60,0	215,0	6	КМ5
1326124	2223-5683	50,0	104,0	259,0	6	КМ5

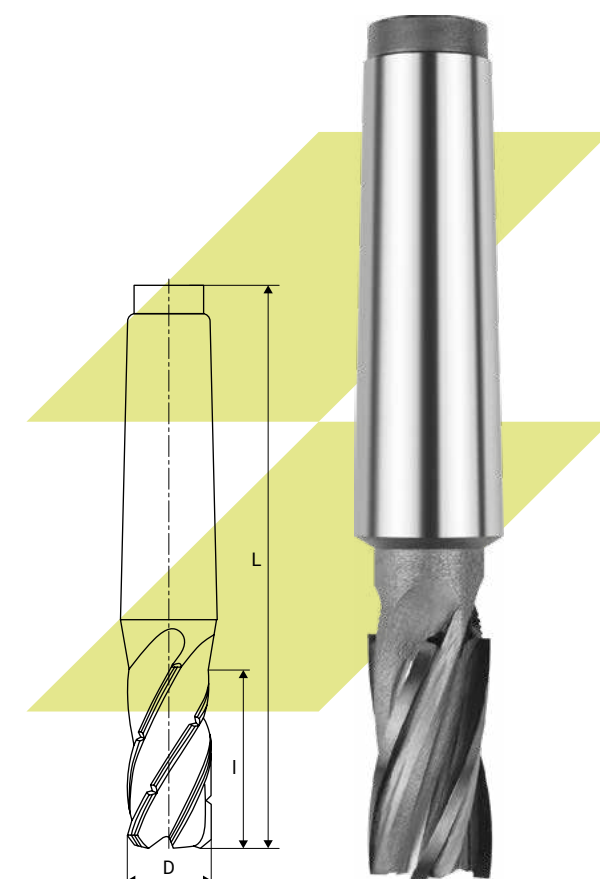

Фрезы шпоночные с цилиндрическим хвостовиком из быстрорежущей стали. Средняя серия

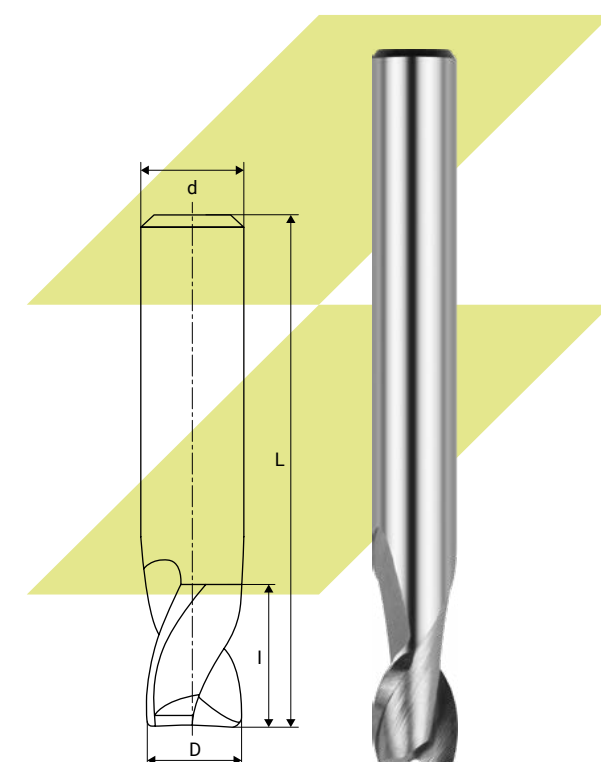
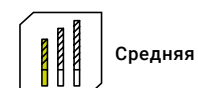
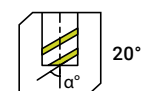
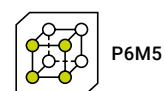

Артикул	Обозначение по ГОСТ	D, мм	d, мм	I, мм	L, мм
1172487	—	1,7	2,0	4,0	25,0
1172488	2234-0341	2,0	2,0	4,0	36,0
1287017	2334-0343	2,0	4,0	4,0	36,0
1335767	—	2,0	4,0	7,0	39,0
1172489	—	2,0	2,0	9,0	36,0
1172491	2234-0345	3,0	3,0	5,0	37,0
1287018	2234-0347	3,0	4,0	5,0	37,0
1335768	—	3,0	4,0	8,0	40,0
1172493	2234-0351	4,0	4,0	7,0	39,0
1335769	—	4,0	4,0	11,0	43,0
1172497	2234-0353	5,0	5,0	8,0	42,0
1335770	—	5,0	5,0	13,0	47,0
1172505	2234-0355	6,0	6,0	8,0	52,0
1335771	—	6,0	6,0	13,0	57,0
1174810	2234-0361	7,0	7,0	10,0	54,0
1172510	2234-0363	8,0	8,0	11,0	55,0
1335772	—	8,0	8,0	19,0	63,0
1174809	—	9,0	10,0	16,0	62,0
1415809	—	9,0	10,0	11,0	61,0
1172515	2234-0365	10,0	10,0	13,0	63,0
1276662	—	10,0	10,0	22,0	72,0
1378436	—	11,0	12,0	13,0	70,0
1378437	—	11,0	12,0	22,0	79,0
1172519	2234-0367	12,0	12,0	16,0	73,0
1276663	—	12,0	12,0	26,0	83,0
1172523	2234-0371	14,0	14,0	16,0	73,0
1276664	—	14,0	14,0	26,0	83,0
1172530	2234-0375	16,0	16,0	19,0	79,0
1335773	—	16,0	16,0	32,0	92,0
1172534	2234-0377	18,0	18,0	19,0	79,0
1335774	—	18,0	18,0	32,0	92,0
1172539	2234-0383	20,0	20,0	22,0	88,0
1335775	—	20,0	20,0	38,0	104,0
1172542	2234-0385	22,0	25,0	22,0	88,0

Артикул	Обозначение по ГОСТ	D, мм	d, мм	I, мм	L, мм
1417644	—	24,0	25,0	26,0	102,0
1172545	2234-0387	25,0	25,0	26,0	102,0

Фрезерование

Фрезерование

Фрезы шпоночные с цилиндрическим хвостовиком из быстрорежущей стали. Средняя серия

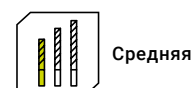
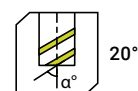

Артикул	Обозначение по ГОСТ	D, мм	d, мм	l, мм	L, мм
1335703	2334-0343	2,0	4,0	4,0	36,0
1335704	2234-0347	3,0	4,0	5,0	37,0
1335705	2234-0351	4,0	4,0	7,0	39,0
1335706	2234-0353	5,0	5,0	8,0	40,0
1335707	—	6,0	6,0	10,0	45,0
1335708	—	8,0	8,0	11,0	50,0
1335709	—	10,0	10,0	13,0	60,0
1335710	—	12,0	12,0	16,0	70,0
1335711	—	14,0	14,0	16,0	70,0
1335712	2234-0375	16,0	16,0	19,0	79,0
1335713	2234-0377	18,0	18,0	19,0	79,0
1335714	2234-0383	20,0	20,0	22,0	88,0
1335715	2234-0385	22,0	25,0	22,0	88,0
1335716	2234-0387	25,0	25,0	26,0	102,0

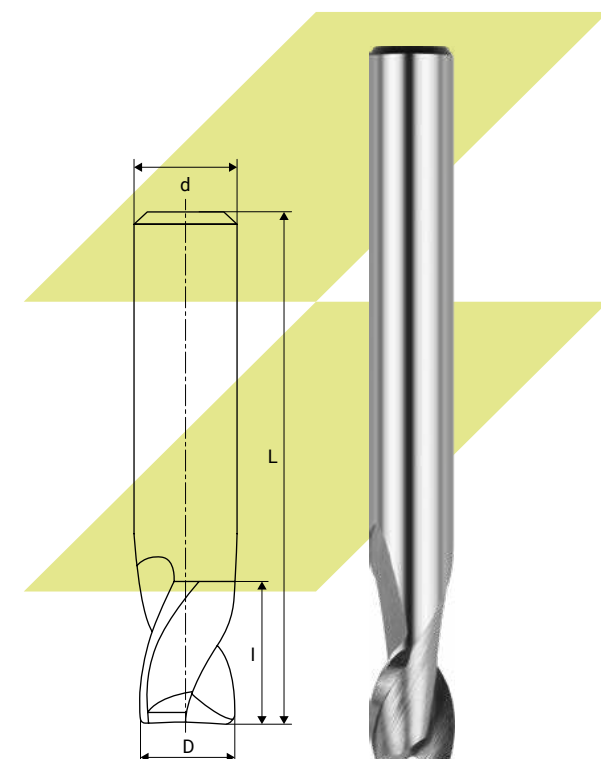

Фрезы шпоночные с цилиндрическим хвостовиком, оснащенные твердосплавными пластинами. Средняя серия

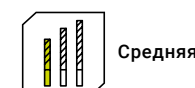
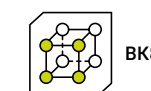
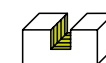

Артикул	Обозначение по ГОСТ	D, мм	d, мм	l, мм	L, мм
1178194	2234-0133	10,0	10,0	12,0	62,0
1178196	2234-0135	12,0	12,0	16,0	73,0
1337471	2234-0137	14,0	12,0	16,0	73,0
1346050	2234-0141	16,0	16,0	16,0	76,0
1220854	2234-0143	18,0	16,0	19,0	79,0
1178201	2234-0145	20,0	20,0	19,0	85,0

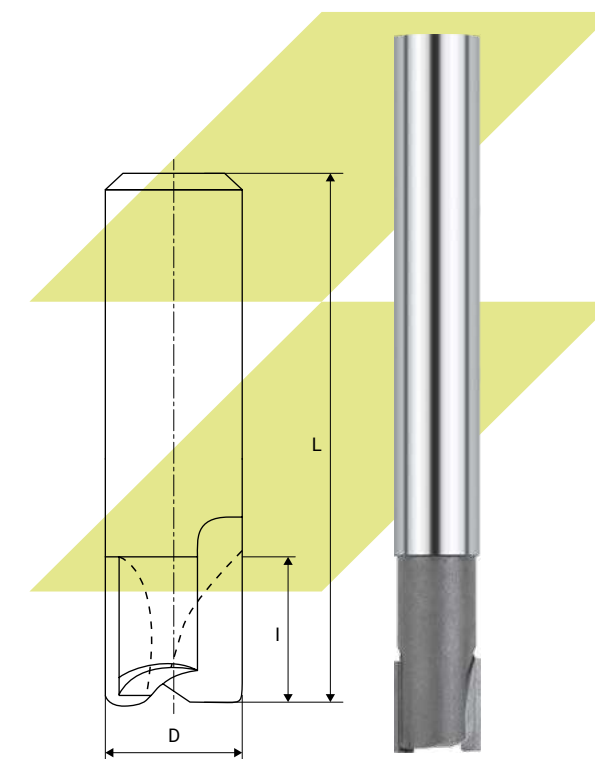

Фрезы шпоночные с цилиндрическим хвостовиком, оснащенные твердосплавными пластинами. Средняя серия

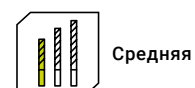

Артикул	Обозначение по ГОСТ	D, мм	d, мм	l, мм	L, мм
1178195	2234-0133	10,0	10,0	12,0	62,0
1178197	2234-0135	12,0	12,0	16,0	73,0
1178198	2234-0137	14,0	12,0	16,0	73,0
1178199	2234-0141	16,0	16,0	16,0	76,0
1178200	2234-0143	18,0	16,0	19,0	79,0
1178202	2234-0145	20,0	20,0	19,0	85,0

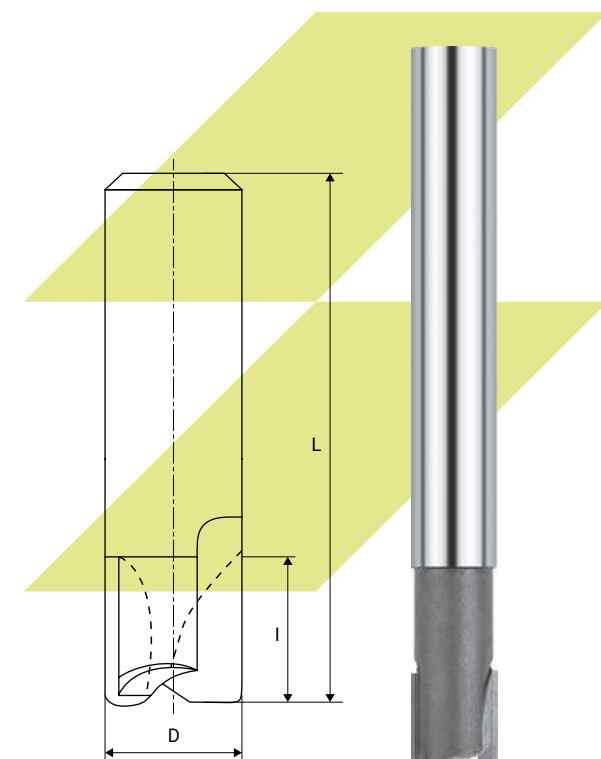

Фрезы шпоночные цельные твердосплавные. Средняя серия

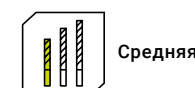
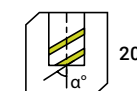
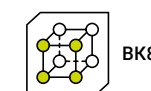

Артикул	Обозначение по ГОСТ	D, мм	d, мм	l, мм	L, мм
1417837	—	2,0	2,0	4,0	25,0
1267135	2234-0201	2,0	3,0	4,0	25,0
1267136	2234-0501	2,0	4,0	5,0	25,0
1267137	2234-0202	3,0	3,0	5,0	30,0
1267138	2234-0502	3,0	4,0	5,0	30,0
1175743	—	3,0	3,0	8,0	50,0
1267139	2234-0203	4,0	4,0	7,0	32,0
1267140	2234-0204	5,0	5,0	8,0	32,0
1267141	2234-0205	6,0	6,0	10,0	35,0
1265723	2234-0503	7,0	7,0	10,0	35,0
1267143	2234-0504	7,0	8,0	10,0	35,0
1267144	2234-0206	8,0	8,0	11,0	40,0
1267145	2234-0207	10,0	10,0	13,0	45,0
1175748	—	10,0	10,0	25,0	75,0
1267146	2234-0208	12,0	12,0	16,0	50,0
1175749	—	12,0	12,0	30,0	75,0

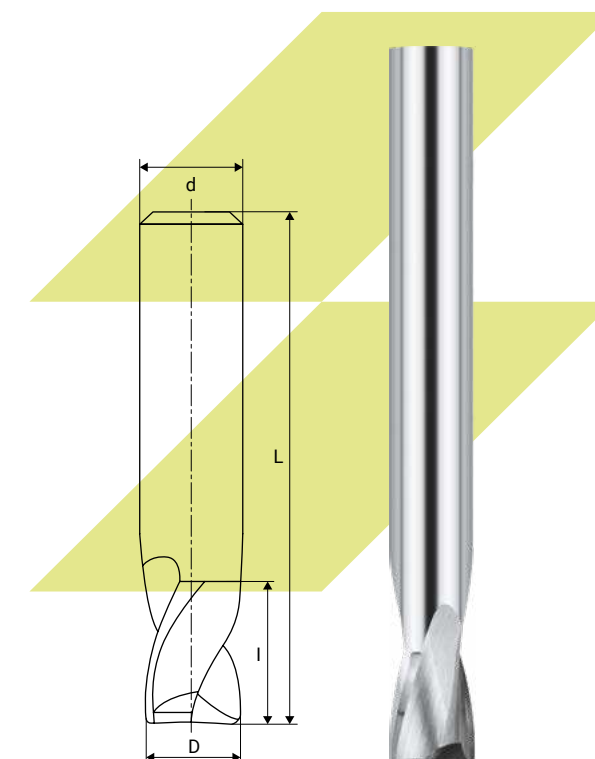

Фрезы шпоночные с коническим хвостовиком из быстрорежущей стали. Средняя серия

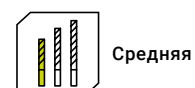
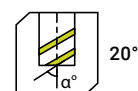
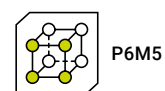

Артикул	Обозначение по ГОСТ	D, мм	I, мм	L, мм	КМ
1335776	—	8,0	19,0	89,0	КМ1
1172548	2235-0037	10,0	13,0	83,0	КМ1
1172550	2235-0041	12,0	16,0	86,0	КМ1
1260315	2235-0043	12,0	16,0	101,0	КМ2
1260316	2235-0045	14,0	16,0	86,0	КМ1
1172552	2235-0047	14,0	16,0	101,0	КМ2
1172558	2235-0051	16,0	19,0	104,0	КМ2
1172564	2235-0053	18,0	19,0	104,0	КМ2
1172573	2235-0055	20,0	22,0	107,0	КМ2
1260317	2235-0057	20,0	22,0	124,0	КМ3
1172577	2235-0061	22,0	22,0	107,0	КМ2
1260318	2235-0063	22,0	22,0	124,0	КМ3
1172581	—	24,0	26,0	128,0	КМ3
1172586	2235-0065	25,0	26,0	128,0	КМ3
1172592	2235-0067	28,0	26,0	128,0	КМ3
1172595	—	30,0	32,0	134,0	КМ3
1172599	2235-0073	32,0	32,0	134,0	КМ3
1260319	2235-0075	32,0	32,0	157,0	КМ4
1260320	2235-0077	36,0	32,0	134,0	КМ3
1172604	2235-0081	36,0	32,0	157,0	КМ4
1172609	2235-0083	40,0	38,0	163,0	КМ4
1172612	—	45,0	43,0	168,0	КМ4
1172614	—	50,0	43,0	168,0	КМ4

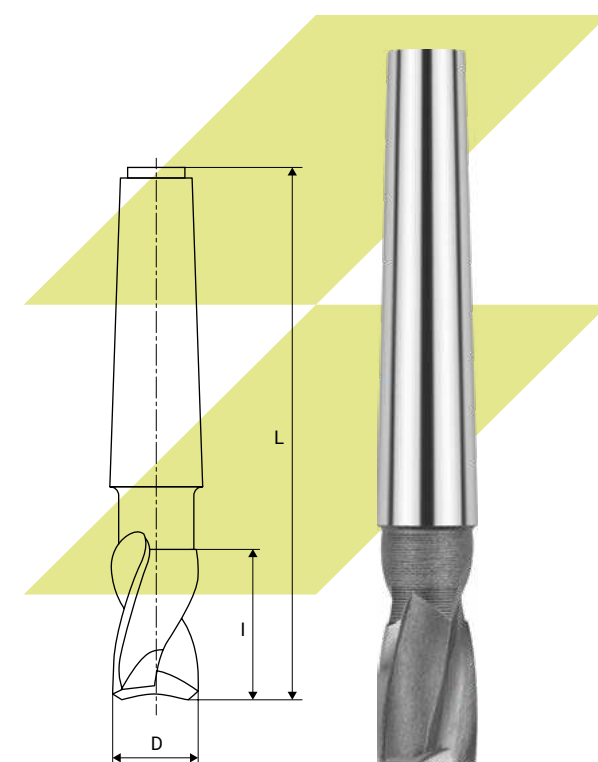

Фрезы шпоночные с коническим хвостовиком из быстрорежущей стали. Средняя серия

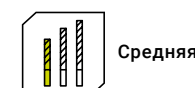
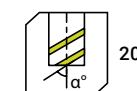
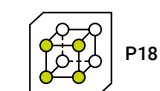

Артикул	Обозначение по ГОСТ	D, мм	I, мм	L, мм	КМ
1335717	2235-0037	10,0	13,0	83,0	КМ1
1335718	2235-0041	12,0	16,0	86,0	КМ1
1335719	2235-0045	14,0	16,0	86,0	КМ1
1172570	—	20,0	30,0	110,0	КМ2
1335720	2235-0061	22,0	22,0	107,0	КМ2
1335721	2235-0065	25,0	26,0	128,0	КМ3
1335722	2235-0067	28,0	26,0	128,0	КМ3
1335723	2235-0073	32,0	32,0	134,0	КМ3
1335724	2235-0077	36,0	32,0	134,0	КМ3
1335725	2235-0081	36,0	32,0	157,0	КМ4
1335726	2235-0083	40,0	38,0	163,0	КМ4

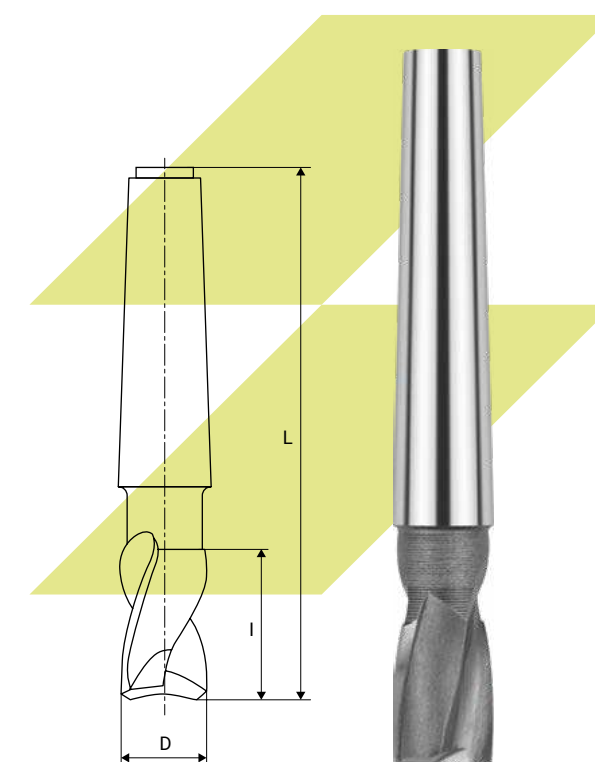

Фрезы шпоночные с коническим хвостовиком из быстрорежущей стали. Длинная серия



ГОСТ 9140-2015



P6M5

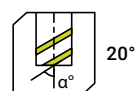

20°

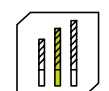

Длинная



2

Артикул		D, мм	I, мм	L, мм	KM
1335777	●	10,0	22,0	92,0	KM1
1335778	●	12,0	26,0	96,0	KM1
1378403	●	12,0	26,0	111,0	KM2
1335779	●	14,0	26,0	111,0	KM2
1335780	●	16,0	32,0	117,0	KM2
1335781	●	18,0	32,0	117,0	KM2
1335782	●	20,0	38,0	123,0	KM2
1335783	●	22,0	38,0	123,0	KM2
1335784	●	24,0	45,0	147,0	KM3
1335785	●	25,0	45,0	147,0	KM3
1335786	●	28,0	45,0	147,0	KM3
1335787	●	32,0	53,0	155,0	KM3
1335788	●	36,0	53,0	178,0	KM4
1335789	●	40,0	63,0	188,0	KM4
1335790	●	45,0	63,0	188,0	KM4
1335791	●	50,0	75,0	200,0	KM4

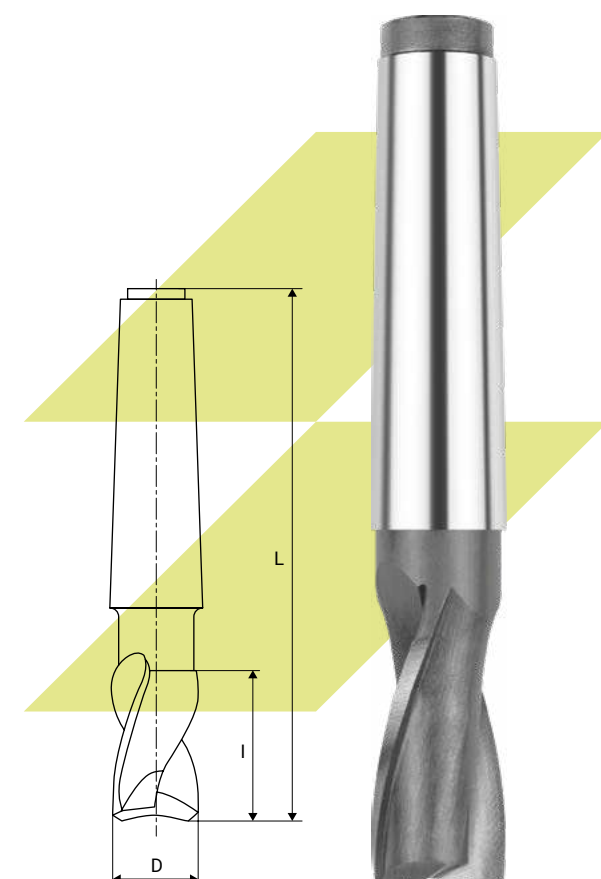

Фрезы шпоночные с коническим хвостовиком, оснащенные твердосплавными пластинами. Средняя серия



ГОСТ 6396-78



VK8

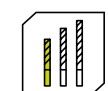

Средняя



2

Артикул		Обозначение по ГОСТ	D, мм	I, мм	L, мм	KM
1178203	●	2235-0193	12,0	16,0	101,0	KM2
1416758	●	2235-0201	16,0	16,0	101,0	KM2
1416759	●	2235-0203	18,0	19,0	104,0	KM2
1178206	●	2235-0205	20,0	19,0	104,0	KM2
1418730	●	2235-0211	22,0	19,0	104,0	KM2
1269474	●	2235-0213	22,0	19,0	121,0	KM3
1416760	●	—	24,0	22,0	124,0	KM3
1418732	●	2235-0215	25,0	22,0	124,0	KM3
1418734	●	2235-0217	28,0	22,0	124,0	KM3
1418736	●	2235-0227	36,0	25,0	127,0	KM3
1172613	●	—	50,0	30,0	220,0	KM5

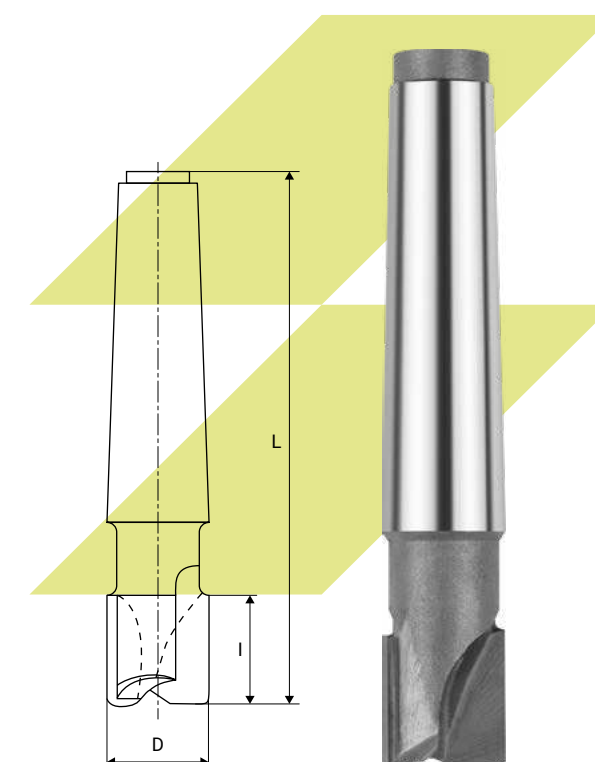

Фрезы шпоночные с коническим хвостовиком, оснащенные твердосплавными пластинами. Средняя серия

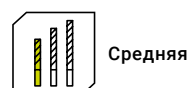

Артикул	Обозначение по ГОСТ	D, мм	I, мм	L, мм	KM
1276658	2235-0191	12,0	16,0	86,0	KM1
1178204	2235-0193	12,0	16,0	101,0	KM2
1418729	2235-0195	14,0	16,0	86,0	KM1
1178205	2235-0201	16,0	16,0	101,0	KM2
1178207	2235-0205	20,0	19,0	104,0	KM2
1276659	2235-0207	20,0	19,0	121,0	KM3
1418731	2235-0211	22,0	19,0	104,0	KM2
1342934	2235-0213	22,0	19,0	121,0	KM3
1418733	2235-0215	25,0	22,0	124,0	KM3
1418735	2235-0217	28,0	22,0	124,0	KM3
1378546	—	28,0	22,0	150,0	KM4
1178208	2235-0223	32,0	22,0	124,0	KM3
1178209	2235-0227	36,0	25,0	127,0	KM3
1178210	2235-0233	40,0	25,0	150,0	KM4

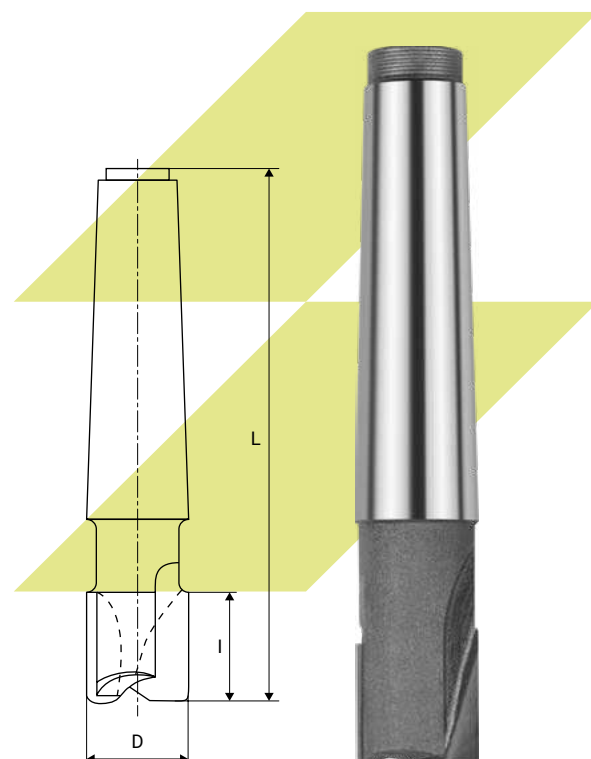

Фрезы для обработки пазов типа «Ласточкин хвост» из быстрорежущей стали

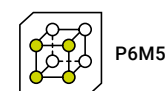

Артикул	D, мм	d, мм	I, мм	L, мм	α°	Z, шт
1179958	16,0	12,0	4,0	60,0	45	6
1179963	16,0	12,0	6,3	60,0	60	6
1179959	20,0	12,0	5,0	63,0	45	8
1179964	20,0	12,0	8,0	63,0	60	8
1425185	20,0	12,0	8,0	63,0	60	10
1179960	25,0	12,0	6,3	67,0	45	10
1179965	25,0	12,0	10,0	67,0	60	10
1179961	32,0	16,0	8,0	71,0	45	12
1179966	32,0	16,0	12,5	71,0	60	12
1179962	40,0	16,0	10,0	71,0	45	14
1179967	40,0	16,0	16,0	71,0	60	14

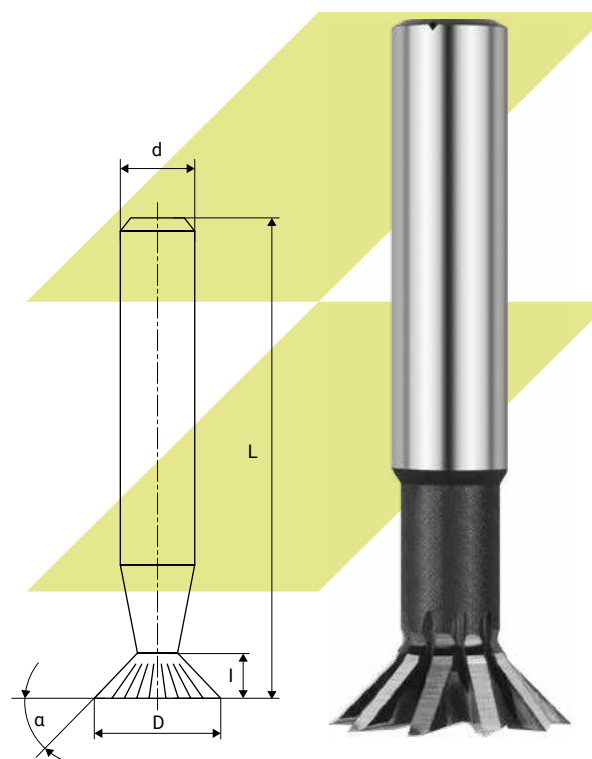

Фрезы для обработки пазов типа перевернутый «Ласточкин хвост» из быстрорежущей стали

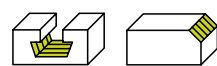

Артикул		D, мм	d, мм	l, мм	L, мм	α°	Z, шт
1179968		16,0	12,0	4,0	60,0	45	6
1179973		16,0	12,0	6,3	60,0	60	6
1179969		20,0	12,0	5,0	63,0	45	8
1179974		20,0	12,0	8,0	63,0	60	8
1179970		25,0	12,0	6,3	67,0	45	10
1179975		25,0	12,0	10,0	67,0	60	10
1179971		32,0	16,0	8,0	71,0	45	12
1179976		32,0	16,0	12,5	71,0	60	12
1179972		40,0	16,0	10,0	71,0	45	14
1179977		40,0	16,0	16,0	71,0	60	14

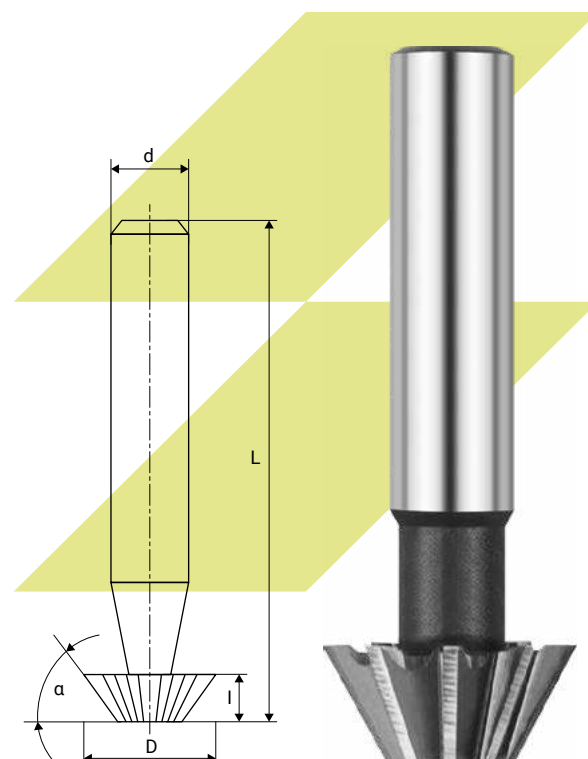

Фрезы для обработки пазов сегментных шпонок из быстрорежущей стали

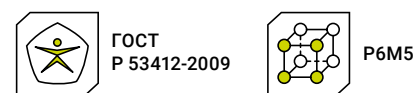
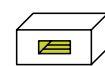

Артикул		D, мм	d, мм	d ₁ , мм	l, мм	L, мм	Z, шт
1261598		4,0	6,0	1,8	1,0	50,0	6
1261599		7,0	6,0	2,8	1,5	50,0	6
1261600		7,0	6,0	3,2	2,0	50,0	6
1220079		10,0	6,0	4,0	2,0	50,0	6
1220080		10,0	6,0	4,0	2,5	50,0	6
1582488		13,0	10,0	4,6	3,0	56,0	6
109979		13,0	10,0	4,6	4,0	56,0	6
1418398		16,0	10,0	4,6	3,0	56,0	8
1479839		22,0	10,0	10,0	4,0	63,0	8
1418399		22,0	10,0	6,0	5,0	63,0	8
1220081		22,0	10,0	6,5	6,0	63,0	8
1220082		22,0	10,0	10,0	8,0	63,0	8
1425122		25,0	10,0	10,0	5,0	63,0	8
1418400		25,0	10,0	7,5	6,0	63,0	8
1425123		28,0	10,0	10,0	5,0	63,0	8
109995		28,0	10,0	8,5	8,0	63,0	8
1418401		32,0	12,0	9,3	10,0	71,0	10

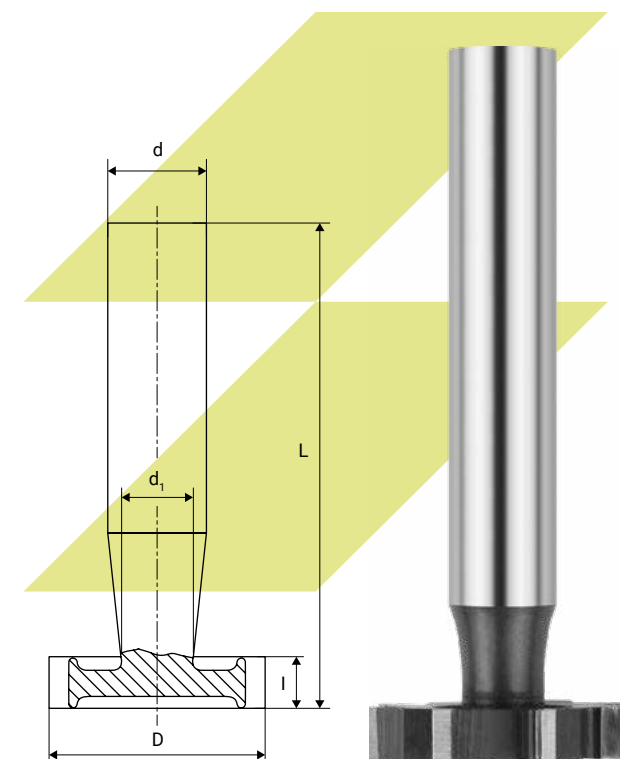

Фрезы с цилиндрическим хвостовиком для обработки Т-образных пазов из быстрорежущей стали

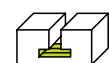

ГОСТ 7063-72



P6M5



6-8

Артикул	Обозначение по ГОСТ	Паз мм	D, мм	I, мм	d, мм	d ₁ , мм	I ₁ , мм	L, мм	Z, шт
1377914	2252-0401	5,0	11,0	3,5	10,0	4,0	10,0	53,5	6
1325976	2252-0301	6,0	12,5	6,0	10,0	5,0	10,0	57,0	6
1236397	2252-0302	8,0	16,0	8,0	10,0	7,0	13,0	62,0	6
1325977	2252-0303	10,0	18,0	8,0	12,0	8,0	17,0	70,0	6
1330949	2252-0304	12,0	21,0	9,0	12,0	10,0	20,0	74,0	8
1330950	2252-0305	14,0	25,0	11,0	16,0	12,0	23,0	82,0	8
1330951	2252-0306	18,0	32,0	14,0	16,0	15,0	27,0	90,0	8
1330952	2252-0307	22,0	40,0	18,0	25,0	19,0	18,0	108,0	8
1377915	2252-0402	28,0	50,0	22,0	32,0	25,0	42,0	124,0	8
1377916	2252-0403	36,0	60,0	28,0	32,0	30,0	51,0	139,0	8

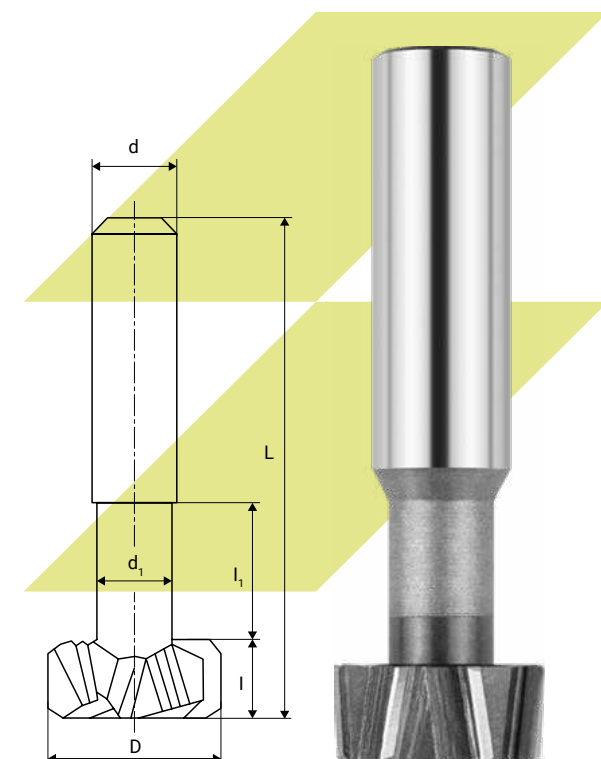

Фрезы с коническим хвостовиком для обработки Т-образных пазов из быстрорежущей стали

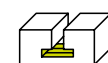

ГОСТ 7063-72



P6M5



4-8

Артикул	Обозначение по ГОСТ	Паз мм	D, мм	I, мм	d ₁ , мм	L, мм	KM	Z, шт
1269812	2252-0151	6,0	12,5	6,0	5,0	73,0	KM1	6
1269813	2252-0152	8,0	16,0	7,0	7,0	77,0	KM1	6
1269814	2252-0154	10,0	18,0	8,0	8,0	82,0	KM1	4
1269815	2252-0153	10,0	18,0	8,0	8,0	82,0	KM1	6
1330953	2252-0156	12,0	21,0	9,0	10,0	98,0	KM2	6
1330954	2252-0155	12,0	21,0	9,0	10,0	98,0	KM2	8
1269817	2252-0158	14,0	25,0	11,0	12,0	103,0	KM2	6
1269818	2252-0157	14,0	25,0	11,0	12,0	103,0	KM2	8
1330955	2252-0160	18,0	32,0	14,0	15,0	111,0	KM2	6
1330956	2252-0159	18,0	32,0	14,0	15,0	111,0	KM2	8
1269821	2252-0162	22,0	40,0	18,0	19,0	138,0	KM3	6
1269822	2252-0161	22,0	40,0	18,0	19,0	138,0	KM3	8
1425469	2252-0163	28,0	50,0	22,0	25,0	173,0	KM4	6
1269824	2252-0164	36,0	60,0	28,0	30,0	188,0	KM4	8
1425470	2252-0165	42,0	72,0	35,0	36,0	229,0	KM5	8
1269827	2252-0166	48,0	85,0	40,0	42,0	240,0	KM5	8
1269829	2252-0167	54,0	95,0	44,0	44,0	251,0	KM5	8

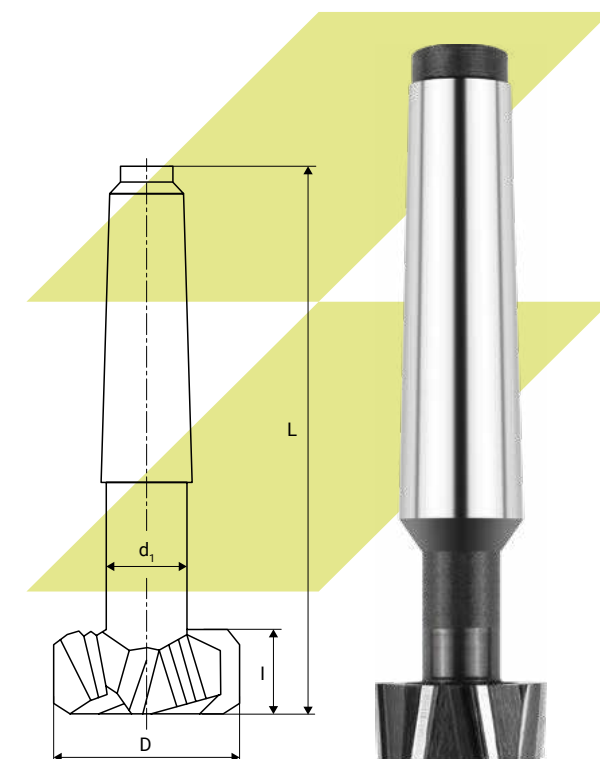

Фрезы с коническим хвостовиком для обработки Т-образных пазов с напаянными твердосплавными пластинами

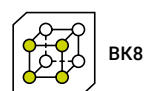
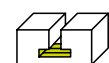

Артикул	Обозначение по ГОСТ	Паз мм	D, мм	I, мм	d ₁ , мм	L, мм	KM	Z, шт
1269816	2252-0021	10,0	18,0	8,0	8,0	82,0	KM1	4
1269819	2252-0004	14,0	25,0	11,0	12,0	103,0	KM2	6
1269820	2252-0005	18,0	32,0	14,0	15,0	111,0	KM2	6
1269823	2252-0006	22,0	40,0	18,0	19,0	138,0	KM3	6
1220069	2252-0007	28,0	50,0	22,0	25,0	173,0	KM4	6
1269825	2252-0008	36,0	60,0	28,0	30,0	188,0	KM4	6
1269826	2252-0009	42,0	72,0	35,0	36,0	229,0	KM5	8
1269828	2252-0011	48,0	85,0	40,0	42,0	240,0	KM5	8
1269830	2252-0012	54,0	95,0	44,0	44,0	251,0	KM5	8

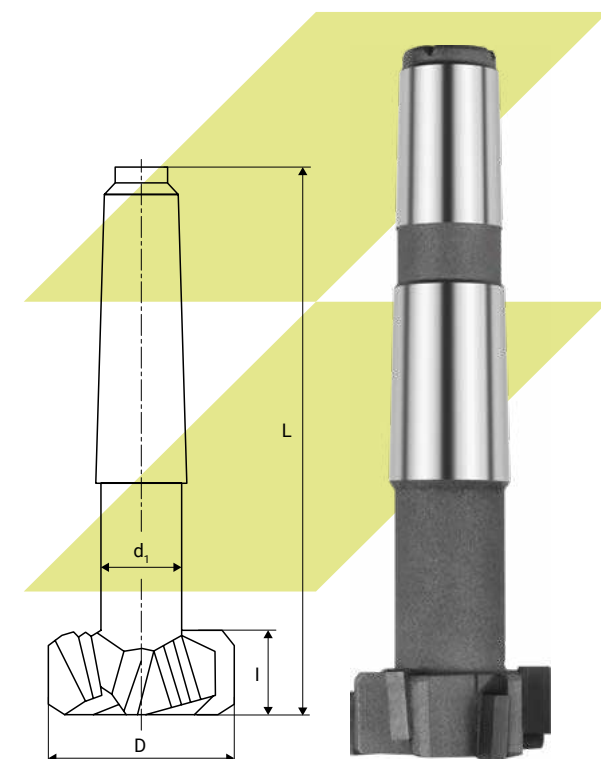

Фрезы дисковые трехсторонние с прямыми зубьями

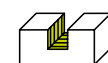

Артикул	Обозначение по ГОСТ	D, мм	I, мм	d, мм	Z, шт
1174811	2240-0351	50,0	4,0	16,0	14
109107	2240-0201	50,0	5,0	16,0	14
109110	2240-0202	50,0	6,0	16,0	14
1174812	2240-0361	50,0	8,0	16,0	14
1582880	2240-0365	50,0	10,0	16,0	14
1582497	2240-0367	63,0	4,0	22,0	16
1144165	2240-0371	63,0	5,0	22,0	16
1256824	2240-0203	63,0	6,0	22,0	16
1418378	2240-0204	63,0	8,0	22,0	16
109152	2240-0206	63,0	12,0	22,0	16
1174816	2240-0387	63,0	14,0	22,0	16
1286967	2240-0391	63,0	16,0	22,0	16
1144166	2240-0393	80,0	5,0	27,0	18
1144167	2240-0395	80,0	6,0	27,0	18
1378466	2240-0397	80,0	7,0	27,0	18
1582498	2240-0207	80,0	8,0	27,0	18
1179351	2240-0208	80,0	10,0	27,0	18
109187	2240-0209	80,0	12,0	27,0	18
109191	2240-0210	80,0	14,0	27,0	18
1377382	2240-0413	80,0	16,0	27,0	18
1265724	2240-0417	80,0	20,0	27,0	18
1144169	2240-0421	100,0	6,0	32,0	20
1144170	2240-0425	100,0	8,0	32,0	18
1377381	2240-0425	100,0	8,0	32,0	20
1533039	2240-0211	100,0	10,0	32,0	20
1184163	2240-0212	100,0	12,0	32,0	20
1419536	2240-0213	100,0	14,0	32,0	20
1272560	2240-0214	100,0	16,0	32,0	20
1174821	2240-0443	100,0	18,0	32,0	20
1582499	2240-0445	100,0	20,0	32,0	20
1149380	2240-0451	100,0	25,0	32,0	20
1582500	2240-0453	125,0	8,0	32,0	22
1582501	2240-0457	125,0	10,0	32,0	22
1144174	2240-0461	125,0	12,0	32,0	22

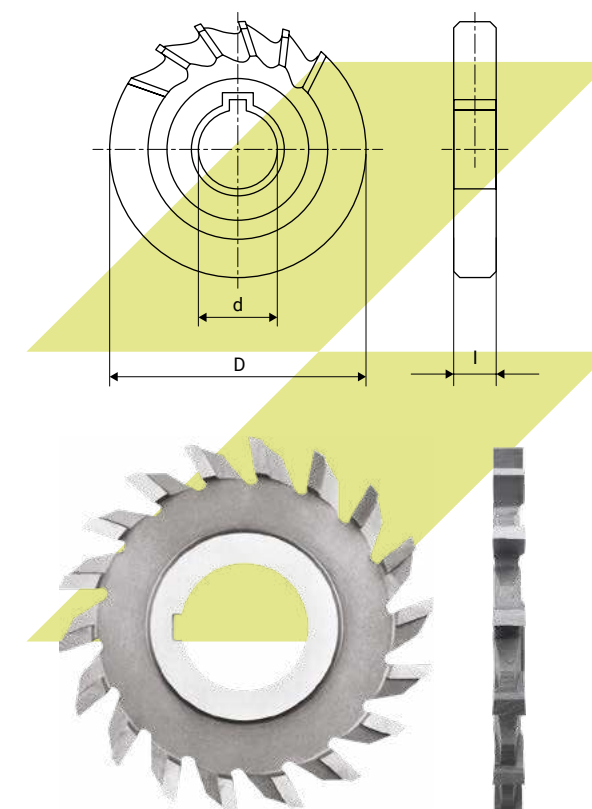

Артикул	Обозначение по ГОСТ	D, мм	l, мм	d, мм	Z, шт
1174824	2240-0463	125,0	14,0	32,0	22
1144175	2240-0465	125,0	16,0	32,0	22
1582502	2240-0467	125,0	18,0	32,0	22
1177801	2240-0467	125,0	18,0	32,0	20
1174825	2240-0471	125,0	20,0	32,0	22
1177802	2240-0473	125,0	22,0	32,0	22
1149381	2240-0475	125,0	25,0	32,0	18
1177803	2240-0475	125,0	25,0	32,0	22
1177804	2240-0477	125,0	28,0	32,0	22
1184123	2240-0551	160,0	10,0	32,0	28
1142562	2240-0551	160,0	10,0	40,0	24

Артикул	Обозначение по ГОСТ	D, мм	l, мм	d, мм	Z, шт
1142563	2240-0552	160,0	12,0	40,0	24
1142564	2240-0553	160,0	14,0	40,0	24
1142565	2240-0554	160,0	16,0	40,0	24
1177805	2240-0555	160,0	18,0	40,0	24
1177806	2240-0556	160,0	20,0	40,0	24
1177807	2240-0557	160,0	22,0	40,0	24
1177808	2240-0558	160,0	25,0	40,0	24
1177809	2240-0559	160,0	28,0	40,0	24
1177810	2240-0561	160,0	32,0	40,0	24
1220855	2240-0562	200,0	12,0	40,0	26
1179361	2240-0564	200,0	16,0	40,0	26

Фрезы дисковые трехсторонние с разнонаправленными зубьями

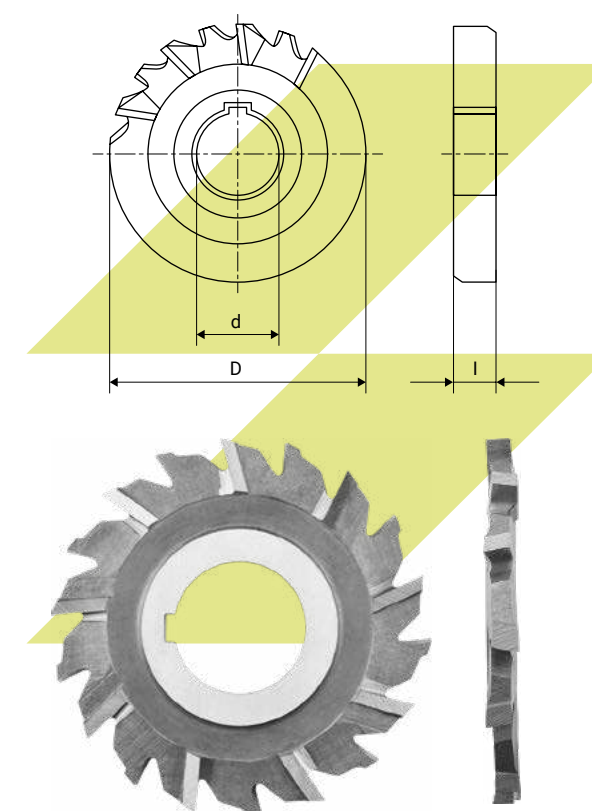

Артикул	Обозначение по ГОСТ	D, мм	l, мм	d, мм	Z, шт
1256825	2240-0601	50,0	4,0	16,0	2x7
1276676	2240-0802	50,0	5,0	16,0	2x6
1256826	2240-0602	50,0	5,0	16,0	2x7
1276677	2240-0803	50,0	6,0	16,0	2x6
1256827	2240-0603	50,0	6,0	16,0	2x7
1256828	2240-0604	50,0	7,0	16,0	2x7
1276678	2240-0805	50,0	8,0	16,0	2x6
1256829	2240-0605	50,0	8,0	16,0	2x7
1276679	2240-0806	50,0	10,0	16,0	2x6
1256830	2240-0606	50,0	10,0	16,0	2x7
1256831	2240-0607	63,0	4,0	22,0	2x8
1174814	2240-0808	63,0	5,0	22,0	2x6
1256832	2240-0608	63,0	5,0	22,0	2x8
1174815	2240-0151	63,0	6,0	22,0	2x6
1256833	2240-0101	63,0	6,0	22,0	2x8
1276680	2240-0809	63,0	7,0	22,0	2x6
1256834	2240-0609	63,0	7,0	22,0	2x8
109140	2240-0152	63,0	8,0	22,0	2x6
1256835	2240-0102	63,0	8,0	22,0	2x8
1276681	2240-0153	63,0	10,0	22,0	2x6
1256836	2240-0103	63,0	10,0	22,0	2x8
109158	2240-0154	63,0	12,0	22,0	2x6
1256837	2240-0104	63,0	12,0	22,0	2x8
1240462	2240-0259	63,0	14,0	22,0	2x6
1256838	2240-0251	63,0	14,0	22,0	2x8
1174817	2240-0811	80,0	5,0	27,0	2x7
1256840	2240-0611	80,0	5,0	27,0	2x9
1174818	2240-0812	80,0	6,0	27,0	2x7
1256841	2240-0612	80,0	6,0	27,0	2x9
1256842	2240-0613	80,0	7,0	27,0	2x9
1179350	2240-0155	80,0	8,0	27,0	2x7
1256843	2240-0105	80,0	8,0	27,0	2x9
1289578	2240-0156	80,0	10,0	27,0	2x7
1256844	2240-0106	80,0	10,0	27,0	2x9

Артикул	Обозначение по ГОСТ	D, мм	l, мм	d, мм	Z, шт
109189	2240-0157	80,0	12,0	27,0	2x7
1256845	2240-0107	80,0	12,0	27,0	2x9
109193	2240-0158	80,0	14,0	27,0	2x7
1256846	2240-0108	80,0	14,0	27,0	2x9
1478440	2240-0159	80,0	16,0	27,0	2x7
1256847	2240-0109	80,0	16,0	27,0	2x9
1256848	2240-0253	80,0	18,0	27,0	2x9
1256849	2240-0254	80,0	20,0	27,0	2x9
1256850	2240-0614	100,0	6,0	32,0	2x10
1174819	2240-0814	100,0	6,0	32,0	2x7
1256851	2240-0615	100,0	7,0	32,0	2x10
1256852	2240-0616	100,0	8,0	32,0	2x10
1174820	2240-0816	100,0	8,0	32,0	2x7
1256853	2240-0110	100,0	10,0	32,0	2x10
1179352	2240-0160	100,0	10,0	32,0	2x7
1256854	2240-0111	100,0	12,0	32,0	2x10
1256855	2240-0112	100,0	14,0	32,0	2x10
1256856	2240-0113	100,0	16,0	32,0	2x10
1256857	2240-0114	100,0	18,0	32,0	2x10
1177800	2240-0164	100,0	18,0	32,0	2x7

Артикул	Обозначение по ГОСТ	D, мм	l, мм	d, мм	Z, шт
1256858	2240-0115	100,0	20,0	32,0	2x10
1256859	2240-0255	100,0	22,0	32,0	2x10
1256860	2240-0256	100,0	25,0	32,0	2x10
1256861	2240-0617	125,0	8,0	32,0	2x11
1256862	2240-0618	125,0	10,0	32,0	2x11
1174823	2240-0818	125,0	10,0	32,0	2x9
1253278	2240-0116	125,0	12,0	32,0	2x11
1179354	2240-0166	125,0	12,0	32,0	2x9
1256864	2240-0117	125,0	14,0	32,0	2x11
1179355	2240-0167	125,0	14,0	32,0	2x9
1256865	2240-0118	125,0	16,0	32,0	2x11
1179356	2240-0168	125,0	16,0	32,0	2x9
1256866	2240-0119	125,0	18,0	32,0	2x11
1179358	2240-0169	125,0	18,0	32,0	2x9
1256867	2240-0120	125,0	20,0	32,0	2x11
1179359	2240-0170	125,0	20,0	32,0	2x9
1256868	2240-0121	125,0	22,0	32,0	2x11
1256869	2240-0257	125,0	25,0	32,0	2x11
1179360	2240-0266	125,0	25,0	32,0	2x9
1256870	2240-0258	125,0	28,0	32,0	2x11

Фрезы дисковые трехсторонние со впresованными ножами из быстрорежущей стали



Артикул	D, мм	l, мм	d, мм	Z, шт
109261	100,0	18,0	27,0	14
115990	100,0	28,0	27,0	14
109270	125,0	12,0	32,0	16
109271	125,0	32,0	32,0	16
109276	160,0	22,0	40,0	18
1111029	200,0	12,0	50,0	24
109281	200,0	20,0	50,0	24

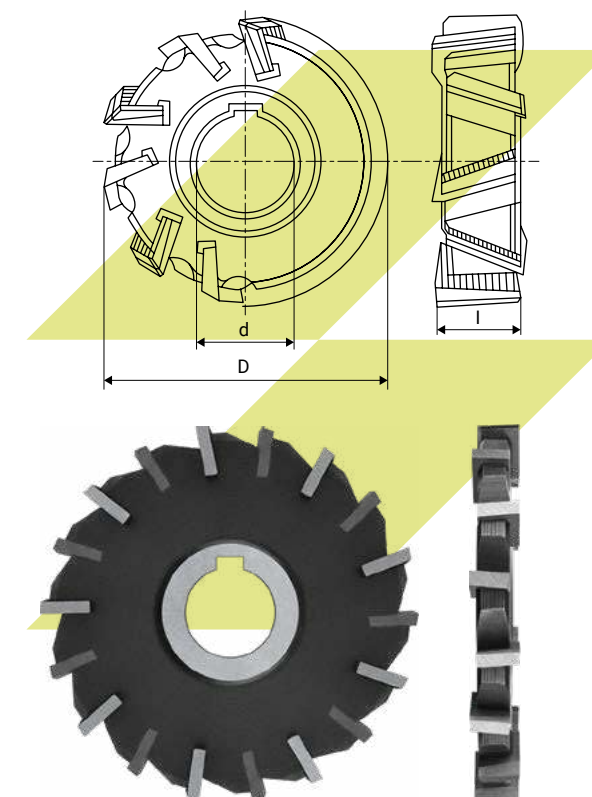

Фрезы дисковые трехсторонние со сменными ножами



Артикул	D, мм	l, мм	d, мм	Z, шт
109289	100,0	14,0	27,0	12
109290	100,0	18,0	27,0	12
109292	100,0	22,0	27,0	10
109294	100,0	28,0	27,0	10
114757	125,0	12,0	32,0	16
114944	125,0	16,0	32,0	14
109302	125,0	20,0	32,0	12
109305	125,0	25,0	32,0	12
109306	125,0	32,0	32,0	10
109310	160,0	18,0	40,0	18
109311	160,0	22,0	40,0	18
109313	160,0	36,0	40,0	16
109316	200,0	16,0	50,0	20
1103183	200,0	25,0	50,0	20
109320	200,0	32,0	50,0	18

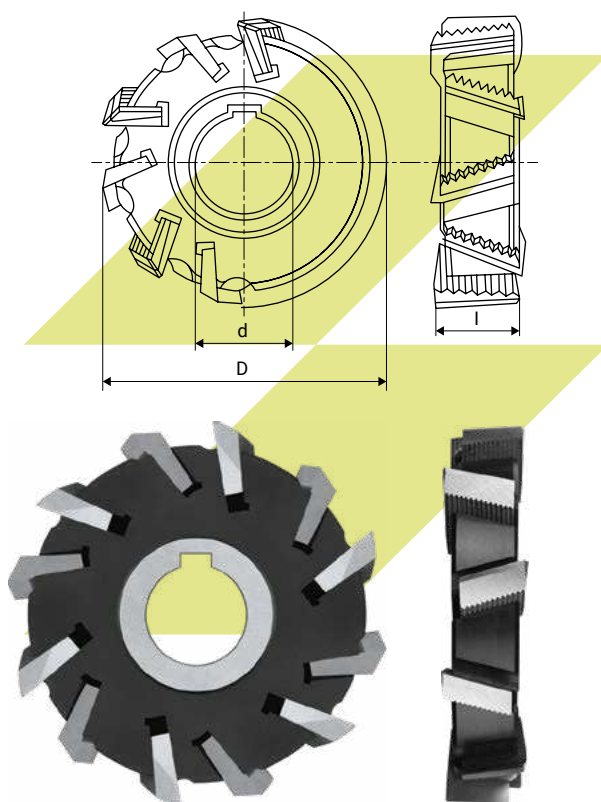

Сменные ножи для фрез дисковых трехсторонних

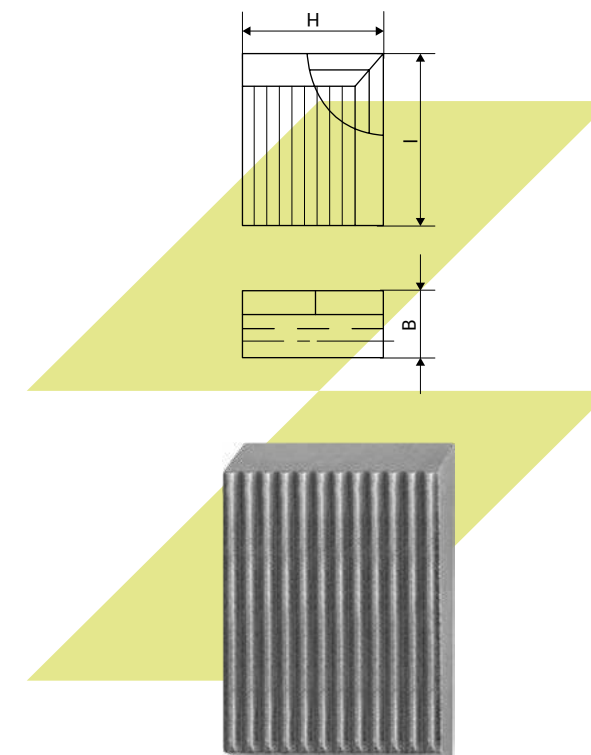

Артикул	Обозначение по ГОСТ	H, мм	b, мм	l, мм	α°	D=100, мм	D=125, мм	D=160, мм	D=180, мм	D=200, мм	D=224, мм	D=250, мм	D=315, мм
103885	2020-0161	11,0	4,74	23,8	7,5	B12.Z8	B12.Z10	B12.Z10	B12.Z12	B12.Z12	B12.Z14	—	—
103887	2020-0162	11,0	4,74	23,8	7,5	B12.Z8	B12.Z10	B12.Z10	B12.Z12	B12.Z12	B12.Z14	—	—
103889	2020-0163	13,0	4,74	23,8	7,5	B14.Z8	—	—	—	—	—	—	—
103892	2020-0164	13,0	4,74	23,8	7,5	B14.Z8	—	—	—	—	—	—	—
103895	2020-0165	15,0	4,74	23,8	7,5	B16(18).Z8	B16(18).Z10	—	—	—	—	—	—
103897	2020-0166	15,0	4,74	23,8	7,5	B16(18).Z8	B16(18).Z10	—	—	—	—	—	—
103900	2020-0167	15,0	5,73	28,3	7,5	—	—	B16.Z10	B16.Z12	B16.Z12	B16.Z14	B16.Z16	—
103902	2020-0168	15,0	5,73	28,3	7,5	—	—	B16.Z10	B16.Z12	B16.Z12	B16.Z14	B16.Z16	—
103871	2020-0021	18,5	5,73	28,3	15,0	B20.Z8	B20.Z10	B20(22).Z10	B20.Z12	B20.Z12	B20(22).Z14	B20.Z16	B20.Z20
103873	2020-0022	18,5	5,73	28,3	15,0	B20.Z8	B20.Z10	B20(22).Z10	B20.Z12	B20.Z12	B20(22).Z14	B20.Z16	B20.Z20
103875	2020-0023	22,5	5,73	28,3	15,0	—	B25.Z10	—	B25.Z12	B25.Z12	—	—	B25.Z20
103879	2020-0024	22,5	5,73	28,3	15,0	—	B25.Z10	—	B25.Z12	B25.Z12	—	—	B25.Z20

Артикул	Обозначение по ГОСТ	H, мм	b, мм	l, мм	α° , мм	D=100, мм	D=125, мм	D=160, мм	D=180, мм	D=200, мм	D=224, мм	D=250, мм	D=315, мм
103882	2020-0026	25,5	7,72	33,8	15,0	—	—	—	—	—	—	—	B32.Z20
103903	2020-0169	26,5	5,73	28,3	15,0	—	—	—	—	—	B28.Z14	B28.Z16	—
103904	2020-0170	26,5	5,73	28,3	15,0	—	—	—	—	—	B28.Z14	B28.Z16	—

Фрезы дисковые трехсторонние со вставными ножами, оснащенными твердым сплавом

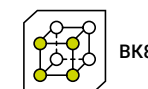

Артикул	Обозначение по ГОСТ	D, мм	l, мм	d, мм	Z, шт
1128510	2241-0008	125,0	12,0	40,0	10
1129674	2241-0010	125,0	16,0	40,0	10
1129677	2241-0020	160,0	22,0	50,0	12
1103484	2241-0033	200,0	12,0	50,0	14

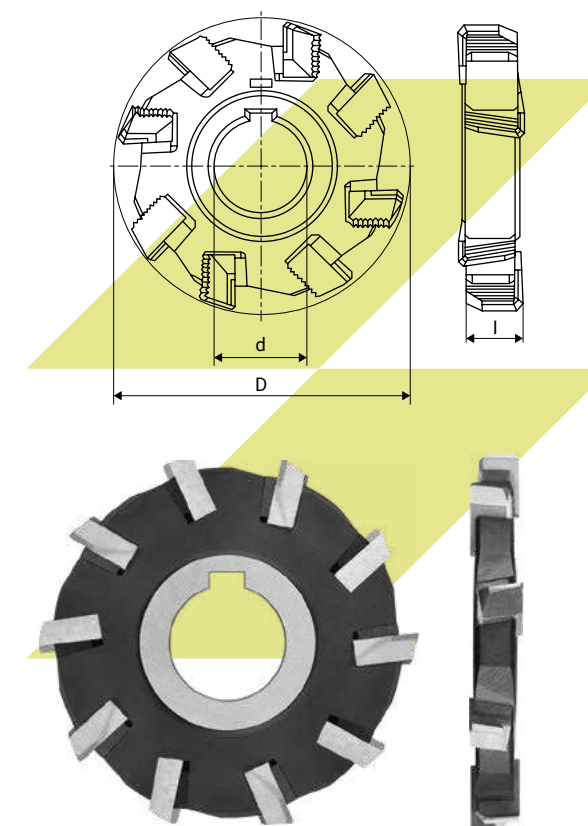

Ножи, оснащенные твердым сплавом, для трехсторонних дисковых фрез

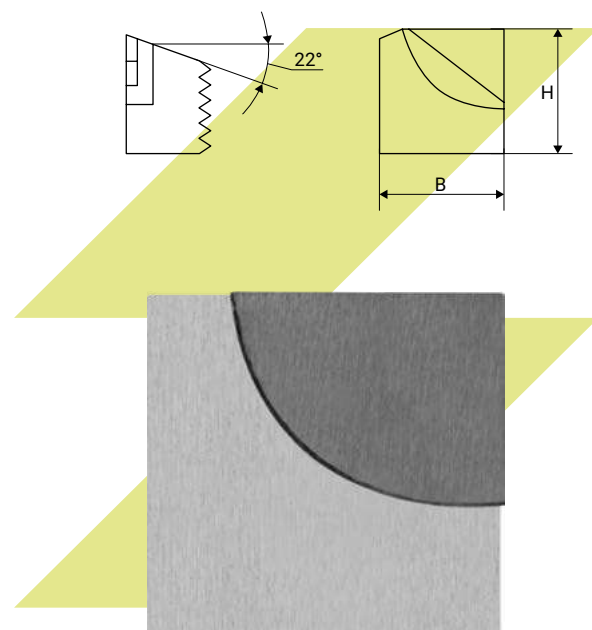

Артикул	Обозначение по ГОСТ	H, мм	B, мм	I, мм	D=100, мм	D=125, мм	D=160, мм	D=180, мм	D=200, мм	D=224, мм	D=250, мм	D=315, мм
103918	2026-0021	12,0	8,3	20,0	B14.Z8	—	—	—	—	—	—	—
103920	2026-0022	12,0	8,3	20,0	B14.Z8	—	—	—	—	—	—	—
103922	2026-0025	20,0	10,3	20,0	B22.Z8	—	—	—	—	—	—	—
103923	2026-0026	20,0	10,3	20,0	B22.Z8	—	—	—	—	—	—	—
103924	2026-0027	11,0	8,3	22,0	—	B12.Z10	—	—	—	—	—	—
103927	2026-0028	11,0	8,3	22,0	—	B12.Z10	—	—	—	—	—	—
103929	2026-0029	14,0	8,3	22,0	—	B16.Z10	—	—	—	—	—	—
103931	2026-0030	14,0	8,3	22,0	—	B16.Z10	—	—	—	—	—	—
103936	2026-0032	18,0	10,3	22,0	—	B20.Z10	—	—	—	—	—	—
103939	2026-0033	22,0	12,3	22,0	—	B25.Z10	—	—	—	—	—	—
103940	2026-0034	22,0	12,3	22,0	—	B25.Z10	—	—	—	—	—	—
103942	2026-0035	12,0	10,3	25,0	—	—	B14.Z12	—	—	—	—	—

Артикул	Обозначение по ГОСТ	H, мм	B, мм	I, мм	D=100, мм	D=125, мм	D=160, мм	D=180, мм	D=200, мм	D=224, мм	D=250, мм	D=315, мм
103944	2026-0036	12,0	10,3	25,0	—	—	B14.Z12	—	—	—	—	—
103946	2026-0037	16,0	10,3	25,0	—	—	B18.Z12	—	—	—	—	—
103949	2026-0038	16,0	10,3	25,0	—	—	B18.Z12	—	—	—	—	—
103954	2026-0040	20,0	10,3	25,0	—	—	B22.Z12	—	—	—	—	—
103956	2026-0041	25,0	12,3	25,0	—	—	B28.Z12	—	—	—	—	—
103958	2026-0042	25,0	12,3	25,0	—	—	B28.Z12	—	—	—	—	—
103960	2026-0043	11,0	10,3	28,0	—	—	—	B12.Z14	B12.Z14	—	B12.Z14	—
103962	2026-0044	11,0	10,3	28,0	—	—	—	B12.Z14	B12.Z14	—	B12.Z14	—
103964	2026-0045	14,0	10,3	28,0	—	—	—	B12.Z14	B16.Z14	—	B16.Z14	—
103967	2026-0046	14,0	10,3	28,0	—	—	—	B12.Z14	B16.Z14	—	B16.Z14	—
103970	2026-0047	18,0	10,3	28,0	—	—	—	B12.Z14	B20.Z14	—	B20.Z14	—
103973	2026-0048	18,0	10,3	28,0	—	—	—	B12.Z14	B20.Z14	—	B20.Z14	—
103976	2026-0049	22,0	12,3	28,0	—	—	—	B12.Z12	B25.Z12	—	B25.Z14	—
103979	2026-0050	22,0	12,3	28,0	—	—	—	B12.Z12	B25.Z12	—	B25.Z14	—
103980	2026-0051	28,0	14,3	28,0	—	—	—	B12.Z12	B32.Z12	—	B32.Z14	—
1236256	2026-0058	20,0	12,3	30,0	—	—	—	—	—	B22.Z16	—	B22.Z16

Ножи, оснащенные твердым сплавом, для трехсторонних дисковых фрез

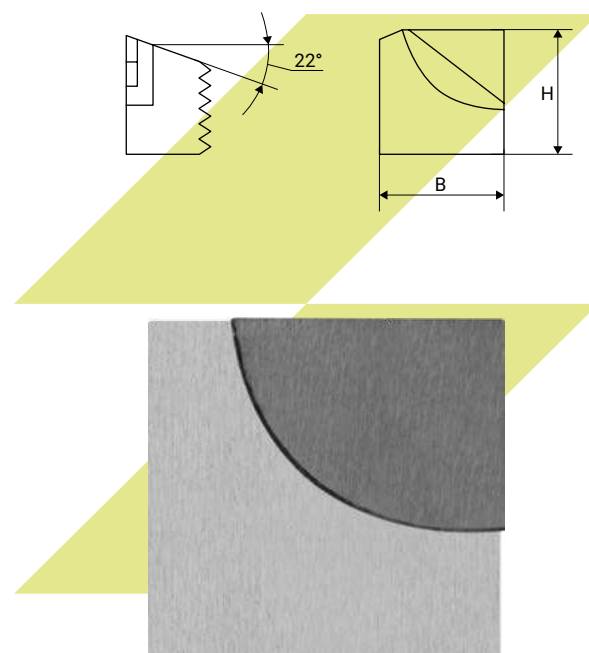

Артикул	Обозначение по ГОСТ	H, мм	B, мм	l, мм	D=100, мм	D=125, мм	D=160, мм	D=180, мм	D=200, мм	D=224, мм	D=250, мм	D=315, мм
103919	2026-0021	12,0	8,3	20,0	B14.Z8	—	—	—	—	—	—	—
1236253	2026-0025	20,0	10,3	20,0	B22.Z8	—	—	—	—	—	—	—
1236252	2026-0026	20,0	10,3	20,0	B22.Z8	—	—	—	—	—	—	—
103926	2026-0027	11,0	8,3	22,0	—	B12.Z10	—	—	—	—	—	—
1103680	2026-0029	14,0	8,3	22,0	—	B16.Z10	—	—	—	—	—	—
103933	2026-0030	14,0	8,3	22,0	—	B16.Z10	—	—	—	—	—	—
103938	2026-0032	18,0	10,3	22,0	—	B20.Z10	—	—	—	—	—	—
103948	2026-0037	16,0	10,3	25,0	—	—	B18.Z12	—	—	—	—	—
103953	2026-0039	20,0	10,3	25,0	—	—	B22.Z12	—	—	—	—	—
103955	2026-0040	20,0	10,3	25,0	—	—	B22.Z12	—	—	—	—	—
1182614	2026-0043	11,0	10,3	28,0	—	—	—	B12.Z14	B12.Z14	—	B12.Z14	—
1182615	2026-0044	11,0	10,3	28,0	—	—	—	B12.Z14	B12.Z14	—	B12.Z14	—

Артикул	Обозначение по ГОСТ	H, мм	B, мм	l, мм	D=100, мм	D=125, мм	D=160, мм	D=180, мм	D=200, мм	D=224, мм	D=250, мм	D=315, мм
103966	2026-0045	14,0	10,3	28,0	—	—	—	B12.Z14	B16.Z14	—	B16.Z14	—
103969	2026-0046	14,0	10,3	28,0	—	—	—	B12.Z14	B16.Z14	—	B16.Z14	—

Фрезы дисковые пазовые

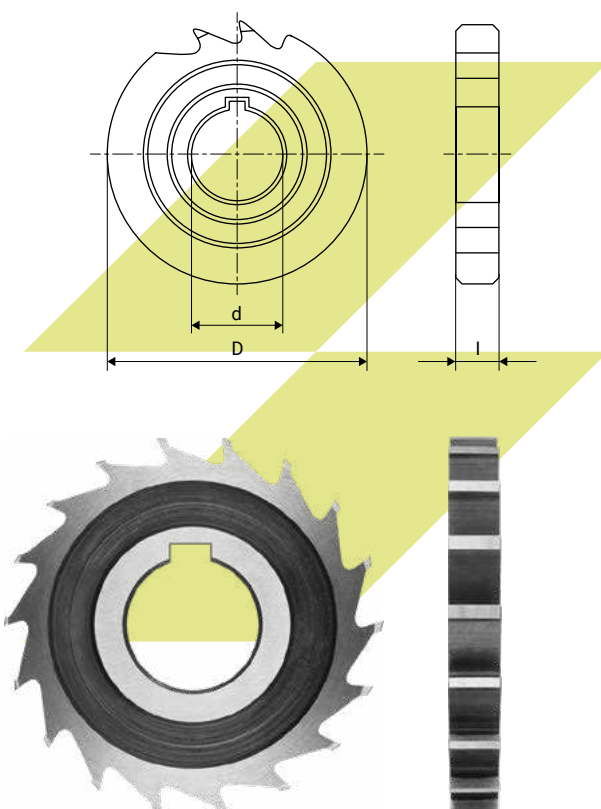

Артикул	Обозначение по ГОСТ	D, мм	l, мм	d, мм	Z, шт
1105634	2250-0001	50,0	3,0	16,0	14
109896	2250-0002	50,0	4,0	16,0	14
109899	2250-0003	50,0	5,0	16,0	14
109901	2250-0004	50,0	6,0	16,0	14
1243899	2250-0101	50,0	8,0	16,0	14
1243900	2250-0102	50,0	10,0	16,0	14
1243901	2250-0103	63,0	4,0	22,0	16
1583518	2250-0005	63,0	5,0	22,0	16
1583519	2250-0006	63,0	6,0	22,0	16
115742	2250-0007	63,0	8,0	22,0	16
1243902	2250-0104	63,0	10,0	22,0	16
1243903	2250-0105	63,0	12,0	22,0	16
1243904	2250-0106	63,0	14,0	22,0	16
1243905	2250-0107	80,0	5,0	27,0	18
1243906	2250-0108	80,0	6,0	27,0	18
1260627	2250-0008	80,0	8,0	27,0	18
109917	2250-0009	80,0	10,0	27,0	18
109921	2250-0010	80,0	12,0	27,0	18
1243907	2250-0109	80,0	14,0	27,0	18
1243908	2250-0111	80,0	16,0	27,0	18
1243909	2250-0112	80,0	18,0	27,0	18
1243910	2250-0113	100,0	6,0	32,0	20
1243911	2250-0114	100,0	8,0	32,0	20
1243914	2250-0011	100,0	10,0	32,0	20
114815	2250-0012	100,0	12,0	32,0	20
109931	2250-0013	100,0	14,0	32,0	20
109933	2250-0014	100,0	16,0	32,0	20
1243912	2250-0115	100,0	18,0	32,0	20
1243913	2250-0116	100,0	20,0	32,0	20
1243915	2250-0015	125,0	8,0	32,0	22
1243916	2250-0119	125,0	10,0	32,0	22
1243917	2250-0016	125,0	12,0	32,0	22

Фрезы дисковые пазовые затылованные

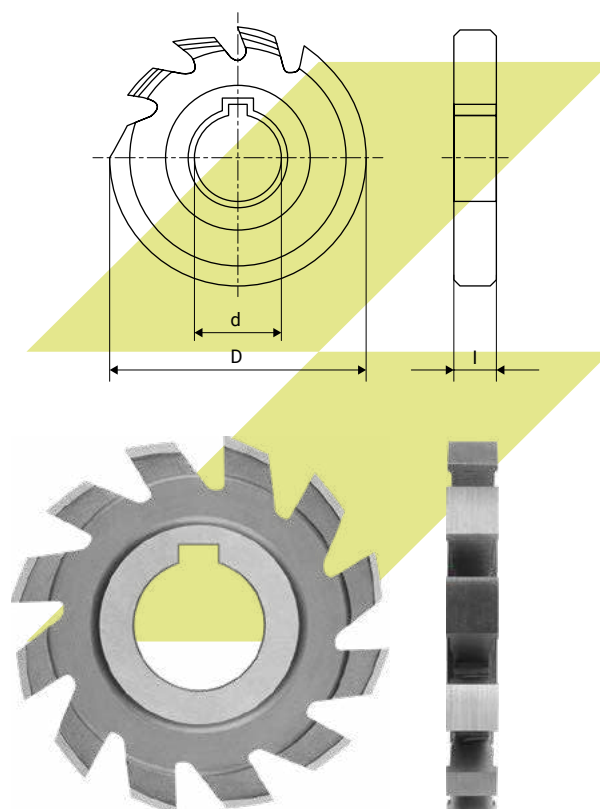
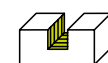

Артикул	Обозначение по ГОСТ	D, мм	l, мм	d, мм	Z, шт
116111	2250-0051	50,0	4,0	16,0	12
1105493	2250-0052	50,0	5,0	16,0	12
109936	2250-0053	50,0	6,0	16,0	12
109940	2250-0054	63,0	5,0	22,0	12
109943	2250-0055	63,0	6,0	22,0	12
109945	2250-0056	63,0	7,0	22,0	12
1138289	2250-0057	63,0	8,0	22,0	12
1108457	2250-0058	80,0	7,0	27,0	12
115952	2250-0059	80,0	8,0	27,0	12
109959	2250-0060	80,0	10,0	27,0	12
109961	2250-0061	80,0	12,0	27,0	12
109967	2250-0062	100,0	10,0	32,0	14
109969	2250-0063	100,0	12,0	32,0	14
109974	2250-0064	100,0	14,0	32,0	14
1107954	2250-0065	100,0	16,0	32,0	14

Фрезы одноугловые

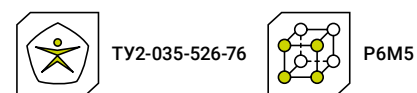
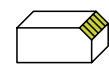

Артикул		α°	D, мм	l, мм	d, мм	Z, шт
1128043		45	40,0	8,0	16,0	20
111853		50	40,0	8,0	16,0	20
111873		50	63,0	12,0	22,0	22
1150818		70	40,0	10,0	16,0	20
1174939		70	50,0	12,0	16,0	20
1174934		75	40,0	12,0	16,0	20
1326443		75	50,0	16,0	16,0	20
1174937		80	45,0	13,0	16,0	20
1174940		80	50,0	16,0	16,0	20
111878		80	63,0	20,0	22,0	22
111859		85	45,0	13,0	16,0	20
111880		85	63,0	20,0	22,0	22
111855		90	40,0	12,0	16,0	20
111881		90	63,0	20,0	22,0	22
116476		105	63,0	14,0	22,0	22

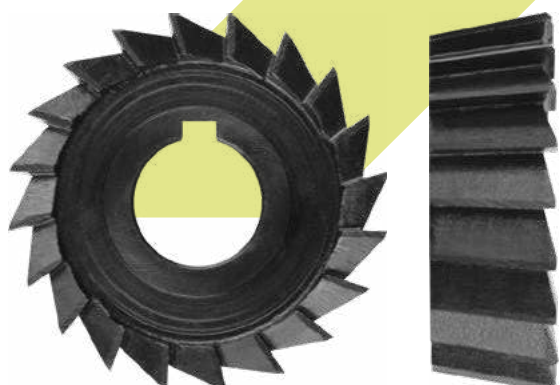
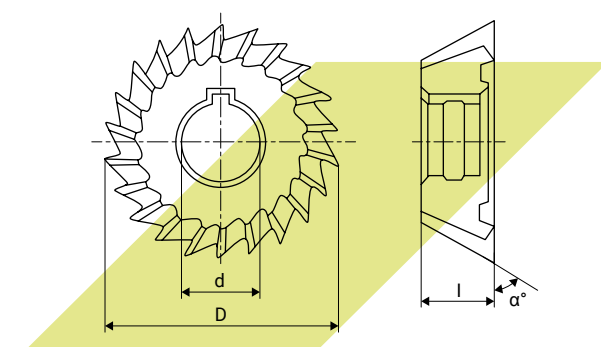

Фрезы угловые двусторонние

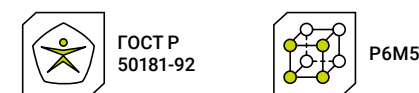
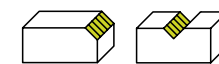

Артикул		Обозначение по ГОСТ	α°	D, мм	l, мм	d, мм	Z, шт
1185618		2292-0001	45	50,0	8,0	16,0	20
1185621		2292-0004	45	63,0	10,0	22,0	20
1185624		2292-0007	45	80,0	12,0	27,0	22
1185627		2292-0011	45	100,0	18,0	32,0	24
1425297		—	60	50,0	8,0	16,0	20
1185619		2292-0002	60	50,0	10,0	16,0	20
1185622		2292-0005	60	63,0	14,0	22,0	20
1185625		2292-0008	60	80,0	18,0	27,0	22
1185628		2292-0012	60	100,0	25,0	32,0	24
1185620		2292-0003	90	50,0	14,0	16,0	20
1185623		2292-0006	90	63,0	20,0	22,0	20
1185626		2292-0009	90	80,0	22,0	27,0	22
1185629		2292-0013	90	100,0	32,0	32,0	24

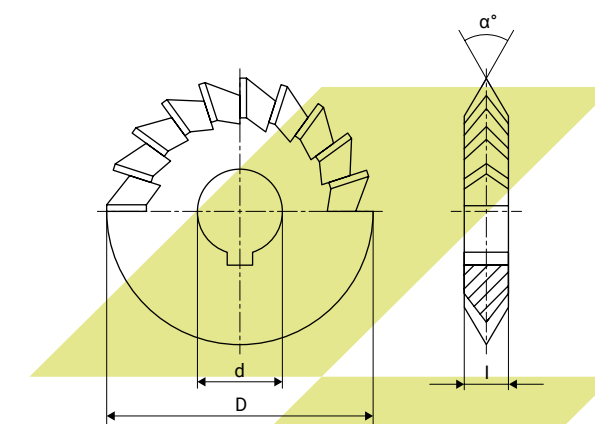

Фрезы фасонные полукруглые выпуклые

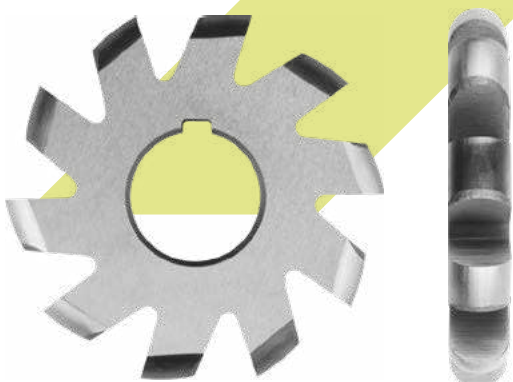
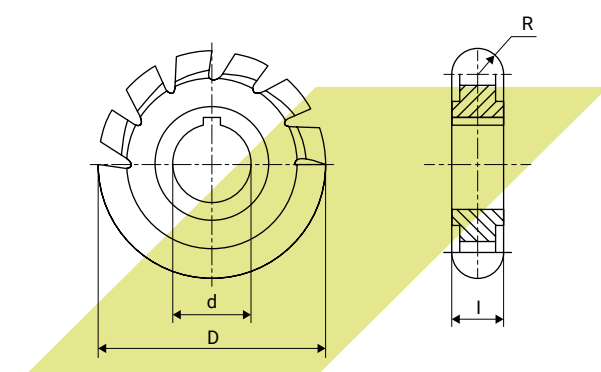
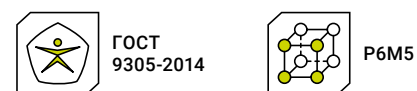
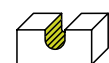

Артикул	Обозначение по ГОСТ	D, мм	R, мм	l, мм	d, мм	Z, шт
1261607	2262-0052	50,0	1,0	2,0	16,0	14
1261608	2262-0053	50,0	1,25	2,5	16,0	14
111997	2262-0165	50,0	1,6	3,2	22,0	14
112001	2262-0052	50,0	2,0	4,0	22,0	14
112005	—	50,0	2,5	5,0	22,0	14
1479840	2262-0054	63,0	3,0	6,0	22,0	10
1261609	2262-0303	63,0	3,15	6,3	22,0	10
119507	2262-0055	63,0	4,0	8,0	22,0	10
1261610	2262-0304	63,0	5,0	10,0	22,0	10
112023	2262-0059	80,0	4,0	8,0	27,0	10
112026	—	80,0	5,0	10,0	27,0	10
1261611	2262-0058	80,0	6,0	12,0	27,0	10
1261612	2262-0305	80,0	6,3	12,6	27,0	10
1261613	2262-0167	80,0	7,0	14,0	27,0	10
1343153	2262-0059	80,0	8,0	16,0	27,0	10
1130995	—	100,0	6,5	17,0	27,0	15
112039	—	100,0	8,0	16,0	32,0	10
1261614	2262-0168	100,0	9,0	18,0	32,0	10
112043	2262-0061	100,0	10,0	20,0	32,0	10
1343154	2262-0169	100,0	11,0	22,0	32,0	10
112049	2262-0062	100,0	12,0	24,0	32,0	10
112055	—	125,0	12,0	24,0	32,0	10
1425779	2262-0170	125,0	14,0	28,0	32,0	10
112056	2262-0064	125,0	16,0	32,0	32,0	10
1377923	2262-0171	125,0	18,0	36,0	32,0	10
1261615	2262-0172	125,0	20,0	40,0	32,0	10
1377924	2262-0173	130,0	25,0	50,0	40,0	10

Фрезы фасонные полукруглые вогнутые

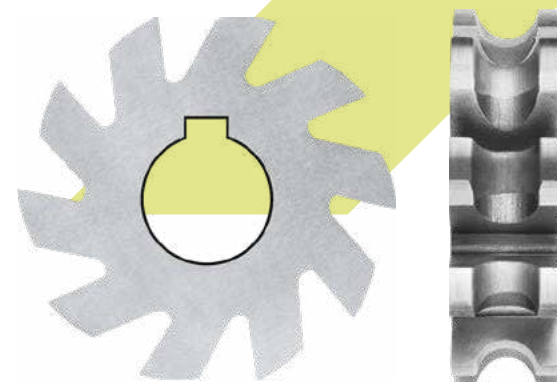
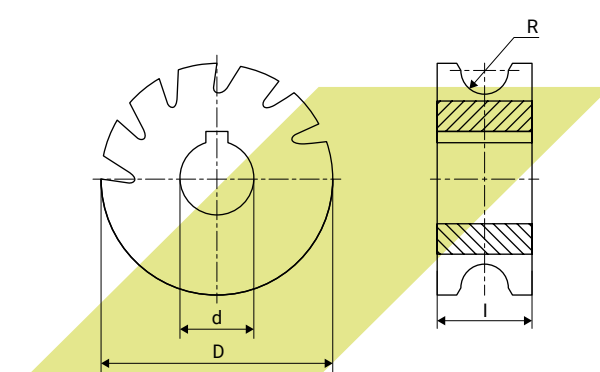

Артикул	Обозначение по ГОСТ	D, мм	R, мм	l, мм	d, мм	Z, шт
1261602	2262-0351	50,0	1,0	6,0	16,0	12
1261603	2262-0352	50,0	1,25	6,0	16,0	12
111940	2262-0115	50,0	1,6	7,0	22,0	14
111946	2262-0102	50,0	2,0	8,0	22,0	14
111950	—	50,0	2,5	10,0	22,0	14
111960	2262-0103	63,0	2,5	10,0	22,0	12
111965	2262-0104	63,0	3,0	12,0	22,0	12
1377918	2262-0353	63,0	3,15	12,0	22,0	12
111970	2262-0105	63,0	4,0	14,0	22,0	12
1261604	2262-0354	63,0	5,0	20,0	22,0	12
111975	—	80,0	4,0	14,0	27,0	10
111978	—	80,0	5,0	18,0	27,0	10
111980	2262-0108	80,0	6,0	22,0	27,0	10
1261605	2262-0355	80,0	6,3	24,0	27,0	10
1343151	—	80,0	7,0	32,0	27,0	10
111985	2262-0109	80,0	8,0	28,0	27,0	10
111989	—	100,0	8,0	28,0	32,0	10
1343152	2262-0118	100,0	9,0	36,0	32,0	10
111991	2262-0111	100,0	10,0	35,0	32,0	10
1261606	2262-0119	100,0	11,0	40,0	32,0	10
119091	2262-0112	100,0	12,0	40,0	32,0	10
1377919	2262-0356	100,0	12,5	40,0	32,0	10
1337834	—	100,0	14,0	48,0	32,0	10
111993	—	125	12,0	40,0	32,0	10
1377920	2262-0121	125	14,0	48,0	32,0	10
1418604	2262-0114	125	16,0	48,0	32,0	10
1377921	2262-0122	125	18,0	55,0	32,0	10
1377922	2262-0123	125	20,0	60,0	32,0	10

Фрезы торцовые насадные мелкозубые со вставными ножами, оснащенные пластинами из твердого сплава



Артикул	Обозначение по ГОСТ	D, мм	l, мм	d, мм	Нож	Z, шт
111817	2214-0153	100,0	42,0	32,0	2021-0013	10
111841	2214-0159	200,0	47,0	50,0	2021-0015	20
1136171	2214-0161	250,0	50,0	60,0	2021-0015	24

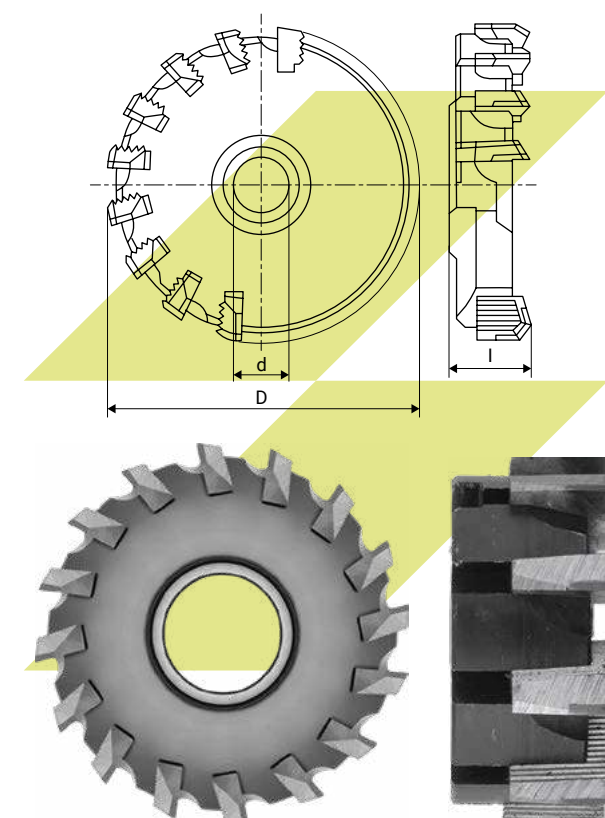

Нож клиновидный рифленый, оснащенный твердосплавными пластинами

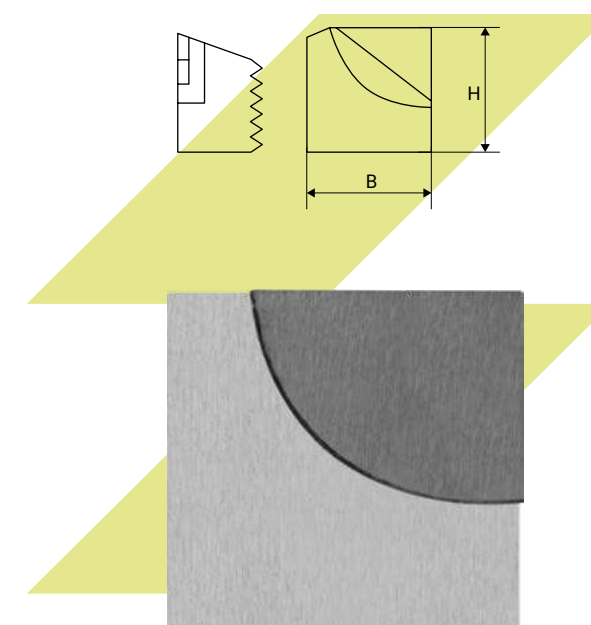
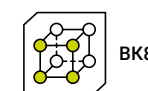

Артикул	Обозначение по ГОСТ	H, мм	B, мм	l, мм	D=100, мм	D=125, мм	D=160, мм	D=200, мм	D=250, мм	D=315, мм	D=400, мм
103910	2021-0013	22,5	8,51	28,8	Z10	Z12	—	—	—	—	—
103914	2021-0017	45,8	9,24	31,3	—	—	Z16	Z20	Z24	Z30	Z36

Фрезы торцовые насадные со вставными ножами, оснащенными пластинами из твердого сплава



Артикул	Обозначение по ГОСТ	D, мм	l, мм	d, мм	Нож	Z, шт
111816	2214-0001	100,0	50,0	32,0	2020-0001	8
115878	2214-0003	125,0	55,0	40,0	2020-0003	8
1102746	2214-0005	160,0	60,0	50,0	2020-0005	10
111844	2214-0007	200,0	60,0	50,0	2020-0007	12
111850	2214-0301	250,0	75,0	60,0	2020-0005	14

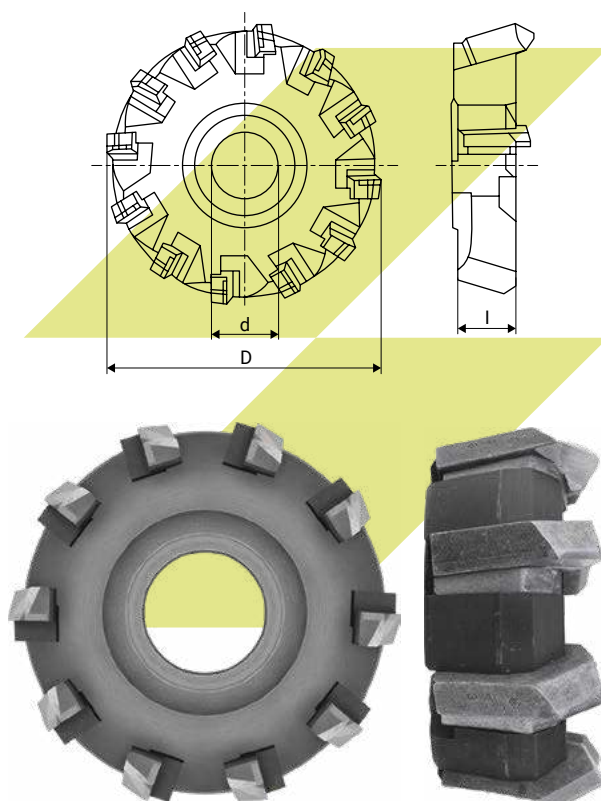

Ножи вставные для фрез торцовых насадных из твёрдого сплава

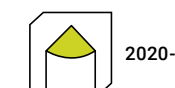

Артикул	Обозначение по ГОСТ	H, мм	B, мм	L, мм
103856	2020-0001	18,0	12,0	42,0
103862	2020-0003	20,0	14,0	50,0
103866	2020-0005	28,0	16,0	70,0
103869	2020-0007	32,0	18,0	80,0

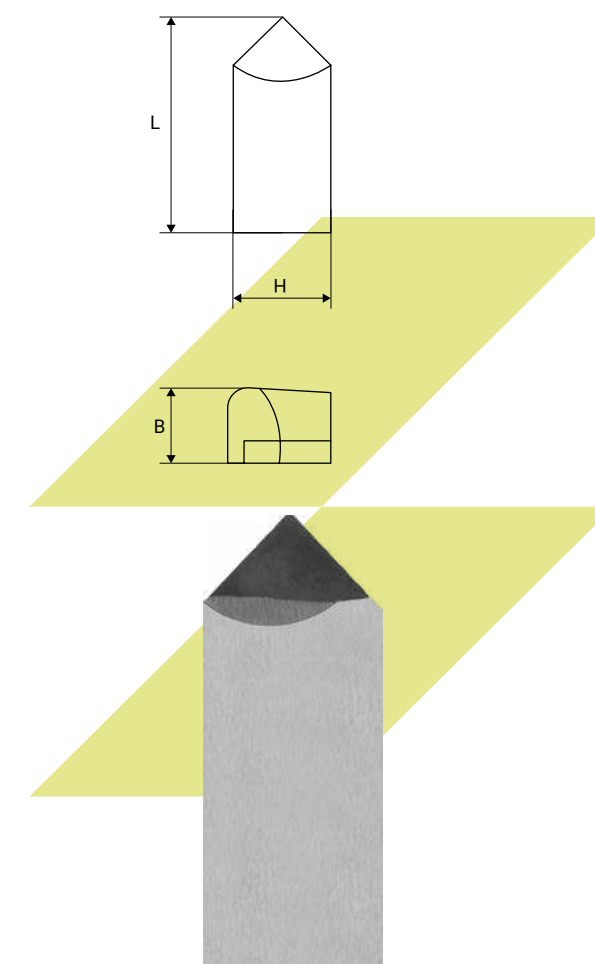

Ножи вставные для фрез торцовых насадных из твёрдого сплава



Артикул	Обозначение по ГОСТ	H, мм	B, мм	L, мм
103857	2020-0003	20,0	14,0	50,0
103865	2020-0005	28,0	16,0	70,0

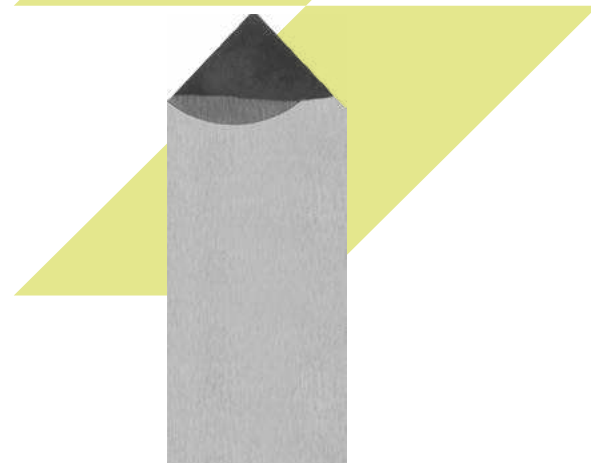
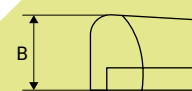
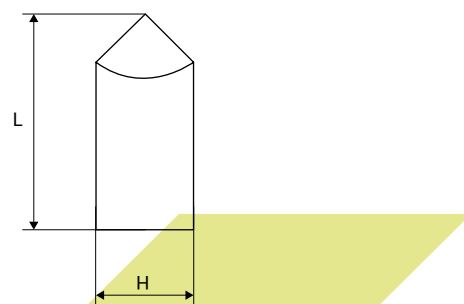

Ножи вставные для фрез торцовых насадных из твёрдого сплава

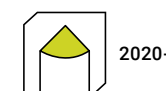
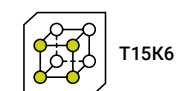

Артикул	Обозначение по ГОСТ	H, мм	B, мм	L, мм
103861	2020-0003	20,0	14,0	50,0
1109145	2020-0005	28,0	16,0	70,0

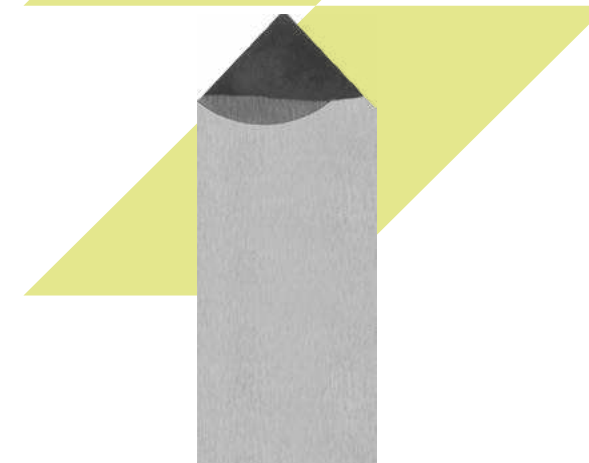
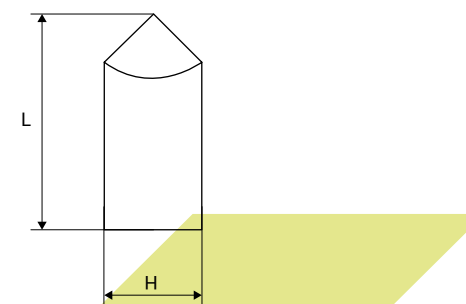

Фрезы торцовые с механическим креплением многогранных пластин



Артикул	Обозначение по ГОСТ	D, мм	l, мм	d, мм	Z, шт
111748	2214-0391	100,0	50,0	32,0	8
111755	2214-0273	125,0	63,0	40,0	8
111767	2214-0544	160,0	63,0	50,0	10
111775	2214-0277	200,0	63,0	50,0	12

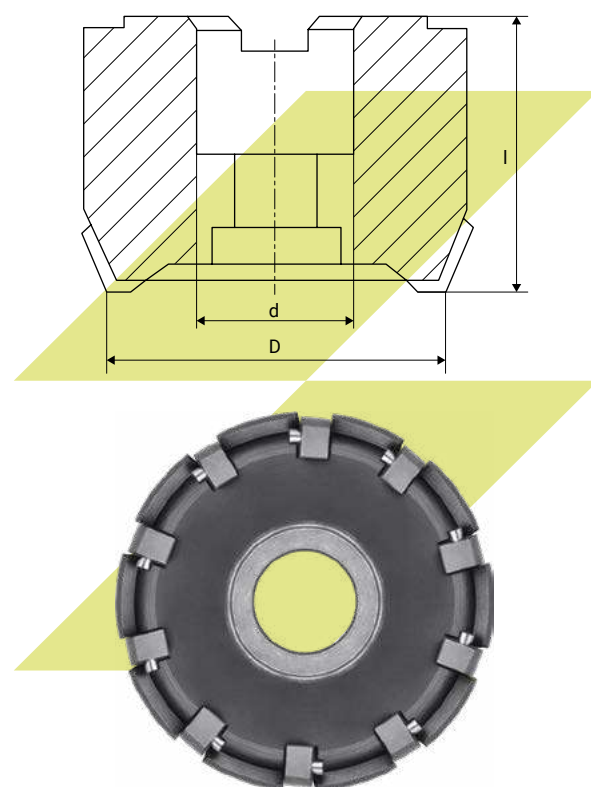

Пластины режущие сменные многогранные твердосплавные пятигранной формы с отверстием

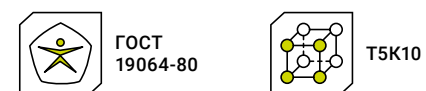

Артикул	Тип	H, мм	l, мм	R, мм	d, мм	Стружколом
104318	PNUA(10113)-110408	4,76	11,50	0,8	6,35	Нет
104322	PNUM(10114)-110408	4,76	11,50	0,8	6,35	Да

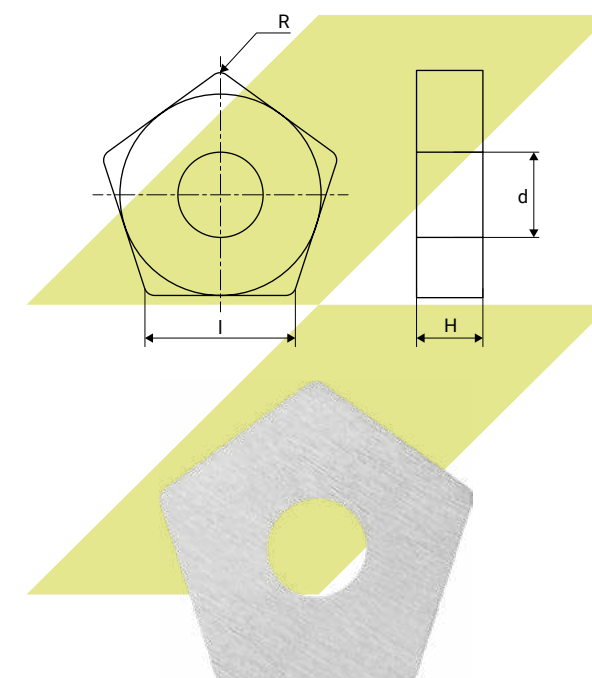

Пластины режущие сменные многогранные твердосплавные пятигранной формы с отверстием



Артикул	Тип	H, мм	L, мм	R, мм	d, мм	Стружколом
104314	PNUA(10113)-110408	4,76	11,50	0,8	6,35	Нет
104320	PNUM(10114)-110408	4,76	11,50	0,8	6,35	Да

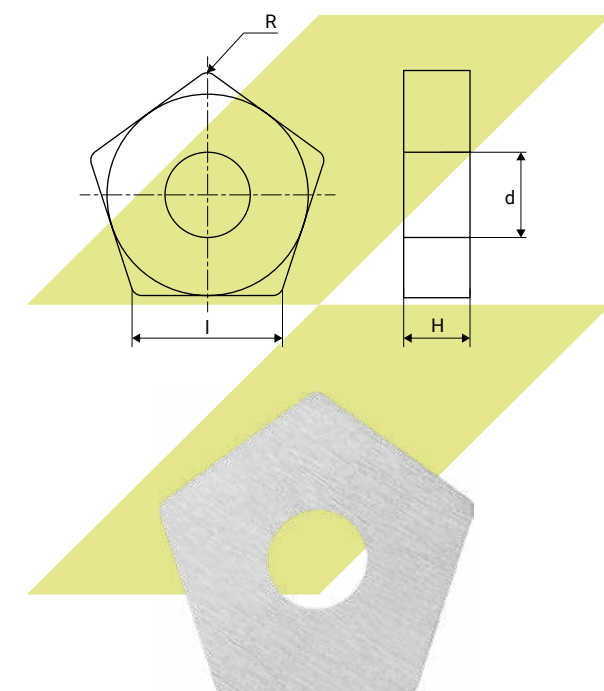

Пластины режущие сменные многогранные твердосплавные пятигранной формы с отверстием

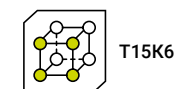

Артикул	Тип	H, мм	L, мм	R, мм	d, мм	Стружколом
104318	PNUA(10113)-110408	4,76	11,50	0,8	6,35	Нет
104322	PNUM(10114)-110408	4,76	11,50	0,8	6,35	Да

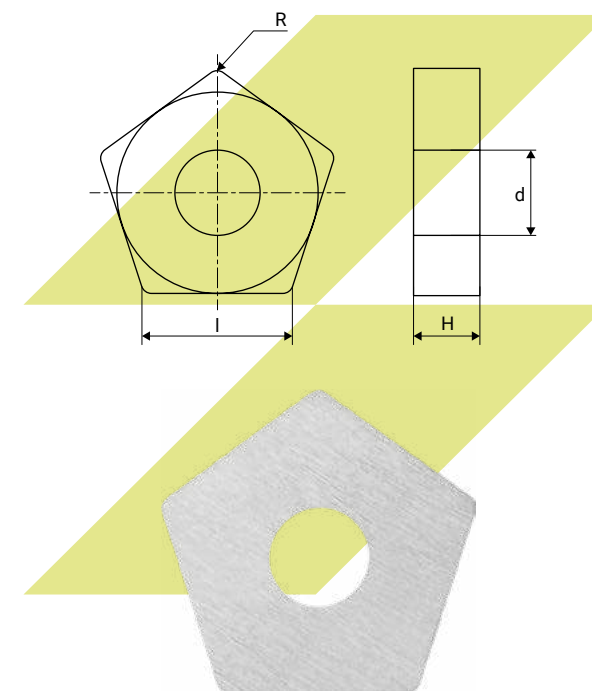

Пластины режущие сменные многогранные безвольфрамовые



Артикул	Тип	l, мм	d, мм	b, мм
117402	03113-120***	15,0	6,35	4,76

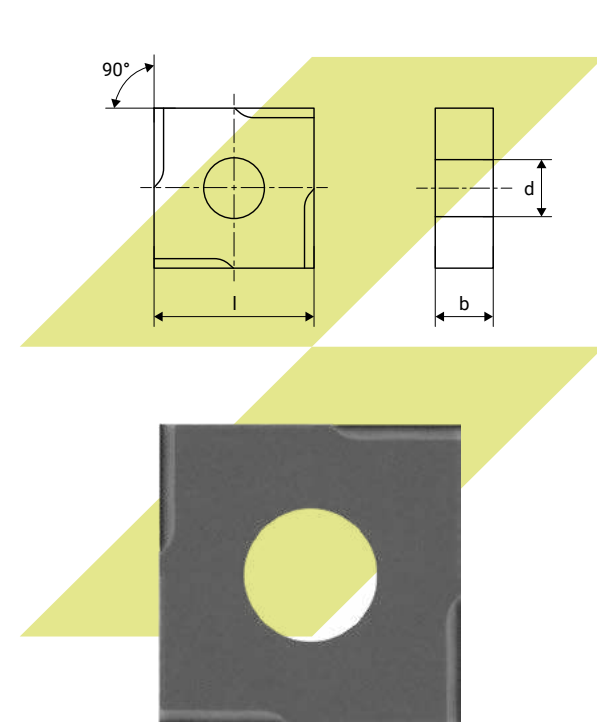
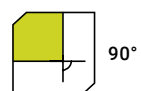

Фрезы торцовые насадные



Артикул	Обозначение по ГОСТ	D, мм	l, мм	d, мм	Z, шт
1135182	—	32,0	35,0	16,0	10
111783	2210-0061	40,0	32,0	16,0	10
111797	2210-0081	63,0	40,0	27,0	8
111798	2210-0071	63,0	40,0	27,0	14
111809	2210-0073	80,0	45,0	32,0	16
111825	2210-0075	100,0	50,0	32,0	18

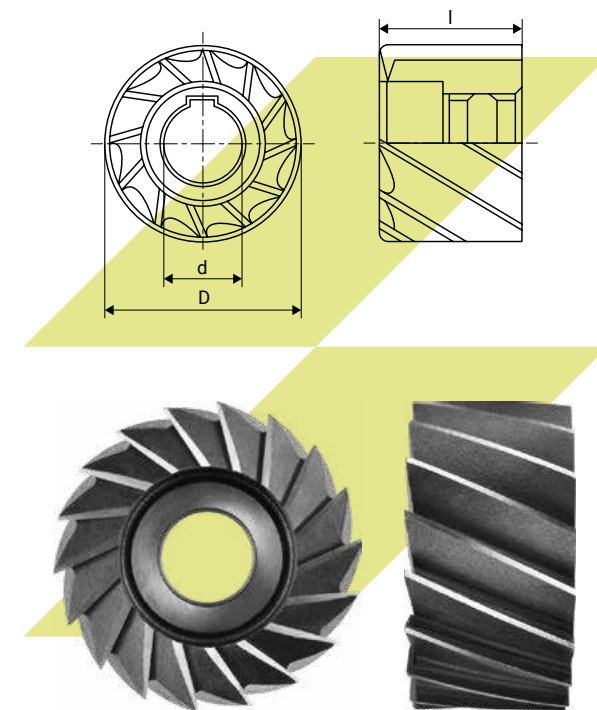

Нарезание и накатывание резьбы

Метчики	424
Машинно-ручные из быстрорежущей стали	424
Бесстружечные (раскатники)	474
Гаечные	476
Ручные	483
Машинно-ручные твердосплавные	484
Плашки круглые	508
М — метрическая	508
G — трубная цилиндрическая	521
K — дюймовая коническая резьба	526
R — трубная коническая	527
BSW/BSF	528
Наборы резьбонарезные	530
Ролики резьбонарезные	532
Ролики резьбонакатные к головке ВНГН и ВНГТ	532
Ролики резьбонакатные к плашкам НП и НРТ	533
Оснастка для нарезания резьбы	541
Воротки для круглых плашек	541
Воротки для метчиков	542

Метчики

Метчики используются при создании резьбовых отверстий. Подходят для обработки заготовок, выполненных из легированной или нержавеющей стали, чугуна, алюминия, меди, бронзы, цинка. Могут быть установлены в патрон металлорежущего оборудования или использованы в ручной работе. Отличаются особой прочностью и устойчивостью к температурным воздействиям. Длинный стержень обеспечивает простоту работы на глубине.



Плашки круглые

Круглые плашки предназначены для нарезания резьбы. Наличие нескольких зон для отвода стружки упрощает работу с металлом и исключает закусывание в процессе резки. Выполнены из легированной стали, благодаря чему отличаются высокой упругостью, износоустойчивостью и твердостью.

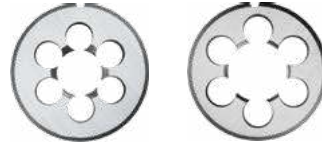

Наборы резьбонарезные

Наборы резьбонарезного инструмента предназначены для работы с мягкими металлами. Инструменты выполнены из легированной стали и обладают высокой прочностью. Применяются для нарезки всевозможных видов резьбы. Наборы поставляются в удобном металлическом кейсе, который обеспечивает надежное хранение инструментов.



Ролики резьбонакатные

Ролики резьбонакатные метрические представляют собой инструмент для получения резьбы пластическим деформированием — накатыванием. Используются для накатки метрической резьбы на круглом прокате различных диаметров.



Оснастка для нарезания резьбы

Оснастка для нарезания резьбы используется для зажима режущего инструмента при нарезании резьбы. Выполнена из качественного цинкового литья, благодаря чему отличается надежностью, долговечностью и стойкостью к коррозии. Длинные рукоятки упрощают вращение и контроль угла.



Условные обозначения

Основные размеры

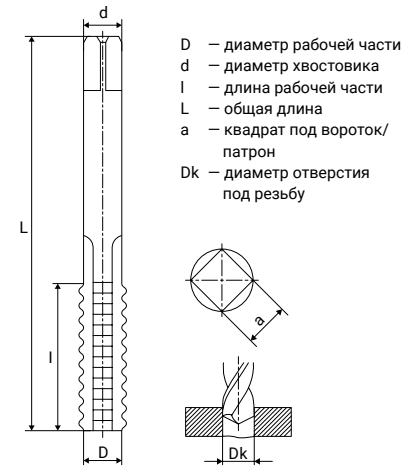

Тип обработки

- Для нарезания резьбы в глухих отверстиях
- Для нарезания резьбы в сквозных отверстиях
- Для нарезания конической резьбы в глухих отверстиях
- Для нарезания конической резьбы в сквозных отверстиях
- Для нарезания резьбы в гайках
- Для нарезания наружной резьбы
- Для нарезания трубной резьбы
- Для нарезания конической резьбы

Обрабатываемый материал

- P Стали
- M Нержавеющая сталь
- K Чугуны
- N Цветные металлы
- S Жаропрочные сплавы
- H Закаленная сталь
- Оптимальное применение
- Возможное применение
- Не применяется



Обозначение стандарта



Обозначение инструментального материала



Класс точности/Квалитет

Вид резьбы

- Метрическая М
- Дюймовая коническая K
- Трубная цилиндрическая G
- Трубная коническая Rc
- Дюймовая BSF
- Дюймовая UNC
- Дюймовая UNF
- Трубная электротехническая PG
- Дюймовая BSW
- Трапецидальная Tr
- Вентильная V

Направление резания

- Правое
- Левое

Применение

- Ручные
- Машинные
- Машинно-ручные

Наличие инструмента

- На складе в Нижнем Новгороде
- Под заказ

Метчики для метрической резьбы

Вид обработки	Ручные, комплект из 2-х штук, М		Для сквозных отверстий машинные и ручные, М			
Стандарт	ОСТ2 И50-1-92	DIN 352	ГОСТ 3266-81	ГОСТ 3266-81	ГОСТ 3266-81	ГОСТ 3266-81
Допуск	7Н	6Н	6Н	6Н	6Н	6Н
Материал	9ХС	Р6М5К5	Р6М5	Р6М5	Р18	Р6М5
Направление резания	Правое	Правое	Правое	Правое	Правое	Левое
Диапазон	M1,2–M27	M2–M24	M0,4–M90	M4–M8	M2–M45	M4–M42
Страница	424	427	429	433	434	436

Вид обработки	Для глухих отверстий машинные и ручные, М					Машинные с винтовыми канавками, М
Стандарт	ГОСТ 3266-81	ГОСТ 3266-81	ГОСТ 3266-81	ГОСТ 3266-81	ГОСТ 3266-81	ГОСТ 17933-72
Допуск	6Н	6Н	6Н	7Н	6Н	6Н
Материал	Р6М5	Р6М5	Р18	Р6М5	Р6М5	Р6М5
Направление резания	Правое	Правое	Правое	Правое	Левое	Правое
Диапазон	M1–M76	M4–M8	M1,8–M36	M4–M14	M2,5–M30	M2–M20
Страница	438	442	443	445	446	448

Метчики для метрической резьбы













Вид обработки	Машинные и ручные, комплект из 2-х штук, М						
Стандарт	ГОСТ 3266-81	ГОСТ 3266-81	ГОСТ 3266-81	ГОСТ 3266-81	ГОСТ 3266-81	ГОСТ 3266-81	ГОСТ 3266-81
Допуск	5Н	6Н	7Н	5Н6Н	6Н	6Н	6Н
Материал	Р6М5	Р6М5	Р6М5	Р6М5	Р18	Р6М5К5	Р6М5
Направление резания	Правое	Правое	Правое	Правое	Правое	Правое	Левое
Диапазон	M2–M27	M1–M76	M2,5–M72	M3–M16	M1,2–M39	M2–M20	M2,5–M42
Страница	450	452	457	459	460	463	465

Вид обработки	Машинные и ручные, комплект из 2-х штук, М	Машинные и ручные, комплект из 3-х штук, М	Машинные с шахматным расположением зубьев, М		
Стандарт	ГОСТ 3266-81	ГОСТ 3266-81	ГОСТ 17927-72	ГОСТ 17927-72	ГОСТ 17927-72
Допуск	7Н	6Н	6Н	6Н	5Н6Н
Материал	Р6М5	Р6М5	Р6М5	Р6М5	Р6М5
Направление резания	Левое	Правое	Правое	Правое	Правое
Диапазон	M8–M30	M1–M52	M3–M36	M2–M30	M2–M8
Страница	467	468	470	472	473









Метчики бесстружечные (раскатники)













Вид обработки		
Стандарт	ГОСТ 18839-73	ГОСТ 18839-73
Допуск	6H	6H
Материал	P6M5	P6M5
Направление резания	Правое	Правое
Диапазон	M1,2–M6	M1,2–M6
Страница	474	475
		

Метчики дюймовые и трубные

Вид обработки	Ручные трубные, комплект из 2-х штук, G		Для дюймовой конической резьбы, K		Машинные и ручные трубные, G		Для трубной конической резьбы, Rc	
								
Стандарт	ОСТ2 И50-1-73		ГОСТ 6227-80		ГОСТ 3266-81	ГОСТ 3266-81	ГОСТ 3266-81	ГОСТ 6227-80
Допуск	—		—		A2	B	A2	—
Материал	9XC		P6M5		P6M5	P6M5	P6M5	P6M5
Направление резания	Правое		Правое		Правое	Левое	Правое	Правое
Диапазон	G1/8"–G2"		K1/16"–K2"		G1/8"–G2"	G1/4"–1/2"	G1/8"–G3"	Rc1/16"–Rc2"
Страница	483		484		485	486	487	488
								

Метчики гаечные









Вид обработки	Гаечные, M			Гаечные с изогнутым хвостовиком, M
				
Стандарт	ГОСТ 1604-71	ГОСТ 1604-71	ГОСТ 1604-71	ГОСТ 6951-71
Допуск	H2	H2	H2	—
Материал	P6M5	P18	P6M5	P6M5
Направление резания	Правое	Правое	Левое	Правое
Диапазон	M1,4–M55	M2,5–M30	M3,0–M42	M2,5–M27
Страница	476	478	480	481
				

Вид обработки	Машинные и ручные UNC, комплект из 2-х штук		Машинные и ручные UNF, комплект из 2-х штук		Трубные электро-технические, PG	Машинные и ручные BSW, комплект из 2-х штук
						
Стандарт	DIN 371	DIN 371	DIN 2181	DIN 2181	DIN 40432	DIN 2184
Допуск	—	—	—	—	—	—
Материал	9XC	9XC	9XC	9XC	P6M5	9XC
Направление резания	Правое	Правое	Правое	Правое	Правое	Правое
Диапазон	UNC1/4–UNC2	UNC №1–UNC №12	UNF1/4–UNF1 1/2	UNF №0–UNF №12	PG7,0–PG21,0	BSW3/32–BSW2
Страница	489	491	492	494	495	496
						



Метчики дюймовые и трубные

Вид обработки	Машинные и ручные BSF, комплект из 2-х штук		Для трапецеидальной резьбы, комплект из 3-х штук, Tr		Машинные и ручные для резьбы вентиля камер и шин, V
					
Стандарт	DIN 2184		ГОСТ 19831-74 DIN 103	ГОСТ 19831-74 DIN 103	DIN 371
Допуск	—		H5	H5	6H
Материал	9XC		P6M5	P6M5	P6M5
Направление резания	Правое		Правое	Левое	Правое
Диапазон	BSF3/16–BSF2		Tr10,0–Tr30,0	Tr10,0–Tr28,0	V5–V20,5
Страница	498		500	502	504
					





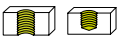

Плашки круглые для метрической резьбы

Вид обработки	Метрические, М					Трубные, G	
							
Стандарт	ГОСТ 9740-71	ГОСТ 9740-71	ГОСТ 9740-71	ГОСТ 9740-71	ГОСТ 9740-71	ГОСТ 9740-71	ГОСТ 9740-71
Допуск	6g	6g	6h	6h	6e	6g	—
Материал	9XC	P6M5	9XC	P6M5	P6M5	9XC	9XC
Направление резания	Правое	Правое	Правое	Правое	Правое	Левое	Правое
Диапазон	M0,5–M124	M1–M56	M1,4–M36	M2–M42	M2–M36	M3–M52	G1/16"–G2 1/4"
Страница	508	511	513	515	517	519	521
							



Метчики твердосплавные

Вид обработки	Машинные и ручные, М	
		
Стандарт	ТУ2-035-446-83	ТУ2-035-446-83
Допуск	6H	6H
Материал	ВК8	ВК8
Направление резания	Правое	Правое
Диапазон	M4–M12	M3–M12
Страница	506	507
		

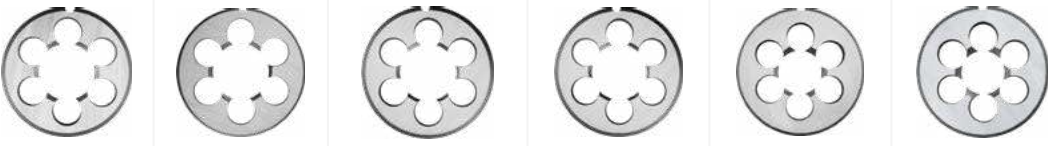





Плашки круглые дюймовые и трубные

Вид обработки	Трубные, G		Для конической дюймовой резьбы, К	Для трубной конической резьбы, R	Для резьбы Витворта, BSF	
						
Стандарт	ГОСТ 9740-71	ГОСТ 9740-71	ГОСТ 6228-80	ГОСТ 6228-80	DIN EN 22568	DIN EN 22568
Допуск	—	—	—	—	—	—
Материал	P6M5	9XC	9XC	9XC	9XC	9XC
Направление резания	Правое	Левое	Правое	Правое	Правое	Правое
Диапазон	G1/8"–G2"	G1/16"–G2 1/4"	K1/16"–K2"	R1/16"–R3 1/4"	BSF3/16–BSF2	BSW1/8–BSW2
Страница	523	524	526	527	528	529
						



Наборы резьбонарезные

	В металлическом футляре	
Материал	9XC	HSS
Страница	530	531
		

Ролики резьбонакатные

	Метрические, М					
Вид головки	ВНГН	НП	–	–	–	–
Стандарт	–	–	ГОСТ 9539-72	ГОСТ 9539-73	ГОСТ 9539-74	ГОСТ 9539-75
Материал	–	–	X6ВФ	X12Ф1	X12МФ	X12М
Вид резьбы	М	М	М	М	М	М
Страница	532	533	534	537	538	539
						

Оснастка для нарезания резьбы

	Воротки для плашек	Вороток для метчиков
Стандарт	ГОСТ 22394-77 ГОСТ 22395-77	DIN 1814
Материал	9XC	–
Диапазон	M1–M62	M1–M64
Страница	541	542
		

Метчики ручные для метрической резьбы, комплект из 2-х штук, М

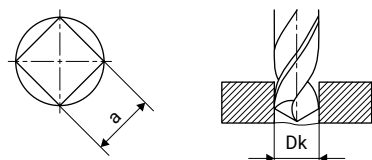
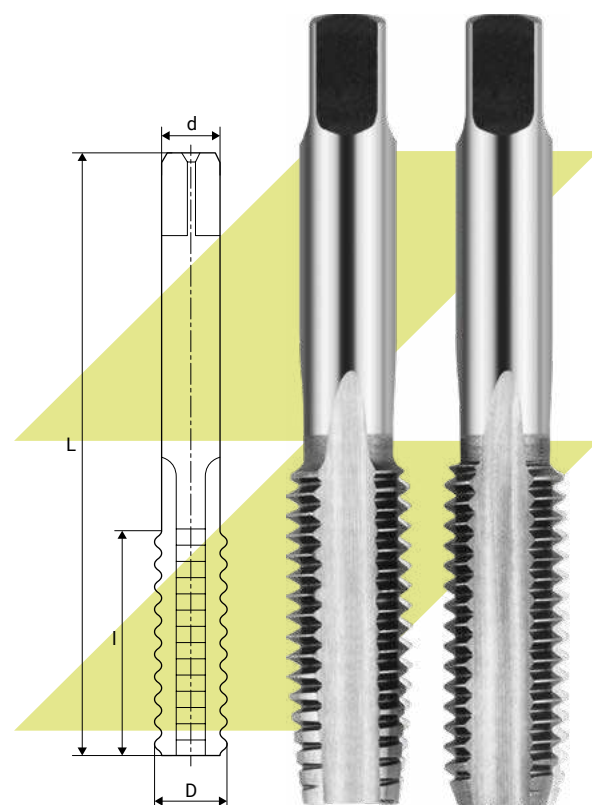
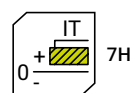
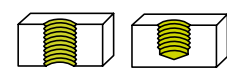

Артикул		D, мм	P, мм	I, мм	L, мм	d, мм	a, мм	Dk, мм
103327	●	1,4	0,30	7,0	40,0	2,50	2,00	1,10
118630	●	1,5	0,35	7,0	40,0	2,50	2,00	1,15
103329	●	1,6	0,35	8,0	41,0	2,50	2,00	1,25
103330	●	1,7	0,35	8,0	41,0	2,50	2,00	1,35
103332	●	1,8	0,35	8,0	41,0	2,50	2,00	1,45
103334	●	2,0	0,40	8,0	41,0	2,50	2,00	1,60
103333	●	2,0	0,25	8,0	41,0	2,50	2,00	1,75
103336	●	2,2	0,45	9,5	44,5	2,80	2,24	1,75
103335	●	2,2	0,25	9,5	44,5	2,80	2,24	1,95
103339	●	2,5	0,45	9,5	44,5	2,80	2,24	2,05
103338	●	2,5	0,35	9,5	44,5	2,80	2,24	2,15
103342	●	3,0	0,50	11,0	48,0	2,24	1,80	2,50

Артикул		D, мм	P, мм	I, мм	L, мм	d, мм	a, мм	Dk, мм
103341	●	3,0	0,35	11,0	48,0	2,24	1,80	2,65
103346	●	3,5	0,60	13,0	50,0	2,50	2,00	2,90
103345	●	3,5	0,35	13,0	50,0	2,50	2,00	3,15
1336250	●	4,0	0,70	13,0	53,0	3,15	2,50	3,30
1336249	●	4,0	0,50	13,0	53,0	3,15	2,50	3,50
1336251	●	5,0	0,80	16,0	58,0	4,00	3,15	4,20
103350	●	5,0	0,50	16,0	58,0	4,00	3,15	4,50
1336252	●	6,0	1,00	19,0	66,0	4,50	3,55	5,00
103355	●	6,0	0,75	19,0	66,0	4,50	3,55	5,20
103354	●	6,0	0,50	19,0	66,0	4,50	3,55	5,50
1336322	●	7,0	1,00	19,0	66,0	5,60	4,50	6,00
1336254	●	8,0	1,25	22,0	72,0	6,30	5,00	6,80
1336253	●	8,0	1,00	22,0	72,0	6,30	5,00	7,00
1336323	●	9,0	1,25	22,0	72,0	7,10	5,60	7,80
1336257	●	10,0	1,50	24,0	80,0	8,00	6,30	8,50
1336256	●	10,0	1,25	24,0	80,0	8,00	6,30	8,80
1336255	●	10,0	1,00	24,0	80,0	8,00	6,30	9,00
103367	●	10,0	0,75	19,0	69,0	8,00	6,30	9,20
1336260	●	12,0	1,75	29,0	89,0	9,00	7,10	10,20
1336259	●	12,0	1,50	29,0	89,0	9,00	7,10	10,50
1336258	●	12,0	1,25	29,0	89,0	9,00	7,10	10,80
1337629	●	12,0	1,00	24,0	84,0	9,00	7,10	11,00
1336263	●	14,0	2,00	30,0	95,0	11,20	9,00	12,00
1336262	●	14,0	1,50	30,0	95,0	11,20	9,00	12,50
1336261	●	14,0	1,25	30,0	95,0	11,20	9,00	12,80
103393	●	16,0	2,00	32,0	102,0	12,50	10,00	14,00
103391	●	16,0	1,50	32,0	102,0	12,50	10,00	14,50
103389	●	16,0	1,00	29,0	90,0	12,50	10,00	15,00
103388	●	16,0	0,75	29,0	90,0	12,50	10,00	15,20
103399	●	18,0	2,50	37,0	112,0	14,00	11,20	15,50
103397	●	18,0	1,50	37,0	112,0	14,00	11,20	16,50
103395	●	18,0	1,00	29,0	95,0	14,00	11,20	17,00
103394	●	18,0	0,75	29,0	95,0	14,00	11,20	17,25
103405	●	20,0	2,50	37,0	112,0	14,00	11,20	17,50
103403	●	20,0	1,50	37,0	112,0	14,00	11,20	18,50
103402	●	20,0	1,00	29,0	102,0	14,00	11,20	19,00
103401	●	20,0	0,75	20,0	102,0	14,00	11,20	19,25
103409	●	22,0	2,50	38,0	118,0	16,00	12,50	19,50
103414	●	24,0	3,00	45,0	130,0	18,00	14,00	21,00

Артикул		D, мм	P, мм	I, мм	L, мм	d, мм	a, мм	Dk, мм
103413	●	24,0	2,00	45,0	130,0	18,00	14,00	22,00
103411	●	24,0	1,00	33,0	113,0	18,00	14,00	23,00
103419	●	27,0	3,00	45,0	135,0	20,00	16,00	24,00
103418	●	27,0	2,00	37,0	127,0	20,00	16,00	25,00
103416	●	27,0	1,50	37,0	127,0	20,00	16,00	25,50
103415	●	27,0	1,00	33,0	120,0	20,00	16,00	26,00

Метчики ручные для метрической резьбы, комплект из 3-х штук, М

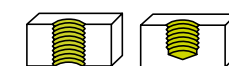

DIN 352

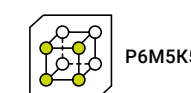

P6M5K5

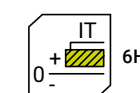

IT 6H

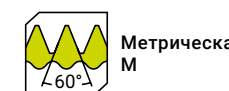

Метрическая М



Ручные



Правое

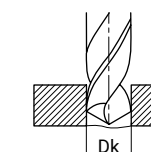
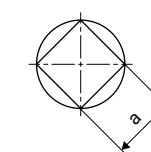
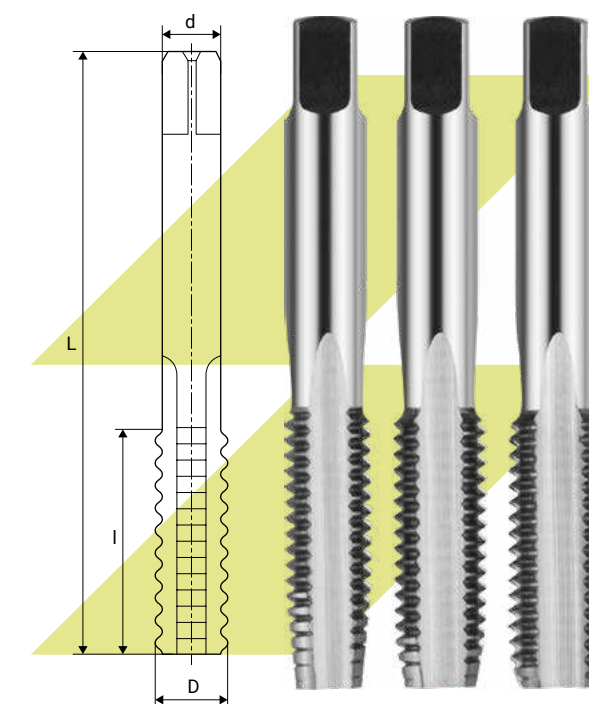

Артикул		D, мм	P, мм	I, мм	L, мм	d, мм	a, мм	Dk, мм
1377760	●	2,0	0,40	8,0	36,0	2,8	2,1	1,60
1377761	●	2,5	0,45	9,0	40,0	2,8	2,1	2,05
1377762	●	3,0	0,50	11,0	40,0	3,5	2,7	2,50
1377763	●	4,0	0,70	13,0	45,0	4,5	3,4	3,30
1377764	●	5,0	0,80	16,0	50,0	6,0	4,9	4,20
1377765	●	6,0	1,00	19,0	50,0	6,0	4,9	5,00
1377766	●	8,0	1,25	22,0	56,0	6,0	4,9	6,80
1377767	●	10,0	1,50	20,0	70,0	7,0	5,5	8,50
1425240	●	12,0	1,75	24,0	75,0	9,0	7,0	10,20
1425241	●	14,0	2,00	26,0	80,0	11,0	9,0	12,00
1425242	●	16,0	2,00	26,0	80,0	12,0	9,0	14,00
1425245	●	18,0	2,50	30,0	95,0	14,0	11,0	15,50

Артикул		D, мм	P, мм	I, мм	L, мм	d, мм	a, мм	Dk, мм
1425243	●	20,0	2,50	32,0	95,0	16,0	12,0	17,50
1425246	●	22,0	2,50	32,0	100,0	18,0	14,5	19,50
1425244	●	24,0	3,00	36,0	110,0	18,0	14,5	21,00

Метчики машинные и ручные для сквозных отверстий, М

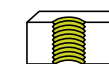

ГОСТ 3266-81

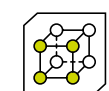

P6M5

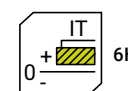

IT 6H

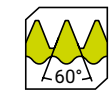

Метрическая М

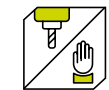

Машинно-ручные

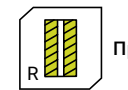

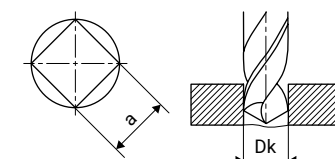
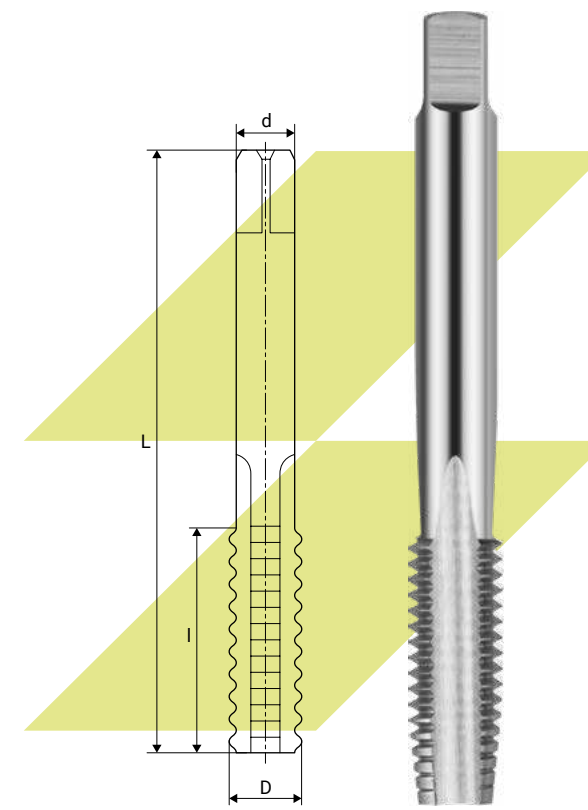

Правое



* до М 0.8 включительно и М 1.8 изготовлены из материала У12А

Артикул		Обозначение по ГОСТ	D, мм	P, мм	I, мм	L, мм	d, мм	a, мм	Dk, мм
1151734	○	—	0,40	0,100	2,6	17,5	1,20	1,00	0,30
1151735	○	—	0,45	0,100	3,0	18,0	1,20	1,00	0,35
1151736	○	—	0,50	0,125	3,1	20,0	1,20	1,00	0,37
1151737	○	—	0,60	0,150	3,1	20,0	1,20	1,00	0,45
1151738	○	—	0,70	0,175	7,0	20,0	1,20	1,00	0,52
1178701	●	2620-3721	1,00	0,250	5,5	38,5	2,50	2,00	0,75
1378771	●	2620-3745	1,20	0,250	5,5	38,5	2,50	2,00	0,95
1337545	●	2620-3757	1,40	0,300	7,0	40,0	2,50	2,00	1,10
1185636	●	2620-3769	1,60	0,350	8,0	41,0	2,50	2,00	1,25
1185638	●	—	1,70	0,350	8,0	41,0	2,50	2,00	1,35
1345862	●	2620-3781	1,80	0,350	8,0	41,0	2,50	2,00	1,45
1151772	●	2620-1011	2,00	0,400	8,0	41,0	2,50	2,00	1,60

Артикул		Обозначение по ГОСТ	D, мм	P, мм	l, мм	L, мм	d, мм	a, мм	Dk, мм
1583237	●	2620-1027	2,20	0,450	9,5	44,5	2,80	2,24	1,75
1151782	●	—	2,30	0,400	9,5	44,5	2,80	2,24	1,90
1178558	●	2620-1035	2,50	0,350	9,5	44,5	2,80	2,24	2,15
1185641	●	2620-1043	2,50	0,450	9,5	44,5	2,80	2,24	2,05
1151799	●	2621-2407	3,00	0,350	11,0	48,0	2,24	1,80	2,65
1326487	●	2621-2401	3,00	0,500	11,0	48,0	2,24	1,80	2,50
1178714	●	2621-2413	3,50	0,600	13,0	50,0	2,50	2,00	2,90
1151834	●	2621-2435	4,00	0,500	13,0	53,0	3,15	2,50	3,50
1151856	●	2620-1089	4,00	0,700	13,0	53,0	4,00	3,15	3,30
1479431	●	2621-2425	4,00	0,700	13,0	53,0	4,00	3,15	3,30
1257888	●	2621-2651	4,00	0,700	13,0	73,0	3,15	2,50	3,30
1261485	●	2621-2441	4,50	0,750	13,0	53,0	4,00	3,15	3,70
1479433	●	2621-1121	5,00	0,800	16,0	58,0	5,00	4,00	4,20
1151900	●	2621-2457	5,00	0,800	16,0	58,0	4,00	3,15	4,20
1419539	●	—	5,00	0,800	16,0	79,0	4,00	3,15	4,20
1234881	●	2621-2473	5,50	0,500	17,0	62,0	4,50	3,55	5,00
1258942	●	2621-2489	6,00	0,750	19,0	66,0	4,50	3,55	5,20
1151950	●	2621-1153	6,00	1,000	19,0	66,0	6,30	5,00	5,00
1479436	●	2621-2481	6,00	1,000	19,0	66,0	4,50	3,55	5,00
1257889	●	2621-2691	6,00	1,000	19,0	89,0	4,50	3,55	5,00
1240376	●	2621-2521	7,00	0,500	19,0	66,0	5,60	4,50	6,50
1240377	●	2621-2513	7,00	0,750	19,0	66,0	5,60	4,50	6,20
1178716	●	2621-2505	7,00	1,000	19,0	66,0	5,60	4,50	6,00
1583239	●	2621-2553	8,00	0,500	19,0	66,0	8,00	6,30	7,50
1261739	●	2621-2545	8,00	0,750	19,0	66,0	8,00	6,30	7,20
1240378	●	2621-2537	8,00	1,000	22,0	72,0	8,00	6,30	7,00
1152013	●	2621-2529	8,00	1,250	22,0	72,0	6,30	5,00	6,80
1178423	●	2621-2561	9,00	1,250	22,0	72,0	7,10	5,60	7,80
1260108	●	2621-2617	10,00	0,750	19,0	69,0	8,00	6,30	9,20
1220927	●	2621-2609	10,00	1,000	24,0	80,0	8,00	6,30	9,00
1252529	●	2621-2601	10,00	1,250	24,0	110,0	8,00	6,30	8,80
1152052	●	2621-2601	10,00	1,250	24,0	80,0	8,00	6,30	8,80
1178428	●	2621-2593	10,00	1,500	24,0	80,0	8,00	6,30	8,50
1479574	●	2621-1457	11,00	1,000	24,0	80,0	8,00	6,30	10,00
1178434	●	—	11,00	1,250	25,0	85,0	8,00	6,30	9,70
1590966	●	2621-1465	11,00	1,500	25,0	85,0	8,00	6,30	9,50
1377910	●	2621-1473	12,00	0,500	19,0	80,0	9,00	7,10	11,50
1261487	●	2621-1489	12,00	1,000	24,0	84,0	9,00	7,10	11,00
1220061	●	2621-1497	12,00	1,250	29,0	89,0	9,00	7,10	10,80

Артикул		Обозначение по ГОСТ	D, мм	P, мм	l, мм	L, мм	d, мм	a, мм	Dk, мм
1178437	●	2621-1505	12,00	1,500	29,0	89,0	9,00	7,10	10,50
1417511	●	2620-1513	12,00	1,750	29,0	89,0	9,00	7,10	10,20
1178439	●	2621-1513	12,00	1,750	29,0	89,0	9,00	7,10	10,20
1178443	●	2621-1521	14,00	0,500	19,0	80,0	11,20	9,00	13,50
1220062	●	2621-1529	14,00	0,750	19,0	84,0	11,20	9,00	13,20
1325993	●	2621-1537	14,00	1,000	24,0	84,0	11,20	9,00	13,00
1179907	●	2621-1545	14,00	1,250	30,0	95,0	11,20	9,00	12,80
1240379	●	2621-1553	14,00	1,500	30,0	95,0	11,20	9,00	12,50
1239180	●	—	14,00	1,750	30,0	95,0	11,20	9,00	12,20
1178449	●	2621-1561	14,00	2,000	30,0	95,0	11,20	9,00	12,00
1269527	●	2621-1569	15,00	1,000	24,0	84,0	11,20	9,00	14,00
1239182	●	2621-1585	16,00	0,500	19,0	80,0	12,50	10,00	15,50
1239183	●	2621-1593	16,00	0,750	20,0	90,0	12,50	10,00	15,20
1479577	●	2621-1601	16,00	1,000	29,0	90,0	12,50	10,00	15,00
1178454	●	—	16,00	1,250	32,0	102,0	12,50	10,00	14,75
1220718	●	2621-1609	16,00	1,500	32,0	102,0	12,50	10,00	14,50
1240380	●	2621-1617	16,00	2,000	32,0	102,0	12,50	10,00	14,00
1152282	○	2621-1649	18,00	0,750	20,0	95,0	14,00	11,20	17,20
1331054	●	2621-1657	18,00	1,000	37,0	95,0	14,00	11,20	17,00
1240381	●	—	18,00	1,250	37,0	112,0	14,00	11,20	16,75
1178462	●	2621-1665	18,00	1,500	37,0	112,0	14,00	11,20	16,50
1152301	●	2621-1673	18,00	2,000	37,0	112,0	14,00	11,20	16,00
1178466	●	2621-1689	20,00	0,500	20,0	90,0	14,00	11,20	19,50
1377913	●	2621-1697	20,00	0,750	20,0	102,0	14,00	11,20	19,25
1178471	●	2621-1721	20,00	2,000	37,0	112,0	14,00	11,20	18,00
1178732	●	2621-1729	20,00	2,500	37,0	112,0	14,00	11,20	17,50
1417895	●	2621-1745	22,00	0,750	20,0	112,0	16,00	12,50	21,20
1178478	●	2621-1761	22,00	1,500	38,0	118,0	16,00	12,50	20,50
1152382	●	2621-1777	22,00	2,500	38,0	118,0	16,00	12,50	19,50
1178480	●	2621-1785	24,00	0,750	25,0	113,0	18,00	14,00	23,25
1479579	●	2621-1793	24,00	1,000	33,0	113,0	18,00	14,00	23,00
1152393	●	2621-1801	24,00	1,500	35,0	120,0	18,00	14,00	22,50
1337555	●	2621-1817	24,00	3,000	45,0	130,0	18,00	14,00	21,00
1583251	●	2621-1847	26,00	1,500	35,0	120,0	18,00	14,00	24,50
1178489	●	2621-1855	27,00	0,750	25,0	120,0	20,00	16,00	26,25
1152422	○	2621-1863	27,00	1,000	33,0	120,0	20,00	16,00	26,00
1378774	●	2621-1871	27,00	1,500	37,0	127,0	20,00	16,00	25,50
1152437	●	2621-1879	27,00	2,000	37,0	127,0	20,00	16,00	25,00
1152445	●	2621-1887	27,00	3,000	45,0	135,0	20,00	16,00	24,00

Артикул	Обозначение по ГОСТ	D, мм	P, мм	l, мм	L, мм	d, мм	a, мм	Dk, мм
1178739	—	27,00	3,500	45,0	135,0	20,00	16,00	23,50
1583254	2621-1893	28,00	1,000	33,0	120,0	20,00	16,00	27,00
1240390	2621-1933	30,00	1,500	37,0	127,0	20,00	16,00	28,50
1240392	2621-1941	30,00	2,000	37,0	127,0	20,00	16,00	28,00
1178500	2621-1949	30,00	3,000	48,0	138,0	20,00	16,00	27,00
1234894	2621-1955	30,00	3,500	48,0	138,0	20,00	16,00	26,50
1377688	2621-1961	32,00	1,500	37,0	137,0	22,40	18,00	30,50
1293031	2621-1993	33,00	1,500	37,0	137,0	22,40	18,00	31,50
1178740	2621-2001	33,00	2,000	37,0	137,0	22,40	18,00	31,00
1152511	2621-2009	33,00	3,000	51,0	151,0	22,40	18,00	30,00
1152515	2621-2015	33,00	3,500	51,0	151,0	22,40	18,00	29,50
1239186	2621-2029	36,00	1,000	32,0	130,0	25,00	20,00	35,00
1379342	2621-2045	36,00	2,000	39,0	144,0	25,00	20,00	34,00
1239187	2621-2053	36,00	3,000	57,0	162,0	25,00	20,00	33,00
1239188	2621-2059	36,00	4,000	57,0	162,0	25,00	20,00	32,00
1178508	2621-2073	39,00	1,000	37,0	144,0	28,00	22,40	38,00
1240395	2621-2097	39,00	3,000	60,0	170,0	28,00	22,40	36,00
1337556	2621-2103	39,00	4,000	60,0	170,0	28,00	22,40	35,00
1479583	2621-2131	42,00	1,000	37,0	144,0	28,00	22,40	41,00
1152581	2621-2139	42,00	1,500	39,0	149,0	28,00	22,40	40,50
1479584	2621-2147	42,00	2,000	39,0	149,0	28,00	22,40	40,00
1337557	2621-2155	42,00	3,000	60,0	170,0	28,00	22,40	39,00
1583256	2621-2167	42,00	4,500	60,0	170,0	28,00	22,40	37,50
1152613	2621-2189	45,00	2,000	45,0	165,0	31,50	25,00	43,00
1152620	2621-2197	45,00	3,000	67,0	187,0	31,50	25,00	42,00
1337559	2621-2209	45,00	4,500	67,0	187,0	31,50	25,00	40,50
1178516	2621-2215	48,00	1,000	37,0	151,0	31,50	25,00	47,00
1419537	2621-2231	48,00	2,000	45,0	165,0	31,50	25,00	46,00
1419538	2621-2239	48,00	3,000	67,0	187,0	31,50	25,00	45,00
1178745	2621-2251	48,00	5,000	67,0	187,0	31,50	25,00	43,00
1178522	2621-2273	50,00	3,000	67,0	187,0	31,50	25,00	47,00
1239189	—	56,00	1,500	45,0	175,0	35,50	28,00	54,50
1152678	—	56,00	2,000	45,0	175,0	35,00	28,00	54,00
1178525	—	60,00	2,000	52,0	190,0	40,00	31,50	58,00
1178746	—	64,00	1,500	52,0	190,0	40,00	31,50	62,50
1337561	—	64,00	2,000	52,0	190,0	40,00	31,50	62,00
1178747	—	64,00	3,000	77,0	210,0	40,00	31,50	61,00
1583258	—	64,00	6,000	79,0	224,0	40,00	31,50	58,00
1152697	—	76,00	2,000	60,0	300,0	42,00	31,50	74,00

Метчики машинные и ручные для сквозных отверстий с покрытием TiN, M

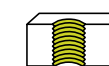

ГОСТ 3266-81

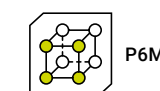

P6M5

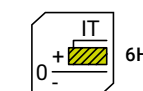

IT 6H



Метрическая M



Машинно-ручные



Правое

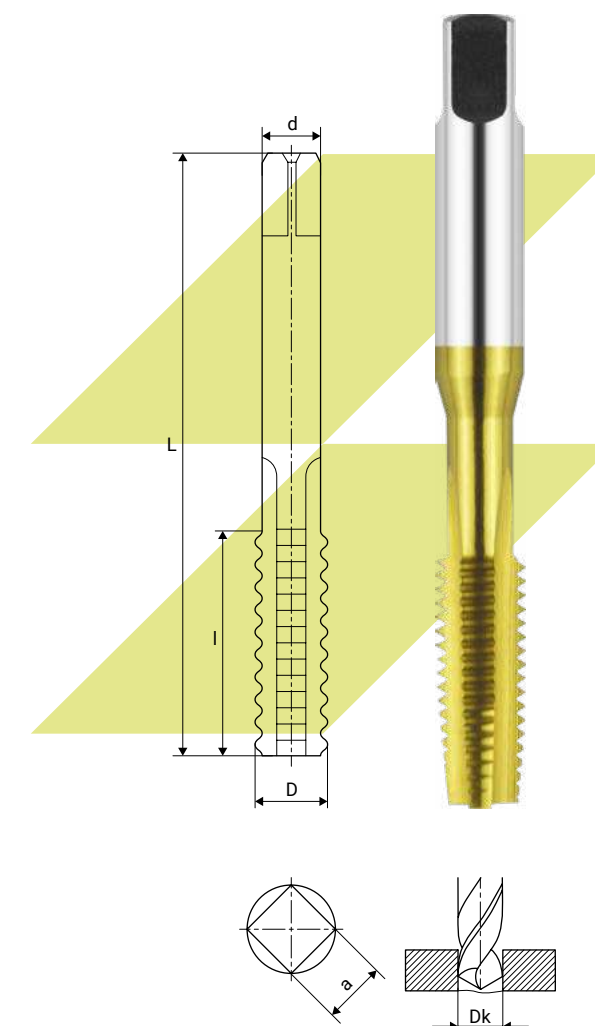

Артикул	D, мм	P, мм	l, мм	L, мм	d, мм	a, мм	Dk, мм
1185664	4,0	0,70	13,0	58,0	3,0	2,50	3,3
1378445	5,0	0,80	16,0	64,0	4,0	3,15	4,2
1253815	5,0	0,80	16,0	64,0	5,0	4,00	4,2
1378446	6,0	1,00	19,0	70,0	4,0	3,15	5,0
1185665	6,0	1,00	19,0	70,0	6,0	5,00	5,0
1185666	8,0	1,25	22,0	70,0	8,0	6,30	6,8

Метчики машинные и ручные для сквозных отверстий, М

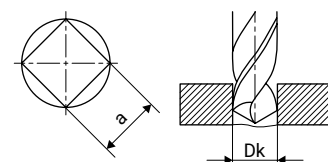
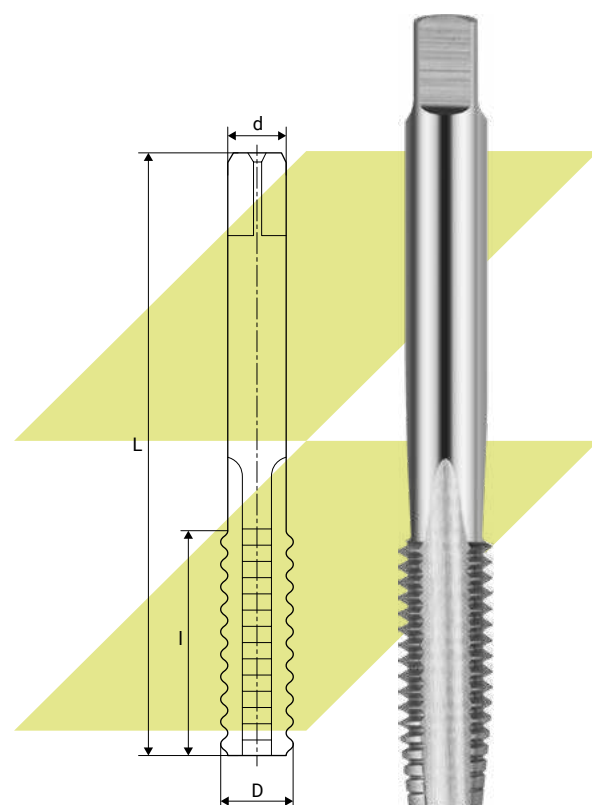
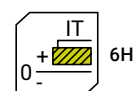
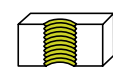

Артикул	Обозначение по ГОСТ	D, мм	P, мм	l, мм	L, мм	d, мм	a, мм	Dk, мм
1325903	2620-1011	2,0	0,40	8,0	41,0	2,50	2,00	1,60
1325904	2620-1043	2,5	0,45	9,5	44,5	2,80	2,24	2,05
1325905	2621-2401	3,0	0,50	11,0	48,0	2,24	1,80	2,50
1345981	2621-2419	3,5	0,35	13,0	50,0	2,50	2,00	3,15
1325906	2621-2425	4,0	0,70	13,0	53,0	4,00	3,15	3,30
1325907	2621-2457	5,0	0,80	16,0	58,0	4,00	3,15	4,20
1325908	2621-2481	6,0	1,00	19,0	66,0	4,50	3,55	5,00
1325909	2621-2529	8,0	1,25	22,0	72,0	6,30	5,00	6,80
1325910	2621-2625	10,0	0,50	19,0	69,0	8,00	6,30	9,50
1325911	2621-2617	10,0	0,75	19,0	69,0	8,00	6,30	9,20
1325912	2621-2609	10,0	1,00	24,0	80,0	8,00	6,30	9,00
1325913	2621-2601	10,0	1,25	24,0	80,0	8,00	6,30	8,80

Артикул	Обозначение по ГОСТ	D, мм	P, мм	l, мм	L, мм	d, мм	a, мм	Dk, мм
1325914	2621-2593	10,0	1,50	24,0	80,0	8,00	6,30	8,50
1325915	2621-1497	12,0	1,25	29,0	89,0	9,00	7,10	10,80
1325916	2621-1505	12,0	1,50	29,0	89,0	9,00	7,10	10,50
1325917	2621-1513	12,0	1,75	29,0	89,0	9,00	7,10	10,20
1325918	2621-1537	14,0	1,00	24,0	84,0	11,20	9,00	13,00
1325919	2621-1545	14,0	1,25	30,0	95,0	11,20	9,00	12,80
1325920	2621-1553	14,0	1,50	30,0	95,0	11,20	9,00	12,50
1325921	2621-1561	14,0	2,00	30,0	95,0	11,20	9,00	12,00
1152238	2621-1601	16,0	1,00	29,0	90,0	12,50	10,00	15,00
1325922	2621-1609	16,0	1,50	32,0	102,0	12,50	10,00	14,50
1325923	2621-1617	16,0	2,00	32,0	102,0	12,50	10,00	14,00
1325924	2621-1665	18,0	1,50	37,0	112,0	14,00	11,20	16,50
1325925	2621-1673	18,0	2,00	37,0	112,0	14,00	11,20	16,00
1325926	2621-1681	18,0	2,50	37,0	112,0	14,00	11,20	15,50
1152321	2621-1697	20,0	0,75	20,0	102,0	14,00	11,20	19,20
1325927	2621-1705	20,0	1,00	29,0	102,0	14,00	11,20	19,00
1325928	2621-1713	20,0	1,50	37,0	112,0	14,00	11,20	18,50
1325929	2621-1721	20,0	2,00	37,0	112,0	14,00	11,20	18,00
1325930	2621-1729	20,0	2,50	37,0	112,0	14,00	11,20	17,50
1325931	2621-1761	22,0	1,50	38,0	118,0	16,00	12,50	20,50
1152381	2621-1777	22,0	2,50	38,0	118,0	16,00	12,50	19,50
1325932	2621-1817	24,0	3,00	45,0	130,0	18,00	14,00	21,00
1152444	2621-1887	27,0	3,00	45,0	135,0	20,00	16,00	24,00
1325933	2621-1933	30,0	1,50	37,0	127,0	20,00	16,00	28,50
1325934	2621-1941	30,0	2,00	37,0	127,0	20,00	16,00	28,00
1325935	2621-1949	30,0	3,00	48,0	138,0	20,00	16,00	27,00
1325936	2621-1955	30,0	3,50	48,0	138,0	20,00	16,00	26,50
1325937	2621-1993	33,0	1,50	37,0	137,0	22,40	18,00	31,50
1325938	2621-2001	33,0	2,00	37,0	137,0	22,40	18,00	31,00
1152580	2621-2139	42,0	1,50	39,0	149,0	28,00	22,40	40,50
1152607	2621-2181	45,0	1,50	45,0	165,0	31,50	25,00	43,50
1152612	2621-2189	45,0	2,00	45,0	165,0	31,50	25,00	43,00

Метчики машинные и ручные для сквозных отверстий, левые, М

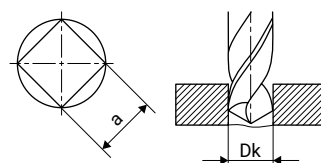
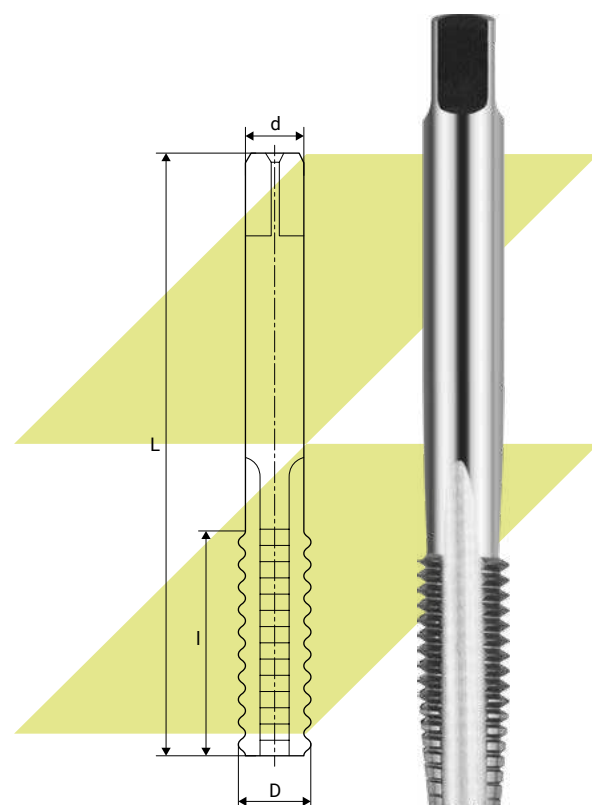
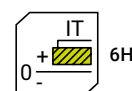
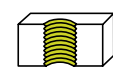

Артикул	Обозначение по ГОСТ	D, мм	P, мм	l, мм	L, мм	d, мм	a, мм	Dk, мм
1378364	2620-1082	4,0	0,50	13,0	53,0	4,0	3,15	3,50
1182679	2621-2426	4,0	0,70	13,0	50,0	3,2	2,50	3,30
1518375	2621-2482	6,0	1,00	19,0	66,0	4,5	3,55	5,00
1234883	2621-2546	8,0	0,75	19,0	66,0	8,0	6,30	7,20
1178718	2621-2530	8,0	1,25	22,0	72,0	8,0	6,30	6,80
1182680	2621-2602	10,0	1,25	24,0	80,0	8,0	6,30	8,80
1178429	2621-2594	10,0	1,50	24,0	80,0	8,0	6,30	8,50
1583244	2621-1498	12,0	1,25	29,0	89,0	9,0	7,10	10,80
1178440	2621-1514	12,0	1,75	29,0	89,0	9,0	7,10	10,20
1178445	2621-1546	14,0	1,25	30,0	95,0	11,2	9,00	12,80
1178723	2621-1554	14,0	1,50	30,0	95,0	11,2	9,00	12,50
1234886	—	14,0	1,75	30,0	95,0	11,2	9,00	12,25

Артикул	Обозначение по ГОСТ	D, мм	P, мм	l, мм	L, мм	d, мм	a, мм	Dk, мм
1178456	2621-1610	16,0	1,50	32,0	102,0	12,5	10,00	14,50
1178458	2621-1618	16,0	2,00	32,0	102,0	12,5	10,00	14,00
1239184	2621-1666	18,0	1,50	37,0	112,0	14,0	11,20	16,50
1178729	2621-1674	18,0	2,00	37,0	112,0	14,0	11,20	16,00
1178465	2621-1682	18,0	2,50	37,0	112,0	14,0	11,20	15,50
1178731	2621-1714	20,0	1,50	37,0	112,0	14,0	11,20	18,50
1152359	2621-1730	20,0	2,50	37,0	112,0	14,0	11,20	17,50
1152385	2621-1778	22,0	2,50	38,0	118,0	16,0	12,50	19,50
1220064	2621-1810	24,0	2,00	35,0	120,0	18,0	14,00	22,00
1178484	2621-1818	24,0	3,00	45,0	130,0	18,0	14,00	21,00
1583253	2621-1872	27,0	1,50	37,0	127,0	20,0	16,00	25,50
1178491	2621-1888	27,0	3,00	45,0	135,0	20,0	16,00	24,00
1254690	2621-1956	30,0	3,50	48,0	138,0	20,0	16,00	26,50
1178506	2621-2038	36,0	1,50	39,0	144,0	25,0	20,00	34,50
1152548	2621-2060	36,0	4,00	57,0	162,0	25,0	20,00	32,00
1416844	2621-2140	42,0	1,50	39,0	149,0	28,0	22,40	40,50
1178743	2621-2168	42,0	4,50	60,0	170,0	28,0	22,40	37,50

Нарезание и накатывание резьбы

Нарезание и накатывание резьбы

Метчики машинные и ручные для глухих отверстий, М

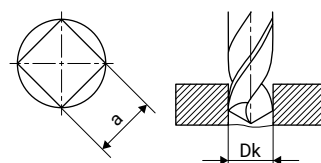
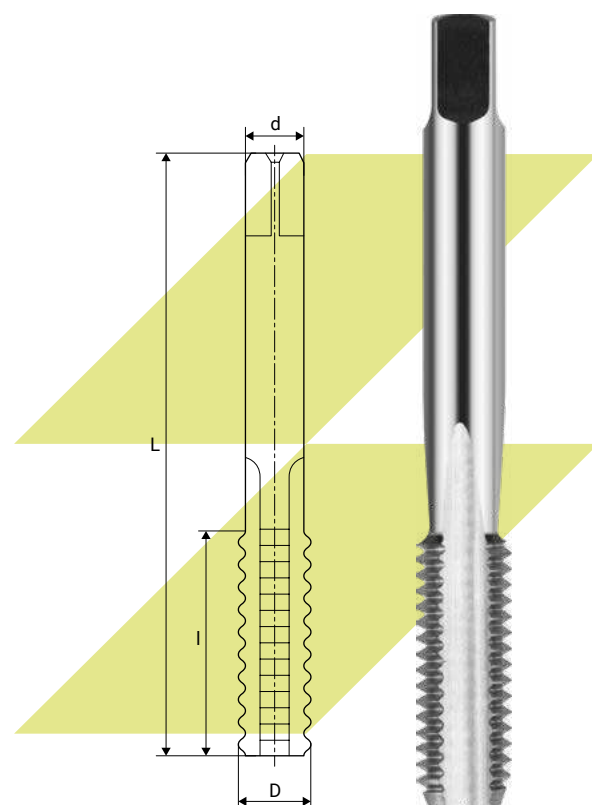
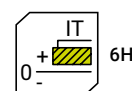
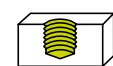

Артикул	Обозначение по ГОСТ	D, мм	P, мм	l, мм	L, мм	d, мм	a, мм	Dk, мм
1185634	2620-3723	1,0	0,25	5,5	38,5	2,50	2,00	0,75
1378770	2620-3747	1,2	0,25	5,5	38,5	2,50	2,00	0,95
1378772	2620-3759	1,4	0,30	7,0	40,0	2,50	2,00	1,10
1185635	2620-3771	1,6	0,35	8,0	41,0	2,50	2,00	1,25
1185637	—	1,7	0,35	8,0	41,0	2,50	2,00	1,35
1185639	2620-1013	2,0	0,40	8,0	41,0	2,50	2,00	1,60
1185640	2620-1045	2,5	0,45	9,5	44,5	2,80	2,24	2,05
1227754	2620-1037	2,5	0,35	9,5	44,5	2,80	2,24	2,15
1345980	2621-2409	3,0	0,35	11,0	48,0	2,24	1,80	2,65
1378775	2620-1077	3,5	0,60	13,0	50,0	3,55	2,80	2,90
1227755	2621-2427	4,0	0,70	13,0	53,0	3,15	2,50	3,30
1346035	2621-2451	4,0	0,50	13,0	53,0	3,15	2,50	3,50

Артикул	Обозначение по ГОСТ	D, мм	P, мм	l, мм	L, мм	d, мм	a, мм	Dk, мм
1227756	2621-2459	5,0	0,80	16,0	58,0	4,00	3,15	4,20
1337868	2621-2467	5,0	0,50	16,0	58,0	4,00	3,15	4,50
1239177	2621-2475	5,5	0,50	17,0	62,0	4,50	3,55	5,00
1220058	2621-1155	6,0	1,00	19,0	66,0	6,30	5,00	5,00
1479435	2621-2483	6,0	1,00	19,0	66,0	4,50	3,55	5,00
1258941	2621-2491	6,0	0,75	19,0	66,0	4,50	3,55	5,20
1151915	2621-2499	6,0	0,50	19,0	66,0	4,50	3,55	5,50
1234882	2621-2507	7,0	1,00	19,0	66,0	5,60	4,50	6,00
1343028	—	8,0	1,50	22,0	72,0	6,30	5,00	6,50
1220059	2621-2531	8,0	1,25	22,0	72,0	6,30	5,00	6,80
1337546	2621-2539	8,0	1,00	22,0	72,0	8,00	6,30	7,00
1479568	2621-2547	8,0	0,75	19,0	66,0	8,00	6,30	7,20
1220060	2621-2595	10,0	1,50	24,0	80,0	8,00	6,30	8,50
1227757	2621-2603	10,0	1,25	24,0	80,0	8,00	6,30	8,80
1220928	2621-2611	10,0	1,00	24,0	80,0	8,00	6,30	9,00
1152039	2621-2619	10,0	0,75	19,0	69,0	8,00	6,30	9,20
1152108	2621-1467	11,0	1,50	25,0	85,0	8,00	6,30	9,50
1185642	2621-1515	12,0	1,75	29,0	89,0	9,00	7,10	10,20
1261534	2621-1507	12,0	1,50	29,0	89,0	9,00	7,10	10,50
1227758	2621-1499	12,0	1,25	29,0	89,0	9,00	7,10	10,80
1261516	2621-1491	12,0	1,00	24,0	84,0	9,00	7,10	11,00
1152114	2621-1483	12,0	0,75	19,0	80,0	9,00	7,10	11,20
1377911	2621-1475	12,0	0,50	19,0	80,0	9,00	7,10	11,50
1337549	2621-1563	14,0	2,00	30,0	95,0	11,20	9,00	12,00
1234885	—	14,0	1,75	30,0	95,0	11,20	9,00	12,20
1337548	2621-1555	14,0	1,50	30,0	95,0	11,20	9,00	12,50
1239179	2621-1547	14,0	1,25	30,0	95,0	11,20	9,00	12,80
1325992	2621-1539	14,0	1,00	24,0	84,0	11,20	9,00	13,00
1227759	2621-1531	14,0	0,75	19,0	84,0	11,20	9,00	13,20
1239178	2621-1523	14,0	0,50	19,0	80,0	11,20	9,00	13,50
1269526	2621-1571	15,0	1,00	24,0	84,0	11,20	9,00	14,00
1240774	2621-1619	16,0	2,00	32,0	102,0	12,50	10,00	14,00
1234889	—	16,0	1,25	32,0	102,0	12,50	10,00	14,75
1418141	2621-1603	16,0	1,00	29,0	90,0	12,50	10,00	15,00
1234888	2621-1595	16,0	0,75	20,0	90,0	12,50	10,00	15,25
1234887	2621-1587	16,0	0,50	19,0	80,0	12,50	10,00	15,50
1240383	2621-1675	18,0	2,00	37,0	112,0	14,00	11,20	16,00
1240382	2621-1667	18,0	1,50	37,0	112,0	14,00	11,20	16,50
1152284	2621-1659	18,0	1,00	37,0	95,0	14,00	11,20	17,00

Артикул		Обозначение по ГОСТ	D, мм	P, мм	l, мм	L, мм	d, мм	a, мм	Dk, мм
1377912	●	2621-1643	18,0	0,50	19,0	80,0	14,00	11,20	17,50
1337552	●	2621-1731	20,0	2,50	37,0	112,0	14,00	11,20	17,50
1240385	●	2621-1723	20,0	2,00	37,0	112,0	14,00	11,20	18,00
1240384	●	2621-1715	20,0	1,50	37,0	112,0	14,00	11,20	18,50
1234543	●	2621-1691	20,0	0,50	20,0	90,0	14,00	11,20	19,50
1152380	●	2621-1779	22,0	2,50	38,0	118,0	16,00	12,50	19,50
1240387	●	2621-1771	22,0	2,00	38,0	118,0	16,00	12,50	20,00
1240386	●	2621-1763	22,0	1,50	38,0	118,0	16,00	12,50	20,50
1152366	●	2621-1755	22,0	1,00	29,0	112,0	16,00	12,50	21,00
1417894	●	2621-1747	22,0	0,75	20,0	112,0	16,00	12,50	21,20
1377679	●	2621-1819	24,0	3,00	45,0	130,0	18,00	14,00	21,00
1583249	●	2621-1803	24,0	1,50	35,0	120,0	18,00	14,00	22,50
1152389	●	2621-1795	24,0	1,00	33,0	113,0	18,00	14,00	23,00
1378529	●	2621-1849	26,0	1,50	35,0	120,0	18,00	14,00	24,50
1479581	●	2621-1889	27,0	3,00	45,0	135,0	20,00	16,00	24,00
1479580	●	2621-1881	27,0	2,00	37,0	127,0	20,00	16,00	25,00
1378773	●	2621-1873	27,0	1,50	37,0	127,0	20,00	16,00	25,50
1152421	●	2621-1865	27,0	1,00	33,0	120,0	20,00	16,00	26,00
1240388	●	2621-1857	27,0	0,75	25,0	120,0	20,00	16,00	26,25
1239185	●	2621-1967	30,0	3,50	48,0	138,0	20,00	16,00	26,50
1182000	●	2621-1951	30,0	3,00	48,0	138,0	20,00	16,00	27,00
1240391	●	2621-1943	30,0	2,00	37,0	127,0	20,00	16,00	28,00
1152457	●	2621-1927	30,0	1,00	33,0	120,0	20,00	16,00	29,00
1377687	●	2621-1963	32,0	1,50	37,0	137,0	22,40	18,00	30,50
1152514	○	2621-2019	33,0	3,50	51,0	151,0	22,40	18,00	29,50
1240393	●	2621-2003	33,0	2,00	37,0	137,0	22,40	18,00	31,00
1293030	●	2621-1995	33,0	1,50	37,0	137,0	22,40	18,00	31,50
1152490	●	2621-1987	33,0	1,00	32,0	130,0	22,40	18,00	32,00
1234897	●	2621-2053	36,0	4,00	57,0	162,0	25,00	20,00	32,00
1234896	●	2621-2045	36,0	3,00	57,0	162,0	25,00	20,00	33,00
1379341	●	2621-2047	36,0	2,00	39,0	144,0	25,00	20,00	34,00
1234895	●	2621-2031	36,0	1,00	32,0	130,0	25,00	20,00	35,00
1152565	●	2621-2101	39,0	3,00	60,0	170,0	28,00	22,40	36,00
1152561	●	2621-2091	39,0	2,00	39,0	149,0	28,00	22,40	37,00
1152555	●	2621-2083	39,0	1,50	39,0	149,0	28,00	22,40	37,50
1240394	●	2621-2075	39,0	1,00	37,0	144,0	28,00	22,40	38,00
1181786	●	2621-2169	42,0	4,50	60,0	170,0	28,00	22,40	37,50
1240396	●	2621-2157	42,0	3,00	60,0	170,0	28,00	22,40	39,00
1152579	●	2621-2141	42,0	1,50	39,0	149,0	28,00	22,40	40,50

Артикул		Обозначение по ГОСТ	D, мм	P, мм	l, мм	L, мм	d, мм	a, мм	Dk, мм
1152624	●	2621-2213	45,0	4,50	67,0	187,0	31,50	25,00	40,50
1378776	●	2621-2253	48,0	5,00	67,0	187,0	31,50	25,00	43,00
1337560	●	2621-2241	48,0	3,00	67,0	187,0	31,50	25,00	45,00
1240397	●	2621-2233	48,0	2,00	45,0	165,0	31,50	25,00	46,00
1583257	●	2621-2225	48,0	1,50	45,0	165,0	31,50	25,00	46,50
1378764	●	—	56,0	5,50	70,0	200,0	35,00	28,00	50,50
1234898	●	—	56,0	1,50	45,0	175,0	35,00	28,00	54,50
1220063	●	—	60,0	2,00	52,0	190,0	40,00	31,50	58,00
1378766	●	—	64,0	6,00	79,0	224,0	40,00	31,50	58,00
1234899	●	—	64,0	1,50	52,0	190,0	40,00	31,50	62,50

Метчики машинные и ручные для глухих отверстий с покрытием TiN, M

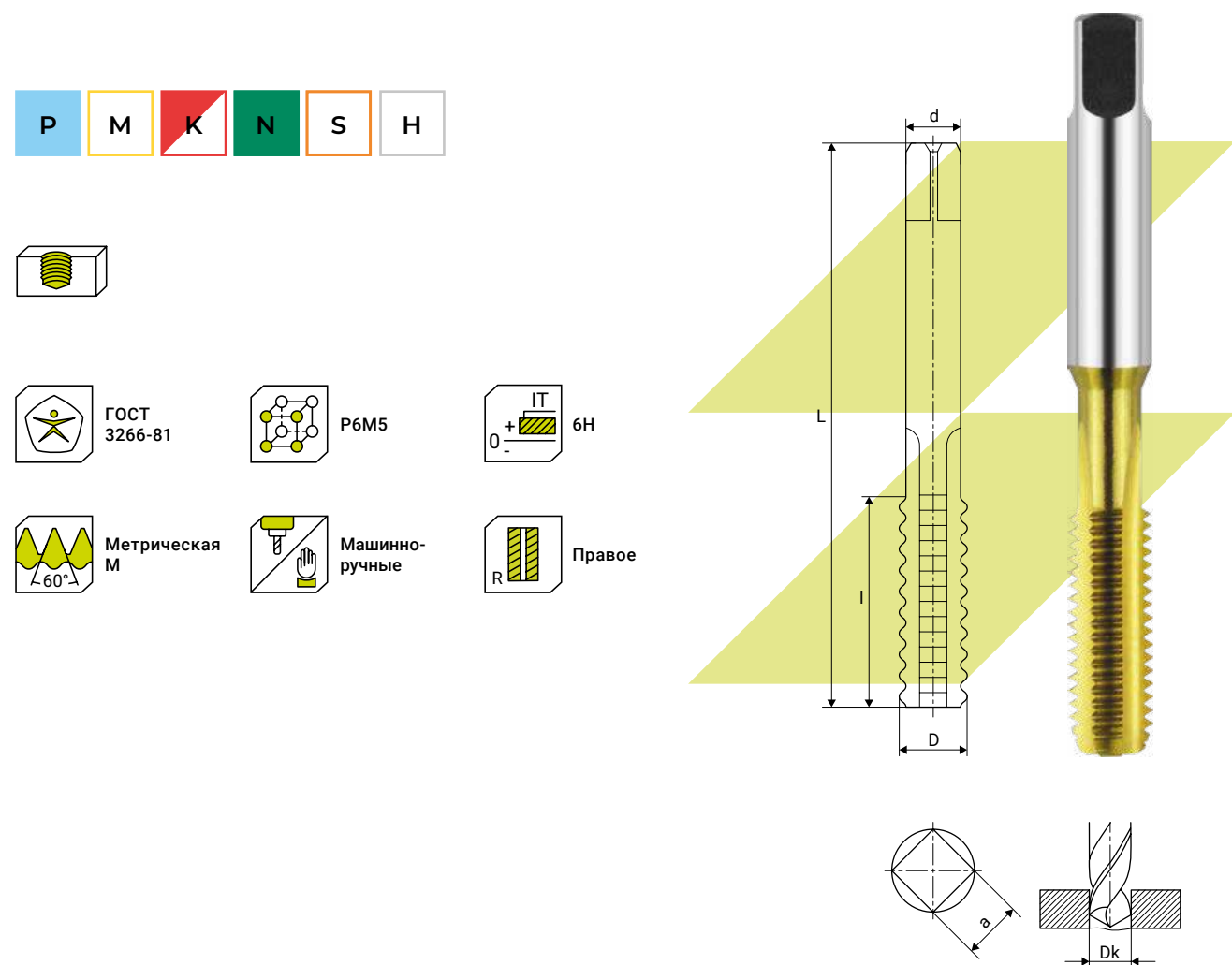

Артикул	Обозначение по ГОСТ	D, мм	P, мм	l, мм	L, мм	d, мм	a, мм	Dk, мм
1417026	2621-2427	4,0	0,70	13,0	53,0	4,0	3,15	3,3
1378447	2621-2531	8,0	1,25	22,0	72,0	6,0	5,00	6,8
1220829	2621-2531	8,0	1,25	22,0	72,0	8,0	6,30	6,8

Метчики машинные и ручные для глухих отверстий, M

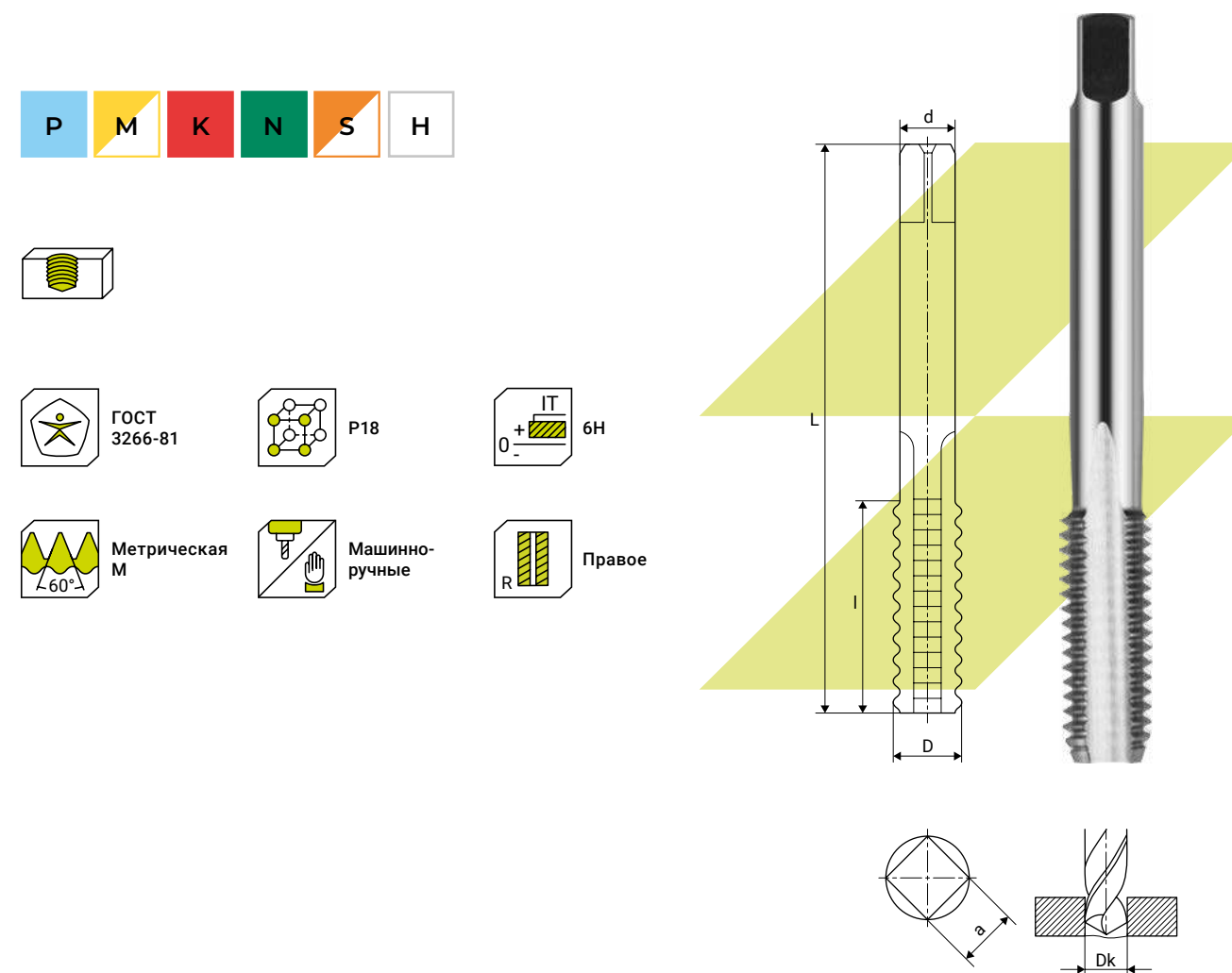

Артикул	Обозначение по ГОСТ	D, мм	P, мм	l, мм	L, мм	d, мм	a, мм	Dk, мм
1331102	2620-3783	1,8	0,20	8,0	41,0	2,50	2,00	1,60
1325869	2620-1013	2,0	0,40	8,0	41,0	2,50	2,00	1,60
1325870	2620-1045	2,5	0,45	9,5	44,5	2,80	2,24	2,05
1325871	2621-2403	3,0	0,50	11,0	48,0	2,24	1,80	2,50
1325872	2621-2427	4,0	0,70	13,0	53,0	3,15	2,50	3,30
1325873	2621-2459	5,0	0,80	16,0	58,0	4,00	3,15	4,20
1325874	2621-2483	6,0	1,00	19,0	66,0	4,50	3,55	5,00
1325875	2621-2531	8,0	1,25	22,0	72,0	6,30	5,00	6,80
1325878	2621-2595	10,0	1,50	24,0	80,0	8,00	6,30	8,50
1325877	2621-2603	10,0	1,25	24,0	80,0	8,00	6,30	8,80
1325876	2621-2611	10,0	1,00	24,0	80,0	8,00	6,30	9,00
1325881	2621-1515	12,0	1,75	29,0	89,0	9,00	7,10	10,20

Нарезание и накатывание резьбы

Нарезание и накатывание резьбы

Артикул	Обозначение по ГОСТ	D, мм	P, мм	l, мм	L, мм	d, мм	a, мм	Dk, мм
1325880	2621-1507	12,0	1,50	29,0	89,0	9,00	7,10	10,50
1325879	2621-1499	12,0	1,25	29,0	89,0	9,00	7,10	10,80
1325885	2621-1563	14,0	2,00	30,0	95,0	11,20	9,00	12,00
1325884	2621-1555	14,0	1,50	30,0	95,0	11,20	9,00	12,50
1325883	2621-1547	14,0	1,25	30,0	95,0	11,20	9,00	12,75
1325882	2621-1539	14,0	1,00	24,0	84,0	11,20	9,00	13,00
1325887	2621-1619	16,0	2,00	32,0	102,0	12,50	10,00	14,00
1325886	2621-1523	16,0	1,50	32,0	102,0	12,50	10,00	14,50
1325890	2621-1683	18,0	2,50	37,0	112,0	14,00	11,20	15,50
1325889	2621-1675	18,0	2,00	37,0	112,0	14,00	11,20	16,00
1325888	2621-1667	18,0	1,50	37,0	112,0	14,00	11,20	16,50
1325894	2621-1731	20,0	2,50	37,0	112,0	14,00	11,20	17,50
1325893	2621-1723	20,0	2,00	37,0	112,0	14,00	11,20	18,00
1325892	2621-1715	20,0	1,50	37,0	112,0	14,00	11,20	18,50
1325891	2621-1707	20,0	1,00	29,0	102,0	14,00	11,20	19,00
1325895	2621-1763	22,0	1,50	38,0	118,0	16,00	12,50	20,50
1325896	2621-1819	24,0	3,00	45,0	130,0	18,00	14,00	21,00
1325900	2621-1967	30,0	3,50	48,0	138,0	20,00	16,00	26,50
1325899	2621-1951	30,0	3,00	48,0	138,0	20,00	16,00	27,00
1325898	2621-1943	30,0	2,00	37,0	127,0	20,00	16,00	28,00
1325897	2621-1935	30,0	1,50	37,0	127,0	20,00	16,00	28,50
1325902	2621-2003	33,0	2,00	37,0	137,0	22,40	18,00	31,00
1325901	2621-1995	33,0	1,50	37,0	137,0	22,40	18,00	31,50
1377843	2621-2045	36,0	3,00	57,0	162,0	25,00	20,00	33,00

Метчики машинные и ручные для глухих отверстий, М

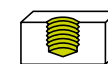

ГОСТ 3266-81

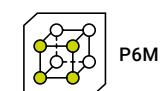

P6M5

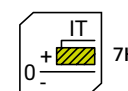

IT 7H



Метрическая М



Машинно-ручные



Правое

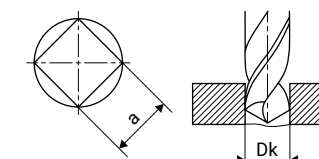
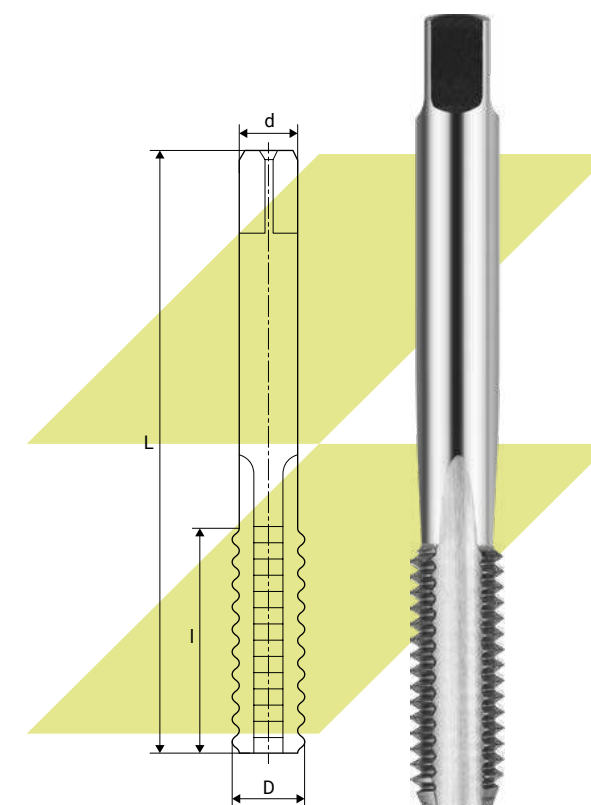

Артикул	Обозначение по ГОСТ	D, мм	P, мм	l, мм	L, мм	d, мм	a, мм	Dk, мм
1253635	2621-2427	4,0	0,70	13,0	53,0	3,15	2,50	3,3
1253636	2621-2459	5,0	0,80	16,0	58,0	4,00	3,15	4,2
1253637	2621-2483	6,0	1,00	19,0	66,0	4,50	3,55	5,0
1261486	2621-2491	6,0	0,75	19,0	66,0	4,50	3,55	5,2
1253638	2621-2531	8,0	1,25	22,0	72,0	8,00	6,30	6,8
1253639	2621-2595	10,0	1,50	24,0	80,0	8,00	6,30	8,5
1253640	2621-1515	12,0	1,75	29,0	89,0	9,00	7,10	10,2
1261489	2621-1539	14,0	1,00	24,0	84,0	11,20	9,00	13,0

Нарезание и накатывание резьбы

Нарезание и накатывание резьбы

Метчики машинные и ручные для глухих отверстий, левые, М

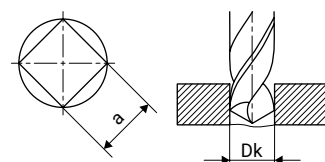
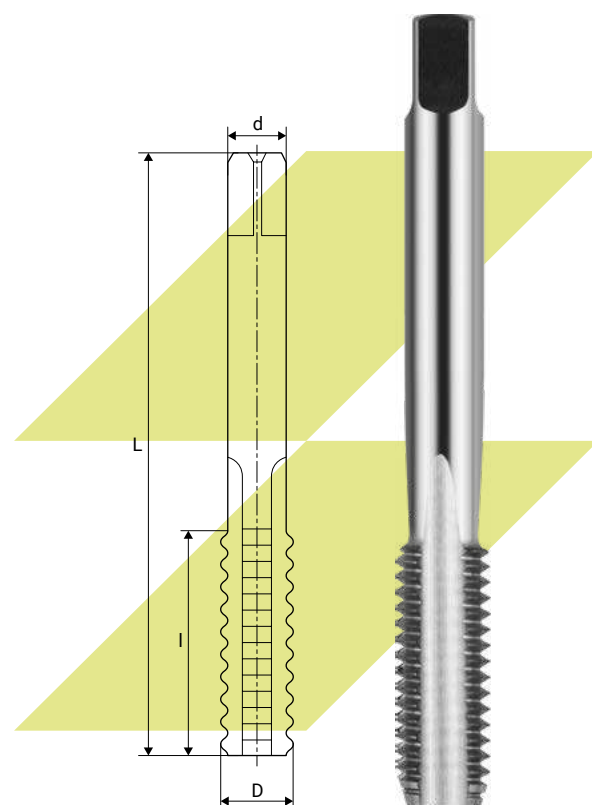
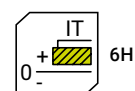
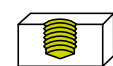

Артикул	Обозначение по ГОСТ	D, мм	P, мм	l, мм	L, мм	d, мм	a, мм	Dk, мм
1151825	2621-2404	3,0	0,50	11,0	48,0	2,24	1,80	2,50
1378363	2620-1084	4,0	0,50	13,0	53,0	4,00	3,15	3,50
1240400	2621-2460	5,0	0,80	16,0	58,0	4,00	3,15	4,20
1518374	2621-2484	6,0	1,00	19,0	66,0	4,50	3,55	5,00
1234884	2621-2532	8,0	1,25	22,0	72,0	8,00	6,30	6,80
1269370	2621-2548	8,0	0,75	19,0	66,0	8,00	6,30	7,20
1342999	2621-2572	9,0	1,00	22,0	72,0	7,10	5,60	8,00
1240403	2621-2596	10,0	1,50	24,0	80,0	8,00	6,30	8,50
1240402	2621-2604	10,0	1,25	24,0	80,0	8,00	6,30	8,80
1240401	2621-2612	10,0	1,00	24,0	80,0	8,00	6,30	9,00
1227783	2621-1516	12,0	1,75	29,0	89,0	9,00	7,10	10,20
1326031	2621-1508	12,0	1,50	29,0	89,0	9,00	7,10	10,50

Артикул	Обозначение по ГОСТ	D, мм	P, мм	l, мм	L, мм	d, мм	a, мм	Dk, мм
1479575	2621-1500	12,0	1,25	29,0	89,0	9,00	7,10	10,80
1479576	2621-1564	14,0	2,00	30,0	95,0	11,20	9,00	12,00
1239181	—	14,0	1,75	30,0	95,0	11,20	9,00	12,25
1234891	2621-1620	16,0	2,00	32,0	102,0	12,50	10,00	14,00
1234890	2621-1612	16,0	1,50	32,0	102,0	12,50	10,00	14,50
1425292	2621-1604	16,0	1,00	29,0	90,0	12,50	10,00	15,00
1479578	2621-1684	18,0	2,50	37,0	112,0	14,00	11,20	15,50
1234892	2621-1668	18,0	1,50	37,0	112,0	14,00	11,20	16,50
1234893	2621-1732	20,0	2,50	37,0	112,0	14,00	11,20	17,50
1335601	2621-1724	20,0	2,00	37,0	112,0	14,00	11,20	18,00
1583250	2621-1820	24,0	3,00	45,0	130,0	18,00	14,00	21,00
1152406	2621-1812	24,0	2,00	45,0	130,0	18,00	14,00	22,00
1583252	2621-1874	27,0	1,50	37,0	127,0	20,00	16,00	25,50
1240404	2621-1960	30,0	3,50	48,0	138,0	20,00	16,00	26,50
1335602	2621-1944	30,0	2,00	37,0	127,0	20,00	16,00	28,00

Метчики машинные для глухих отверстий с винтовыми канавками, М

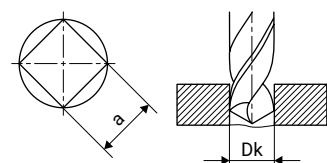
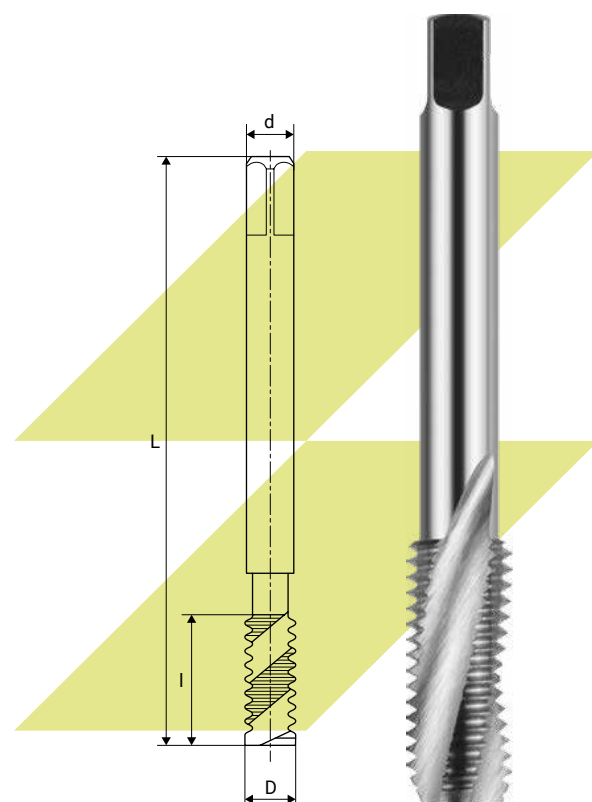
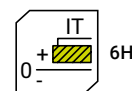
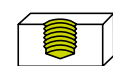

Артикул	Обозначение по ГОСТ	D, мм	P, мм	I, мм	L, мм	d, мм	a, мм	Dk, мм
1185052	—	2,0	0,40	16,0	42,0	2,50	2,00	1,60
1240714	—	2,5	0,45	14,0	46,0	3,00	2,24	2,05
1185053	2620-3373	3,0	0,50	11,0	48,0	2,24	1,80	2,50
1185476	2620-3389	4,0	0,70	13,0	53,0	3,15	2,50	3,30
1185054	2620-3397	5,0	0,80	16,0	58,0	4,00	3,15	4,20
1185055	2620-3405	6,0	1,00	19,0	66,0	4,50	3,55	5,00
1185056	2620-3417	8,0	1,25	22,0	72,0	6,30	5,00	6,80
1417804	2620-3449	10,0	1,00	20,0	76,0	8,00	6,30	9,00
1585150	2620-3445	10,0	1,25	20,0	76,0	8,00	6,30	8,75
1185058	2620-3441	10,0	1,50	24,0	80,0	8,00	6,30	8,50
1585151	2620-3481	12,0	1,00	24,0	80,0	9,00	7,10	11,00
1417805	2620-3477	12,0	1,25	24,0	84,0	9,00	7,10	10,80

Артикул	Обозначение по ГОСТ	D, мм	P, мм	I, мм	L, мм	d, мм	a, мм	Dk, мм
1585152	2620-3473	12,0	1,50	29,0	89,0	9,00	7,10	10,50
1185059	2620-3469	12,0	1,75	29,0	89,0	9,00	7,10	10,20
1585153	2620-3497	14,0	1,00	25,0	84,0	11,20	9,00	13,00
1585154	2620-3493	14,0	1,25	25,0	90,0	11,20	9,00	12,75
1585155	2620-3489	14,0	1,50	30,0	95,0	11,20	9,00	12,50
1585156	2620-3485	14,0	2,00	30,0	95,0	11,20	9,00	12,00
1585157	2620-3509	16,0	1,00	29,0	90,0	12,50	10,00	15,00
1585158	2620-3505	16,0	1,50	32,0	102,0	12,50	10,00	14,50
1585159	2620-3501	16,0	2,00	32,0	102,0	12,50	10,00	14,00
1585160	2620-3529	18,0	1,00	29,0	95,0	14,00	11,20	17,00
1585161	2620-3525	18,0	1,50	29,0	104,0	14,00	11,20	16,50
1585162	2620-3521	18,0	2,00	37,0	112,0	14,00	11,20	16,00
1585163	2620-3517	18,0	2,50	37,0	112,0	14,00	11,20	15,50
1585164	2620-3545	20,0	1,00	29,0	102,0	14,00	11,20	19,00
1585165	2620-3541	20,0	1,50	29,0	104,0	14,00	11,20	18,50
1585166	2620-3537	20,0	2,00	37,0	112,0	14,00	11,20	18,00
1585167	2620-3533	20,0	2,50	37,0	112,0	14,00	11,20	17,50

Нарезание и накатывание резьбы

Нарезание и накатывание резьбы

Метчики машинные и ручные, комплект из 2-х штук, М

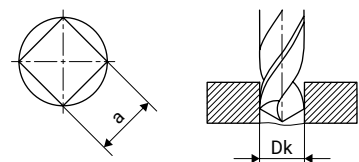
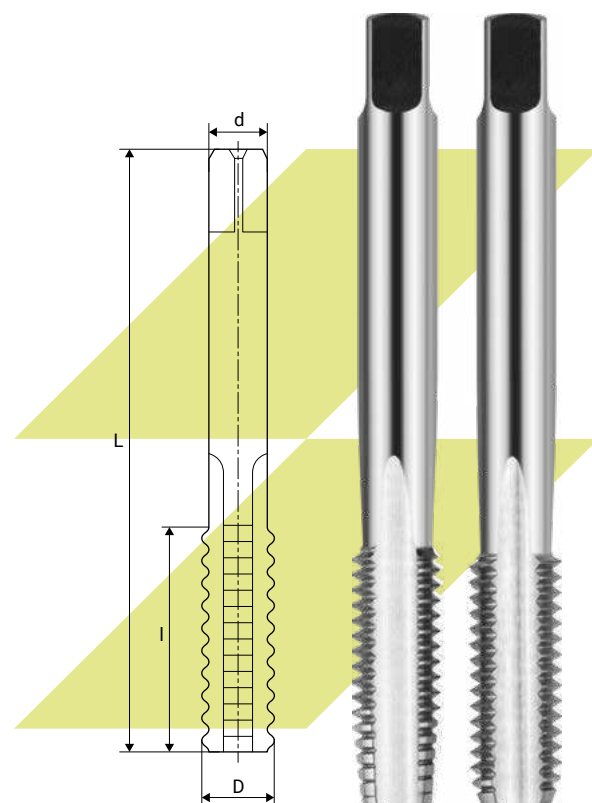
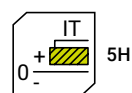
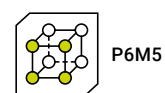
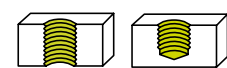

Артикул	Обозначение по ГОСТ	D, мм	P, мм	I, мм	L, мм	d, мм	a, мм	Dk, мм
1253777	2620-1015/1013	2,0	0,40	8,0	41,0	2,50	2,00	1,60
1253778	2620-1047/1045	2,5	0,45	9,5	44,5	2,80	2,24	2,05
1234637	2621-2405/2403	3,0	0,50	11,0	48,0	2,24	1,80	2,50
1181243	2621-2429/2431	4,0	0,70	13,0	53,0	3,15	2,50	3,30
1181244	2621-2461/2463	5,0	0,80	16,0	58,0	4,00	3,15	4,20
1181245	2621-2485/2487	6,0	1,00	19,0	66,0	4,00	3,15	5,00
1178218	2621-2533/2535	8,0	1,25	22,0	72,0	6,30	5,00	6,80
1181246	2621-2541/2543	8,0	1,00	22,0	72,0	6,30	5,00	7,00
1178217	2621-2597/2599	10,0	1,50	24,0	80,0	8,00	6,30	8,50
1181247	2621-2613/2615	10,0	1,00	24,0	80,0	8,00	6,30	9,00
1181251	2621-1519/1517	12,0	1,75	29,0	89,0	9,00	7,10	10,20
1181250	2621-1511/1509	12,0	1,50	29,0	89,0	9,00	7,10	10,50

Артикул	Обозначение по ГОСТ	D, мм	P, мм	I, мм	L, мм	d, мм	a, мм	Dk, мм
1181249	2621-1503/1501	12,0	1,25	29,0	89,0	9,00	7,10	10,80
1253779	2621-1495/1493	12,0	1,00	24,0	84,0	9,00	7,10	11,00
1181253	2621-1567/1565	14,0	2,00	30,0	95,0	11,20	9,00	12,00
1181252	2621-1559/1557	14,0	1,50	30,0	95,0	11,20	9,00	12,50
1234635	2621-1543/1541	14,0	1,00	24,0	84,0	11,20	9,00	13,00
1253781	2621-1615/1613	16,0	1,50	32,0	102,0	12,50	10,00	14,50
1253783	2621-1671/1669	18,0	1,50	37,0	112,0	14,00	11,20	16,50
1253782	2621-1663/1661	18,0	1,00	29,0	95,0	14,00	11,20	17,00
1253785	2621-1719/1717	20,0	1,50	37,0	112,0	14,00	11,20	18,50
1253784	2621-1711/1709	20,0	1,00	29,0	102,0	14,00	11,20	19,00
1234636	2621-1759/1757	22,0	1,00	29,0	112,0	16,00	12,50	21,00
1253786	2621-1807/1805	24,0	1,50	45,0	130,0	18,00	14,00	22,50
1253787	2621-1877/1875	27,0	1,50	37,0	127,0	20,00	16,00	25,50

Нарезание и накатывание резьбы

Нарезание и накатывание резьбы

Метчики машинные и ручные, комплект из 2-х штук, М

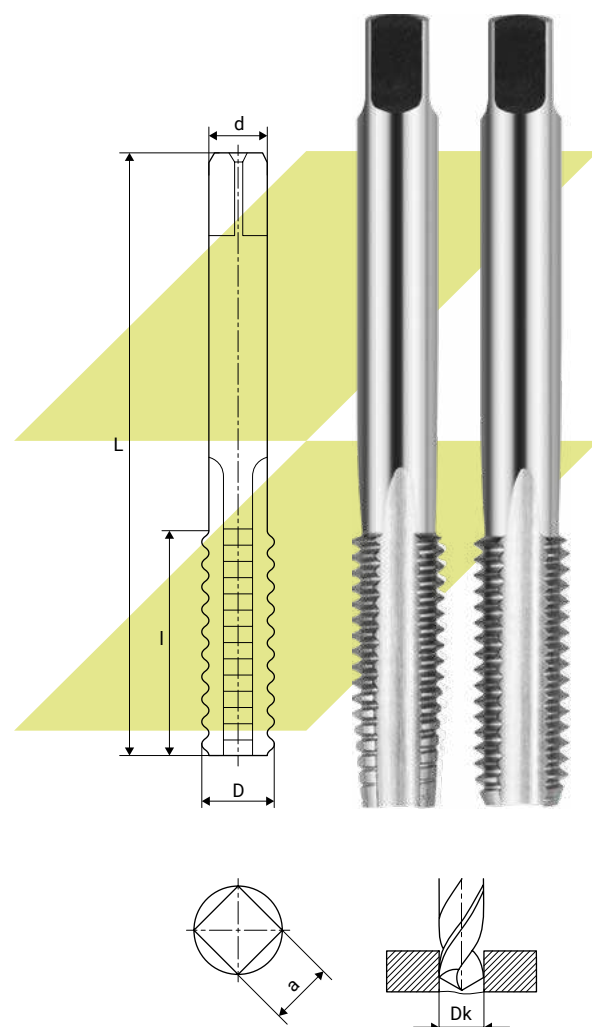
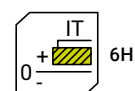
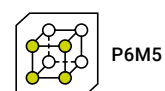
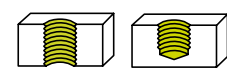



Артикул	Обозначение по ГОСТ	D, мм	P, мм	I, мм	L, мм	d, мм	a, мм	Dk, мм
1151744	2620-3725/3723	1,0	0,25	5,5	38,5	2,50	2,00	0,75
1178418	2620-3737/3735	1,1	0,25	5,5	38,5	2,50	2,00	0,85
1151748	2620-3749/3747	1,2	0,25	5,5	38,5	2,50	2,00	0,95
1151753	2620-3761/3759	1,4	0,30	7,0	40,0	2,50	2,00	1,10
1151758	2620-3773/3771	1,6	0,35	8,0	41,0	2,50	2,00	1,25
1178419	2620-3785/3783	1,7	0,35	8,0	41,0	2,50	2,00	1,30
1151764	—	1,8	0,35	8,0	41,0	2,50	2,00	1,45
1151777	2620-1015/1013	2,0	0,40	8,0	41,0	2,50	2,00	1,60
1178420	2620-1007/1005	2,0	0,25	8,0	41,0	2,50	2,00	1,75
1343484	2620-1023/1021	2,2	0,25	9,5	44,5	2,80	2,24	1,95
1151792	2620-1047/1045	2,5	0,45	9,5	44,5	2,80	2,24	2,05
1220785	2620-1039/1037	2,5	0,35	9,5	44,5	2,80	2,24	2,15

Артикул	Обозначение по ГОСТ	D, мм	P, мм	I, мм	L, мм	d, мм	a, мм	Dk, мм
1293061	2621-2405/2403	3,0	0,50	11,0	48,0	2,24	1,80	2,50
1151800	2621-2409/2411	3,0	0,35	11,0	48,0	2,24	1,80	2,65
1178715	2621-2417/2415	3,5	0,60	13,0	50,0	2,50	2,00	2,90
1151861	2621-2429/2431	4,0	0,70	13,0	53,0	3,15	2,50	3,30
1479432	2621-2429/2431	4,0	0,70	13,0	53,0	3,15	2,50	3,30
1289557	2621-2437/2439	4,0	0,50	13,0	53,0	3,15	2,50	3,50
1582266	2621-2445/22447	4,5	0,75	13,0	53,0	3,55	2,80	3,70
1417905	2621-2437/2439	4,5	0,50	13,0	53,0	3,55	2,80	3,50
1151904	2621-2461/2463	5,0	0,80	16,0	58,0	4,00	3,15	4,20
1234866	2621-2477/2479	5,5	0,50	17,0	62,0	4,00	3,15	5,00
1151953	2621-2485/2487	6,0	1,00	19,0	66,0	4,00	3,15	5,00
1343027	2621-1151/1149	6,0	0,75	19,0	66,0	6,30	5,00	5,20
1479434	2621-2493/2495	6,0	0,75	19,0	66,0	4,00	3,15	5,20
1185632	2621-2501/2503	6,0	0,50	19,0	66,0	4,00	3,15	5,50
1178717	2621-2509/2511	7,0	1,00	19,0	66,0	5,60	4,50	6,00
1234867	2621-2517/2519	7,0	0,75	19,0	66,0	5,60	4,50	6,20
1240359	2621-2525/2527	7,0	0,50	19,0	66,0	5,60	4,50	6,50
1343029	—	8,0	1,50	22,0	72,0	6,30	5,00	6,50
1152016	2621-2533/2535	8,0	1,25	22,0	72,0	6,30	5,00	6,80
1178422	2621-2541/2543	8,0	1,00	22,0	72,0	6,30	5,00	7,00
1185057	2621-2549/2551	8,0	0,75	19,0	66,0	6,30	5,00	7,20
1185633	2621-2557/2559	8,0	0,50	19,0	66,0	6,30	5,00	7,50
1178424	2621-2565/2567	9,0	1,25	22,0	72,0	7,10	5,60	7,80
1479570	2621-2573/2575	9,0	1,00	22,0	72,0	7,10	5,60	8,00
1152029	2621-2581/2583	9,0	0,75	19,0	66,0	7,10	5,60	8,20
1152091	2621-2597/2599	10,0	1,50	24,0	80,0	8,00	6,30	8,50
1260103	2621-2605/2607	10,0	1,25	24,0	80,0	8,00	6,30	8,80
1178425	2621-2613/2615	10,0	1,00	24,0	80,0	8,00	6,30	9,00
1479571	2621-2621/2623	10,0	0,75	19,0	66,0	8,00	6,30	9,20
1583243	2621-2629/2631	10,0	0,50	19,0	66,0	8,00	6,30	9,50
1178721	2621-1471/1469	11,0	1,50	25,0	85,0	8,00	6,30	9,50
1178433	2621-1463/1461	11,0	1,00	24,0	80,0	8,00	6,30	10,00
1178432	2621-1455/1453	11,0	0,75	19,0	80,0	8,00	6,30	10,20
1178431	2621-1447/1445	11,0	0,50	19,0	80,0	8,00	6,30	10,50
1178441	2621-1519/1517	12,0	1,75	29,0	89,0	9,00	7,10	10,20
1178438	2621-1511/1509	12,0	1,50	29,0	89,0	9,00	7,10	10,50
1178436	2621-1503/1501	12,0	1,25	29,0	89,0	9,00	7,10	10,80
1337547	2621-1495/1493	12,0	1,00	24,0	84,0	9,00	7,10	11,00
1178435	2621-1479/1477	12,0	0,50	19,0	80,0	9,00	7,10	11,50

Нарезание и накатывание резьбы

Нарезание и накатывание резьбы

Артикул		Обозначение по ГОСТ	D, мм	P, мм	I, мм	L, мм	d, мм	a, мм	Dk, мм
1583248	●	—	13,0	1,00	24,0	84,0	9,00	7,10	12,00
1178725	●	2621-1567/1565	14,0	2,00	30,0	95,0	11,20	9,00	12,00
1178448	●	2621-1559/1557	14,0	1,50	30,0	95,0	11,20	9,00	12,50
1152194	●	2621-1551/1549	14,0	1,25	30,0	95,0	11,20	9,00	12,80
1261391	●	2621-1543/1541	14,0	1,00	24,0	84,0	11,20	9,00	13,00
1152183	●	2621-1535/1533	14,0	0,75	19,0	84,0	11,20	9,00	13,20
1178444	●	2621-1527/1525	14,0	0,50	19,0	80,0	11,20	9,00	13,50
1178452	●	2621-1583/1581	15,0	1,50	30,0	95,0	11,20	9,00	13,50
1152273	●	2621-1623/1621	16,0	2,00	32,0	102,0	12,50	10,00	14,00
1240360	●	2621-1615/1613	16,0	1,50	32,0	102,0	12,50	10,00	14,50
1178455	●	—	16,0	1,25	32,0	102,0	12,50	10,00	14,75
1152235	●	2621-1599/1597	16,0	0,75	20,0	90,0	12,50	10,00	15,25
1152232	●	2621-1591/1589	16,0	0,50	19,0	80,0	12,50	10,00	15,50
1178460	●	2621-1639/1637	17,0	1,50	32,0	102,0	12,50	10,00	15,50
1178459	●	2621-1631/1629	17,0	1,00	29,0	90,0	12,50	10,00	16,00
1337551	●	2621-1687/1685	18,0	2,50	37,0	112,0	14,00	11,20	15,50
1152303	●	2621-1679/1677	18,0	2,00	37,0	112,0	14,00	11,20	16,00
1178463	●	2621-1671/1669	18,0	1,50	37,0	112,0	14,00	11,20	16,50
1152290	●	2621-1671/1669	18,0	1,25	37,0	112,0	14,00	11,20	16,75
1337550	●	2621-1663/1661	18,0	1,00	37,0	95,0	14,00	11,20	17,00
1178727	●	2621-1655/1653	18,0	0,75	20,0	95,0	14,00	11,20	17,25
1178461	●	2621-1647/1645	18,0	0,50	19,0	80,0	14,00	11,20	17,50
1178219	●	2621-1735/1733	20,0	2,50	37,0	112,0	14,00	11,20	17,50
1178472	●	2621-1727/1725	20,0	2,00	37,0	112,0	14,00	11,20	18,00
1178469	●	2621-1719/1717	20,0	1,50	37,0	112,0	14,00	11,20	18,50
1293029	●	2621-1703/1701	20,0	0,75	20,0	102,0	14,00	11,20	19,25
1178467	●	2621-1695/1693	20,0	0,50	20,0	90,0	14,00	11,20	19,50
1178735	●	2621-1783/1781	22,0	2,50	38,0	118,0	16,00	12,50	19,50
1178734	●	2621-1775/1773	22,0	2,00	38,0	118,0	16,00	12,50	20,00
1178477	●	2621-1767/1765	22,0	1,50	38,0	118,0	16,00	12,50	20,50
1178476	●	2621-1759/1757	22,0	1,00	29,0	112,0	16,00	12,50	21,00
1178475	●	2621-1751/1749	22,0	0,75	20,0	112,0	16,00	12,50	21,20
1178474	●	2621-1743/1741	22,0	0,50	20,0	90,0	16,00	12,50	21,50
1152411	●	2621-1821/1819	24,0	3,00	45,0	130,0	18,00	14,00	21,00
1254909	●	—	24,0	2,50	45,0	130,0	18,00	14,00	21,50
1240361	●	2621-1815/1813	24,0	2,00	35,0	120,0	18,00	14,00	22,00
1337438	●	2621-1807/1805	24,0	1,50	35,0	120,0	18,00	14,00	22,50
1178736	●	2621-1799/1797	24,0	1,00	33,0	113,0	18,00	14,00	23,00
1178479	●	2621-1791/1789	24,0	0,75	25,0	113,0	18,00	14,00	23,20

Артикул		Обозначение по ГОСТ	D, мм	P, мм	I, мм	L, мм	d, мм	a, мм	Dk, мм
1178486	●	2621-1845/1843	25,0	2,00	35,0	120,0	18,00	14,00	23,00
1152416	●	2621-1837/1835	25,0	1,50	35,0	120,0	18,00	14,00	23,50
1181242	●	2621-1829/1827	25,0	1,00	33,0	113,0	18,00	14,00	24,00
1178487	●	2621-1853/1851	26,0	1,50	35,0	120,0	18,00	14,00	24,50
1240362	●	2621-1885/1883	27,0	2,00	37,0	127,0	20,00	16,00	25,00
1178737	●	2621-1877/1875	27,0	1,50	37,0	127,0	20,00	16,00	25,50
1179987	●	2621-1869/1867	27,0	1,00	33,0	120,0	20,00	16,00	26,00
1178488	●	2621-1861/1859	27,0	0,75	25,0	120,0	20,00	16,00	26,25
1178493	●	2621-1915/1913	28,0	2,00	37,0	127,0	20,00	16,00	26,00
1152454	●	2621-1907/1905	28,0	1,50	37,0	127,0	20,00	16,00	26,50
1178492	●	2621-1899/1897	28,0	1,00	33,0	120,0	20,00	16,00	27,00
1178502	●	2621-1959/1957	30,0	3,50	48,0	138,0	20,00	16,00	26,50
1178498	●	2621-1953/1951	30,0	3,00	48,0	138,0	20,00	16,00	27,00
1178496	●	2621-1947/1945	30,0	2,00	37,0	127,0	20,00	16,00	28,00
1178495	●	2621-1939/1937	30,0	1,50	37,0	127,0	20,00	16,00	28,50
1152460	●	2621-1931/1929	30,0	1,00	33,0	120,0	20,00	16,00	29,00
1178503	●	2621-1975/1973	32,0	2,00	37,0	127,0	22,40	18,00	30,00
1152488	●	2621-1967/1965	32,0	1,50	37,0	137,0	22,40	18,00	30,50
1152517	●	2621-2019/2017	33,0	3,50	51,0	151,0	22,40	18,00	29,50
1152513	●	2621-2013/2011	33,0	3,00	51,0	151,0	22,40	18,00	30,00
1261535	●	2621-2007/2005	33,0	2,00	37,0	137,0	22,40	18,00	31,00
1331240	●	2621-1999/1997	33,0	1,50	37,0	137,0	22,40	18,00	31,50
1178504	●	2621-1983/1981	33,0	0,75	25,0	130,0	22,40	18,00	32,25
1178505	●	2621-2027/2025	35,0	1,50	39,0	144,0	25,00	20,00	33,50
1152546	●	2621-2063/2061	36,0	4,00	57,0	162,0	25,00	20,00	32,00
1417068	●	2621-2057/2055	36,0	3,00	57,0	162,0	25,00	20,00	33,00
1419549	●	2621-2051/2049	36,0	2,00	39,0	144,0	25,00	20,00	34,00
1152521	●	2621-2035/2033	36,0	1,00	32,0	130,0	25,00	20,00	35,00
1178507	●	2621-2071/2069	38,0	1,50	39,0	151,0	28,00	22,40	36,50
1152568	●	2621-2101/2099	39,0	3,00	60,0	170,0	28,00	22,40	36,00
1419535	●	2621-2095/2093	39,0	2,00	39,0	149,0	28,00	22,40	37,00
1419534	●	2621-2087/2085	39,0	1,50	39,0	149,0	28,00	22,40	37,50
1152553	●	2621-2079/2077	39,0	1,00	37,0	144,0	28,00	22,40	38,00
1178511	●	2621-2129/2127	40,0	3,00	60,0	170,0	28,00	22,40	37,00
1178510	●	2621-2123/2121	40,0	2,00	39,0	149,0	28,00	22,40	38,00
1178509	●	2621-2115/2113	40,0	1,50	39,0	149,0	28,00	22,40	38,50
1377927	●	—	40,0	1,00	39,0	149,0	28,00	22,40	39,00
1152600	●	2621-2171/2169	42,0	4,50	60,0	170,0	28,00	22,40	37,50
1178514	●	2621-2165/2165	42,0	4,00	60,0	170,0	28,00	22,40	38,00

Артикул	Обозначение по ГОСТ	D, мм	P, мм	l, мм	L, мм	d, мм	a, мм	Dk, мм
1178513	2621-2159/2157	42,0	3,00	60,0	170,0	28,00	22,40	39,00
1178512	2621-2153/2151	42,0	2,00	39,0	149,0	28,00	22,40	40,00
1583255	2621-2145/2143	42,0	1,50	39,0	149,0	28,00	22,40	40,50
1418148	2621-2207/2205	45,0	4,00	67,0	187,0	31,50	25,00	41,00
1337558	2621-2201/2199	45,0	3,00	67,0	187,0	31,50	25,00	42,00
1152615	2621-2195/2193	45,0	2,00	45,0	165,0	31,50	25,00	43,00
1178515	2621-2179/2177	45,0	1,00	37,0	151,0	31,50	25,00	44,00
1178520	2621-2255/2253	48,0	5,00	67,0	187,0	31,50	25,00	43,00
1417639	2621-2249/2247	48,0	4,00	67,0	187,0	31,50	25,00	44,00
1178519	2621-2243/2241	48,0	3,00	67,0	187,0	31,50	25,00	45,00
1178518	2621-2237/2235	48,0	2,00	45,0	165,0	31,50	25,00	46,00
1178517	2621-2221/2219	48,0	1,00	37,0	151,0	31,50	25,00	47,00
1178523	2621-2277/2275	50,0	3,00	67,0	187,0	31,50	25,00	47,00
1178521	2621-2271/2269	50,0	2,00	45,0	165,0	31,50	25,00	48,00
1152657	2621-2263/2261	50,0	1,50	45,0	165,0	31,50	25,00	48,50
1175605	2621-2293/2291	52,0	1,50	45,0	175,0	35,50	28,00	50,50
1178524	2621-2285/2283	52,0	1,00	37,0	165,0	35,50	28,00	51,00
1378765	—	56,0	5,50	70,0	200,0	35,50	28,00	50,00
1289433	—	56,0	4,00	70,0	200,0	35,50	28,00	52,00
1289432	—	56,0	3,00	70,0	200,0	35,50	28,00	53,00
1152680	—	56,0	2,00	45,0	175,0	35,50	28,00	54,00
1240363	—	56,0	1,50	45,0	175,0	35,50	28,00	54,50
1417620	—	60,0	4,00	77,0	220,0	40,00	31,50	56,00
1252612	—	60,0	3,00	77,0	210,0	40,00	31,50	57,00
1178526	—	60,0	2,00	52,0	190,0	40,00	31,50	58,00
1240365	—	64,0	6,00	79,0	224,0	40,00	31,50	58,00
1240364	—	64,0	4,00	79,0	224,0	40,00	31,50	60,00
1178528	—	64,0	3,00	79,0	224,0	40,00	31,50	61,00
1234880	—	64,0	2,00	55,0	190,0	40,00	31,50	62,00
1178527	—	64,0	1,50	55,0	190,0	40,00	31,50	62,50
1179991	—	68,0	1,50	55,0	200,0	45,00	35,50	66,50
1417621	—	72,0	2,00	80,0	205,0	45,00	35,50	70,00
1417622	—	76,0	3,00	80,0	245,0	50,00	40,00	73,00

Метчики машинные и ручные, комплект из 2-х штук, М

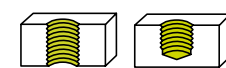

ГОСТ 3266-81



P6M5

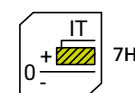

IT 7H

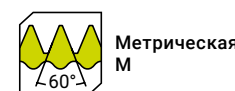

Метрическая М



Машинно-ручные



Правое

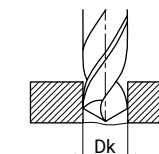
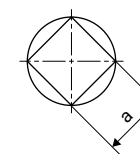
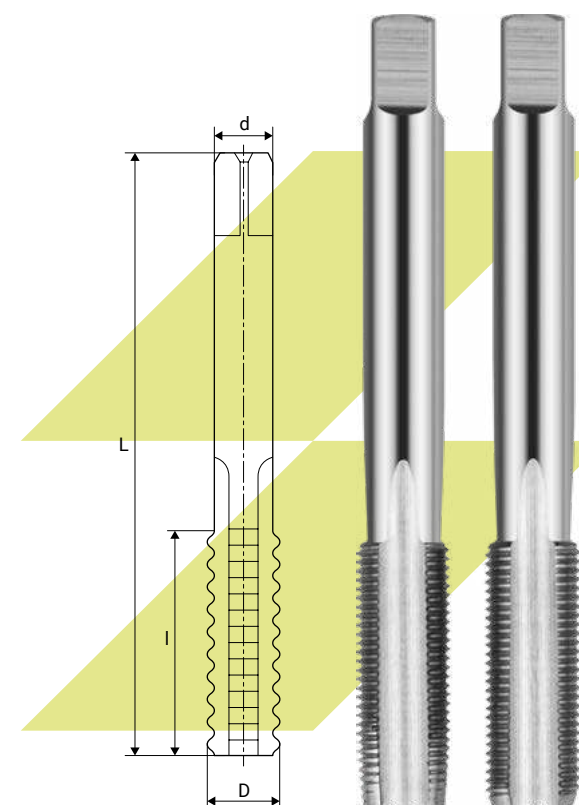

Артикул	Обозначение по ГОСТ	D, мм	P, мм	l, мм	L, мм	d, мм	a, мм	Dk, мм
1179978	2620-1047/1045	2,5	0,45	9,5	44,5	2,80	2,24	2,05
1179979	2621-2429/2431	4,0	0,70	13,0	53,0	3,15	2,50	3,30
1179980	2621-2461/2463	5,0	0,80	16,0	58,0	4,00	3,15	4,20
1179981	2621-2485/2487	6,0	1,00	19,0	66,0	4,00	3,15	5,00
1179982	2621-2533/2535	8,0	1,25	22,0	72,0	6,30	5,00	6,80
1179983	2621-2597/2599	10,0	1,50	24,0	80,0	8,00	6,30	8,50
1253608	2621-2613/2615	10,0	1,00	24,0	80,0	8,00	6,30	9,00
1253609	2621-1495/1493	12,0	1,00	24,0	84,0	9,00	7,10	11,00
1253612	2621-1567/1565	14,0	2,00	30,0	95,0	11,20	9,00	12,00
1253611	2621-1559/1557	14,0	1,50	30,0	95,0	11,20	9,00	12,50
1253610	2621-1543/1541	14,0	1,00	24,0	84,0	11,20	9,00	13,00
1179986	2621-1623/1621	16,0	2,00	32,0	102,0	12,50	10,00	14,00

Нарезание и накатывание резьбы

Нарезание и накатывание резьбы

Артикул	Обозначение по ГОСТ	D, мм	P, мм	I, мм	L, мм	d, мм	a, мм	Dk, мм
1179985	2621-1607/1605	16,0	1,00	29,0	90,0	12,50	10,00	15,00
1253619	2621-1687/1685	18,0	2,50	37,0	112,0	14,00	11,20	15,50
1253618	2621-1671/1669	18,0	1,50	37,0	112,0	14,00	11,20	16,50
1253616	2621-1663/1661	18,0	1,00	37,0	95,0	14,00	11,20	17,00
1253621	2621-1783/1781	22,0	2,50	38,0	118,0	16,00	12,50	19,50
1252628	2621-1821/1819	24,0	3,00	45,0	130,0	18,00	14,00	21,00
1253622	2621-1891/1889	27,0	3,00	45,0	135,0	20,00	16,00	24,00
1179988	2621-1877/1875	27,0	1,50	37,0	127,0	20,00	16,00	25,50
1252629	2621-1959/1957	30,0	3,50	48,0	138,0	20,00	16,00	26,50
1253625	2621-1939/1937	30,0	1,50	37,0	127,0	20,00	16,00	28,50
1253627	2621-2063/2061	36,0	4,00	57,0	162,0	25,00	20,00	32,00
1179989	2621-2043/2041	36,0	1,50	39,0	144,0	25,00	20,00	34,50
1253628	2621-2107/2105	39,0	4,00	60,0	170,0	28,00	22,40	35,00
1253629	2621-2171/2169	42,0	4,50	60,0	170,0	28,00	22,40	37,50
1253630	2621-2159/2157	42,0	3,00	60,0	170,0	28,00	22,40	39,00
1179990	2621-2221/2219	48,0	1,00	37,0	151,0	31,50	25,00	47,00
1178530	—	60,0	1,50	55,0	190,0	40,00	31,50	58,50
1178531	—	72,0	1,50	55,0	200,0	45,00	35,50	70,50

Метчики машинные и ручные, комплект из 2-х штук, М

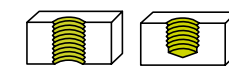

ГОСТ 3266-81

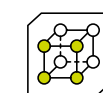

P6M5

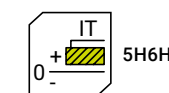

IT 5H6H



Метрическая М



Машинно-ручные



Правое

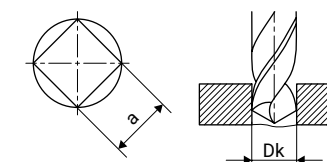
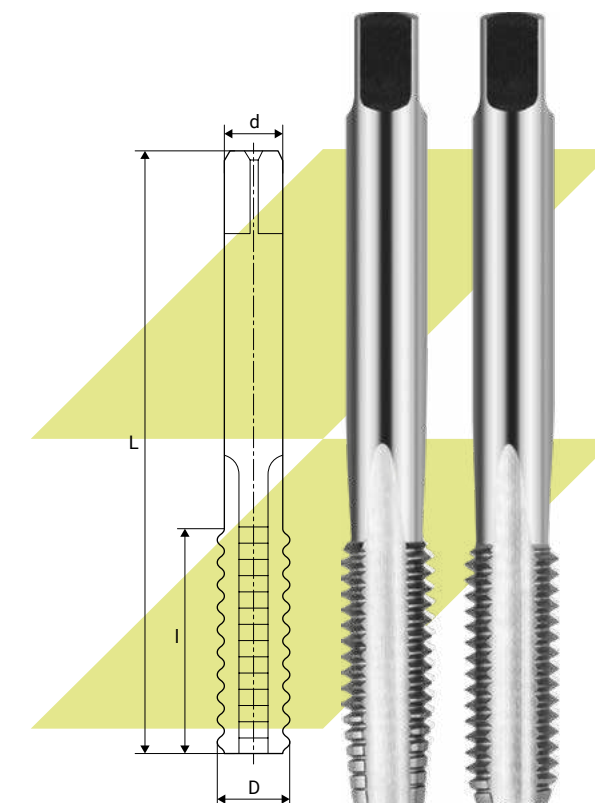

Артикул	Обозначение по ГОСТ	D, мм	P, мм	I, мм	L, мм	d, мм	a, мм	Dk, мм
1240366	2621-2405/2403	3,0	0,50	11,0	48,0	2,24	1,80	2,50
1240367	2621-2429/2431	4,0	0,70	13,0	53,0	3,15	2,50	3,30
1240368	2621-2461/2463	5,0	0,80	16,0	58,0	4,00	3,15	4,20
1240369	2621-2485/2487	6,0	1,00	19,0	66,0	4,00	3,15	5,00
1240370	2621-2533/2535	8,0	1,25	22,0	72,0	6,30	5,00	6,80
1240371	2621-2597/2599	10,0	1,50	24,0	80,0	8,00	6,30	8,50
1240372	2621-1519/2517	12,0	1,75	29,0	89,0	9,00	7,10	10,20
1240373	2621-1567/1565	14,0	2,00	30,0	95,0	11,20	9,00	12,00
1240374	2621-1623/1621	16,0	2,00	32,0	102,0	12,50	10,00	14,00

Метчики машинные и ручные, комплект из 2-х штук, М

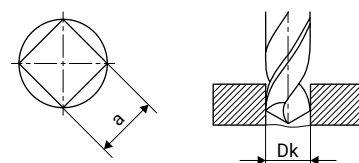
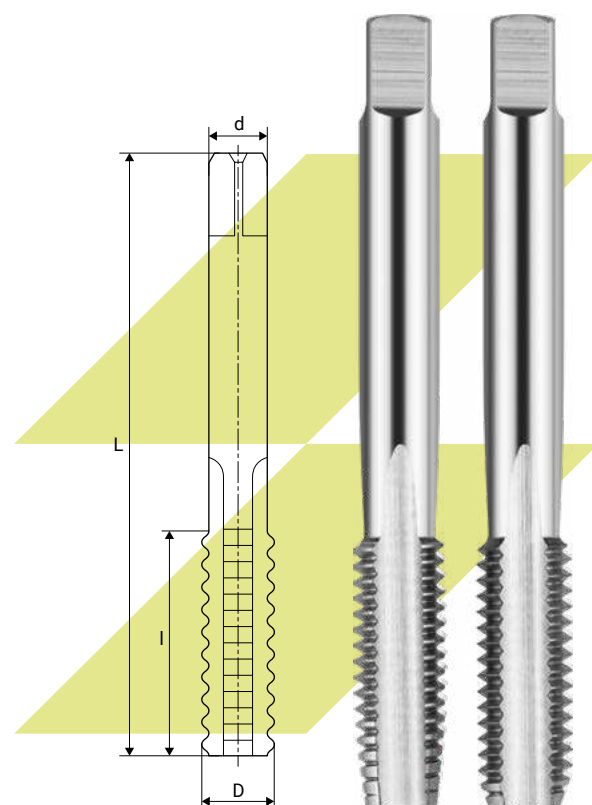
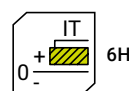
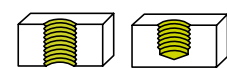

Артикул	Обозначение по ГОСТ	D, мм	P, мм	I, мм	L, мм	d, мм	a, мм	Dk, мм
1325809	2620-3749/3747	1,2	0,25	5,5	38,5	2,50	2,00	0,95
1325810	2620-1015/1013	2,0	0,40	8,0	41,0	2,50	2,00	1,60
1325811	2620-1047/1045	2,5	0,45	9,5	44,5	2,80	2,24	2,05
1325812	2621-2405/2403	3,0	0,50	11,0	48,0	2,24	1,80	2,50
1325813	2621-2429/2431	4,0	0,70	13,0	53,0	3,15	2,50	3,30
1325814	2621-2461/2463	5,0	0,80	16,0	58,0	4,00	3,15	4,20
1325815	2621-2485/2487	6,0	1,00	19,0	66,0	4,00	3,15	5,00
1325819	2621-2533/2535	8,0	1,25	22,0	72,0	6,30	5,00	6,80
1325818	2621-2541/2543	8,0	1,00	22,0	72,0	6,30	5,00	7,00
1325817	2621-2549/2551	8,0	0,75	19,0	66,0	6,30	5,00	7,20
1325816	2621-2557/2559	8,0	0,50	19,0	66,0	6,30	5,00	7,50
1377459	2621-2581/2583	9,0	0,75	19,0	66,0	7,10	5,60	8,20

Артикул	Обозначение по ГОСТ	D, мм	P, мм	I, мм	L, мм	d, мм	a, мм	Dk, мм
1325824	2621-2597/2599	10,0	1,50	24,0	80,0	8,00	6,30	8,50
1325823	2621-2605/2607	10,0	1,25	24,0	80,0	8,00	6,30	8,80
1325822	2621-2613/2615	10,0	1,00	24,0	80,0	8,00	6,30	9,00
1325821	2621-2621/2623	10,0	0,75	19,0	66,0	8,00	6,30	9,20
1325820	2621-2629/2631	10,0	0,50	19,0	66,0	8,00	6,30	9,50
1325829	2621-1519/1517	12,0	1,75	29,0	89,0	9,00	7,10	10,20
1325828	2621-1503/1501	12,0	1,25	29,0	89,0	9,00	7,10	10,80
1325827	2621-1495/1493	12,0	1,00	24,0	84,0	9,00	7,10	11,00
1325826	2621-1487/1485	12,0	0,75	19,0	80,0	9,00	7,10	11,20
1325825	2621-1479/1477	12,0	0,50	19,0	80,0	9,00	7,10	11,50
1325833	2621-1567/1565	14,0	2,00	30,0	95,0	11,20	9,00	12,00
1325832	2621-1559/1557	14,0	1,50	30,0	95,0	11,20	9,00	12,50
1325831	2621-1551/1549	14,0	1,25	30,0	95,0	11,20	9,00	12,80
1325830	2621-1543/1541	14,0	1,00	24,0	84,0	11,20	9,00	13,00
1325836	2621-1623/1621	16,0	2,00	32,0	102,0	12,50	10,00	14,00
1325835	2621-1615/1613	16,0	1,50	32,0	102,0	12,50	10,00	14,50
1325834	2621-1607/1605	16,0	1,00	29,0	90,0	12,50	10,00	15,00
1171094	2621-1599/1597	16,0	0,75	20,0	90,0	12,50	10,00	15,20
1325842	2621-1687/1685	18,0	2,50	37,0	112,0	14,00	11,20	15,50
1325841	2621-1679/1677	18,0	2,00	37,0	112,0	14,00	11,20	16,00
1325840	2621-1671/1669	18,0	1,50	37,0	112,0	14,00	11,20	16,50
1325839	2621-1663/1661	18,0	1,00	37,0	95,0	14,00	11,20	17,00
1325838	2621-1655/1653	18,0	0,75	20,0	95,0	14,00	11,20	17,20
1325837	2621-1647/1645	18,0	0,50	19,0	80,0	14,00	11,20	17,50
1325846	2621-1735/1733	20,0	2,50	37,0	112,0	14,00	11,20	17,50
1325845	2621-1727/1725	20,0	2,00	37,0	112,0	14,00	11,20	18,00
1325844	2621-1719/1717	20,0	1,50	37,0	112,0	14,00	11,20	18,50
1325843	2621-1711/1709	20,0	1,00	29,0	102,0	14,00	11,20	19,00
1325849	2621-1783/1781	22,0	2,50	38,0	118,0	16,00	12,50	19,50
1325848	2621-1775/1773	22,0	2,00	38,0	118,0	16,00	12,50	20,00
1325847	2621-1767/1765	22,0	1,50	38,0	118,0	16,00	12,50	20,50
1325851	2621-1821/1819	24,0	3,00	45,0	130,0	18,00	14,00	21,00
1152401	2621-1815/1813	24,0	2,00	35,0	120,0	18,00	14,00	22,00
1325850	2621-1807/1805	24,0	1,50	35,0	120,0	18,00	14,00	22,50
1325853	2621-1885/1883	27,0	2,00	37,0	127,0	20,00	16,00	25,00
1325852	2621-1877/1875	27,0	1,50	37,0	127,0	20,00	16,00	25,50
1325857	2621-1959/1957	30,0	3,50	48,0	138,0	20,00	16,00	26,50
1325856	2621-1953/1951	30,0	3,00	48,0	138,0	20,00	16,00	27,00
1325855	2621-1947/1945	30,0	2,00	37,0	127,0	20,00	16,00	28,00

Нарезание и накатывание резьбы

Нарезание и накатывание резьбы

Артикул	Обозначение по ГОСТ	D, мм	P, мм	I, мм	L, мм	d, мм	a, мм	Dk, мм
1325854	2621-1939/1937	30,0	1,50	37,0	127,0	20,00	16,00	28,50
1325861	2621-2019/2017	33,0	3,50	51,0	151,0	22,40	18,00	29,50
1325860	2621-2013/2011	33,0	3,00	51,0	151,0	22,40	18,00	30,00
1325859	2621-2007/2005	33,0	2,00	37,0	137,0	22,40	18,00	31,00
1325858	2621-1999/1997	33,0	1,50	37,0	137,0	22,40	18,00	31,50
1325865	2621-2063/2061	36,0	4,00	57,0	162,0	25,00	20,00	32,00
1325864	2621-2057/2055	36,0	3,00	57,0	162,0	25,00	20,00	33,00
1325863	2621-2051/2049	36,0	2,00	39,0	144,0	25,00	20,00	34,00
1325862	2621-2043/2041	36,0	1,50	39,0	144,0	25,00	20,00	34,50
1237632	2621-2035/2033	36,0	1,00	32,0	130,0	25,00	20,00	35,00
1325868	2621-2101/2099	39,0	3,00	60,0	170,0	28,00	22,40	36,00
1325867	2621-2095/2093	39,0	2,00	39,0	149,0	28,00	22,40	37,00
1325866	2621-2087/2085	39,0	1,50	39,0	149,0	28,00	22,40	37,50

Метчики машинные и ручные, комплект из 2-х штук, M

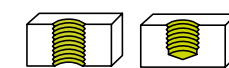

ГОСТ 3266-81



P6M5K5

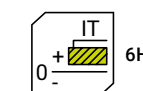

IT 6H

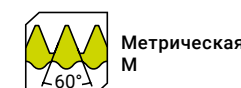

Метрическая M



Машинно-ручные



Правое

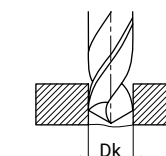
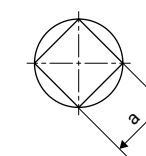
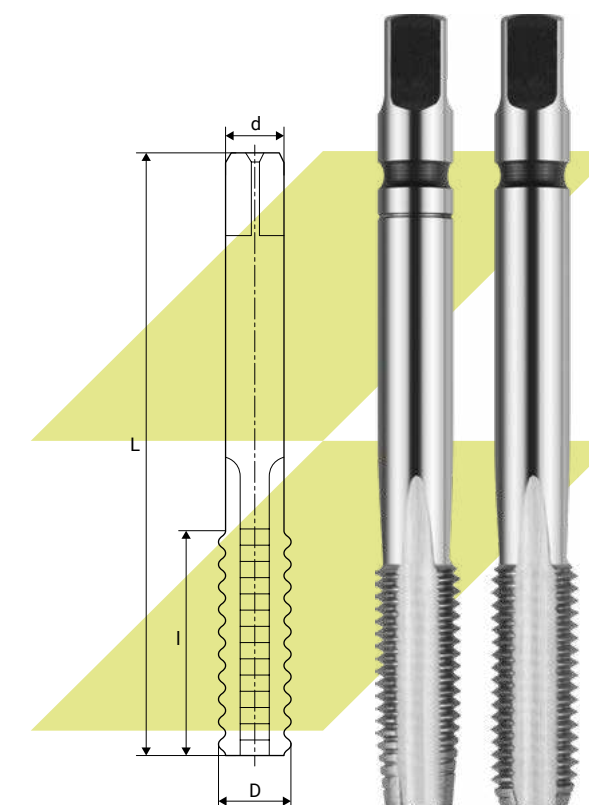

Артикул	Обозначение по ГОСТ	D, мм	P, мм	I, мм	L, мм	d, мм	a, мм	Dk, мм
1441529	2620-1015/1013	2,0	0,40	8,0	41,0	2,50	2,00	1,60
1441530	2620-1047/1045	2,5	0,45	9,5	44,5	2,80	2,24	2,05
1441531	2621-2405/2403	3,0	0,50	11,0	48,0	2,24	1,80	2,50
1441532	2621-2429/2431	4,0	0,70	13,0	53,0	3,15	2,50	3,30
1441533	2621-2461/2463	5,0	0,80	16,0	58,0	4,00	3,15	4,20
1441534	2621-2485/2487	6,0	1,00	19,0	66,0	4,00	3,15	5,00
1441536	2621-2533/2535	8,0	1,25	22,0	72,0	6,30	5,00	6,80
1441535	2621-2541/2543	8,0	1,00	22,0	72,0	6,30	5,00	7,00
1441539	2621-2597/2599	10,0	1,50	24,0	80,0	8,00	6,30	8,50
1441538	2621-2605/2607	10,0	1,25	24,0	80,0	8,00	6,30	8,80
1441537	2621-2613/2615	10,0	1,00	24,0	80,0	8,00	6,30	9,00
1441541	2621-1503/1501	12,0	1,25	29,0	89,0	9,00	7,10	10,80

Артикул	Обозначение по ГОСТ	D, мм	P, мм	I, мм	L, мм	d, мм	a, мм	Dk, мм
1441540	2621-1495/1493	12,0	1,00	24,0	84,0	9,00	7,10	11,00
1441543	2621-1623/1621	16,0	2,00	32,0	102,0	12,50	10,00	14,00
1441542	2621-1607/1605	16,0	1,00	29,0	90,0	12,50	10,00	15,00
1227126	2621-1679/1677	18,0	2,00	37,0	112,0	14,00	11,20	16,00
1441544	2621-1735/1733	20,0	2,50	37,0	112,0	14,00	11,20	17,50
1152340	2621-1719/1717	20,0	1,50	37,0	112,0	14,00	11,20	18,50

Метчики машинные и ручные, комплект из 2-х штук, левые, М

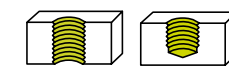

ГОСТ 3266-81

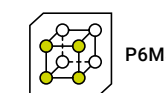

P6M5

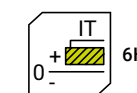

IT 6H



Метрическая М



Машинно-ручные

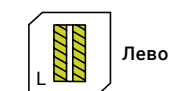

Левое

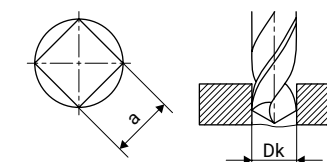
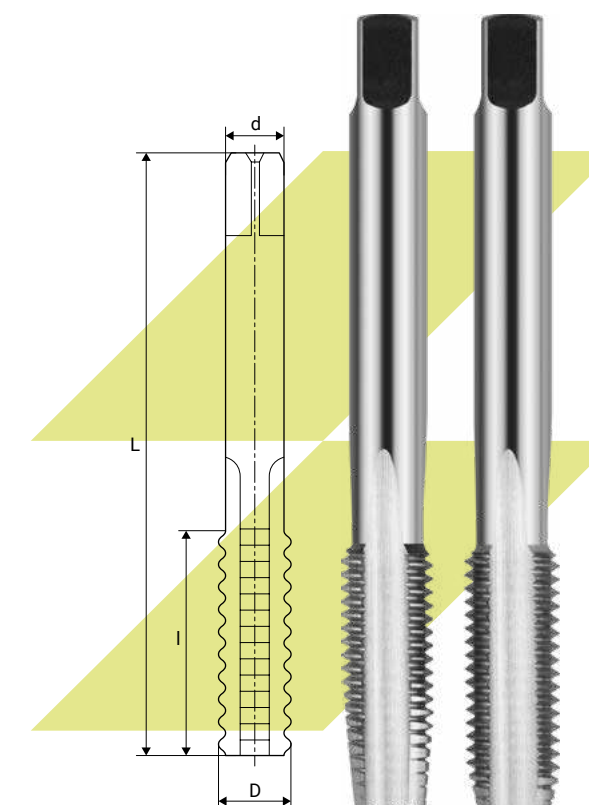

Артикул	Обозначение по ГОСТ	D, мм	P, мм	I, мм	L, мм	d, мм	a, мм	Dk, мм
1256338	2620-1046/1048	2,5	0,45	9,5	44,5	2,80	2,24	2,05
1378365	2621-2664/2666	4,0	0,50	13,0	53,0	3,15	2,50	3,50
1151873	2621-2446/2448	4,5	0,75	13,0	53,0	3,15	2,50	3,80
1151913	2621-2462/2464	5,0	0,80	16,0	58,0	4,00	3,15	4,20
1151962	2621-2486/2488	6,0	1,00	19,0	66,0	4,50	3,55	5,00
1261532	2621-2494/2496	6,0	0,75	19,0	66,0	4,50	3,55	5,20
1240375	2621-2534/2536	8,0	1,25	22,0	72,0	6,30	5,00	6,80
1234868	2621-2542/2544	8,0	1,00	22,0	72,0	6,30	5,00	7,00
1178720	2621-2598/2600	10,0	1,50	24,0	80,0	8,00	6,30	8,50
1178427	2621-2606/2608	10,0	1,25	24,0	80,0	8,00	6,30	8,80
1178426	2621-2614/2616	10,0	1,00	24,0	80,0	8,00	6,30	9,00
1178442	2621-1520/1518	12,0	1,75	29,0	89,0	9,00	7,10	10,20
1178722	2621-1512/1510	12,0	1,50	29,0	89,0	9,00	7,10	10,50

Артикул	Обозначение по ГОСТ	D, мм	P, мм	l, мм	L, мм	d, мм	a, мм	Dk, мм
1583245	2621-1504/1502	12,0	1,25	29,0	89,0	9,00	7,10	10,80
1152116	2621-1488/1486	12,0	0,75	19,0	80,0	9,00	7,10	11,20
1234869	2621-1480/1478	12,0	0,50	19,0	80,0	9,00	7,10	11,50
1417514	2620-1568/1566	14,0	2,00	30,0	95,0	11,20	9,00	12,00
1178450	2621-1568/1566	14,0	2,00	30,0	95,0	11,20	9,00	12,00
1178724	2621-1560/1558	14,0	1,50	30,0	95,0	11,20	9,00	12,50
1178446	2621-1552/1550	14,0	1,25	30,0	95,0	11,20	9,00	12,80
1234871	2621-1544/1542	14,0	1,00	24,0	84,0	11,20	9,00	13,00
1178726	2621-1624/1622	16,0	2,00	32,0	102,0	12,50	10,00	14,00
1178457	2621-1616/1614	16,0	1,50	32,0	102,0	12,50	10,00	14,50
1178453	2621-1608/1606	16,0	1,00	29,0	90,0	12,50	10,00	15,00
1178464	2621-1688/1686	18,0	2,50	37,0	112,0	14,00	11,20	15,50
1178730	2621-1680/1678	18,0	2,00	37,0	112,0	14,00	11,20	16,00
1178728	2621-1672/1670	18,0	1,50	37,0	112,0	14,00	11,20	16,50
1220919	2621-1664/1662	18,0	1,00	37,0	95,0	14,00	11,20	17,00
1220918	2621-1656/1654	18,0	0,75	20,0	95,0	14,00	11,20	17,80
1220917	2621-1648/1646	18,0	0,50	19,0	80,0	14,00	11,20	17,50
1152361	2621-1736/1734	20,0	2,50	37,0	112,0	14,00	11,20	17,50
1178473	2621-1728/1726	20,0	2,00	37,0	112,0	14,00	11,20	18,00
1178470	2621-1720/1718	20,0	1,50	37,0	112,0	14,00	11,20	18,50
1178468	2621-1712/1710	20,0	1,00	29,0	102,0	14,00	11,20	19,00
1152387	2621-1783/1781	22,0	2,50	38,0	118,0	16,00	12,50	19,50
1337610	2621-1776/1774	22,0	2,00	38,0	118,0	16,00	12,50	20,00
1178483	2621-1822/1820	24,0	3,00	45,0	130,0	18,00	14,00	21,00
1337630	2621-1816/1814	24,0	2,00	35,0	120,0	18,00	14,00	22,00
1178482	2621-1808/1806	24,0	1,50	35,0	120,0	18,00	14,00	22,50
1178738	2621-1892/1890	27,0	3,00	45,0	135,0	20,00	16,00	24,00
1178490	2621-1886/1884	27,0	2,00	37,0	127,0	20,00	16,00	25,00
1234872	2621-1878/1876	27,0	1,50	37,0	127,0	20,00	16,00	25,50
1178501	2621-1960/1958	30,0	3,50	48,0	138,0	20,00	16,00	26,50
1178499	2621-1954/1952	30,0	3,00	48,0	138,0	20,00	16,00	27,00
1178497	2621-1948/1946	30,0	2,00	37,0	127,0	20,00	16,00	28,00
1479582	2621-1940/1938	30,0	1,50	37,0	127,0	20,00	16,00	28,50
1178494	2621-1932/1930	30,0	1,00	33,0	120,0	20,00	16,00	29,00
1276348	2621-2008/2006	33,0	2,00	37,0	137,0	22,40	18,00	31,00
1178741	2621-2064/2062	36,0	4,00	57,0	162,0	25,00	20,00	32,00
1178742	2621-2108/2116	39,0	4,00	60,0	170,0	28,00	22,40	35,00
1267118	2621-2088/2086	39,0	1,50	39,0	149,0	28,00	22,40	37,50
1518119	2621-2080/2078	39,0	1,00	37,0	144,0	28,00	22,40	38,00
1178744	2621-2172/2170	42,0	4,50	60,0	170,0	28,00	22,40	37,50

Метчики машинные и ручные, комплект из 2-х штук, левые, M

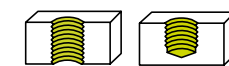

ГОСТ 3266-81



P6M5

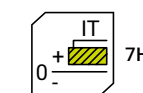

IT 7H

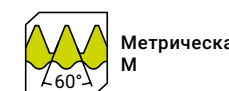

Метрическая M



Машинно-ручные

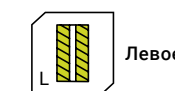

Левое

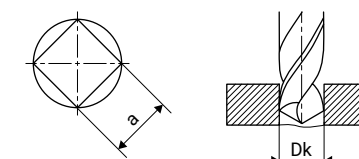
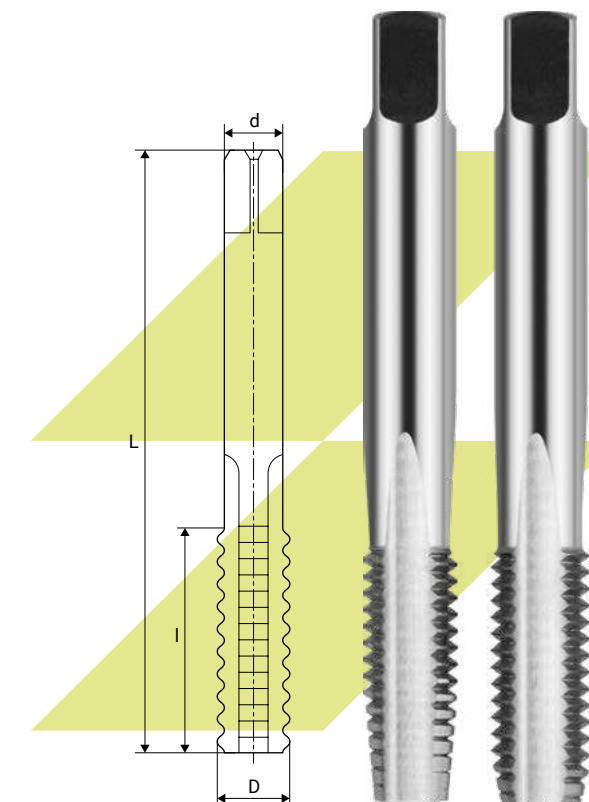

Артикул	Обозначение по ГОСТ	D, мм	P, мм	l, мм	L, мм	d, мм	a, мм	Dk, мм
1253604	2621-2534/2536	8,0	1,25	22,0	72,0	6,30	5,00	6,80
1253605	2621-2542/2544	8,0	1,00	22,0	72,0	6,30	5,00	7,00
1253813	2621-2598/2600	10,0	1,50	24,0	80,0	8,00	6,30	8,50
1253606	2621-2614/2616	10,0	1,00	24,0	80,0	8,00	6,30	9,00
1253613	2621-1568/1566	14,0	2,00	30,0	95,0	11,20	9,00	12,00
1253614	2621-1624/1622	16,0	2,00	32,0	102,0	12,50	10,00	14,00
1253615	2621-1608/1606	16,0	1,00	29,0	90,0	12,50	10,00	15,00
1253617	2621-1664/1662	18,0	1,00	37,0	95,0	14,00	11,20	17,00
1253620	2621-1736/1734	20,0	2,50	37,0	112,0	14,00	11,20	17,50
1253623	2621-1870/1868	27,0	1,00	33,0	120,0	20,00	16,00	26,00
1253624	2621-1960/1958	30,0	3,50	48,0	138,0	20,00	16,00	26,50
1253626	2621-1932/1930	30,0	1,00	33,0	120,0	20,00	16,00	29,00

Метчики машинные и ручные, комплект из 3-х штук, М

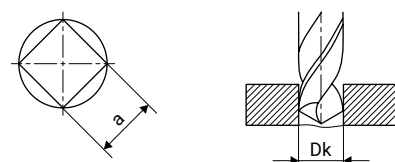
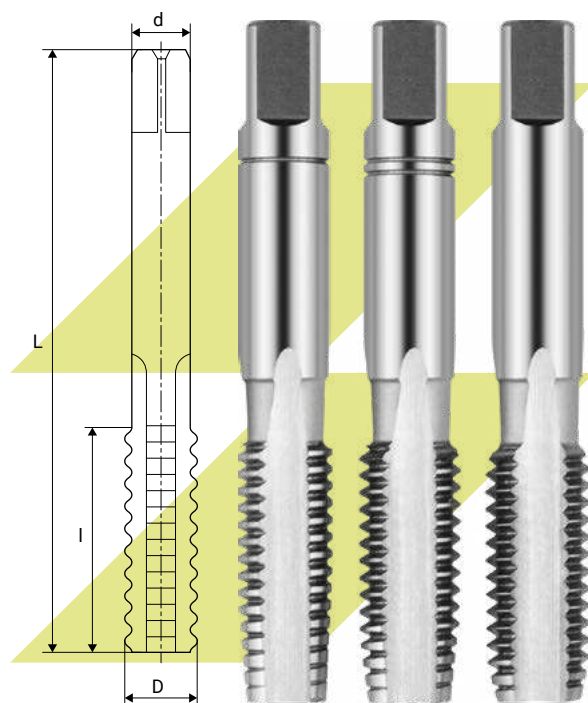
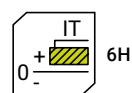
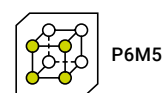
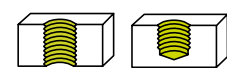

Артикул		D, мм	P, мм	I, мм	L, мм	d, мм	a, мм	Dk, мм
1220909	●	1,0	0,25	8,0	33,0	2,24	1,8	0,75
1220910	●	1,1	0,25	8,0	33,0	2,24	1,8	0,85
1220911	●	1,2	0,25	8,0	33,0	2,24	1,8	0,95
1220912	●	1,4	0,30	8,0	33,0	2,24	1,8	1,10
1220913	●	1,6	0,35	8,0	36,0	2,24	1,8	1,25
1220914	●	1,8	0,35	8,0	33,0	2,24	1,8	1,45
1220915	●	2,0	0,40	8,0	42,0	2,24	1,8	1,60
1220916	●	2,5	0,45	11,0	42,0	2,24	1,8	2,05
1220921	●	3,0	0,50	11,0	48,0	2,24	1,8	2,50
1220922	●	3,5	0,60	18,0	48,0	2,50	2,0	2,90
1220923	●	4,0	0,70	18,0	50,0	3,00	2,5	3,30
1220924	●	6,0	1,00	22,0	65,0	6,00	5,0	5,00

Артикул		D, мм	P, мм	I, мм	L, мм	d, мм	a, мм	Dk, мм
1220925	●	8,0	1,25	22,0	70,0	6,00	5,0	6,80
1417893	●	10,0	1,25	25,0	78,0	8,00	6,3	8,80
1220926	●	12,0	1,75	30,0	90,0	9,00	7,1	10,20
1152189	●	14,0	1,00	26,0	86,0	11,00	9,0	13,00
1152253	●	16,0	1,50	32,0	100,0	12,00	10,0	14,50
1152341	●	20,0	1,50	30,0	105,0	16,00	12,5	18,50
1152433	●	27,0	1,50	42,0	125,0	22,00	18,0	25,50
1152674	●	52,0	5,00	78,0	200,0	35,00	28,0	47,00

Нарезание и накатывание резьбы

Нарезание и накатывание резьбы

Метчики машинные для глухих отверстий с шахматным расположением зубьев, М

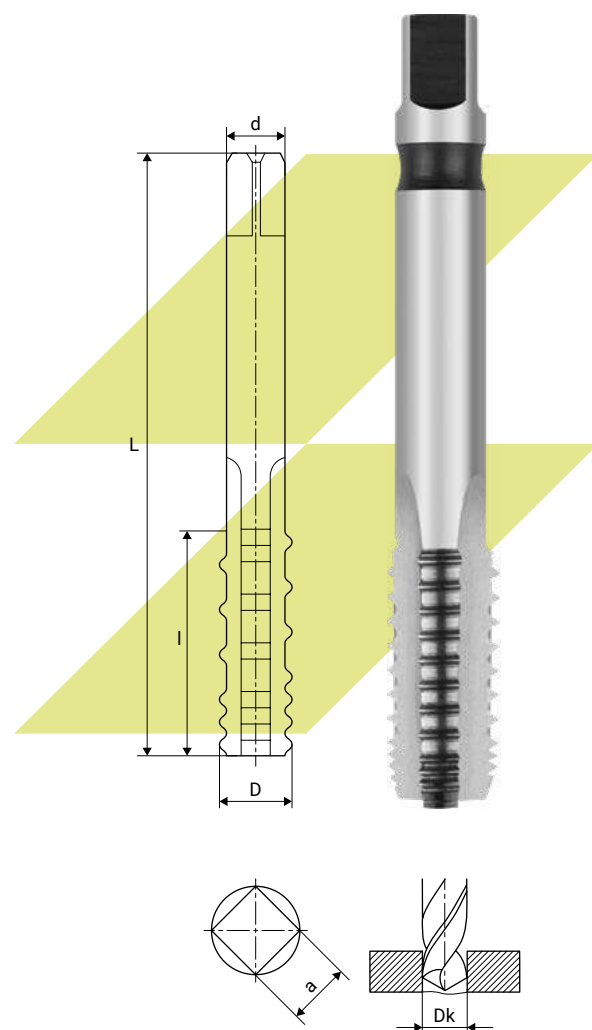
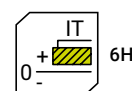
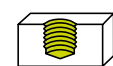

Артикул	Обозначение по ГОСТ	D, мм	P, мм	l, мм	L, мм	d, мм	a, мм	Dk, мм
1583238	2629-0235	3,0	0,50	11,0	48,0	4,0	3,15	2,60
1151949	2629-0285	6,0	1,00	19,0	66,0	6,3	5,00	5,10
1583242	2629-0327	8,0	1,00	19,0	69,0	6,3	5,00	7,10
1379392	2629-0321	8,0	1,25	22,0	72,0	6,3	5,00	6,90
1152109	2629-0399	11,0	1,50	24,0	80,0	8,0	6,30	9,70
1152130	2629-0435	12,0	1,25	24,0	84,0	9,0	7,10	10,90
1583246	2629-0423	12,0	1,75	29,0	89,0	9,0	7,10	10,40
1152223	2629-0459	14,0	2,00	30,0	95,0	11,2	9,00	12,20
1152320	2629-0609	20,0	0,75	20,0	100,0	16,0	12,50	19,25
1252646	2629-0669	24,0	1,50	35,0	120,0	18,0	14,00	22,50
1337869	2629-0723	27,0	1,50	37,0	127,0	22,4	18,00	25,50
1337870	2629-0713	27,0	3,00	45,0	135,0	22,4	18,00	24,00

Артикул	Обозначение по ГОСТ	D, мм	P, мм	l, мм	L, мм	d, мм	a, мм	Dk, мм
1253873	2629-0777	30,0	1,50	37,0	127,0	22,4	18,00	28,50
1253251	2629-0771	30,0	2,00	37,0	127,0	22,4	18,00	28,00
1258278	2629-0867	36,0	1,50	39,0	144,0	28,0	22,40	34,50

Метчики машинные с шахматным расположением зубьев, комплект из 2-х штук, М

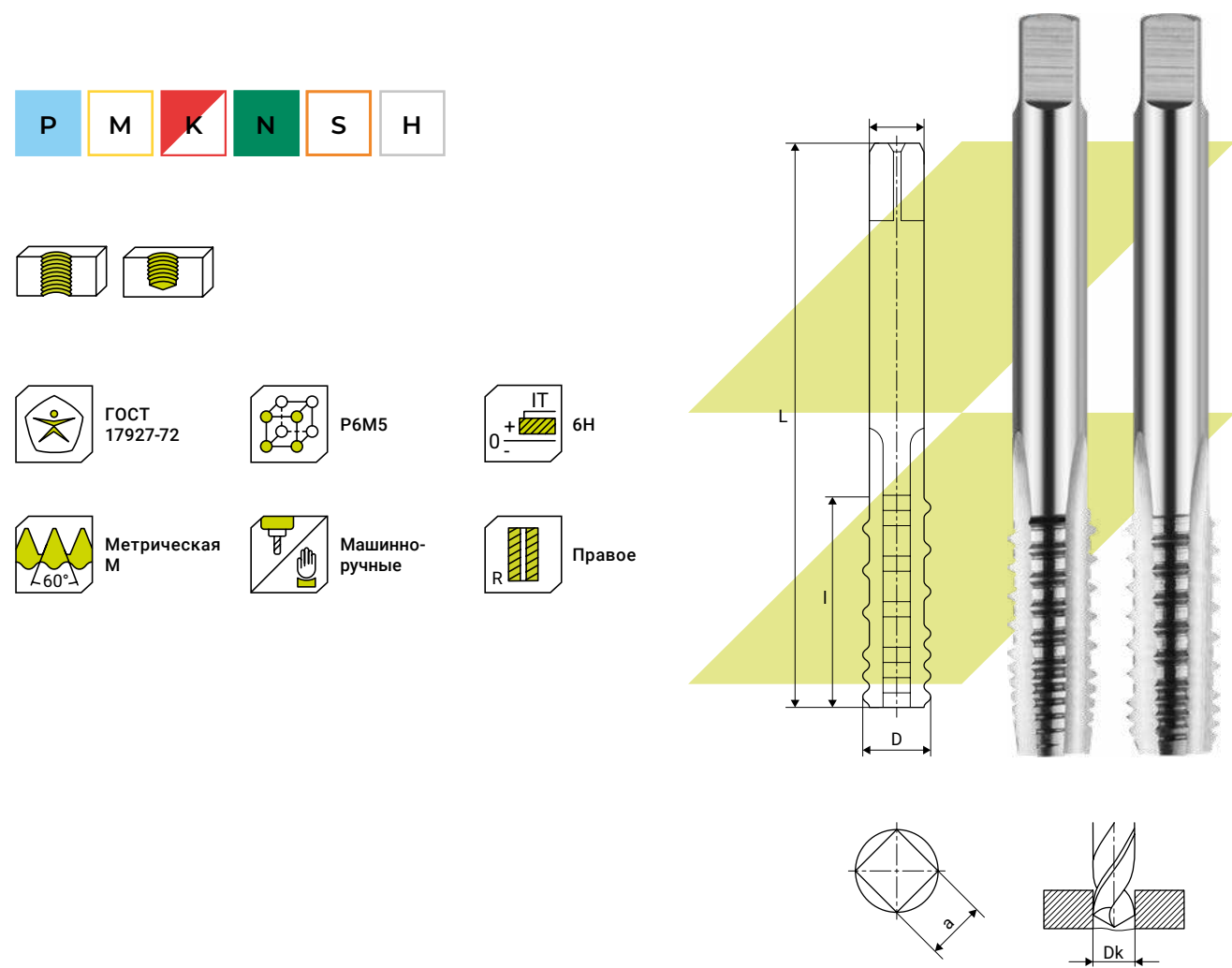

Артикул	Обозначение по ГОСТ	D, мм	P, мм	I, мм	L, мм	d, мм	a, мм	Dk, мм
1289454	2629-0225/0223	2,0	0,40	8,0	41,0	3,15	2,5	1,65
1276626	2629-0289/0287	6,0	1,00	19,0	66,0	6,30	5,0	5,10
1276625	2629-0325/0323	8,0	1,25	22,0	72,0	6,30	5,0	6,90
1276564	2629-0373/0371	10,0	1,50	24,0	80,0	8,00	6,3	8,70
1276565	2629-0427/0425	12,0	1,75	29,0	89,0	9,00	7,1	10,40
1276566	2629-0589/0587	20,0	2,50	37,0	112,0	16,00	12,5	17,50

Метчики машинные с шахматным расположением зубьев, комплект из 2-х штук, М

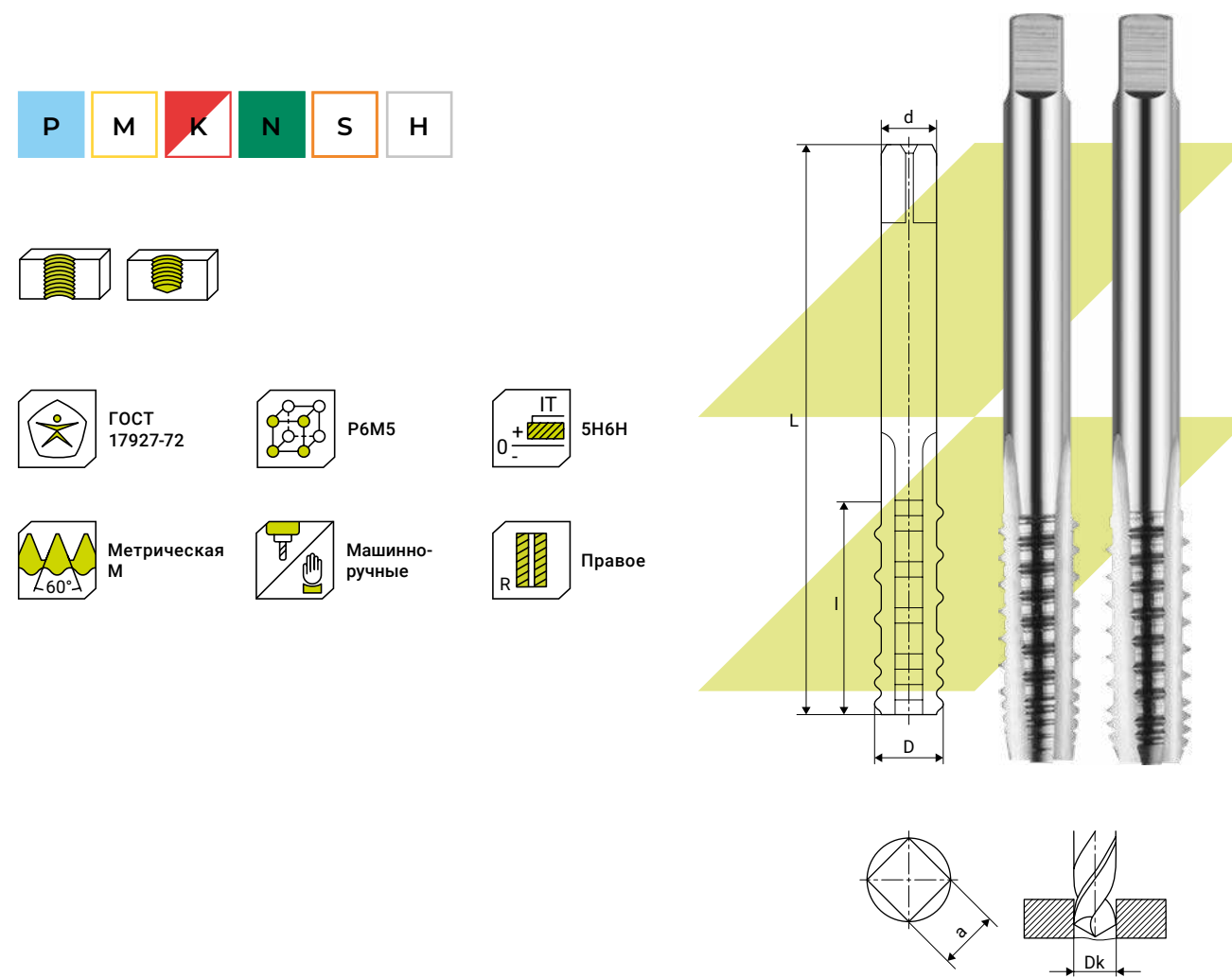

Артикул	Обозначение по ГОСТ	D, мм	P, мм	I, мм	L, мм	d, мм	a, мм	Dk, мм
1256897	2629-0225/0223	2,0	0,40	8,0	41,0	3,15	2,50	1,65
1256898	2629-0233/0231	2,5	0,45	9,5	44,5	3,15	2,50	2,10
1234638	2629-0237/0235	3,0	0,50	11,0	48,0	4,00	3,15	2,60
1234639	2629-0247/0245	4,0	0,70	13,0	53,0	5,00	4,00	3,40
1234640	2629-0271/0269	5,0	0,80	16,0	58,0	6,30	5,00	4,30
1234641	2629-0289/0287	6,0	1,00	19,0	66,0	6,30	5,00	5,10
1234642	2629-0325/0323	8,0	1,25	22,0	72,0	6,30	5,00	6,90

Метчики машинные и ручные для сквозных отверстий бесстружечные, М

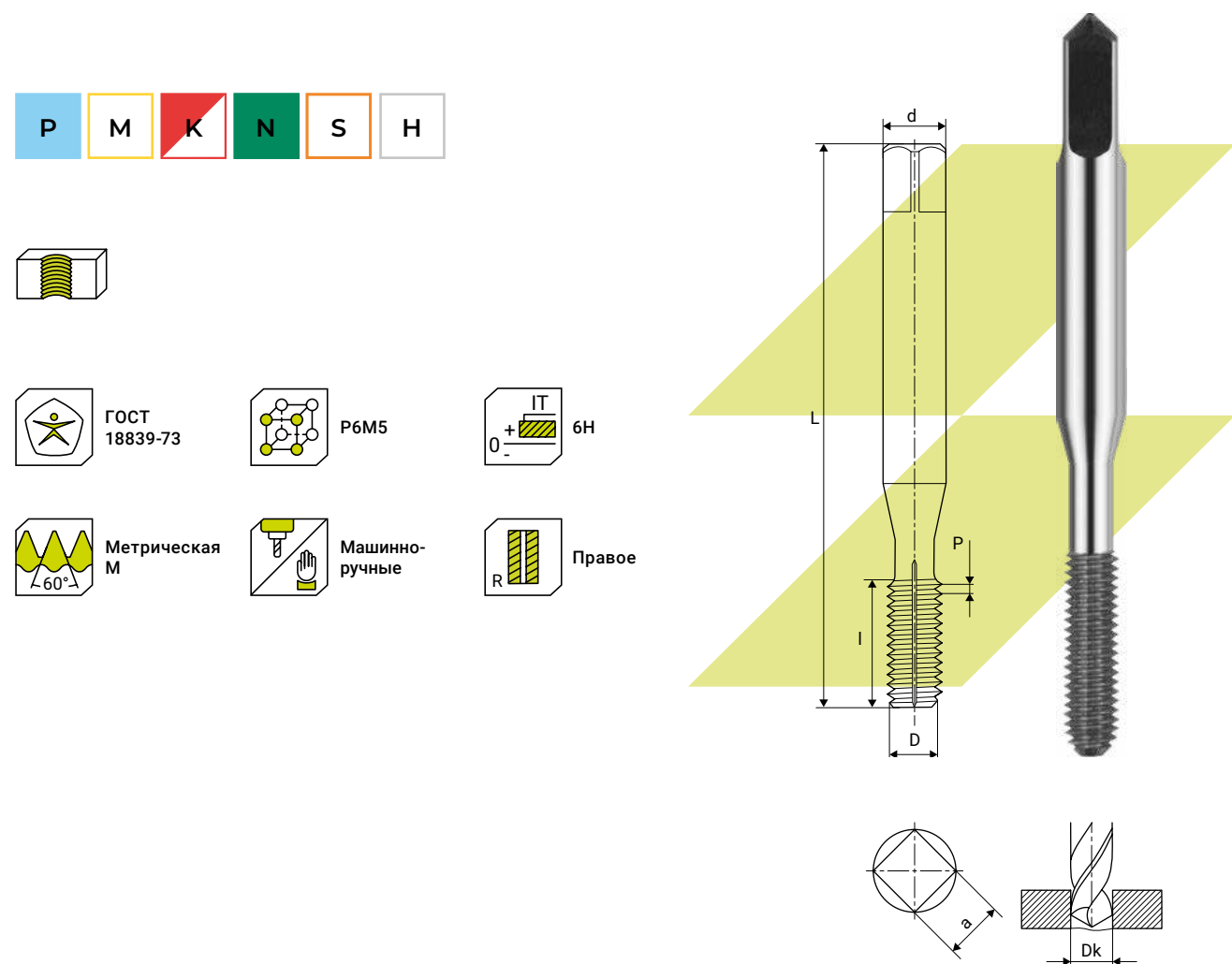

Артикул	Обозначение по ГОСТ	D, мм	P, мм	I, мм	L, мм	d, мм	a, мм	Dk, мм
1271919	1419-0021	1,2	0,25	6,0	36,0	2,24	1,80	1,10
1271921	1419-0031	1,4	0,30	7,0	40,0	2,24	1,80	1,28
1271923	1419-0041	1,6	0,35	8,0	40,0	2,24	1,80	1,47
1271925	1419-0051	1,8	0,35	8,0	40,0	2,24	1,80	1,67
1271927	1419-0061	2,0	0,40	8,0	40,0	2,50	2,00	1,85
1271929	1419-0081	2,5	0,45	10,0	45,0	2,80	2,24	2,30
1271931	1419-0091	3,0	0,50	12,0	48,0	3,15	2,50	2,80
1271933	1419-0111	4,0	0,70	12,0	52,0	4,00	3,15	3,70
1271935	1419-0131	5,0	0,80	10,0	55,0	5,00	4,00	4,65
1271937	1419-0145	6,0	1,00	12,0	65,0	6,30	5,00	5,55

Метчики машинные и ручные для глухих отверстий бесстружечные, М

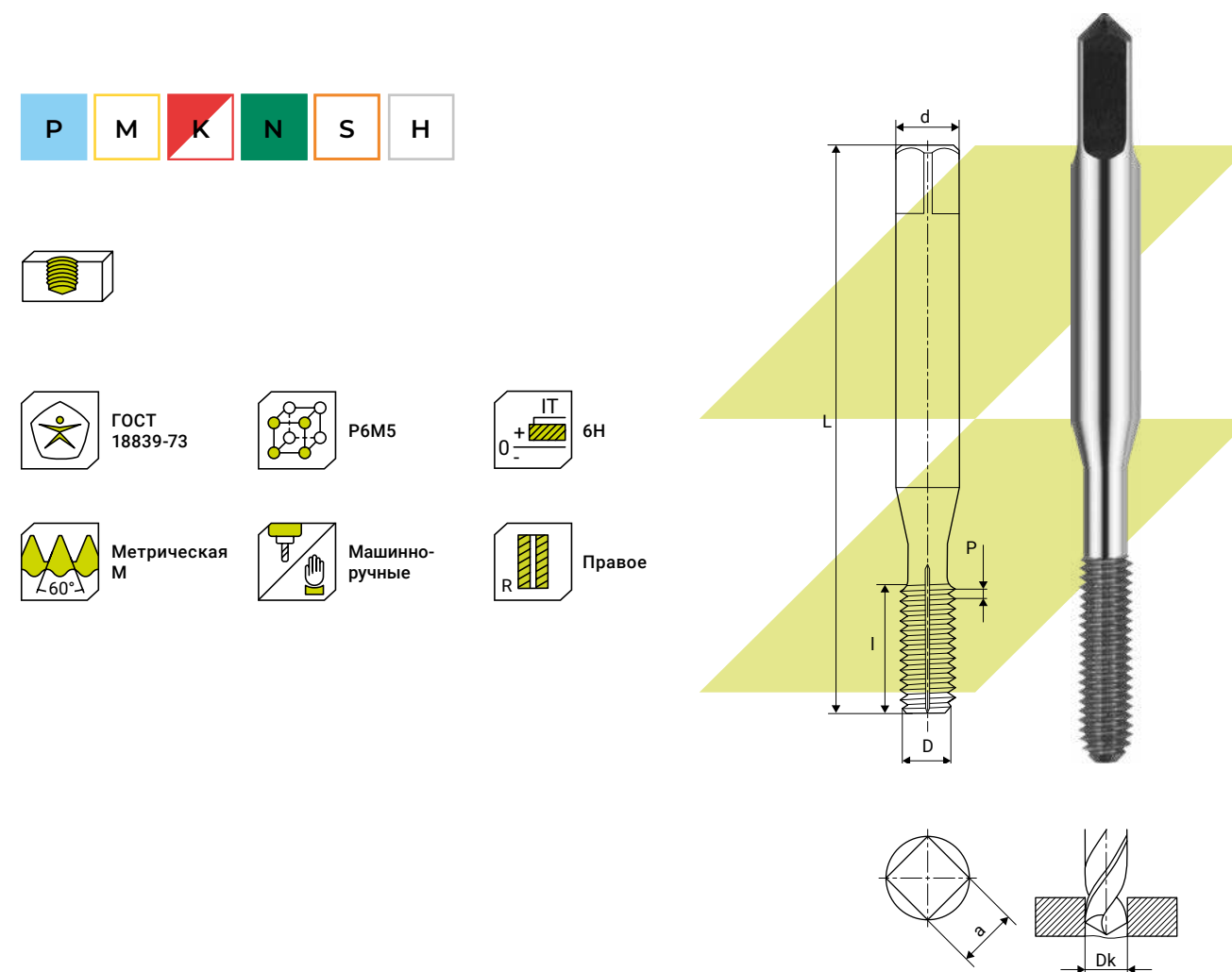

Артикул	Обозначение по ГОСТ	D, мм	P, мм	I, мм	L, мм	d, мм	a, мм	Dk, мм
1271918	1419-0023	1,2	0,25	6,0	36,0	2,24	1,80	1,10
1271920	1419-0033	1,4	0,30	7,0	40,0	2,24	1,80	1,28
1271922	1419-0043	1,6	0,35	8,0	40,0	2,24	1,80	1,47
1271924	1419-0053	1,8	0,35	8,0	40,0	2,24	1,80	1,67
1271926	1419-0063	2,0	0,40	8,0	40,0	2,50	2,00	1,85
1271928	1419-0083	2,5	0,45	10,0	45,0	2,80	2,24	2,30
1271930	1419-0093	3,0	0,50	12,0	48,0	3,15	2,50	2,80
1271932	1419-0113	4,0	0,70	12,0	52,0	4,00	3,15	3,70
1271934	1419-0133	5,0	0,80	10,0	55,0	5,00	4,00	4,65
1271936	1419-0147	6,0	1,00	12,0	65,0	6,30	5,00	5,55

Нарезание и накатывание резьбы

Нарезание и накатывание резьбы

Метчики гаечные, М

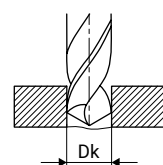
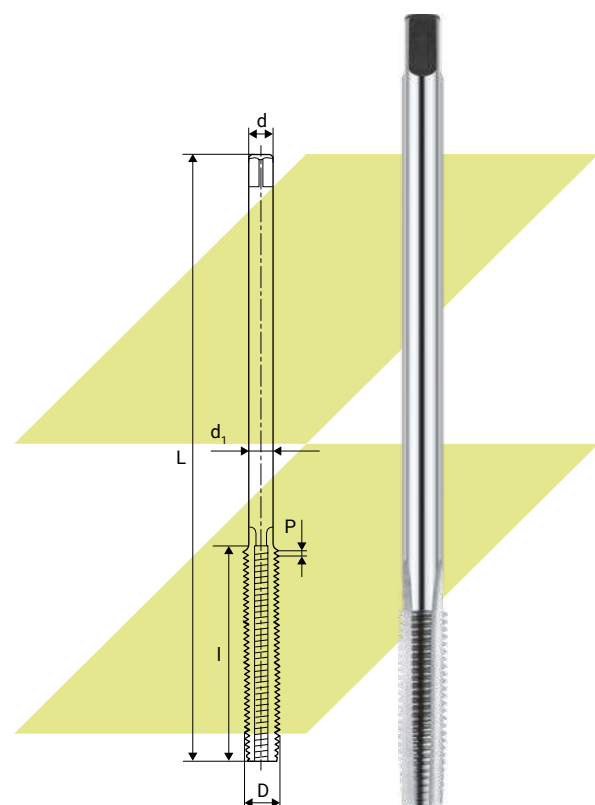
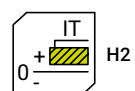
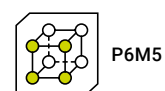

Артикул	Обозначение по ГОСТ	D, мм	P, мм	I, мм	L, мм	d, мм	d ₁ , мм	Dk, мм
1142947	—	1,4	0,30	13,0	31,0	1,00	1,00	1,10
1178710	—	1,6	0,35	10,0	68,0	1,00	1,00	1,25
1150684	—	2,0	0,40	13,0	68,0	1,50	1,50	1,60
1130840	—	2,2	0,45	14,0	99,0	1,50	1,50	1,75
1130841	—	2,3	0,45	11,0	99,0	1,50	1,50	1,85
1150685	—	2,5	0,45	13,0	68,0	2,00	2,00	2,05
102563	—	2,6	0,45	24,0	116,0	1,70	1,70	2,15
1181998	2640-0005	3,0	0,50	10,0	70,0	2,24	2,24	2,50
1343020	2640-0013	3,5	0,60	12,0	80,0	2,50	2,50	2,90
1337544	2640-0021	4,0	0,70	14,0	90,0	2,80	2,80	3,30
102570	2640-0017	4,0	0,50	10,0	90,0	2,80	3,20	3,50
1132539	2640-0029	4,5	0,50	10,0	100,0	3,15	3,70	4,00

Артикул	Обозначение по ГОСТ	D, мм	P, мм	I, мм	L, мм	d, мм	d ₁ , мм	Dk, мм
1269450	2640-0039	5,0	0,80	16,0	180,0	3,55	3,60	4,20
102576	2640-0033	5,0	0,50	10,0	110,0	3,55	4,20	4,50
1150686	2640-0053	6,0	1,00	20,0	120,0	4,50	4,50	5,00
102584	2640-0049	6,0	0,75	16,0	120,0	4,50	4,80	5,20
102582	2640-0045	6,0	0,50	10,0	120,0	4,50	5,20	5,50
1150687	2640-0081	8,0	1,25	25,0	140,0	6,30	6,30	6,80
1269452	2640-0083	8,0	1,25	25,0	220,0	6,30	6,30	6,80
1178411	2640-0117	10,0	1,50	30,0	160,0	8,00	8,00	8,50
1269453	2640-0119	10,0	1,50	30,0	250,0	8,00	8,00	8,50
1178410	2640-0109	10,0	1,00	20,0	160,0	8,00	8,40	9,00
102606	2640-0105	10,0	0,75	16,0	160,0	8,00	8,80	9,20
102620	2640-0133	11,0	1,50	30,0	160,0	8,00	8,70	9,50
1103331	2640-0129	11,0	1,00	20,0	160,0	8,00	9,40	10,00
1335488	2640-0125	11,0	0,75	16,0	160,0	8,00	9,80	10,20
102619	2640-0121	11,0	0,50	10,0	160,0	8,00	10,20	10,50
1178211	2640-0153	12,0	1,75	36,0	180,0	9,00	9,30	10,20
1269454	2640-0155	12,0	1,75	36,0	280,0	9,00	9,30	10,20
102630	2640-0149	12,0	1,50	30,0	180,0	9,00	9,70	10,50
102643	2640-0165	14,0	1,50	30,0	280,0	10,00	11,70	12,50
102639	2640-0161	14,0	1,00	20,0	180,0	10,00	12,40	13,00
102652	2640-0185	16,0	1,00	20,0	200,0	12,50	14,40	15,00
1262888	2640-0223	18,0	2,50	50,0	320,0	14,00	14,20	15,50
102673	2640-0217	18,0	2,00	40,0	200,0	14,00	14,90	16,00
102683	2640-0237	20,0	2,00	40,0	220,0	16,00	16,90	18,00
102676	2640-0229	20,0	1,00	20,0	220,0	16,00	18,40	19,00
102694	2640-0261	22,0	2,50	50,0	220,0	18,00	18,20	19,50
113307	2640-0249	22,0	1,00	20,0	220,0	18,00	20,40	21,00
1124663	—	23,0	1,50	30,0	220,0	18,00	19,70	21,50
1343007	2640-0277	24,0	3,00	60,0	250,0	18,00	19,40	21,00
102702	2640-0273	24,0	2,00	40,0	250,0	18,00	20,90	22,00
1476937	2640-0265	24,0	1,00	20,0	250,0	18,00	22,40	23,00
102708	2640-0301	27,0	2,00	40,0	250,0	20,00	23,90	25,00
1237211	2640-0297	27,0	1,50	30,0	250,0	20,00	24,70	25,50
1425247	2640-0337	30,0	3,50	70,0	280,0	22,40	24,60	26,50
102715	2640-0329	30,0	2,00	40,0	280,0	22,40	26,90	28,00
102713	2640-0325	30,0	1,50	30,0	280,0	22,40	27,70	28,50
1109324	2640-0365	33,0	1,50	30,0	280,0	25,00	30,70	31,50
1105242	2640-0373	36,0	1,50	30,0	280,0	25,00	33,70	34,50

Метчики гаечные, М

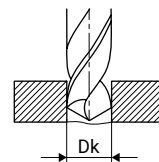
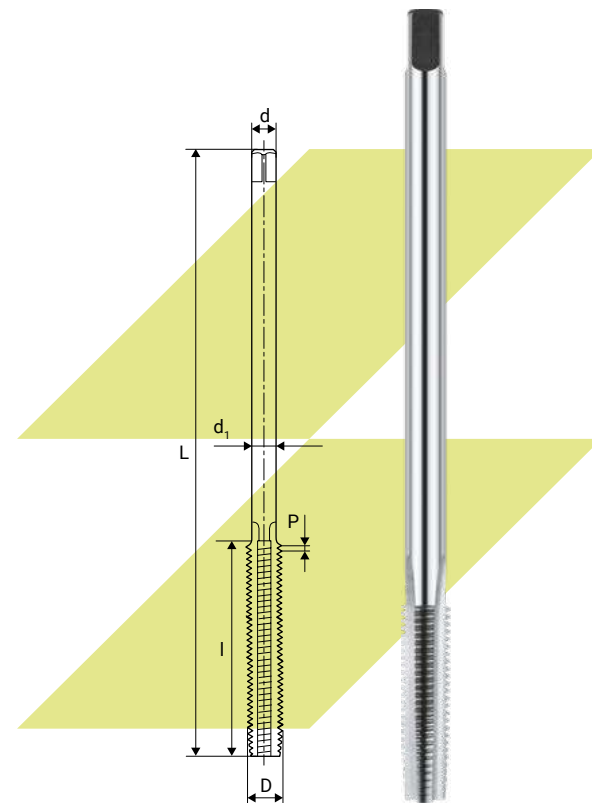
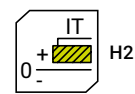

Артикул	Обозначение по ГОСТ	D, мм	P, мм	l, мм	L, мм	d, мм	d ₁ , мм	Dk, мм
1325802	—	2,5	0,45	7,0	70,0	2,24	2,24	2,05
1325803	2640-0005	3,0	0,50	10,0	70,0	2,24	2,24	2,50
102585	2640-0049	6,0	0,75	16,0	120,0	4,50	4,80	5,20
1102634	2640-0077	8,0	1,00	20,0	140,0	6,30	6,40	7,00
119418	2640-0105	10,0	0,75	16,0	160,0	8,00	8,80	9,20
102649	2640-0171	14,0	2,00	40,0	180,0	10,00	10,90	12,00
113290	2640-0209	18,0	1,00	20,0	200,0	14,00	16,40	17,00
102678	2640-0229	20,0	1,00	20,0	220,0	16,00	18,40	19,00
102696	2640-0261	22,0	2,50	50,0	220,0	18,00	18,20	19,50
102691	2640-0249	22,0	1,00	20,0	220,0	18,00	20,40	21,00
102701	2640-0273	24,0	2,00	40,0	250,0	18,00	20,90	22,00
1135016	2640-0269	24,0	1,50	30,0	250,0	18,00	21,70	22,50

Артикул	Обозначение по ГОСТ	D, мм	P, мм	l, мм	L, мм	d, мм	d ₁ , мм	Dk, мм
102698	2640-0265	24,0	1,00	20,0	250,0	18,00	22,40	23,00
1237210	2640-0297	27,0	1,50	30,0	250,0	20,00	24,70	25,50
102714	2640-0325	30,0	1,50	30,0	280,0	22,40	27,70	28,50

Метчики гаечные, левые, М

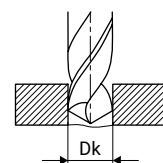
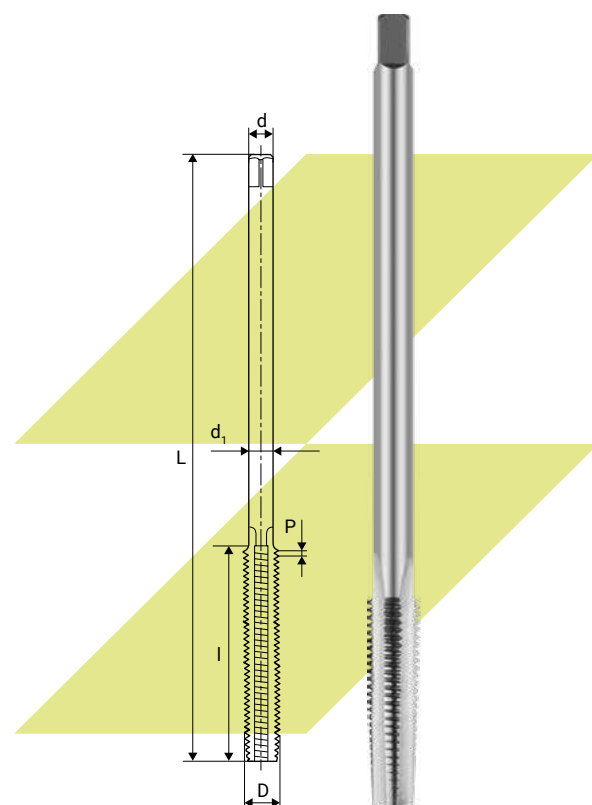
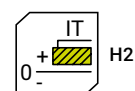

Артикул	Обозначение по ГОСТ	D, мм	P, мм	I, мм	L, мм	d, мм	d ₁ , мм	Dk, мм
1261396	2640-0082	8,0	1,25	25,0	140,0	6,30	6,30	6,75
1261400	2640-0194	16,0	2,00	40,0	200,0	12,50	12,90	14,00
1127397	2640-0497	42,0	4,50	90,0	300,0	31,50	35,10	37,50

Метчики гаечные с изогнутым хвостовиком, М

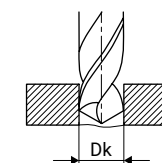
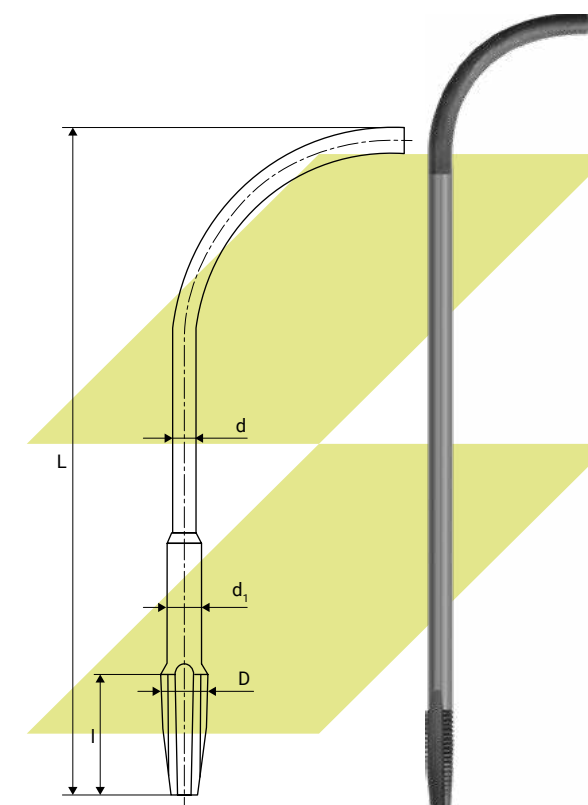
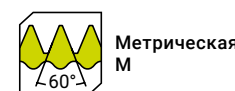
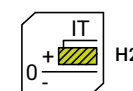

Артикул	Обозначение по ГОСТ	D, мм	P, мм	I, мм	L, мм	d, мм	d ₁ , мм	Dk, мм
102575	2642-0125	4,0	0,70	14,0	140,0	2,80	2,80	3,30
102580	2642-0131	5,0	0,80	16,0	140,0	3,60	3,60	4,20
102588	2642-0135	6,0	1,00	20,0	200,0	4,40	4,40	5,00
1242065	2642-0015	8,0	1,25	25,0	165,0	5,50	6,30	6,80
118096	2642-0145	8,0	1,00	20,0	200,0	5,80	6,40	7,00
113257	2642-0151	10,0	1,50	30,0	200,0	7,30	8,00	8,50
102613	2642-0153	10,0	1,25	25,0	200,0	7,50	8,10	8,80
113251	2642-0155	10,0	1,00	20,0	165,0	7,80	8,40	9,00
102634	2642-0031	12,0	1,75	36,0	250,0	9,00	9,30	10,20
1130282	2642-0163	12,0	1,50	30,0	300,0	9,00	9,70	10,50
102625	2642-0165	12,0	1,25	25,0	300,0	9,50	10,10	10,80
1147806	2642-0025	12,0	1,00	20,0	250,0	9,50	10,40	11,00

Нарезание и накатывание резьбы

Нарезание и накатывание резьбы

Артикул	Обозначение по ГОСТ	D, мм	P, мм	l, мм	L, мм	d, мм	d ₁ , мм	Dk, мм
1236244	2642-0039	14,0	2,00	40,0	250,0	10,50	10,90	12,00
102648	2642-0171	14,0	2,00	40,0	300,0	10,50	10,90	12,00
1585433	2642-0173	14,0	1,50	30,0	300,0	11,00	11,70	12,50
102666	2642-0045	16,0	2,00	40,0	250,0	12,50	12,90	14,00
102657	2642-0043	16,0	1,50	30,0	250,0	13,00	13,70	14,50
102654	—	16,0	1,25	22,0	300,0	13,50	14,40	14,80
113279	2642-0185	16,0	1,25	20,0	300,0	13,50	14,40	14,80
1128040	2642-0187	18,0	2,50	50,0	300,0	13,80	14,20	15,50
102695	2642-0069	22,0	2,50	50,0	340,0	17,80	18,20	19,50

Метчики ручные трубные, комплект из 2-х штук, G

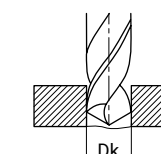
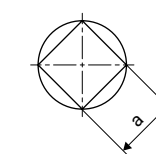
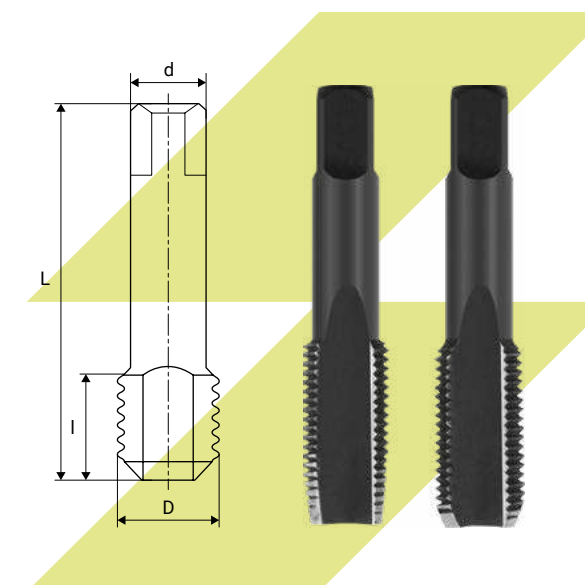
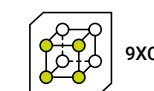
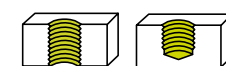

Артикул	D, дюйм	D, мм	Число ниток на 1"	l, мм	L, мм	d, мм	a, мм	Dk, мм
113669	1/8	9,728	28	18,0	80,0	8,0	6,3	8,80
113673	3/8	16,662	19	25,0	100,0	14,0	11,2	15,25
113671	1/2	20,955	14	32,0	125,0	16,0	12,5	19,00
113674	5/8	22,911	14	32,0	125,0	18,0	14,0	21,00
1378741	3/4	26,441	14	32,0	135,0	22,4	18,0	24,50
113675	7/8	30,201	14	32,0	135,0	25,0	20,0	28,25
1378742	1	33,249	11	40,0	140,0	28,0	22,4	30,75
113677	1 1/8	37,897	11	40,0	140,0	28,0	22,4	35,50
1343230	1 1/4	41,910	11	40,0	160,0	31,5	25,0	39,50
113680	1 3/8	44,323	11	40,0	160,0	31,5	25,0	41,75
1343229	1 1/2	47,805	11	40,0	160,0	35,5	28,0	45,00
103497	1 3/4	53,746	11	40,0	195,0	35,5	28,0	51,00
1343231	2	59,614	11	40,0	195,0	40,0	31,5	57,00

Метчики для дюймовой конической резьбы, К

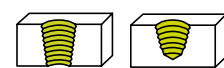

ГОСТ 6227-80

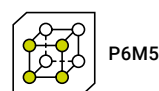

P6M5

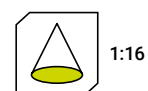

1:16



Дюймовая коническая К



Машинно-ручные



Правое

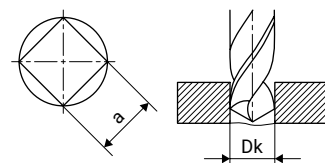
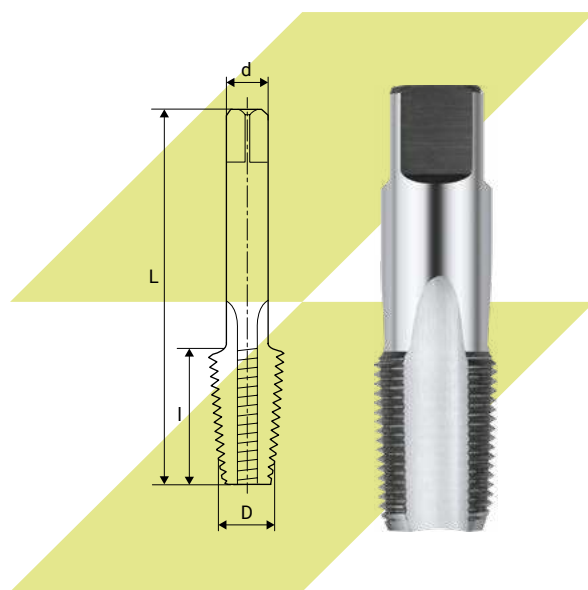

Артикул	Обозначение по ГОСТ	D, дюйм	Число ниток на 1"	I, мм	I ₁ , мм	L, мм	d, мм	a, мм	Dk, мм
1178751	2680-0001	1/16	27	16,0	15,0	50,0	6,30	5,00	6,25
1150688	2680-0003	1/8	27	18,0	16,0	55,0	8,00	6,30	8,50
1289431	2680-0005	1/4	18	24,0	16,0	65,0	11,20	9,00	11,20
1293041	2680-0007	3/8	18	26,0	16,0	75,0	14,00	11,20	14,40
1335690	2680-0008	1/2	14	30,0	21,0	85,0	18,00	14,00	18,00
1441810	2680-0009	3/4	14	32,0	21,0	95,0	22,40	18,00	23,40
1178750	2680-0010	1	11,5	40,0	26,0	110,0	28,00	22,40	29,10
1178749	2680-0011	1 1/4	11,5	42,0	27,0	120,0	31,50	25,00	37,80
1178748	2680-0012	1 1/2	11,5	42,0	27,0	140,0	35,50	28,00	44,00

Метчики машинные и ручные трубные, G

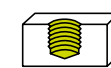

ГОСТ 3266-81

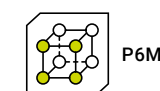

P6M5

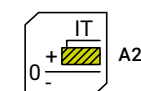

IT A2

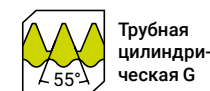

Трубная цилиндрическая G



Машинно-ручные



Правое

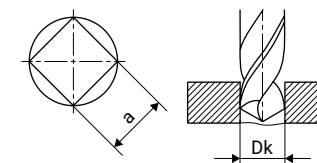
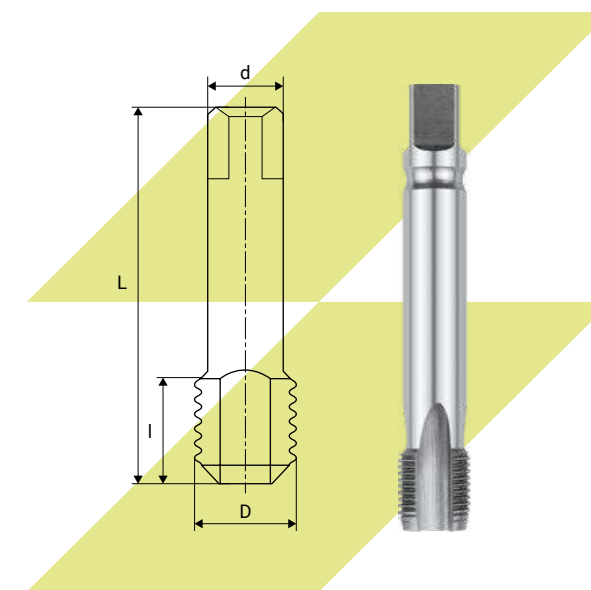

Артикул	Обозначение по ГОСТ	D, дюйм	Число ниток на 1"	I, мм	L, мм	d, мм	a, мм	Dk, мм
1326408	2625-0001	1/8	28	18,0	80,0	8,0	6,3	8,80
1326406	2625-0009	1/4	19	25,0	90,0	10,0	8,0	11,80
1234865	2625-0017	3/8	19	25,0	100,0	14,0	11,2	15,25
1326404	2625-0025	1/2	14	32,0	125,0	16,0	12,5	19,00
1326410	2625-0041	3/4	14	32,0	135,0	22,4	18,0	24,50
1418030	2625-0059	1	11	40,0	140,0	28,0	22,4	30,75
1337562	2625-0075	1 1/4	11	40,0	160,0	31,5	25,0	39,50

Метчики машинные и ручные трубные, G

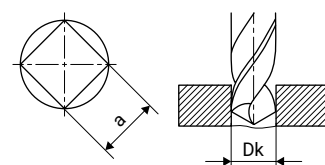
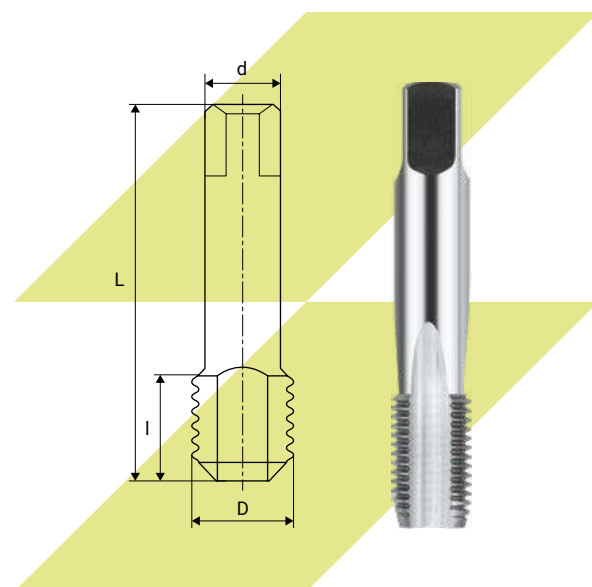
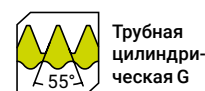
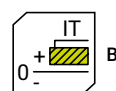
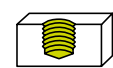

Артикул	Обозначение по ГОСТ	D, дюйм	Число ниток на 1"	l, мм	L, мм	d, мм	a, мм	Dk, мм
1416336	2625-0010	1/4	19	25,0	90,0	10,0	8,0	11,80
1416337	2625-0018	3/8	19	25,0	100,0	14,0	11,2	15,25
1416338	2625-0026	1/2	14	32,0	125,0	16,0	12,5	19,00

Метчики машинные и ручные трубные, комплект из 2-х штук, G

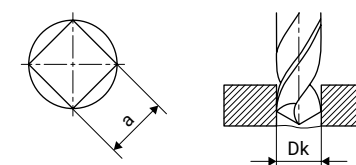
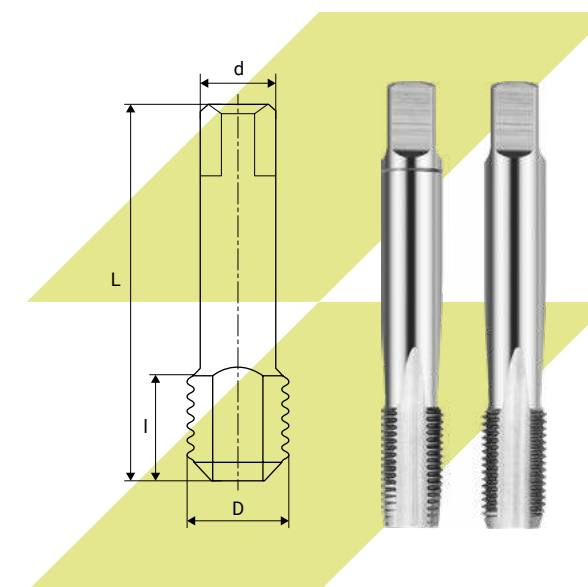
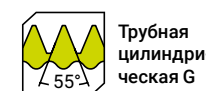
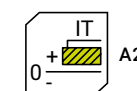
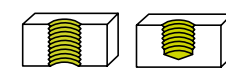

Артикул	Обозначение по ГОСТ	D, дюйм	Число ниток на 1"	l, мм	L, мм	d, мм	a, мм	Dk, мм
1326409	2625-0007/0005	1/8	28	18,0	80,0	8,0	6,3	8,80
1326407	2625-0015/0013	1/4	19	25,0	90,0	10,0	8,0	11,80
1292733	2625-0023/0021	3/8	19	25,0	100,0	14,0	11,2	15,25
1326405	2625-0031/0029	1/2	14	32,0	125,0	16,0	12,5	19,00
1292734	2625-0039/0037	5/8	14	32,0	125,0	18,0	14,0	21,00
1326411	2625-0047/0045	3/4	14	32,0	135,0	22,4	18,0	24,50
1292735	2625-0055/0053	7/8	14	32,0	135,0	25,0	20,0	28,25
1326412	2625-0063/0061	1	11	40,0	140,0	28,0	22,4	30,75
1417295	2625-0071/0069	1 1/8	11	40,0	140,0	28,0	22,4	35,50
1150755	2625-0079/0077	1 1/4	11	40,0	160,0	31,5	25,0	39,50
1583273	2625-0103/0101	1 3/8	11	40,0	160,0	31,5	25,0	41,75
1597162	2624-0095/0093	1 1/2	11	40,0	160,0	31,5	29,0	45,25
1292736	2625-0111/0109	2	11	40,0	195,0	40,0	31,5	57,00

Метчики для трубной конической резьбы, Rc

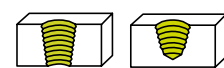

ГОСТ 6227-80



P6M5



Трубная коническая Rc

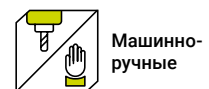

Машинно-ручные



Правое

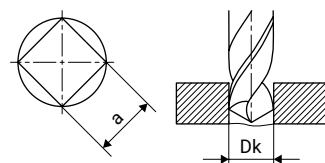
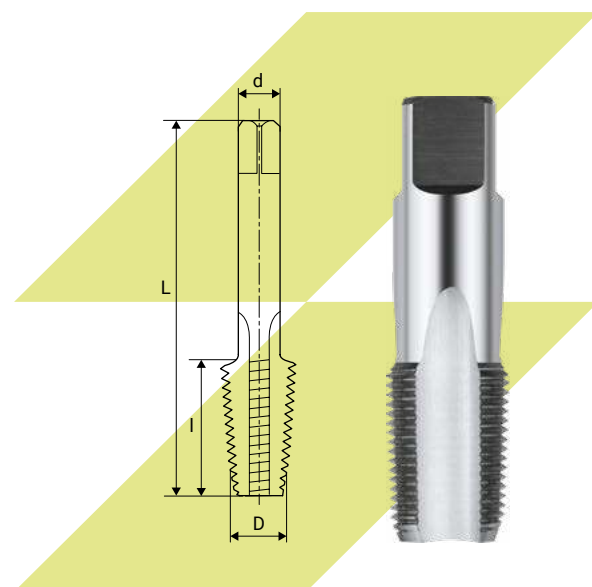

Артикул	Обозначение по ГОСТ	D, дюйм	Число ниток на 1"	l, мм	L, мм	d, мм	a, мм	Dk, мм
1220053	2680-0051	1/16	28	14,0	52,0	5,6	4,5	6,40
1614230	2680-0014	1/8	28	15,0	59,0	8,0	6,3	8,80
1417803	2680-0016	1/4	19	19,0	67,0	10,0	8,0	11,80
1614229	2680-0019	1/2	14	26,0	87,0	16,0	12,5	19,00
1614231	2680-0020	3/4	14	28,0	96,0	20,0	16,0	24,50
1614232	2680-0018	3/8	19	21,0	75,0	12,5	10,0	15,25
1858425	2680-0021	1	11	33,0	109,0	25,0	20,0	30,75
1858427	2680-0022	1 1/4	11	36,0	119,0	31,5	25,0	39,50
1858426	2680-0023	1 1/2	11	37,0	125,0	35,5	28,0	45,00
1858428	2680-0024	2	11	41,0	140,0	40,0	31,5	57,00

Метчики машинные и ручные UNC, комплект из 2-х штук

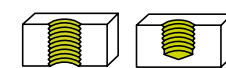

DIN 371

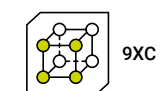

9XC



Правое



Дюймовая UNC



Машинно-ручные

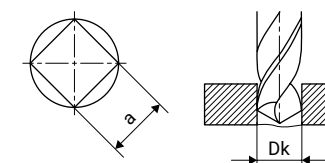
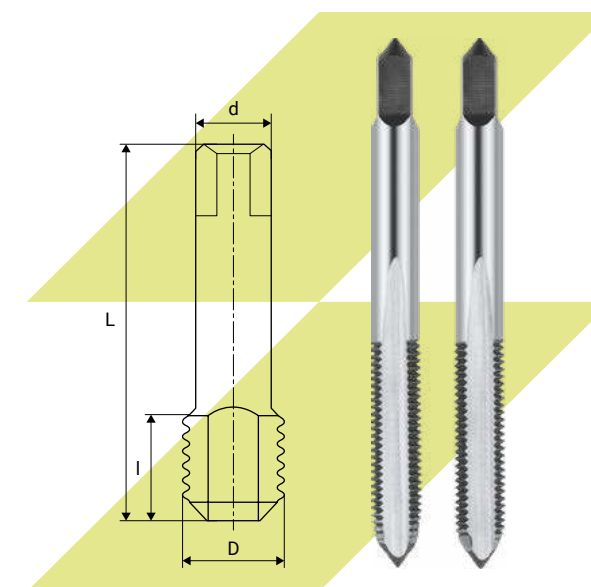

Артикул	D, дюйм	Число ниток на 1"	l, мм	L, мм	d, мм	a, мм	Dk, мм
1237432	1/4	20,0	16,0	56,0	6	4,9	5,10
1237436	5/16	18,0	18,0	63,0	6	4,9	6,60
1237434	3/8	16,0	20,0	70,0	7	5,5	8,00
1237438	7/16	14,0	22,0	70,0	8	6,2	9,40
1237431	1/2	13,0	25,0	75,0	9	7,0	10,80
1237439	9/16	12,0	30,0	80,0	11	9,0	12,20
1379547	5/8	11,0	30,0	80,0	12	9,0	13,50
1237433	3/4	10,0	33,0	95,0	16	12,0	16,50
1237437	7/8	9,0	35,0	100,0	18	14,5	19,50
1237445	1	8,0	38,0	110,0	18	14,5	22,25
1237442	1 1/8	7,0	44,0	125,0	22	18,0	25,00
1237441	1 1/4	7,0	44,0	125,0	22	18,0	28,00

Артикул		D, дюйм	Число ниток на 1"	l, мм	L, мм	d, мм	a, мм	Dk, мм
1237444	●	1 3/8	6,0	50,0	150,0	28	22,0	30,75
1237440	●	1 1/2	6,0	50,0	150,0	32	24,0	34,00
1237443	●	1 3/4	5,0	58,0	160,0	36	29,0	39,50
1237446	●	2	4,5	65,0	180,0	40	32,0	45,00

Метчики машинные и ручные UNC, комплект из 2-х штук

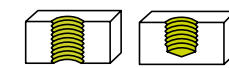

DIN 371

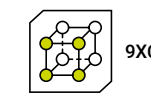

9XC



Правое



Дюймовая UNC



Машинно-ручные

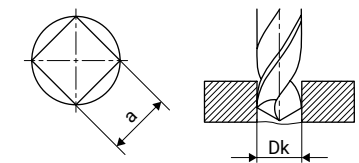
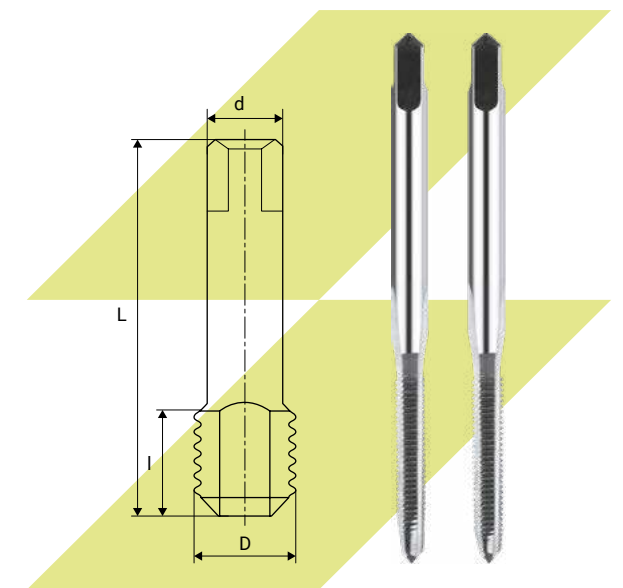

Артикул		D, дюйм	Число ниток на 1"	l, мм	L, мм	d, мм	a, мм	Dk, мм
1237422	●	№ 1	64	8,0	36,0	2,8	2,1	1,55
1237423	●	№ 2	56	9,0	36,0	2,8	2,1	1,85
1237424	●	№ 3	48	9,0	40,0	2,8	2,1	2,10
1237425	●	№ 4	40	10,0	40,0	3,5	2,7	2,35
1237426	●	№ 5	40	10,0	40,0	4,0	3,0	2,65
1237427	●	№ 6	32	11,0	45,0	4,0	3,0	2,85
1237428	●	№ 8	32	12,0	45,0	4,5	3,4	3,50
1237429	●	№10	24	14,0	50,0	6,0	4,9	3,90
1237430	●	№12	24	16,0	56,0	6,0	4,9	4,50

Метчики машинные и ручные UNF, комплект из 2-х штук

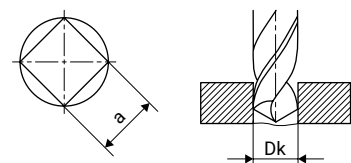
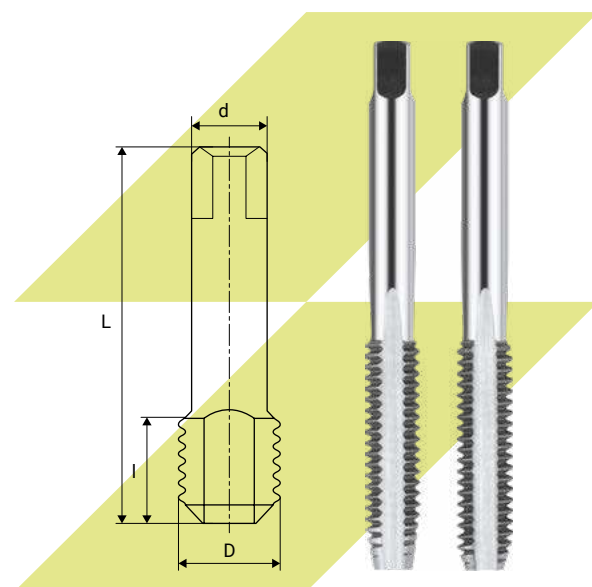
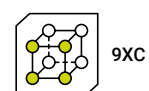
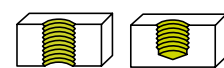

Артикул		D, дюйм	Число ниток на 1"	I, мм	L, мм	d, мм	a, мм	Dk, мм
1237458	●	1/4	28	17,0	56,0	6,0	4,9	5,50
1237462	●	5/16	24	17,0	63,0	6,0	4,9	6,90
1237460	●	3/8	24	18,0	63,0	7,0	5,5	8,50
1237464	●	7/16	20	20,0	70,0	8,0	6,2	9,90
1237457	●	1/2	20	20,0	70,0	9,0	7,0	11,50
1237465	●	9/16	18	20,0	70,0	11,0	9,0	12,90
1417884	●	5/8	18	20,0	70,0	12,0	9,0	14,50
1237459	●	3/4	16	22,0	80,0	16,0	12,0	17,50
1237463	●	7/8	14	22,0	80,0	18,0	14,5	20,40
1237470	●	1	12	22,0	90,0	18,0	14,5	23,25
1237468	●	1 1/8	12	22,0	90,0	22,0	18,0	26,50
1237467	●	1 1/4	12	22,0	90,0	22,0	18,0	29,50

Артикул		D, дюйм	Число ниток на 1"	I, мм	L, мм	d, мм	a, мм	Dk, мм
1237469	●	1 3/8	12	30,0	125,0	28,0	22,0	32,75
1237466	●	1 1/2	12	30,0	125,0	32,0	24,0	36,00

Метчики машинные и ручные UNF, комплект из 2-х штук

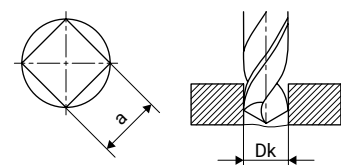
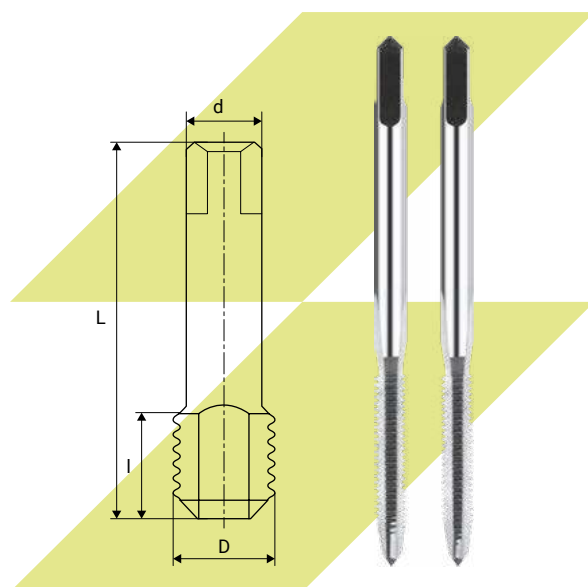
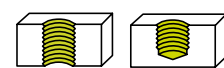

Артикул	№ дюйм	Число ниток на 1"	I, мм	L, мм	d, мм	a, мм	Dk, мм
1237447	№ 0	80	8,0	32,0	2,5	2,1	1,25
1237448	№ 1	72	8,0	36,0	2,8	2,1	1,55
1237449	№ 2	64	9,0	36,0	2,8	2,1	1,85
1237450	№ 3	56	9,0	40,0	2,8	2,1	2,15
1237451	№ 4	48	10,0	40,0	3,5	2,7	2,40
1237452	№ 5	44	10,0	40,0	4,0	3,0	2,70
1237453	№ 6	40	11,0	45,0	4,0	3,0	2,95
1237454	№ 8	36	12,0	45,0	4,5	3,4	3,50
1237455	№10	32	14,0	50,0	6,0	4,9	4,10
1237456	№12	28	16,0	56,0	6,0	4,9	4,60

Метчики трубные электротехнические, PG

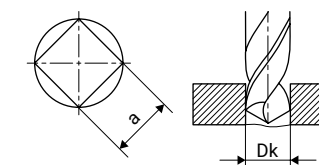
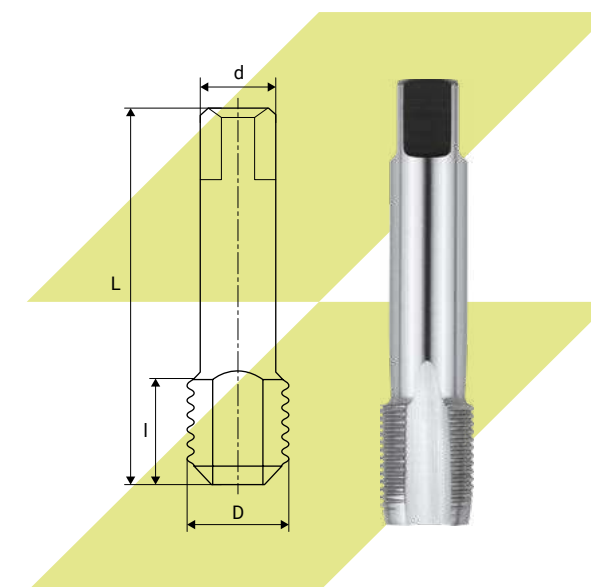
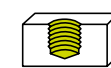

Артикул	D, мм	Число ниток на 1"	I, мм	L, мм	d, мм	a, мм	Dk, мм
1237589	7,0	20	22,0	70,0	9,0	7,0	11,50
1237590	9,0	18	22,0	70,0	12,0	9,0	14,00
1237591	11,0	18	22,0	80,0	14,0	11,0	17,25
1237592	13,5	18	22,0	80,0	16,0	12,0	19,00
1237593	16,0	18	22,0	80,0	18,0	14,5	21,25
1237594	21,0	16	22,0	90,0	22,0	18,0	27,00

Метчики машинные и ручные BSW, комплект из 2-х штук

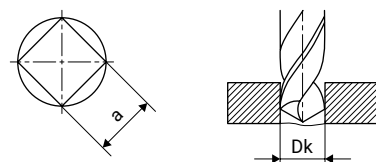
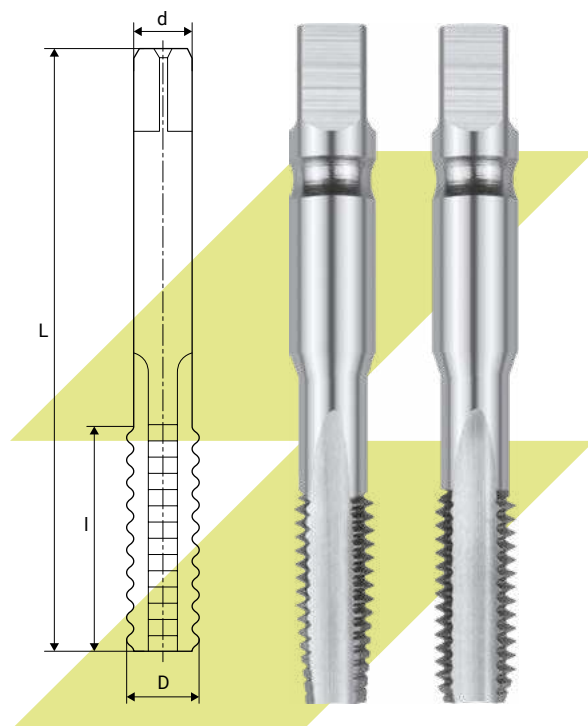
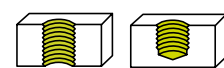

Артикул		D, дюйм	Число ниток на 1"	I, мм	L, мм	d, мм	a, мм	Dk, мм
1237407	●	3/32	48,0	9,0	40,0	2,8	2,1	1,80
1237401	●	1/8	40,0	11,0	40,0	4,0	3,0	2,50
1237410	●	5/32	32,0	13,0	45,0	4,5	3,4	3,20
1237406	●	3/16	24,0	14,0	50,0	6,0	4,9	3,60
1237400	●	1/4	20,0	16,0	56,0	6,0	4,9	5,10
1237409	●	5/16	18,0	18,0	63,0	6,0	4,9	6,50
1237405	●	3/8	16,0	20,0	70,0	7,0	5,5	7,90
1237412	●	7/16	14,0	22,0	70,0	8,0	6,2	9,20
1237399	●	1/2	12,0	25,0	75,0	9,0	7,0	10,50
1237413	●	9/16	12,0	30,0	80,0	11,0	9,0	12,00
1237408	●	5/8	11,0	30,0	80,0	12,0	9,0	13,50
1237403	●	11/16	11,0	47,0	96,0	12,0	9,0	15,00

Артикул		D, дюйм	Число ниток на 1"	I, мм	L, мм	d, мм	a, мм	Dk, мм
1237404	●	3/4	10,0	33,0	95,0	16,0	12,0	16,25
1237411	●	7/8	9,0	35,0	100,0	18,0	14,5	19,25
1237420	●	1	8,0	38,0	110,0	18,0	14,5	22,00
1237416	●	1 1/8	7,0	40,0	125,0	22,0	18,0	24,75
1237415	●	1 1/4	7,0	44,0	125,0	22,0	18,0	27,75
1237418	●	1 3/8	6,0	50,0	150,0	28,0	22,0	30,50
1237414	●	1 1/2	6,0	50,0	150,0	32,0	24,0	33,50
1237419	●	1 5/8	5,0	58,0	150,0	32,0	24,0	35,50
1237417	●	1 3/4	5,0	58,0	160,0	36,0	29,0	39,00
1237421	●	2	4,5	65,0	180,0	40,0	32,0	44,50

Нарезание и накатывание резьбы

Нарезание и накатывание резьбы

Метчики машинные и ручные BSF, комплект из 2-х штук

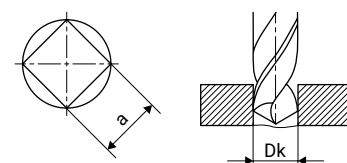
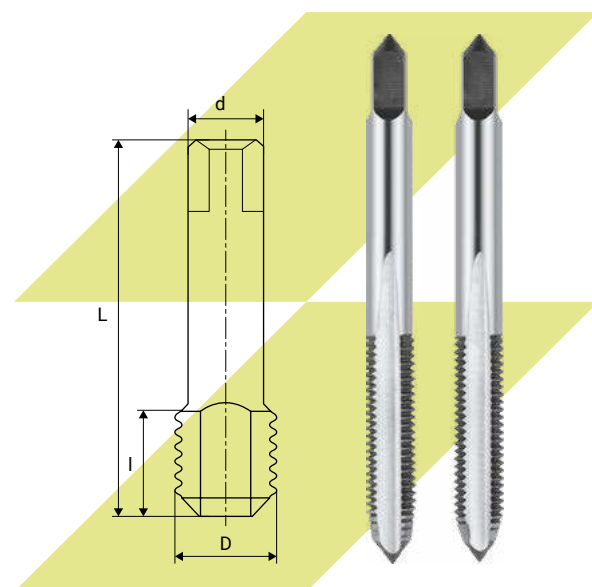
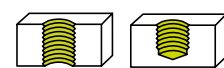

Артикул		D, дюйм	Число ниток на 1"	I, мм	L, мм	d, мм	a, мм	Dk, мм
1237385	●	3/16	32	14,0	50,0	6,0	4,9	3,60
1416339	●	7/32	28	16,0	56,0	6,0	4,9	4,50
1237381	●	1/4	26	16,0	56,0	6,0	4,9	5,10
1237387	●	5/16	22	18,0	63,0	6,0	4,9	6,50
1237384	●	3/8	20	20,0	70,0	7,0	5,5	7,90
1237389	●	7/16	18	22,0	70,0	8,0	6,2	9,20
1237380	●	1/2	16	25,0	75,0	9,0	7,0	10,50
1237390	●	9/16	16	30,0	80,0	11,0	9,0	12,00
1237386	●	5/8	14	30,0	80,0	12,0	9,0	13,50
1237382	●	11/16	14	47,0	96,0	12,0	9,0	15,00
1237383	●	3/4	12	33,0	95,0	16,0	12,0	16,25
1237388	●	7/8	11	35,0	100,0	18,0	14,5	19,25

Артикул		D, дюйм	Число ниток на 1"	I, мм	L, мм	d, мм	a, мм	Dk, мм
1237397	●	1	10	38,0	110,0	18,0	14,5	22,00
1237393	●	1 1/8	9	40,0	125,0	22,0	18,0	24,75
1237392	●	1 1/4	9	44,0	125,0	22,0	18,0	27,75
1237395	●	1 3/8	8	50,0	150,0	28,0	22,0	30,50
1237391	●	1 1/2	8	50,0	150,0	32,0	24,0	33,50
1237396	●	1 5/8	8	58,0	150,0	32,0	24,0	35,50
1237394	●	1 3/4	7	58,0	160,0	36,0	29,0	39,00
1237398	●	2	7	65,0	180,0	40,0	32,0	44,50

Метчики для трапецеидальной резьбы, комплект из 3-х штук, Tr

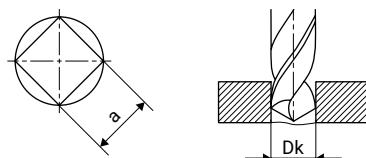
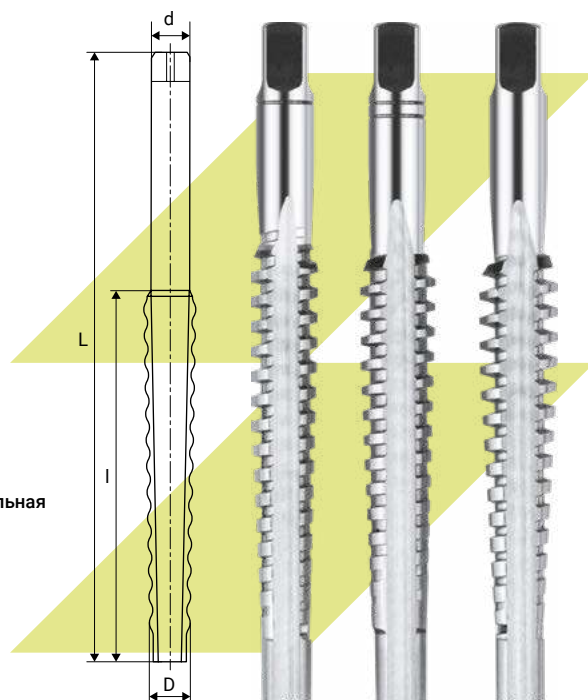
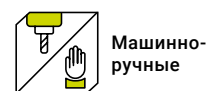
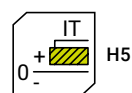
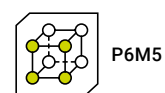
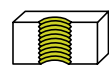

Артикул		D, мм	P, мм	I, мм	L, мм	d, мм	a, мм	Dk, мм
1240355	●	10,0	2	54,0	80,0	10,0	8,0	8,0
1240357	●	10,0	3	54,0	80,0	10,0	8,0	7,0
1152707	●	12,0	2	74,0	120,0	8,0	6,0	10,0
1152711	●	12,0	3	74,0	120,0	8,0	6,0	9,0
1343226	●	12,0	4	74,0	120,0	8,0	6,0	8,0
1417624	●	14,0	2	80,0	120,0	10,0	8,0	12,0
1152715	●	14,0	3	80,0	120,0	10,0	8,0	11,0
1152717	●	14,0	4	80,0	120,0	10,0	8,0	10,0
1343249	●	16,0	2	120,0	170,0	11,0	9,0	14,0
1417626	●	16,0	3	120,0	170,0	11,0	9,0	13,0
1152720	●	16,0	4	120,0	170,0	11,0	9,0	12,0
1343227	●	18,0	2	120,0	170,0	12,0	10,0	16,0

Артикул		D, мм	P, мм	I, мм	L, мм	d, мм	a, мм	Dk, мм
1417628	●	18,0	3	120,0	170,0	12,0	10,0	15,0
1152722	●	18,0	4	120,0	170,0	12,0	10,0	14,0
1417630	●	20,0	2	120,0	170,0	14,0	11,0	18,0
1417632	●	20,0	3	120,0	170,0	14,0	11,0	17,0
1152728	●	20,0	4	120,0	170,0	14,0	11,0	16,0
1152731	●	22,0	5	180,0	250,0	17,0	13,0	17,0
1417896	●	24,0	3	180,0	250,0	18,0	14,0	21,0
1152735	●	24,0	5	180,0	250,0	18,0	14,0	19,0
1152737	●	26,0	5	180,0	250,0	20,0	16,0	21,0
1152739	●	28,0	5	180,0	250,0	22,0	18,0	23,0
1253277	●	30,0	6	200,0	300,0	23,0	18,0	24,0

Метчики для трапецеидальной резьбы, комплект из 3-х штук, левые, Tr

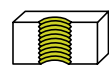

ГОСТ 19831-74/
DIN 103



P6M5

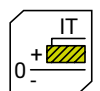

H5



Левое



Машинно-
ручные



Трапецеидальная
Tr

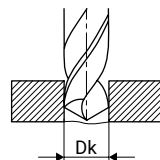
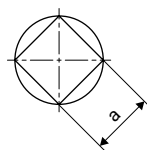

Артикул		D, мм	P, мм	I, мм	L, мм	d, мм	a, мм	Dk, мм
1240356	●	10,0	2	54,0	80,0	7,0	5,5	8,0
1240358	●	10,0	3	54,0	80,0	7,0	5,5	7,0
1152708	●	12,0	2	76,0	116,0	8,0	6,0	10,0
1152712	●	12,0	3	80,0	116,0	8,0	6,0	9,0
1417623	●	12,0	4	84,0	116,0	8,0	6,0	8,0
1417625	●	14,0	2	80,0	116,0	10,0	8,0	12,0
1152716	●	14,0	3	84,0	116,0	10,0	8,0	11,0
1152718	●	14,0	4	146,0	190,0	10,0	8,0	10,0
1343250	●	16,0	2	120,0	170,0	12,0	9,0	14,0
1417627	●	16,0	3	124,0	170,0	11,0	9,0	13,0
1152721	●	16,0	4	124,0	170,0	11,0	9,0	12,0
1343228	●	18,0	2	120,0	170,0	12,0	10,0	16,0

Артикул		D, мм	P, мм	I, мм	L, мм	d, мм	a, мм	Dk, мм
1417629	●	18,0	3	120,0	170,0	12,0	10,0	15,0
1152723	●	18,0	4	124,0	170,0	12,0	10,0	14,0
1417631	●	20,0	2	120,0	170,0	14,0	11,0	18,0
1417633	●	20,0	3	120,0	170,0	14,0	11,0	17,0
1152729	●	20,0	4	112,0	170,0	14,0	11,0	16,0
1152732	●	22,0	5	180,0	240,0	17,0	13,0	17,0
1152736	●	24,0	5	186,0	254,0	17,0	14,0	19,0
1152738	●	26,0	5	178,0	250,0	20,0	18,0	21,0
1152740	●	28,0	5	182,0	250,0	22,0	18,0	23,0

Метчики машинные и ручные для резьбы вентилях камер и шин, V

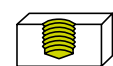

DIN 371



P6M5



Правое



Метрическая V



Машинно-ручные

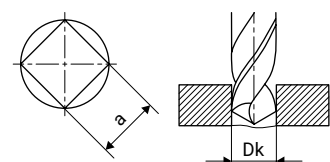
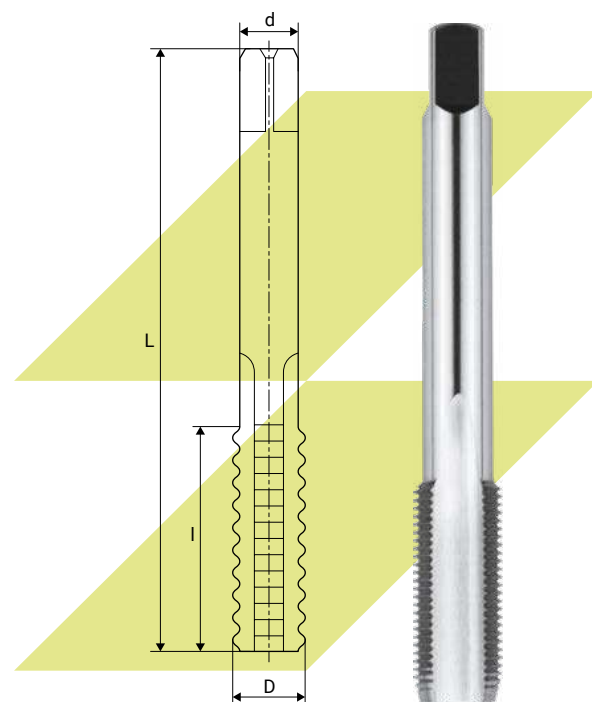

Артикул		D, мм	P, мм	I, мм	L, мм	d, мм	a, мм	Dk, мм
1236696	●	5,2	0,705	20,0	60,0	5,0	4,0	4,5
1236697	●	5,2	1,058	16,0	68,0	6,0	5,0	4,1
1236698	●	6,0	0,800	18,0	66,0	6,0	5,0	5,2
1236699	●	7,7	0,794	22,0	70,0	6,0	5,0	6,9
1236700	●	7,9	1,058	22,0	70,0	6,0	5,0	6,8
1236701	●	9,4	0,794	26,0	76,0	8,0	6,0	8,6
1236702	●	9,6	1,000	26,0	76,0	8,0	6,0	8,6
1236703	●	10,3	0,907	26,0	76,0	8,0	6,0	9,4
1236704	●	11,1	1,270	24,0	80,0	8,0	6,0	9,8
1236705	●	12,2	0,977	24,0	80,0	9,0	7,0	11,2
1236706	●	12,6	1,270	32,0	88,0	9,0	7,0	11,3
1236707	●	12,7	0,794	32,0	88,0	9,0	7,0	11,9

Артикул		D, мм	P, мм	I, мм	L, мм	d, мм	a, мм	Dk, мм
1236708	●	15,0	1,000	26,0	96,0	11,0	9,0	14,0
1236709	●	15,8	0,941	20,0	96,0	12,0	10,0	14,9
1236710	●	17,0	1,000	24,0	98,0	14,0	11,0	16,0
1236711	●	17,5	1,058	24,0	98,0	14,0	11,0	16,4
1236712	●	17,5	1,588	24,0	98,0	14,0	11,0	15,9
1236713	●	19,0	1,588	30,0	102,0	14,0	11,0	17,4
1236714	●	20,5	1,000	30,0	102,0	14,0	11,0	19,5

Метчики машинные и ручные твердосплавные, М

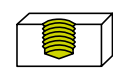

ТУ2-035-446-83



ВК8



6H



Метрическая М



Машинно-ручные



Правое

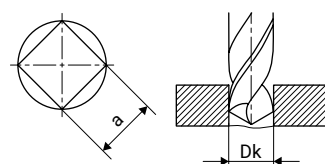
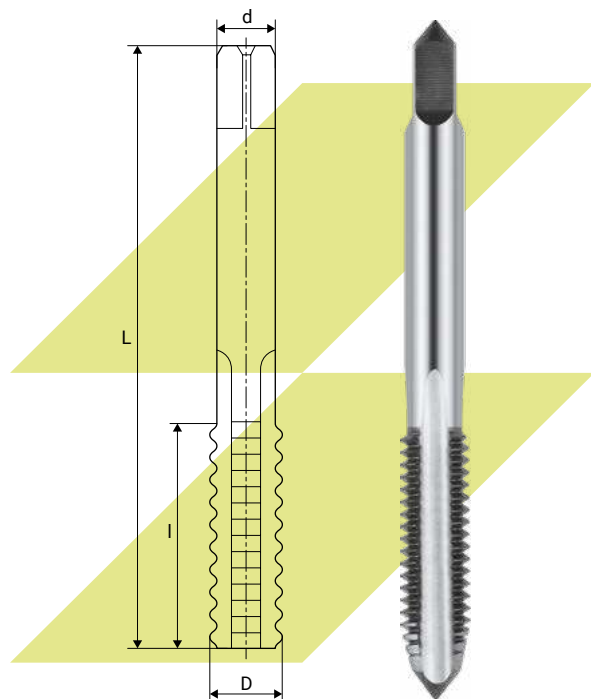

Артикул		D, мм	P, мм	I, мм	L, мм	d, мм	a, мм	Dk, мм
1252513	●	4,0	0,70	17,0	52,0	4,0	3,15	3,40
1252515	●	5,0	0,80	20,0	55,0	4,0	3,15	4,30
1252517	●	6,0	1,00	23,0	62,0	6,0	5,00	5,10
1289584	●	8,0	1,25	23,0	73,0	6,0	5,00	6,90
1479572	●	10,0	1,50	25,0	82,0	8,0	6,30	8,60
1152163	●	12,0	1,75	30,0	92,0	9,0	7,10	10,40

Метчики машинные и ручные твердосплавные, комплект из 2-х штук, М

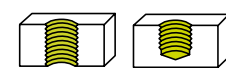

ТУ2-035-446-83



ВК8



6H

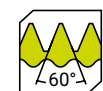

Метрическая М



Машинно-ручные



Правое

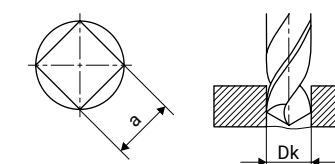
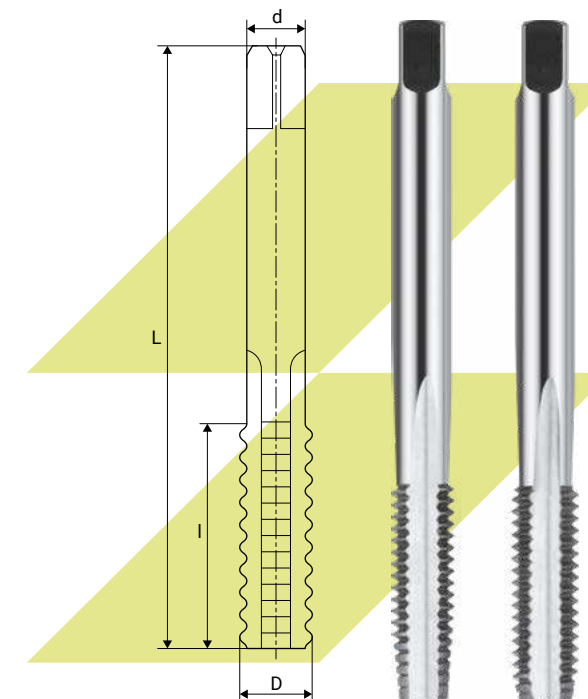

Артикул		D, мм	P, мм	I, мм	L, мм	d, мм	a, мм	Dk, мм
1252512	●	3,0	0,50	15,0	48,0	3,0	2,50	2,60
1252514	●	4,0	0,70	17,0	52,0	4,0	3,15	3,40
1252516	●	5,0	0,80	20,0	55,0	4,0	3,15	4,30
1252518	●	6,0	1,00	23,0	62,0	6,0	5,00	5,10
1252519	●	8,0	1,25	23,0	73,0	6,0	5,00	6,90
1252520	●	10,0	1,50	25,0	82,0	8,0	6,30	8,60
1252521	●	12,0	1,75	30,0	92,0	9,0	7,10	10,40

Нарезание и накатывание резьбы

Нарезание и накатывание резьбы

Плашки круглые для метрической резьбы, М

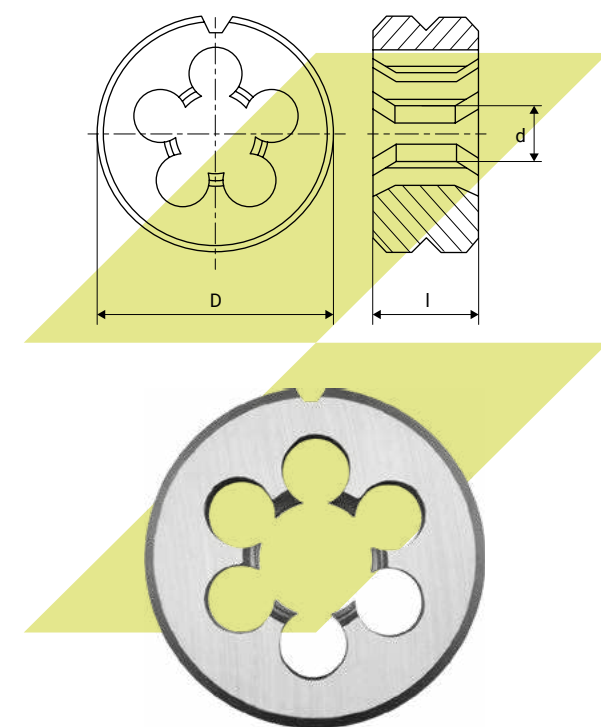
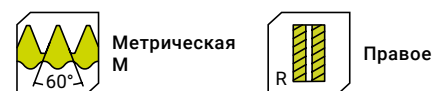
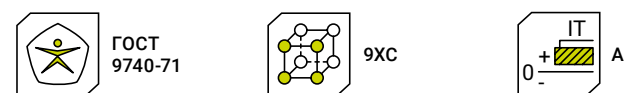
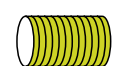

Артикул	Обозначение по ГОСТ	d, мм	P, мм	D, мм	l, мм
1130997	—	0,5	0,125	12,0	3,0
1130998	—	0,6	0,150	12,0	3,0
1425765	2650-1305	1,0	0,250	20,0	5,0
1335978	2650-1365	1,4	0,300	20,0	5,0
113824	—	1,7	0,350	12,0	3,0
113825	2650-1405	1,8	0,350	12,0	3,0
113830	2650-1445	2,2	0,450	12,0	3,0
104600	—	2,3	0,400	12,0	3,0
1337600	2650-1475	2,5	0,350	16,0	5,0
1143367	—	2,6	0,350	16,0	3,0
113831	—	2,6	0,450	16,0	3,0
1289683	2650-1497	3,0	0,350	20,0	5,0
1335984	2650-1513	3,5	0,350	20,0	5,0
113837	2650-1505	3,5	0,600	20,0	5,0
1379395	—	4,0	0,250	20,0	5,0
1337601	2650-1527	4,0	0,500	20,0	5,0
1258940	2650-1521	4,0	0,700	20,0	5,0
104620	2650-1543	4,5	0,500	20,0	5,0
1234857	2650-1551	5,0	0,800	20,0	7,0
104627	2650-1565	5,5	0,500	20,0	5,0
1240347	2650-1587	6,0	0,500	20,0	5,0
1263006	2650-1581	6,0	0,750	20,0	7,0
1178279	2650-1573	6,0	1,000	20,0	7,0
113848	2650-1603	7,0	0,750	25,0	9,0
1234858	2650-1595	7,0	1,000	25,0	9,0
1337602	2650-1625	8,0	1,000	25,0	9,0
1178280	2650-1617	8,0	1,250	25,0	9,0
1378502	—	8,0	1,500	25,0	9,0
1345705	2650-1671	9,0	0,500	25,0	9,0
113863	2650-1663	9,0	0,750	25,0	9,0
113864	2650-1655	9,0	1,000	25,0	9,0
1337534	2650-1701	10,0	0,750	30,0	11,0
1178283	2650-1693	10,0	1,000	30,0	11,0
1178282	2650-1685	10,0	1,250	30,0	11,0

Артикул	Обозначение по ГОСТ	d, мм	P, мм	D, мм	l, мм
1178281	2650-1677	10,0	1,500	30,0	11,0
1135657	2650-1737	11,0	0,500	30,0	8,0
113879	2650-1731	11,0	0,750	30,0	9,0
113881	2650-1715	11,0	1,500	30,0	9,0
113882	2650-1783	12,0	0,500	38,0	7,0
113884	2650-1775	12,0	0,750	38,0	7,0
1178286	2650-1767	12,0	1,000	38,0	10,0
1178285	2650-1761	12,0	1,250	38,0	10,0
1259000	2650-1753	12,0	1,500	38,0	10,0
1178284	2650-1745	12,0	1,750	38,0	14,0
1337603	2650-2007	14,0	0,500	38,0	10,0
1178290	2650-1813	14,0	1,000	38,0	10,0
1178289	2650-1805	14,0	1,250	38,0	10,0
1178288	2650-1797	14,0	1,500	38,0	10,0
1379520	—	14,0	1,750	38,0	10,0
1178287	2650-1791	14,0	2,000	38,0	14,0
1178588	2650-2023	15,0	1,000	38,0	10,0
1178589	2650-2015	15,0	1,500	38,0	10,0
1178294	2650-2061	16,0	0,500	45,0	14,0
1135660	2650-2053	16,0	0,750	45,0	10,0
1178293	2650-2045	16,0	1,000	45,0	14,0
1178590	—	16,0	1,250	45,0	14,0
1178292	2650-2037	16,0	1,500	45,0	14,0
1178291	2650-2031	16,0	2,000	45,0	18,0
1178591	2650-2075	17,0	1,000	45,0	14,0
1178592	2650-2067	17,0	1,500	45,0	14,0
1284583	2650-2121	18,0	0,500	45,0	10,0
113931	2650-2113	18,0	0,750	45,0	10,0
1178593	—	18,0	1,250	45,0	14,0
1178295	2650-2097	18,0	1,500	45,0	14,0
1178594	2650-2083	18,0	2,500	45,0	18,0
1178299	2650-2165	20,0	0,500	45,0	10,0
1178298	2650-2157	20,0	0,750	45,0	10,0
1178595	2650-2151	20,0	1,000	45,0	14,0
1178297	2650-2143	20,0	1,500	45,0	14,0
1289704	2650-2135	20,0	2,000	45,0	14,0
1178296	2650-2127	20,0	2,500	45,0	18,0
1178303	2650-2211	22,0	0,500	55,0	12,0
1178596	2650-2195	22,0	1,000	55,0	16,0

Артикул	Обозначение по ГОСТ	d, мм	P, мм	D, мм	l, мм
1178302	2650-2187	22,0	1,500	55,0	16,0
1178301	2650-2181	22,0	2,000	55,0	16,0
1178300	2650-2173	22,0	2,500	55,0	22,0
1178597	—	24,0	0,500	55,0	12,0
1178305	2650-2247	24,0	0,750	55,0	12,0
1240348	2650-2241	24,0	1,000	55,0	16,0
1240349	2650-2233	24,0	1,500	55,0	16,0
113970	2650-2225	24,0	2,000	55,0	16,0
1178304	2650-2217	24,0	3,000	55,0	22,0
1178621	2650-2271	25,0	1,000	55,0	16,0
1178622	2650-2263	25,0	1,500	55,0	16,0
1178623	2650-2255	25,0	2,000	55,0	16,0
1178624	2650-2277	26,0	1,500	55,0	16,0
1178625	—	27,0	0,500	65,0	14,0
1178610	2650-2301	27,0	1,500	65,0	18,0
113979	2650-2293	27,0	2,000	65,0	18,0
104794	2650-2285	27,0	3,000	65,0	25,0
1178626	2650-2337	28,0	1,000	65,0	18,0
1178627	2650-2331	28,0	1,500	65,0	18,0
1178628	2650-2323	28,0	2,000	65,0	18,0
1178629	—	30,0	0,500	65,0	14,0
1178849	2650-2383	30,0	0,750	65,0	14,0
1178636	2650-2375	30,0	1,000	65,0	18,0
1178642	2650-2367	30,0	1,500	65,0	18,0
113982	2650-2361	30,0	2,000	65,0	18,0
113983	2650-2353	30,0	3,000	65,0	25,0
1178649	2650-2345	30,0	3,500	65,0	25,0
1178630	2650-2397	32,0	1,500	65,0	18,0
1178850	2650-2391	32,0	2,000	65,0	18,0
1178313	2650-2443	33,0	0,750	65,0	14,0
1425129	2650-2435	33,0	1,000	65,0	14,0
1377421	2650-2427	33,0	1,500	65,0	18,0
1582525	2650-2421	33,0	2,000	65,0	18,0
1178312	2650-2413	33,0	3,000	65,0	25,0
1178311	2650-2405	33,0	3,500	65,0	25,0
1178632	2650-2451	35,0	1,500	65,0	18,0
1178633	2650-2487	36,0	1,000	65,0	14,0
1178634	2650-2481	36,0	1,500	65,0	18,0
1178635	2650-2473	36,0	2,000	65,0	18,0

Артикул	Обозначение по ГОСТ	d, мм	P, мм	D, мм	I, мм
113993	2650-2465	36,0	3,000	65,0	25,0
1178314	2650-2457	36,0	4,000	65,0	25,0
1178637	2650-2495	38,0	1,500	75,0	20,0
1178318	2650-2533	39,0	1,000	75,0	16,0
1178317	2650-2525	39,0	1,500	75,0	20,0
1178316	2650-2517	39,0	2,000	75,0	20,0
1240350	2650-2511	39,0	3,000	75,0	30,0
1178315	2650-2503	39,0	4,000	75,0	30,0
1377926	—	40,0	1,000	75,0	20,0
1178638	2650-2555	40,0	1,500	75,0	20,0
1582526	2650-2547	40,0	2,000	75,0	20,0
1178852	2650-2541	40,0	3,000	75,0	20,0
1178640	2650-2601	42,0	1,000	75,0	16,0
1582527	2650-2593	42,0	1,500	75,0	20,0
1178641	2650-2585	42,0	2,000	75,0	20,0
1178853	2650-2577	42,0	3,000	75,0	30,0
1178320	2650-2571	42,0	4,000	75,0	30,0
1178319	2650-2563	42,0	4,500	75,0	30,0
104843	2650-2637	45,0	1,500	90,0	22,0
104845	2650-2631	45,0	2,000	90,0	22,0
1135678	2650-2623	45,0	3,000	90,0	36,0
114004	2650-2615	45,0	4,000	90,0	36,0
104849	2650-2607	45,0	4,500	90,0	36,0
104851	2650-2691	48,0	1,000	90,0	18,0
104853	2650-2683	48,0	1,500	90,0	22,0
104855	2650-2675	48,0	2,000	90,0	22,0
114010	2650-2667	48,0	3,000	90,0	36,0
1135679	2650-2661	48,0	4,000	90,0	36,0
1135680	2650-2653	48,0	5,000	90,0	36,0
1178854	2650-2713	50,0	1,500	90,0	22,0
104861	2650-2757	52,0	1,000	90,0	18,0
104863	2650-2751	52,0	1,500	90,0	22,0
114014	2650-2743	52,0	2,000	90,0	22,0
104867	2650-2735	52,0	3,000	90,0	36,0
114016	2650-2727	52,0	4,000	90,0	36,0
104869	2650-2721	52,0	5,000	90,0	36,0

Артикул	Обозначение по ГОСТ	d, мм	P, мм	D, мм	I, мм
1178644	2650-2823	55,0	1,500	105,0	22,0
1178855	2650-2815	55,0	2,000	105,0	22,0
1178856	2650-2807	55,0	3,000	105,0	36,0
1178647	2650-2801	55,0	4,000	105,0	36,0
1178648	2650-2861	56,0	1,500	105,0	22,0
1178857	2650-2853	56,0	2,000	105,0	22,0
1178858	2650-2845	56,0	3,000	105,0	36,0
1178651	2650-2837	56,0	4,000	105,0	36,0
1178652	2650-2831	56,0	5,500	105,0	36,0
1178653	2650-2897	60,0	1,500	105,0	22,0
1178654	2650-2891	60,0	2,000	105,0	22,0
1178655	2650-2883	60,0	3,000	105,0	36,0
1178656	2650-2875	60,0	4,000	105,0	36,0
1178657	2650-2867	60,0	5,500	105,0	36,0
1178658	2650-2927	62,0	1,500	105,0	22,0
1178659	2650-2921	62,0	2,000	105,0	22,0
1178660	2650-2913	62,0	3,000	105,0	36,0
1178661	2650-2905	62,0	4,000	105,0	36,0
1178662	2650-2965	64,0	1,500	120,0	22,0
1178663	2650-2957	64,0	2,000	120,0	22,0
1178664	2650-2951	64,0	3,000	120,0	36,0
1178665	2650-2943	64,0	4,000	120,0	36,0
1178666	2650-2935	64,0	6,000	120,0	36,0
1178667	2650-3005	65,0	1,500	120,0	22,0
1178668	2650-2987	65,0	2,000	120,0	22,0
1178669	2650-2981	65,0	3,000	120,0	36,0
1178670	2650-2973	65,0	4,000	120,0	36,0
1178671	2650-3043	68,0	1,500	120,0	22,0
1178672	2650-3035	68,0	2,000	120,0	22,0
1178673	2650-3021	68,0	4,000	120,0	36,0
1178674	2650-3013	68,0	6,000	120,0	36,0
1419529	—	70,0	1,500	120,0	20,0
1419533	—	70,0	2,000	120,0	20,0
1220047	—	72,0	1,500	120,0	22,0
1416352	—	75,0	2,000	120,0	22,0

Плашки круглые для метрической резьбы, M

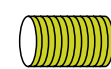

ГОСТ 9740-71

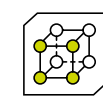

P6M5

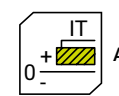

IT A

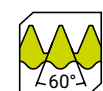

Метрическая M

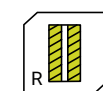

Правое

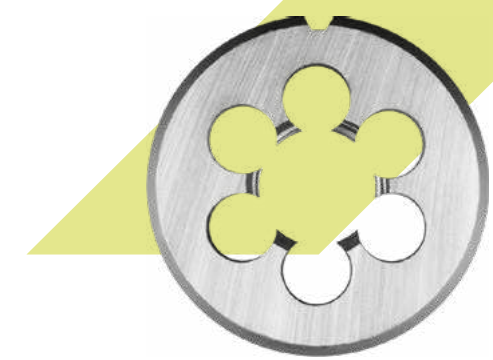
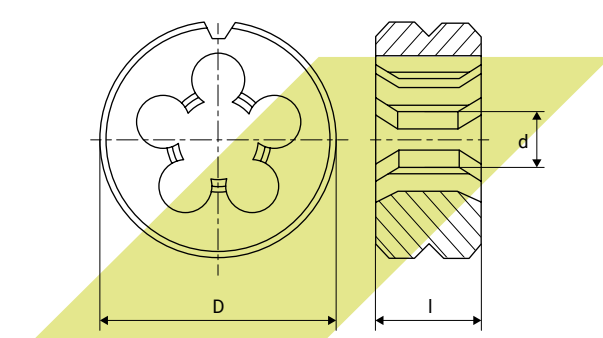

Артикул	Обозначение по ГОСТ	d, мм	P, мм	D, мм	I, мм
1140493	2650-1305	1,0	0,25	20,0	5,0
1175986	2650-1325	1,1	0,25	20,0	5,0
1258401	2650-1355	1,2	0,20	20,0	5,0
1140494	2650-1345	1,2	0,25	20,0	5,0
1140495	2650-1365	1,4	0,30	20,0	5,0
1140496	2650-1385	1,6	0,35	20,0	5,0
1175987	—	1,7	0,35	20,0	5,0
1175988	2650-1405	1,8	0,35	20,0	5,0
1182020	—	1,9	0,35	20,0	5,0
1238386	2650-1435	2,0	0,25	16,0	5,0
1140497	2650-1425	2,0	0,40	16,0	5,0
1238385	2650-1445	2,2	0,45	16,0	5,0
1175989	2650-1465	2,5	0,45	16,0	5,0
1261491	2650-1497	3,0	0,35	20,0	5,0
1140498	2650-1485	3,0	0,50	20,0	5,0
1175990	2650-1505	3,5	0,60	20,0	5,0
1150756	2650-1527	4,0	0,50	20,0	5,0
1140499	2650-1521	4,0	0,70	20,0	5,0
1175991	2650-1535	4,5	0,75	20,0	7,0
1150757	2650-1557	5,0	0,50	20,0	5,0
1150770	2650-1551	5,0	0,80	20,0	7,0
1150758	2650-1587	6,0	0,50	20,0	5,0
1150759	2650-1581	6,0	0,75	20,0	7,0
1140500	2650-1573	6,0	1,00	20,0	7,0
1150760	2650-1641	8,0	0,50	25,0	9,0
1150761	2650-1633	8,0	0,75	25,0	9,0
1150762	2650-1625	8,0	1,00	25,0	9,0
1140501	2650-1617	8,0	1,25	25,0	9,0
1345706	2650-1671	9,0	0,50	25,0	9,0
1261494	2650-1707	10,0	0,50	30,0	8,0
1261496	2650-1701	10,0	0,75	30,0	11,0
1150763	2650-1693	10,0	1,00	30,0	11,0
1150764	2650-1685	10,0	1,25	30,0	11,0
1140502	2650-1677	10,0	1,50	30,0	11,0

Нарезание и накатывание резьбы

Нарезание и накатывание резьбы

Артикул	Обозначение по ГОСТ	d, мм	P, мм	D, мм	I, мм
1253856	2650-1775	12,0	0,75	38,0	10,0
1150765	2650-1767	12,0	1,00	38,0	10,0
1150766	2650-1761	12,0	1,25	38,0	10,0
1343080	2650-1753	12,0	1,50	38,0	10,0
1140503	2650-1745	12,0	1,75	38,0	14,0
1343232	2650-1813	14,0	1,00	38,0	10,0
1150767	2650-1805	14,0	1,25	38,0	10,0
1150768	2650-1797	14,0	1,50	38,0	10,0
1178587	—	14,0	2,00	45,0	18,0
1343081	2650-2037	16,0	1,50	45,0	14,0
1140504	2650-2031	16,0	2,00	45,0	18,0
104725	2650-2113	18,0	0,75	45,0	14,0
1179993	2650-2097	18,0	1,50	45,0	14,0
1345708	2650-2091	18,0	2,00	45,0	14,0

Артикул	Обозначение по ГОСТ	d, мм	P, мм	D, мм	I, мм
1140505	2650-2083	18,0	2,50	45,0	18,0
1220048	2650-2151	20,0	1,00	45,0	14,0
1343082	2650-2143	20,0	1,50	45,0	14,0
1140506	2650-2127	20,0	2,50	45,0	18,0
1343083	2650-2187	22,0	1,50	55,0	16,0
1343233	2650-2173	22,0	2,50	55,0	22,0
1140507	2650-2217	24,0	3,00	55,0	22,0
1220049	2650-2301	27,0	1,50	65,0	18,0
1418336	2650-2293	27,0	2,00	65,0	18,0
1220050	2650-2481	36,0	1,50	65,0	18,0
1180000	2650-2473	36,0	2,00	65,0	18,0
1418337	2650-2517	39,0	2,00	75,0	20,0
1150771	2650-2853	56,0	2,00	105,0	22,0

Плашки круглые для метрической резьбы, М

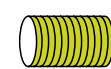

ГОСТ 9740-71



9XC

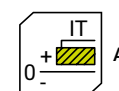

IT A

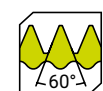

Метрическая М

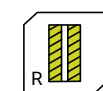

Правое

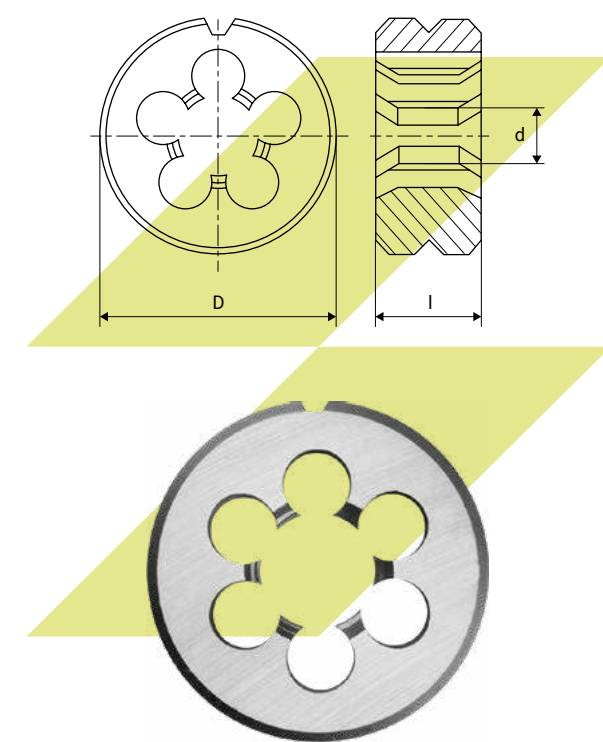

Артикул	Обозначение по ГОСТ	d, мм	P, мм	D, мм	I, мм
1335980	2650-1365	1,4	0,30	20,0	5,0
1335981	2650-1385	1,6	0,35	20,0	5,0
1335982	2650-1425	2,0	0,40	16,0	5,0
1335983	2650-1465	2,5	0,45	16,0	5,0
1289682	2650-1497	3,0	0,35	20,0	5,0
1289684	2650-1485	3,0	0,50	20,0	5,0
1335985	2650-1513	3,5	0,35	20,0	5,0
1335986	2650-1527	4,0	0,50	20,0	5,0
1289685	2650-1521	4,0	0,70	20,0	5,0
1335991	2650-1557	5,0	0,50	20,0	5,0
1335987	2650-1551	5,0	0,80	20,0	7,0
1335988	2650-1587	6,0	0,50	20,0	5,0
1289686	2650-1581	6,0	0,75	20,0	7,0
1289714	2650-1573	6,0	1,00	20,0	7,0
1337481	2650-1641	8,0	0,50	25,0	9,0
1337482	2650-1633	8,0	0,75	25,0	9,0
1289687	2650-1625	8,0	1,00	25,0	9,0
1289688	2650-1617	8,0	1,25	25,0	9,0
1337483	2650-1701	10,0	0,75	30,0	11,0
1289689	2650-1693	10,0	1,00	30,0	11,0
1289690	2650-1685	10,0	1,25	30,0	11,0
1289691	2650-1677	10,0	1,50	30,0	11,0
1289692	2650-1761	12,0	1,25	38,0	10,0
1289693	2650-1753	12,0	1,50	38,0	10,0
1289694	2650-1745	12,0	1,75	38,0	14,0
1289695	2650-1813	14,0	1,00	38,0	10,0
1289696	2650-1805	14,0	1,25	38,0	10,0
1289697	2650-1797	14,0	1,50	38,0	10,0
1289698	2650-1791	14,0	2,00	38,0	14,0
1289699	2650-2037	16,0	1,50	45,0	14,0
1289700	2650-2031	16,0	2,00	45,0	18,0
1289701	2650-2097	18,0	1,50	45,0	14,0
1289702	2650-2083	18,0	2,50	45,0	18,0
1289703	2650-2143	20,0	1,50	45,0	14,0

Нарезание и накатывание резьбы

Нарезание и накатывание резьбы

Артикул	Обозначение по ГОСТ	d, мм	P, мм	D, мм	I, мм
1289705	2650-2127	20,0	2,50	45,0	18,0
1289706	2650-2187	22,0	1,50	55,0	16,0
1289707	2650-2173	22,0	2,50	55,0	22,0
1289708	2650-2233	24,0	1,50	55,0	16,0
1289709	2650-2217	24,0	3,00	55,0	22,0

Артикул	Обозначение по ГОСТ	d, мм	P, мм	D, мм	I, мм
1289710	2650-2301	27,0	1,50	65,0	18,0
1289711	2650-2367	30,0	1,50	65,0	18,0
1289712	2650-2345	30,0	3,50	65,0	25,0
1289713	2650-2457	36,0	4,00	65,0	25,0

Плашки круглые для метрической резьбы, М

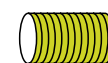

ГОСТ 9740-71



P6M5

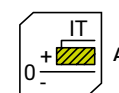

IT A



Метрическая М



Правое R

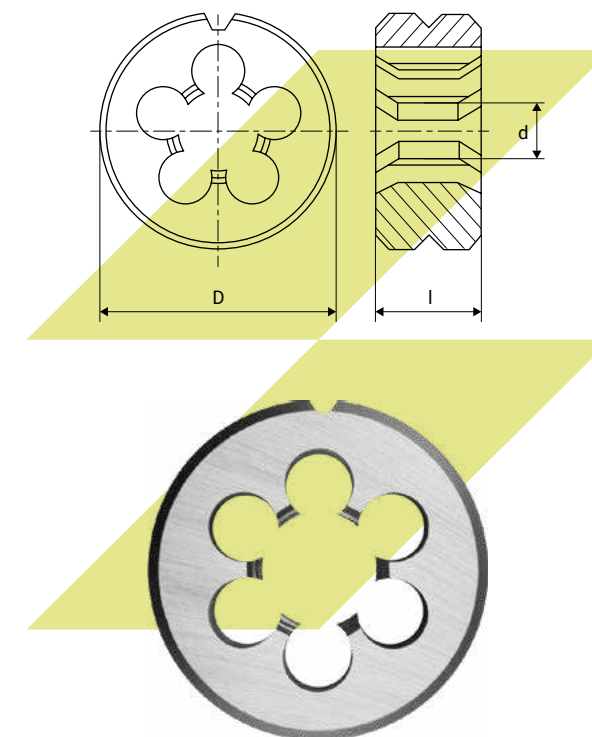

Артикул	Обозначение по ГОСТ	d, мм	P, мм	D, мм	I, мм
1323516	2650-1425	2,0	0,40	16,0	5,0
1261490	2650-1465	2,5	0,45	16,0	5,0
1178158	2650-1485	3,0	0,50	20,0	5,0
1178159	2650-1521	4,0	0,70	20,0	5,0
1178160	2650-1551	5,0	0,80	20,0	7,0
1378524	2650-1587	6,0	0,50	20,0	5,0
1178161	2650-1573	6,0	1,00	20,0	7,0
1323518	2650-1595	7,0	1,00	25,0	9,0
1252492	2650-1625	8,0	1,00	25,0	9,0
1178163	2650-1617	8,0	1,25	25,0	9,0
1181983	2650-1655	9,0	1,00	25,0	9,0
1323519	2650-1647	9,0	1,25	25,0	9,0
1242948	2650-1707	10,0	0,50	30,0	8,0
1242949	2650-1701	10,0	0,75	30,0	11,0
1172906	2650-1693	10,0	1,00	30,0	11,0
1265342	2650-1685	10,0	1,25	30,0	11,0
1178164	2650-1677	10,0	1,50	30,0	11,0
1323520	2650-1723	11,0	1,00	30,0	11,0
1323521	2650-1715	11,0	1,50	30,0	11,0
1181984	2650-1775	12,0	0,75	38,0	10,0
1253794	2650-1767	12,0	1,00	38,0	10,0
1242950	2650-1761	12,0	1,25	38,0	10,0
1253795	2650-1753	12,0	1,50	38,0	10,0
1178167	2650-1745	12,0	1,75	38,0	14,0
1242951	2650-2001	14,0	0,75	38,0	10,0
1234628	2650-1813	14,0	1,00	38,0	10,0
1181985	2650-1805	14,0	1,25	38,0	10,0
1178169	2650-1797	14,0	1,50	38,0	10,0
1323522	2650-1791	14,0	2,00	38,0	14,0
1181987	2650-2045	16,0	1,00	45,0	14,0
1234629	2650-2037	16,0	1,50	45,0	14,0
1181986	2650-2031	16,0	2,00	45,0	18,0
1181988	2650-2105	18,0	1,00	45,0	14,0
1234705	2650-2097	18,0	1,50	45,0	14,0

Артикул	Обозначение по ГОСТ	d, мм	P, мм	D, мм	I, мм
1265344	2650-2091	18,0	2,00	45,0	14,0
1265345	2650-2083	18,0	2,50	45,0	18,0
1240311	2650-2143	20,0	1,50	45,0	14,0
1181989	2650-2127	20,0	2,50	45,0	18,0
1253796	2650-2195	22,0	1,00	55,0	16,0
1181991	2650-2187	22,0	1,50	55,0	16,0
1181990	2650-2181	22,0	2,00	55,0	16,0
1242952	2650-2173	22,0	2,50	55,0	22,0
1253797	2650-2241	24,0	1,00	55,0	16,0
1242953	2650-2233	24,0	1,50	55,0	16,0
1181993	2650-2225	24,0	2,00	55,0	16,0

Артикул	Обозначение по ГОСТ	d, мм	P, мм	D, мм	I, мм
1181992	2650-2217	24,0	3,00	55,0	22,0
1253798	2650-2307	27,0	1,00	65,0	18,0
1234630	2650-2301	27,0	1,50	65,0	18,0
1181994	2650-2367	30,0	1,50	65,0	18,0
1234631	2650-2427	33,0	1,50	65,0	18,0
1181995	2650-2421	33,0	2,00	65,0	18,0
1181996	—	33,0	2,50	65,0	18,0
1234632	2650-2533	39,0	1,00	75,0	16,0
1234706	2650-2525	39,0	1,50	75,0	20,0
1181997	2650-2555	40,0	1,50	75,0	20,0
1180001	2650-2593	42,0	1,50	75,0	20,0

Плашки круглые для метрической резьбы, М

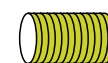

ГОСТ 9740-71



P6M5

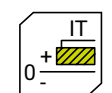

IT A

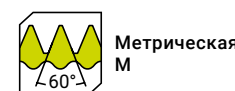

Метрическая М



Правое R

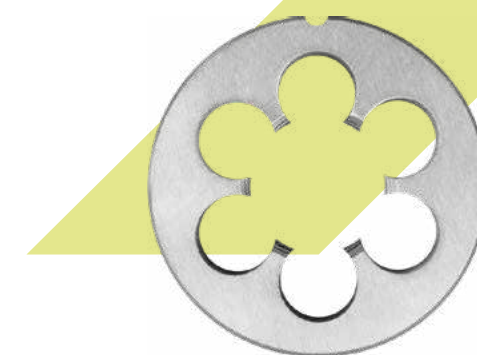
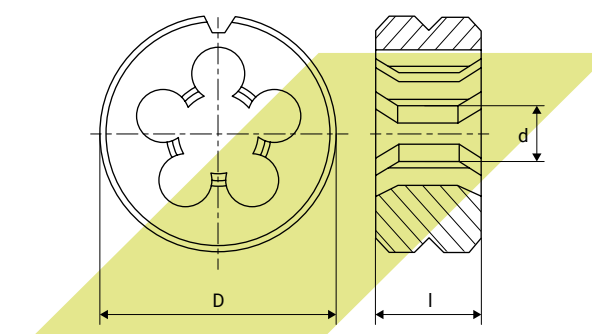

Артикул	Обозначение по ГОСТ	d, мм	P, мм	D, мм	I, мм
1243924	2650-1425	2,0	0,40	16,0	5,0
1253788	2650-1465	2,5	0,45	16,0	5,0
1150772	2650-1485	3,0	0,50	20,0	5,0
1150773	2650-1521	4,0	0,70	20,0	5,0
1150774	2650-1551	5,0	0,80	20,0	7,0
1150775	2650-1573	6,0	1,00	20,0	7,0
1323517	2650-1595	7,0	1,00	25,0	9,0
1178162	2650-1625	8,0	1,00	25,0	9,0
1150776	2650-1617	8,0	1,25	25,0	9,0
1261495	2650-1701	10,0	0,75	30,0	11,0
1242946	2650-1693	10,0	1,00	30,0	11,0
1265343	2650-1685	10,0	1,25	30,0	11,0
1150777	2650-1677	10,0	1,50	30,0	11,0
1378528	2650-1775	12,0	0,75	38,0	10,0
1178165	2650-1767	12,0	1,00	38,0	10,0
1150778	2650-1753	12,0	1,50	38,0	10,0
1178166	2650-1745	12,0	1,75	38,0	14,0
1178168	2650-1813	14,0	1,00	38,0	10,0
1150779	2650-1797	14,0	1,50	38,0	10,0
1323523	2650-1791	14,0	2,00	38,0	14,0
1181976	2650-2045	16,0	1,00	45,0	14,0
1178170	2650-2037	16,0	1,50	45,0	14,0
1181977	2650-2031	16,0	2,00	45,0	18,0
1253789	2650-2105	18,0	1,00	45,0	14,0
1178171	2650-2097	18,0	1,50	45,0	14,0
1181978	2650-2083	18,0	2,50	45,0	18,0
1261499	2650-2151	20,0	1,00	45,0	14,0
1178172	2650-2143	20,0	1,50	45,0	14,0
1253790	2650-2195	22,0	1,00	55,0	16,0
1181979	2650-2187	22,0	1,50	55,0	16,0
1253791	2650-2241	24,0	1,00	55,0	16,0
1234626	2650-2233	24,0	1,50	55,0	16,0
1150780	2650-2315	27,0	0,75	65,0	18,0
1253792	2650-2307	27,0	1,00	65,0	18,0

Артикул	Обозначение по ГОСТ	d, мм	P, мм	D, мм	I, мм
1256896	2650-2301	27,0	1,50	65,0	18,0
1253793	2650-2367	30,0	1,50	65,0	18,0
1181980	2650-2361	30,0	2,00	65,0	18,0
1178612	2650-2435	33,0	1,00	65,0	18,0

Артикул	Обозначение по ГОСТ	d, мм	P, мм	D, мм	I, мм
1178616	2650-2427	33,0	1,50	65,0	18,0
1234627	2650-2421	33,0	2,00	65,0	18,0
1242947	2650-2487	36,0	1,00	65,0	14,0
1378512	2650-2473	36,0	2,00	65,0	18,0

Плашки круглые для метрической резьбы, левые, М

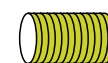

ГОСТ 9740-71



9ХС

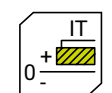

IT A

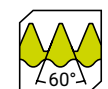

Метрическая М



Левое L

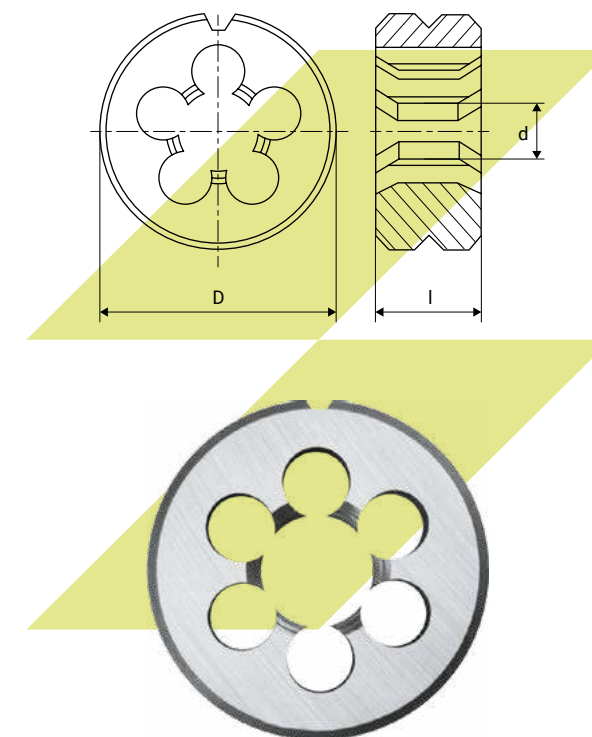

Артикул	Обозначение по ГОСТ	d, мм	P, мм	D, мм	I, мм
1379519	2650-1498	3,0	0,35	20,0	5,0
104608	2650-1486	3,0	0,50	16,0	3,0
1378366	2650-1528	4,0	0,50	20,0	5,0
104616	2650-1522	4,0	0,70	20,0	5,0
1378367	2650-1558	5,0	0,50	20,0	5,0
1441811	2650-1552	5,0	0,80	20,0	7,0
1178335	2650-1588	6,0	0,50	20,0	5,0
1378745	2650-1588	6,0	0,50	20,0	5,0
1178334	2650-1582	6,0	0,75	20,0	7,0
1379187	2650-1574	6,0	1,00	20,0	7,0
1178333	2650-1574	6,0	1,00	20,0	7,0
1379240	2650-1596	7,0	1,00	25,0	9,0
1178338	2650-1642	8,0	0,50	25,0	9,0
1178337	2650-1634	8,0	0,75	25,0	9,0
1178336	2650-1626	8,0	1,00	25,0	9,0
1178585	2650-1618	8,0	1,25	25,0	9,0
1178343	2650-1708	10,0	0,50	30,0	8,0
1178342	2650-1702	10,0	0,75	30,0	11,0
1178341	2650-1694	10,0	1,00	30,0	11,0
1178340	2650-1686	10,0	1,25	30,0	11,0
1178339	2650-1678	10,0	1,50	30,0	11,0
1178349	2650-1784	12,0	0,50	38,0	10,0
1178348	2650-1776	12,0	0,75	38,0	10,0
1178347	2650-1768	12,0	1,00	38,0	10,0
1178346	2650-1762	12,0	1,25	38,0	10,0
1178345	2650-1754	12,0	1,50	38,0	10,0
1178344	2650-1746	12,0	1,75	38,0	14,0
1178354	2650-2008	14,0	0,50	38,0	10,0
1178353	2650-2002	14,0	0,75	38,0	10,0
1178352	2650-1814	14,0	1,00	38,0	10,0
1178351	2650-1806	14,0	1,25	38,0	10,0
1345707	2650-1798	14,0	1,50	38,0	10,0
1178350	2650-1792	14,0	2,00	38,0	14,0
1178359	2650-2062	16,0	0,50	45,0	10,0

Артикул	Обозначение по ГОСТ	d, мм	P, мм	D, мм	I, мм
1178358	2650-2054	16,0	0,75	45,0	10,0
1178357	2650-2046	16,0	1,00	45,0	14,0
1178356	2650-2038	16,0	1,50	45,0	14,0
1178355	2650-2032	16,0	2,00	45,0	18,0
1178364	2650-2122	18,0	0,50	45,0	10,0
1178363	2650-2114	18,0	0,75	45,0	10,0
1178362	2650-2098	18,0	1,50	45,0	14,0
1178361	2650-2092	18,0	2,00	45,0	14,0
1178360	2650-2084	18,0	2,50	45,0	18,0
1178370	2650-2166	20,0	0,50	45,0	10,0
1178369	2650-2158	20,0	0,75	45,0	10,0
1178368	2650-2152	20,0	1,00	45,0	14,0
1178367	2650-2144	20,0	1,50	45,0	14,0
1178366	2650-2136	20,0	2,00	45,0	14,0
1178365	2650-2128	20,0	2,50	45,0	18,0
1178376	2650-2212	22,0	0,50	55,0	12,0
1178375	2650-2204	22,0	0,75	55,0	12,0
1178374	2650-2196	22,0	1,00	55,0	16,0
1178373	2650-2188	22,0	1,50	55,0	16,0
1178372	2650-2182	22,0	2,00	55,0	16,0
1178371	2650-2174	22,0	2,50	55,0	22,0
1178379	2650-2248	24,0	0,75	55,0	12,0
1178378	2650-2242	24,0	1,00	55,0	16,0
1220908	2650-2234	24,0	1,50	55,0	16,0
1345709	2650-2226	24,0	2,00	55,0	16,0
1178377	2650-2218	24,0	3,00	55,0	22,0
1178607	2650-2316	27,0	0,75	65,0	14,0
1178609	2650-2308	27,0	1,00	65,0	18,0
1178615	2650-2302	27,0	1,50	65,0	18,0
1178618	2650-2294	27,0	2,00	65,0	18,0
1178620	2650-2286	27,0	3,00	65,0	25,0
1178631	2650-2384	30,0	0,75	65,0	14,0

Артикул	Обозначение по ГОСТ	d, мм	P, мм	D, мм	I, мм
1178639	2650-2376	30,0	1,00	65,0	18,0
1178643	2650-2368	30,0	1,50	65,0	18,0
1178645	2650-2362	30,0	2,00	65,0	18,0
1178646	2650-2354	30,0	3,00	65,0	25,0
1178650	2650-2346	30,0	3,50	65,0	25,0
1178396	2650-2444	33,0	0,75	65,0	14,0
1178395	2650-2436	33,0	1,00	65,0	14,0
1178394	2650-2428	33,0	1,50	65,0	18,0
1178393	2650-2422	33,0	2,00	65,0	18,0
1178392	2650-2414	33,0	3,00	65,0	25,0
1178391	2650-2406	33,0	3,50	65,0	25,0
1178400	2650-2488	36,0	1,00	65,0	14,0
1178399	2650-2482	36,0	1,50	65,0	18,0
1220830	2650-2474	36,0	2,00	65,0	18,0
1178398	2650-2466	36,0	3,00	65,0	25,0
1178851	2650-2458	36,0	4,00	65,0	25,0
1178405	2650-2534	39,0	1,00	75,0	16,0
1178404	2650-2526	39,0	1,50	75,0	20,0
1178403	2650-2518	39,0	2,00	75,0	20,0
1178402	2650-2512	39,0	3,00	75,0	30,0
1178401	2650-2504	39,0	4,00	75,0	30,0
1234859	2650-2602	42,0	1,00	75,0	16,0
1234860	2650-2594	42,0	1,50	75,0	20,0
1234861	2650-2586	42,0	2,00	75,0	20,0
1234862	2650-2578	42,0	3,00	75,0	30,0
1178406	2650-2564	42,0	4,50	75,0	30,0
1178407	2650-2608	45,0	4,50	90,0	36,0
1178408	2650-2654	48,0	5,00	90,0	36,0
1335909	2650-2744	52,0	2,00	90,0	22,0
1179918	2650-2736	52,0	3,00	90,0	36,0
1178409	2650-2722	52,0	5,00	90,0	36,0

Плашки круглые для трубной цилиндрической резьбы, G

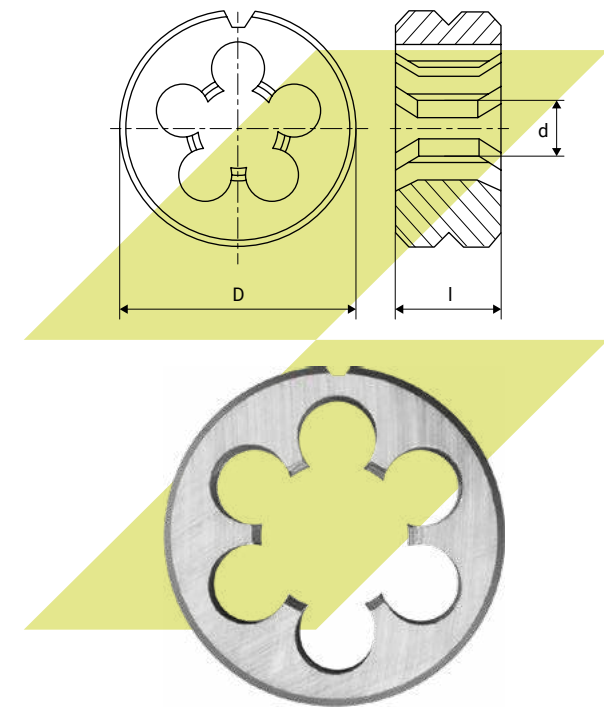
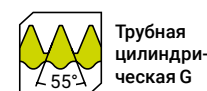
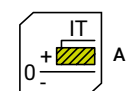
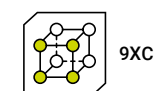
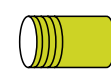

Артикул	Обозначение по ГОСТ	D, дюйм	d, мм	число ниток на 1"	P, мм	D, мм	I, мм
1178322	2654-1251	1/16	7,723	28	0,907	25,0	9,0
1418011	2654-0151	1/8	9,728	28	0,907	30,0	11,0
1335910	2654-0153	1/4	13,157	19	1,337	38,0	10,0
1425766	2654-0155	3/8	16,662	19	1,337	45,0	14,0
1178579	2654-0157	1/2	20,995	14	1,814	45,0	14,0
114032	2654-0161	5/8	22,911	14	1,814	55,0	16,0
1178582	2654-0163	3/4	26,441	14	1,814	55,0	16,0
114034	2654-0165	7/8	30,201	14	1,814	65,0	18,0
1178580	2654-0167	1	33,249	11	2,309	65,0	18,0
1417539	2654-0171	1 1/8	37,987	11	2,309	75,0	20,0
1178578	2654-0173	1 1/4	41,910	11	2,309	75,0	20,0
114023	2654-0175	1 3/8	44,323	11	2,309	90,0	22,0

Нарезание и накатывание резьбы

Нарезание и накатывание резьбы

Артикул	Обозначение по ГОСТ	D, дюйм	d, мм	число ниток на 1"	P, мм	D, мм	I, мм
1253461	2654-0253	1 3/4	53,746	11	2,309	105,0	22,0
1178581	2654-0255	2	59,614	11	2,309	105,0	22,0
1252582	2654-0271	2 1/4	65,710	11	2,309	120,0	22,0

Плашки круглые для трубной цилиндрической резьбы, G

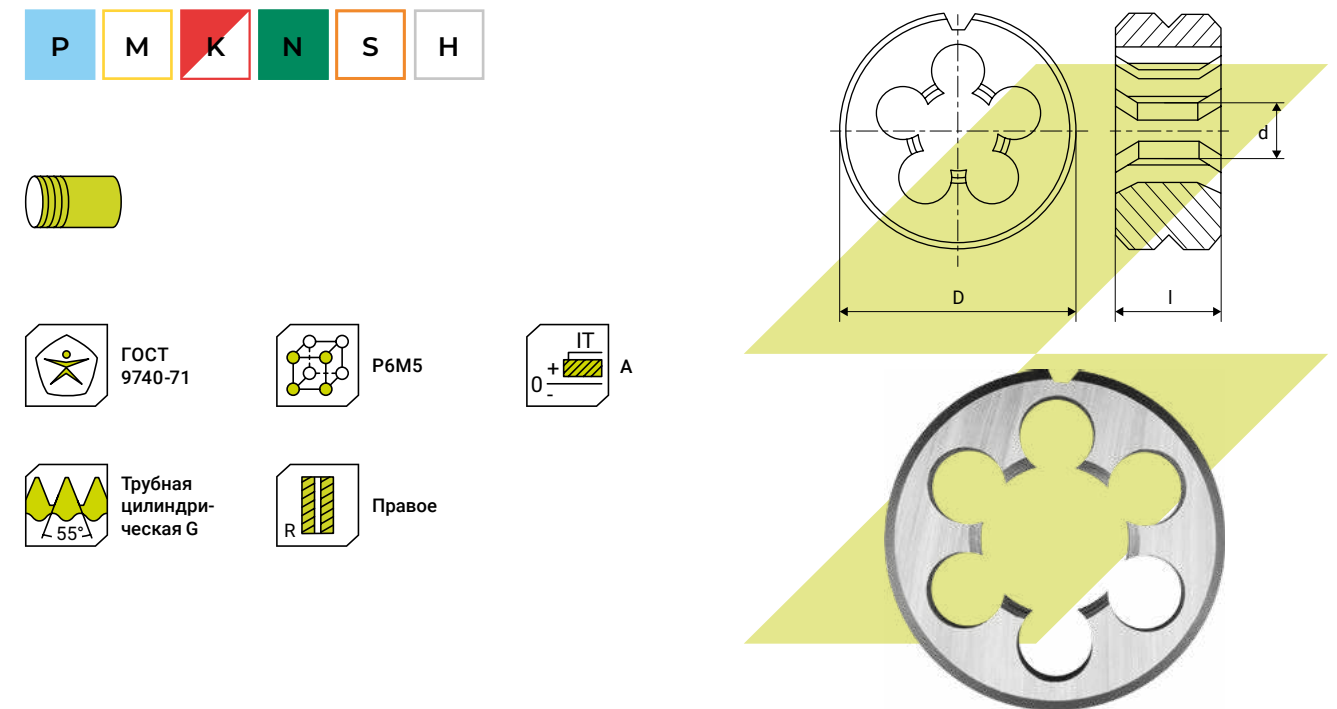

Артикул	Обозначение по ГОСТ	D, дюйм	d, мм	число ниток на 1"	P, мм	D, мм	I, мм
1326125	2654-0151	1/8	9,728	28	0,907	30,0	11,0
1326126	2654-0153	1/4	13,157	19	1,337	38,0	10,0
1326128	2654-0155	3/8	16,662	19	1,337	45,0	14,0
1326127	2654-0157	1/2	20,995	14	1,814	45,0	14,0
1326130	2654-0161	5/8	22,911	14	1,814	55,0	16,0
1326129	2654-0163	3/4	26,441	14	1,814	55,0	16,0
1326131	2654-0165	7/8	30,201	14	1,814	65,0	18,0
1326132	2654-0167	1	33,249	11	2,309	65,0	18,0
1326138	2654-0171	1 1/8	37,987	11	2,309	75,0	20,0
1326133	2654-0173	1 1/4	41,910	11	2,309	75,0	20,0
1326135	2654-0175	1 3/8	44,323	11	2,309	90,0	22,0
1326134	2654-0177	1 1/2	47,803	11	2,309	90,0	22,0
1326136	2654-0253	1 3/4	53,746	11	2,309	105,0	22,0
1326137	2654-0255	2	59,614	11	2,309	105,0	22,0

Плашки круглые для трубной цилиндрической резьбы, левые, G

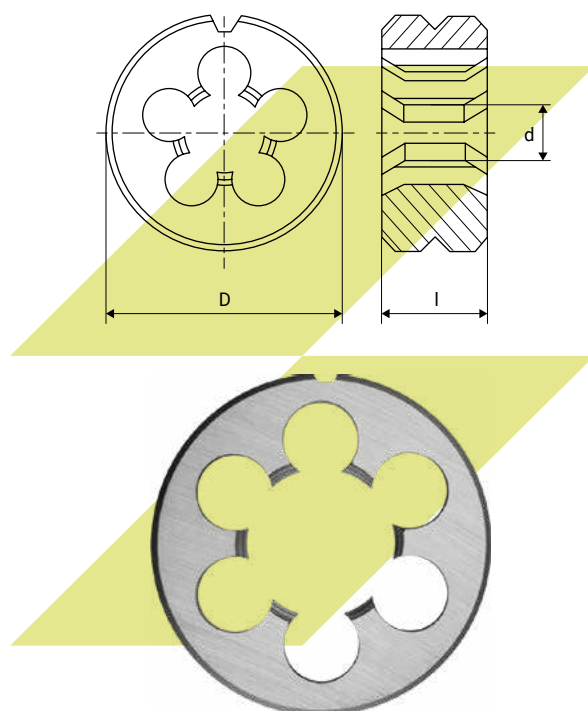
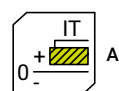
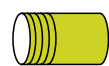

Артикул	Обозначение по ГОСТ	D, дюйм	d, мм	число ниток на 1"	P, мм	D, мм	l, мм
1252569	2654-0252	1/16	7,723	28	0,907	25,0	9,0
1252570	2654-0152	1/8	9,728	28	0,907	30,0	11,0
1252571	2654-0154	1/4	13,157	19	1,337	38,0	10,0
1252572	2654-0156	3/8	16,662	19	1,337	45,0	14,0
1220046	2654-0158	1/2	20,995	14	1,814	45,0	14,0
1252573	2654-0162	5/8	22,911	14	1,814	55,0	16,0
1253458	2654-0164	3/4	26,441	14	1,814	55,0	16,0
1252574	2654-0166	7/8	30,201	14	1,814	65,0	18,0
1252575	2654-0168	1	33,249	11	2,309	65,0	18,0
1252576	2654-0172	1 1/8	37,987	11	2,309	75,0	20,0
1252577	2654-0174	1 1/4	41,910	11	2,309	75,0	20,0
1252578	2654-0176	1 3/8	44,323	11	2,309	90,0	22,0

Артикул	Обозначение по ГОСТ	D, дюйм	d, мм	число ниток на 1"	P, мм	D, мм	l, мм
1252579	2654-0178	1 1/2	47,803	11	2,309	90,0	22,0
1252580	2654-0254	1 3/4	53,746	11	2,309	105,0	22,0
1252581	2654-0256	2	59,614	11	2,309	105,0	22,0
1252583	2654-0272	2 1/4	65,710	11	2,309	105,0	22,0

Плашки круглые для конической дюймовой резьбы, К

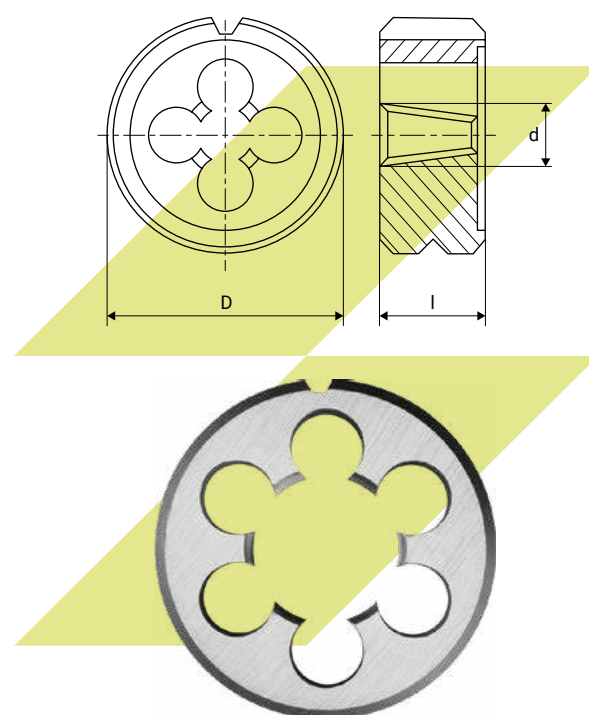
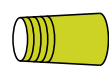

Плашки круглые для трубной конической резьбы, R

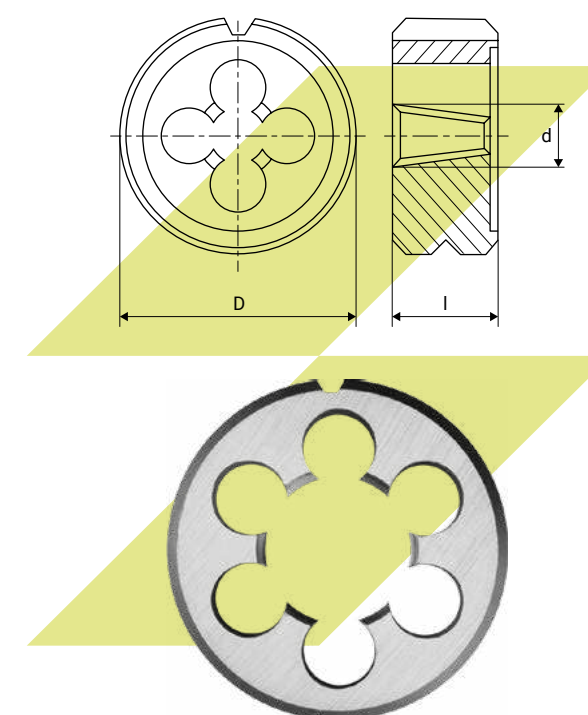
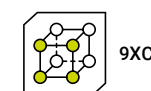
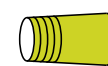

Артикул	Обозначение по ГОСТ	D, дюйм	число ниток на 1"	P, мм	D, мм	I, мм
1178330	2684-0001	1/16	27,0	0,941	25,0	9,0
1584571	2684-0002	1/8"	27,0	0,941	30,0	12,0
1337599	2684-0003	1/4	18,0	1,411	38,0	17,0
1178331	2684-0004	3/8	18,0	1,411	45,0	18,0
1178332	2684-0005	1/2	14,0	1,814	45,0	24,0
1425020	2684-0006	3/4	14,0	1,814	55,0	24,0
1584572	2684-0008	1 1/4	11,5	2,209	75,0	30,0
113801	2684-0009	1 1/2	11,5	2,209	90,0	30,0
113806	2684-0010	2	11,5	2,209	105,0	32,0

Артикул	Обозначение по ГОСТ	D, дюйм	d, мм	число ниток на 1"	P, мм	D, мм	I, мм
1178327	2684-0101	1/16	7,142	28	0,941	25,0	9,0
1476973	2684-0011	1/8	9,147	28	0,907	30,0	12,0
1583527	2684-0013	3/8	15,806	19	1,337	48,0	18,0
1178583	2684-0014	1/2	19,793	14	1,814	55,0	22,0
1476974	2684-0015	3/4	25,279	14	1,814	55,0	24,0
1178584	2684-0016	1	31,770	11	2,309	65,0	28,0
1345711	2684-0017	1 1/4	40,431	11	2,309	75,0	30,0
1345710	2684-0018	1 1/2	46,324	11	2,309	90,0	30,0
114044	2684-0019	2	58,135	11	2,309	105,0	36,0
1174024	—	3 1/4	—	—	—	—	—

Плашки круглые дюймовые резьба Витворта, BSF

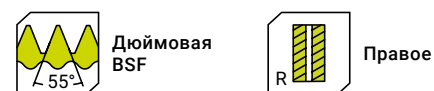
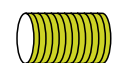

Артикул	D, дюйм	Число ниток на 1"	D, мм	I, мм
1237476	3/16	32	20,0	7,0
1237472	1/4	26	20,0	7,0
1237478	5/16	22	25,0	9,0
1237475	3/8	20	30,0	11,0
1237480	7/16	18	30,0	11,0
1237471	1/2	16	38,0	14,0
1237481	9/16	16	38,0	14,0
1237477	5/8	14	45,0	18,0
1237473	11/16	14	45,0	18,0
1237474	3/4	12	45,0	18,0
1237479	7/8	11	55,0	22,0
1237485	1	10	55,0	22,0
1237484	1 1/8	9	65,0	25,0
1237483	1 1/4	9	65,0	25,0
1237482	1 1/2	8	75,0	30,0
1237486	2	7	90,0	36,0

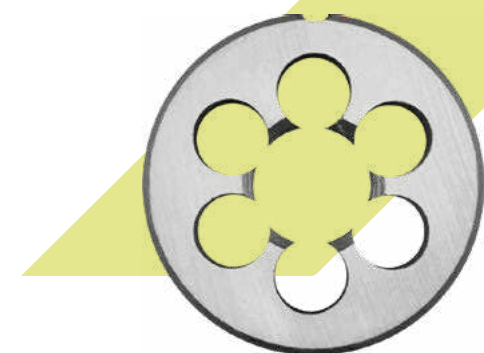
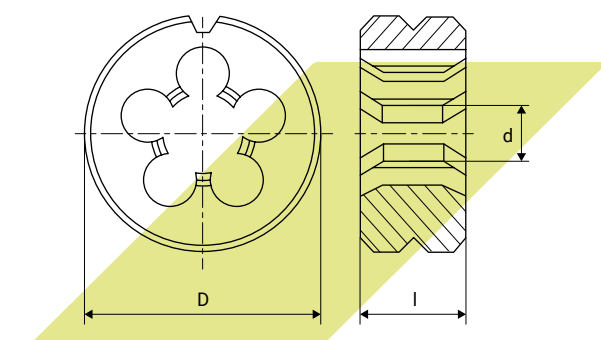

Плашки круглые дюймовые резьба Витворта, BSW

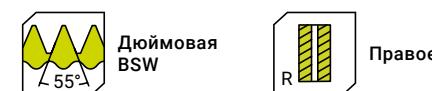
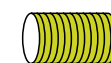

Артикул	D, дюйм	Число ниток на 1"	D, мм	I, мм
1237489	1/8	40	20,0	5,0
1237493	3/16	24	20,0	7,0
1237488	1/4	20	20,0	7,0
1237495	5/16	18	25,0	9,0
1237492	3/8	16	30,0	11,0
1237497	7/16	14	30,0	11,0
1237487	1/2	12	38,0	14,0
1237498	9/16	12	38,0	14,0
1237494	5/8	11	45,0	18,0
1237490	11/16	11	45,0	18,0
1237491	3/4	10	45,0	18,0
1237496	7/8	9	55,0	22,0
1237504	1	8	55,0	22,0
1237501	1 1/8	7	65,0	25,0
1237500	1 1/4	7	65,0	25,0
1237503	1 3/8	6	65,0	25,0
1237499	1 1/2	6	75,0	30,0
1237502	1 3/4	5	90,0	36,0
1237505	2	4,5	90,0	36,0

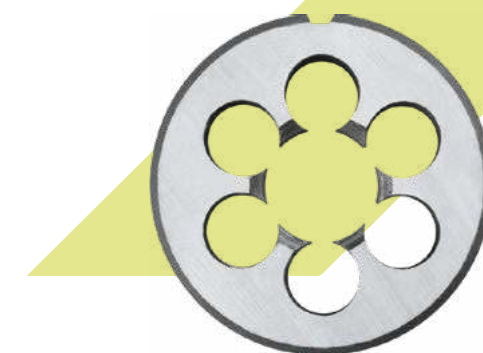
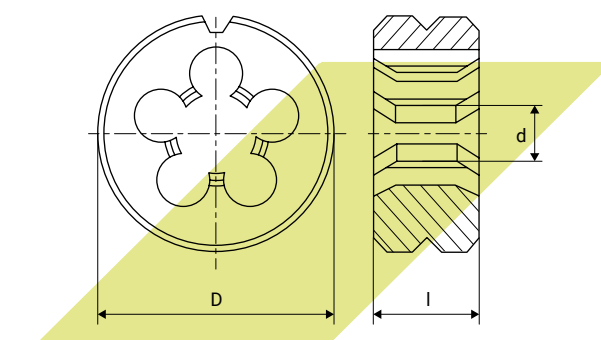

Набор резьбонарезной в металлическом футляре

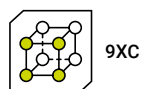

9XC



Артикул		Мин. диаметр d1, мм	Макс. диаметр d2, мм	Кол-во предметов
1343306		3	12	32
1343307		3	12	40
1343308		6	24	45

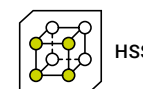

Набор резьбонарезной в металлическом футляре



HSS

Артикул		Мин. диаметр d1, мм	Макс. диаметр d2, мм	Кол-во предметов
1805313		3	12	32



Ролики резьбонакатные к головке ВНГН для метрической резьбы, М

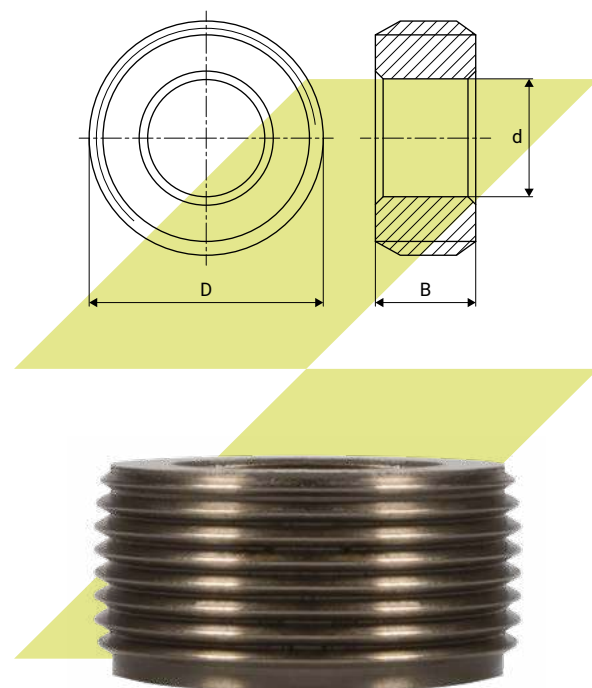

Артикул	Комплект, шт.	Условное обозначение головки	d, мм	P, мм	Размер резьбы, мм	D, мм	B, мм
0106663	3	ВНГН-2	11,5	0,70	4	18,3	10
0106664	3	ВНГН-2	11,5	0,80	5	19,5	10
0106665	3	ВНГН-2	11,5	1,00	6–7	18,4	10
0106666	3	ВНГН-3М	22,0	1,00	8–12	40,3	18
1103583	3	ВНГН-3М	22,0	1,25	8–12	40,6	18
0106667	3	ВНГН-3М	22,0	1,50	10–12	41,0	18
1103254	3	ВНГН-3М	22,0	1,75	12	40,0	18
0106668	3	ВНГН-3М	22,0	1,00	14–16	36,1	18
0106669	3	ВНГН-3М	22,0	1,50	14–16	36,0	18
1103255	3	ВНГН-3М	22,0	2,00	14–16	37,0	18
0106671	3	ВНГН-4М	34,0	1,50	16–22	69,8	25
0116327	3	ВНГН-4М	34,0	2,50	18–22	69,9	25
0106672	3	ВНГН-4М	34,0	1,50	24–27	63,0	25
0116326	4	ВНГН-4М	34,0	2,00	24–27	64,8	25
1326102	4	ВНГН-4М	34,0	3,00	24–27	64,6	25

Ролики резьбонакатные к плашкам НП для метрической резьбы, М

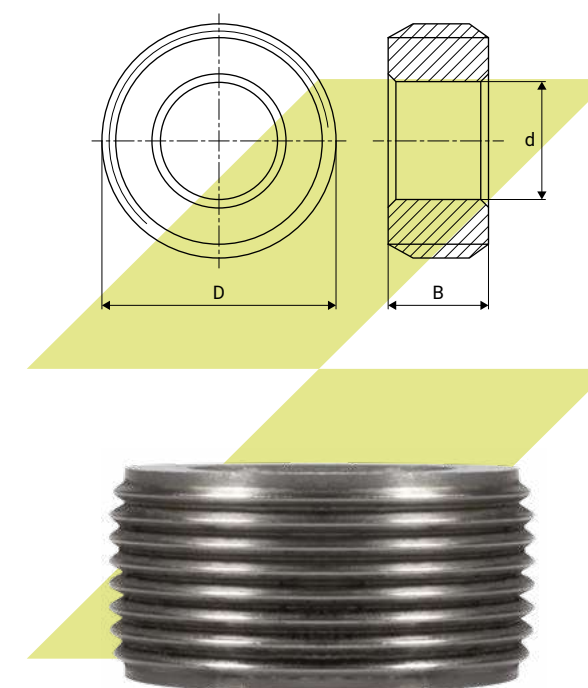

Артикул	Комплект, шт.	Условное обозначение головки	d, мм	P, мм	Размер резьбы, мм	D, мм	B, мм
1476940	3	НП-1	11,5	0,70	4	18,4	6
1331106	3	НП-1	11,5	0,80	5	19,6	6
0106675	3	НП-2	22,0	1,00	8–12	38,9	10
0106676	3	НП-2	22,0	1,25	8–12	38,9	10
0106677	3	НП-2	22,0	1,25	8	38,9	10
0106678	3	НП-2	22,0	1,50	10–16	37,5	10
0106680	3	НП-2	22,0	1,75	12	36,4	10
1131057	3	НП-2	22,0	1,00	14–16	35,9	10
0116329	3	НП-2	22,0	2,00	14–16	37,1	10
0106682	3	НП-3	22,0	1,50	18–22	37,5	10
0116328	4	НП-4	22,0	1,50	27–33	39,6	10
0106683	4	НП-4	22,0	2,00	27–33	40,1	10

Ролики резьбонакатные для метрической резьбы, М

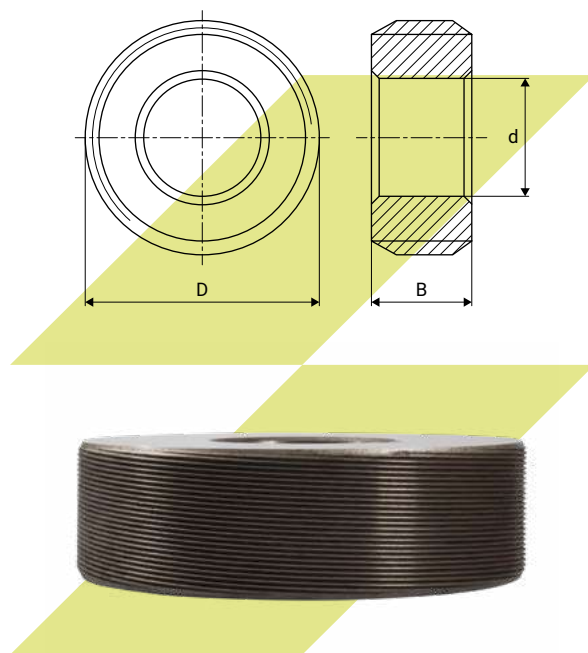
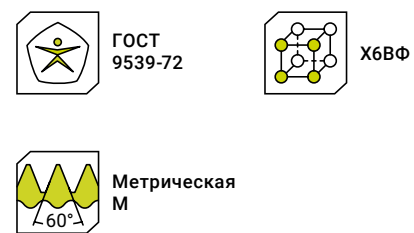

Артикул	Комплект, шт.	Обозначение по ГОСТ	d, мм	P, мм	Размер резьбы, мм	D, мм	B, мм
1226819	2	1417-0305	54	0,50	3	139,388	32
1104267	2	1417-0334	54	0,70	4	142,244	40
1102659	2	1417-0335	54	0,70	4	142,244	50
1254897	2	1417-0370	54	0,80	5	143,822	40
1583150	2	1417-0371	54	0,80	5	143,822	50
1103574	2	1417-0409	54	1,00	6	140,876	40
1128843	2	1417-0413	63	1,00	6	140,876	40
1102660	2	1417-0411	54	1,00	6	140,876	63
0115384	2	1417-0407	45	1,00	6	96,876	63
0115004	2	1417-0465	54	1,00	8	132,876	40
1103257	2	1417-0478	54	1,25	8	144,482	50
0117078	2	1417-0479	54	1,25	8	144,482	63

Артикул	Комплект, шт.	Обозначение по ГОСТ	d, мм	P, мм	Размер резьбы, мм	D, мм	B, мм
1178706	2	1417-0483	63	1,25	8	144,482	63
0115002	2	1417-0585	54	1,50	10	145,280	40
1128842	2	1417-0589	63	1,50	10	145,280	40
0117082	2	1417-0587	54	1,50	10	145,280	63
0117081	2	1417-0591	63	1,50	10	145,280	63
1181945	2	1417-0593	80	1,50	10	199,436	40
1109201	2	1417-0686	54	1,00	12	136,776	63
0117777	2	1417-0704	54	1,25	12	134,978	40
0118689	2	1417-0706	54	1,25	12	134,978	63
1102653	2	1417-0724	54	1,50	12	134,978	40
0115387	2	1417-0742	45	1,75	12	98,777	63
0115001	2	1417-0744	54	1,75	12	131,366	40
1181946	2	1417-0748	63	1,75	12	131,366	40
0117083	2	1417-0745	54	1,75	12	131,366	50
0117084	2	1417-0746	54	1,75	12	131,366	63
0106689	2	1417-0750	63	1,75	12	131,366	63
1418574	2	1417-0754	80	1,75	12	196,544	63
1134871	2	1417-0804	54	1,25	14	132,602	40
1102652	2	1417-0824	54	1,50	14	131,366	40
1326440	2	1417-0946	54	1,50	16	136,098	63
1105689	2	1417-0951	63	1,50	16	136,098	80
1102654	2	1417-0960	45	2,00	16	104,000	40
1134870	2	1417-0964	54	2,00	16	133,461	40
1102822	2	1417-0967	54	2,00	16	134,000	80
1418575	2	1417-0974	80	2,00	16	192,265	63
1477026	2	1417-1818	80	2,00	16	192,265	80
1135244	2	1417-1066	54	1,50	18	137,072	63
0115268	2	1417-1070	63	1,50	18	137,072	63
1179647	2	1417-1067	54	1,50	18	137,072	80
1105688	2	1417-1071	63	1,50	18	137,072	80
1134869	2	1417-1106	54	2,50	18	132,450	63
1103047	2	1417-1110	63	2,50	18	132,450	63
0117774	2	1417-1145	54	1,50	20	134,046	63
0117090	2	1417-1187	54	2,50	20	130,074	100
0106690	2	1417-1184	54	2,50	20	130,074	50
1102601	2	1417-1185	54	2,50	20	130,074	63
1107017	2	1417-1189	63	2,50	20	130,074	63
1102602	2	1417-1186	54	2,50	20	130,074	80
1417878	2	-	80	2,50	22	199,000	79

Артикул	Комплект, шт.	Обозначение по ГОСТ	d, мм	P, мм	Размер резьбы, мм	D, мм	B, мм
1227818	2	1417-1309	63	1,50	24	139,020	63
0115388	2	1417-1325	54	3,00	24	137,358	63
0106692	2	1417-1345	54	3,00	24	134,034	63
0117776	2	1417-1349	63	3,00	24	134,034	63
1417848	2	-	80	3,00	24	199,000	79
1108922	2	1417-1353	80	3,00	24	200,187	63
1181947	2	1417-1354	80	3,00	24	200,187	80
1134872	2	1417-1464	54	1,50	27	130,994	50
0115389	2	1417-1465	54	1,50	27	130,994	63
1109759	2	1417-1474	80	1,50	27	180,046	80
1418576	2	1417-1495	80	2,00	27	206,760	100
0115386	2	1417-1505	54	3,00	27	126,983	63
1107720	2	1417-1509	63	3,00	27	126,983	63
1417879	2	-	80	3,00	27	199,000	79
0117091	2	1417-1605	54	2,00	30	144,657	63
1418577	2	1417-1615	80	2,00	30	202,059	100
1131584	2	1417-1629	63	3,50	30	140,651	63
1417849	2	-	80	3,50	30	168,000	92
1477027	2	1417-0975	80	3,00	36	171,983	100
1417880	2	-	80	4,00	36	168,000	92

Ролики резьбонакатные для метрической резьбы, М

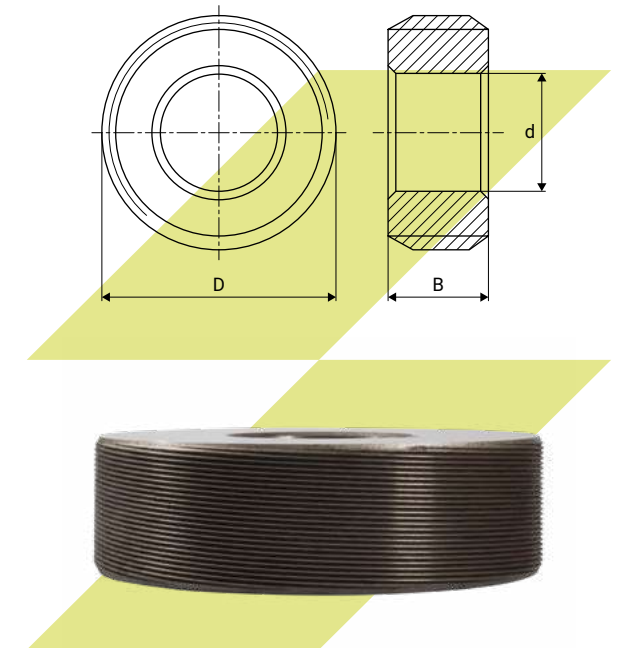
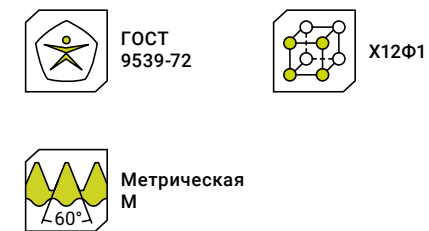

Артикул	Комплект, шт.	Обозначение по ГОСТ	d, мм	P, мм	Размер резьбы, мм	D, мм	B, мм
1134868	2	1417-0411	54	1,0	6	139,676	63
0115003	2	1417-0549	63	1,0	10	131,476	40
1417463	2	1417-0587	54	1,5	10	145,280	63
0117773	2	1417-1148	63	1,5	20	134,046	50
0106691	2	1417-1185	54	2,5	20	130,074	63
0115501	2	1417-1794	80	2,0	36	174,657	80

Ролики резьбонакатные для метрической резьбы, М

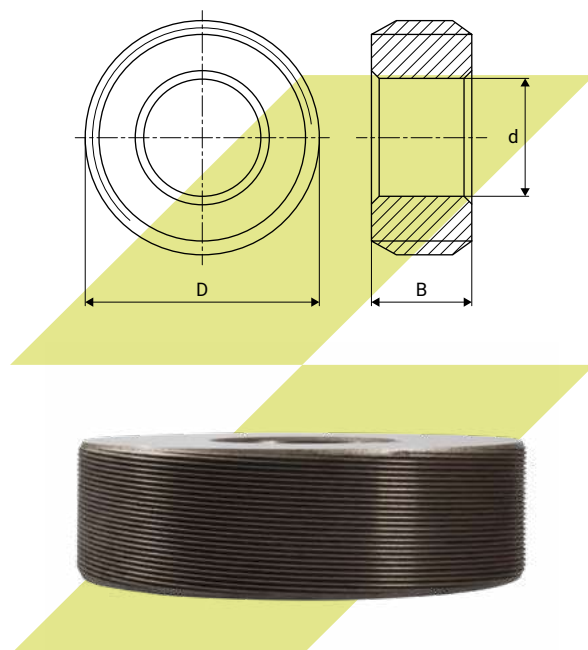
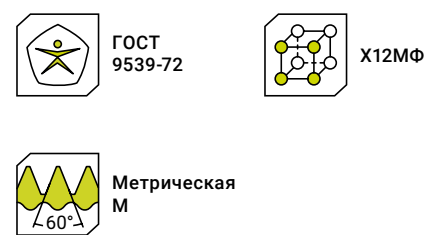

Артикул	Комплект, шт.	Обозначение по ГОСТ	d, мм	P, мм	Размер резьбы, мм	D, мм	B, мм
1258303	2	1417-0309	63	0,50	3	139,000	40
1258305	2	1417-0337	63	0,70	4	142,000	40
1258306	2	1417-0373	63	0,80	5	144,000	40
1258307	2	1417-0413	63	1,00	6	140,000	40
1258308	2	1417-0483	63	1,25	8	144,000	63
1258309	2	1417-0591	63	1,50	10	145,000	63
1269525	2	1417-0593	80	1,50	10	199,436	40
1267121	2	1417-0686	54	1,00	12	136,776	63
1265394	2	1417-0704	54	1,25	12	146,166	40
1269501	2	1417-0747	54	1,75	12	131,366	80
1269502	2	1417-0847	54	2,00	14	128,162	80
0117775	2	1417-1266	54	2,50	22	144,074	80
1269503	2	1417-1327	54	2,00	24	137,358	100

Ролики резьбонакатные для метрической резьбы, М

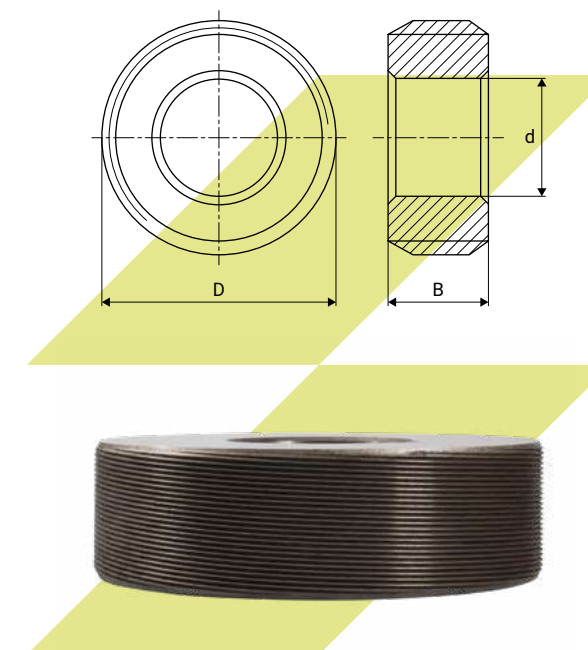
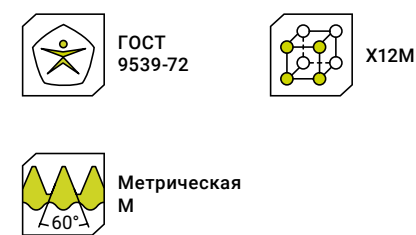

Артикул	Комплект, шт.	Обозначение по ГОСТ	d, мм	P, мм	Размер резьбы, мм	D, мм	B, мм
1102522	2	1417-0306	54	0,5	3	139,388	40
1102553	2	1417-0337	63	0,7	4	142,244	40
1583149	2	1417-0335	54	0,7	4	142,244	50
1103576	2	1417-0370	54	0,8	5	143,822	40
1102554	2	1417-0373	63	0,8	5	143,822	40
0106687	2	1417-0405	45	1,0	6	96,876	40
0106688	2	1417-0581	45	1,5	10	91,124	40
1583151	2	1417-0726	54	1,5	12	133,176	63
0117087	2	1417-0844	54	2,0	14	128,162	40
0117086	2	1417-0846	54	2,0	14	128,162	63
1134867	2	1417-0925	54	1,0	16	138,726	50
0118690	2	1417-0946	54	1,5	16	136,098	63

Артикул		Комплект, шт.	Обозначение по ГОСТ	d, мм	P, мм	Размер резьбы, мм	D, мм	B, мм
0117088	●	2	1417-0964	54	2,0	16	133,461	40
1109160	●	2	1417-0965	54	2,0	16	133,461	50
0117089	●	2	1417-0966	54	2,0	16	133,461	63
1103258	●	2	1417-0970	63	2,0	16	133,461	63
1104297	●	2	1417-6005	63	2,0	16	177,566	120
0115005	●	2	1417-0973	80	2,0	16	192,265	50
1109161	●	2	1417-1105	54	2,5	18	132,450	50
0115385	●	2	1417-1106	54	2,5	18	132,450	63
1583137	●	2	1417-1790	63	2,0	36	139,956	80

Вороток для круглых плашек

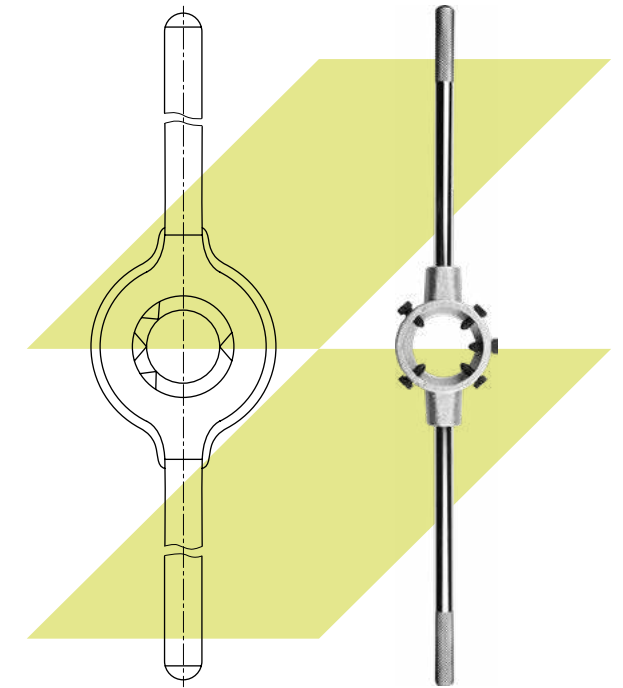

Артикул		D плашки, мм	l плашки, мм	D _{min} плашки, мм	D _{max} плашки, мм	№
1343284	●	16,0	5,0	1,0	2,5	№ 1
1343285	●	20,0	5,0	3,0	4,0	№ 2
1343286	●	20,0	7,0	5,0	6,0	№ 3
1343287	●	25,0	9,0	8,0	9,0	№ 4
1343288	●	30,0	11,0	10,0	11,0	№ 5
1343289	●	38,0	14,0	12,0	14,0	№ 7
1343290	●	45,0	18,0	16,0	20,0	№ 9
1343291	●	55,0	22,0	22,0	24,0	№11
1343292	●	65,0	25,0	27,0	36,0	№13
1343293	●	75,0	30,0	39,0	42,0	№15
1343294	●	90,0	36,0	45,0	52,0	№17
1343295	●	105,0	36,0	55,0	62,0	№19

Воротки для метчиков

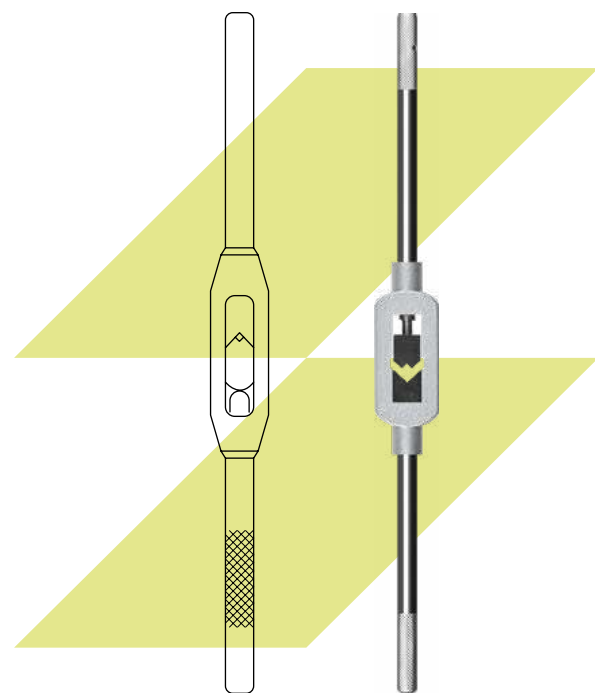

Артикул		D _{min} метчика, мм	D _{max} метчика, мм	№	a _{min} , мм	a _{max} , мм
1343296	●	1,0	8,0	№0	2,0	5,0
1343297	●	1,0	10,0	№1	2,0	6,0
1343298	●	1,0	12,0	№1,5	2,5	8,0
1343299	●	3,5	12,0	№2	4,0	9,0
1343300	●	5,0	20,0	№3	4,9	12,0
1343301	●	9,0	27,0	№4	5,0	16,0
1441569	●	10,0	42,0	№6	7,0	25,0
1533069	●	12,0	56,0	—	7,1	28,0
1612899	●	14,0	75,0	—	7,1	35,5
1343302	●	13,0	32,0	№5	7,0	20,0
112904	●	32,0	64,0	—	32,0	64,0

Для заметок

Area with horizontal dashed lines for notes.

Нарезание и накатывание резьбы

Нарезание и накатывание резьбы



Отрезные работы

Фрезы отрезные-прорезные	550
Из быстрорежущей стали	550
Из твердого сплава	564
Пилы ленточные	567
Быстрорежущие	567
Пилы сегментные	572
Пилы	572
Сегменты	573
Полотна машинные	574

Фрезы отрезные-прорезные

Фрезы отрезные-прорезные предназначены для прорезки прямых шлицев, пазов и отрезных работ в изделиях из чугуна, черных, цветных металлов, сплавов стали. Используются для оснащения универсальных фрезерных и токарных станков, в том числе с ЧПУ, а также могут быть установлены на бормашину, гравер, дрель или ручной фрезер.

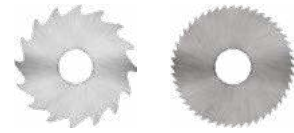

Пилы ленточные

Пилы ленточные применяются для резки металла, заготовок, фигурной и прямолинейной резки. Изготовлены из биметалла, благодаря чему отличаются высокой производительностью, прочностью и гибкостью. Образуют качественный, узкий и идеально ровный пропил.



Пилы сегментные

Сегментные пилы предназначены для отрезки заготовок из стали и чугуна на фрезерно-отрезных станках общего и специального назначения. Пилы изготавливаются сборными и состоят из диска, на котором с помощью заклепок закреплены сегменты, рабочая часть которых должны изготавливаться из быстрорежущей стали, устойчивой к коррозии. Диск используется многократно, сегменты при износе заменяются. Сегменты являются расходным материалом. Крепятся диски сегментной пилы с помощью заклепок. Изготовлены из быстрорежущей стали, устойчивой к коррозии.



Полотна машинные

Полотна машинные по металлу используются для резки труб, швеллеров, уголков и другого сортового проката из металла. Изделия оснащены отверстиями для закрепления на раме. На полотнах имеется одна режущая сторона.



Условные обозначения

Основные размеры

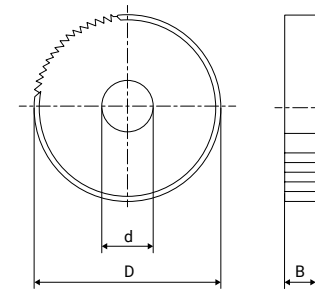

D – диаметр рабочей части
d – диаметр посадки
B – ширина



Обозначение стандарта



Обозначение инструментального материала

Тип обработки



Для канавки/отрезки

Тип зубьев



Тип 1

Мелкий зуб



Тип 2

Средний зуб



Тип 3

Крупный зуб

Наличие инструмента



На складе в Нижнем Новгороде



Под заказ

Обрабатываемый материал

P Стали

M Нержавеющая сталь

K Чугуны

N Цветные металлы

S Жаропрочные сплавы

H Закаленная сталь

Оптимальное применение

Возможное применение

Не применяется

Фрезы отрезные из быстрорежущей стали

	Прорезные и отрезные				
Вид обработки					
Стандарт	ГОСТ 2679-2014	ГОСТ 2679-2014	ГОСТ 2679-2014	ГОСТ 16230-81	ГОСТ 2679-2014
Тип зуба	Тип 1 (мелкий зуб)	Тип 2 (средний зуб)	Тип 3 (крупный зуб)	Тип 3 (крупный зуб)	Тип 1 (мелкий зуб)
Материал	P6M5	P6M5	P6M5	P6M5	P18
Диапазон	20,0–315,0	32,0–315,0	50,0–315,0	63,0–200,0	32,0–200,0
Страница	550	553	556	558	559

Фрезы отрезные из быстрорежущей стали

Вид обработки		
Стандарт	ГОСТ 2679-2014	ГОСТ 2679-2014
Тип зуба	Тип 2 (средний зуб)	Тип 3 (крупный зуб)
Материал	P18	P18
Диапазон	50,0–200,0	125,0
Страница	561	563

Фрезы отрезные из твердого сплава

Вид обработки	
Стандарт	DIN 1837 DIN 1838
Тип зуба	Тип 1 (мелкий зуб)
Материал	BK8
Диапазон	25,0–80,0
Страница	564

Ленточные пилы

Материал	M42-T	M51-B	M51-T
Страница	567	570	571

Пилы сегментные

	Пилы	Сегменты
Стандарт	ГОСТ 4047-82	ГОСТ 4047-82
Материал	P6M5	P6M5
Страница	572	573

Полотна

	Полотна машинные односторонние
Материал	P6M5
Страница	574

Фрезы прорезные и отрезные из быстрорежущей стали с мелким зубом

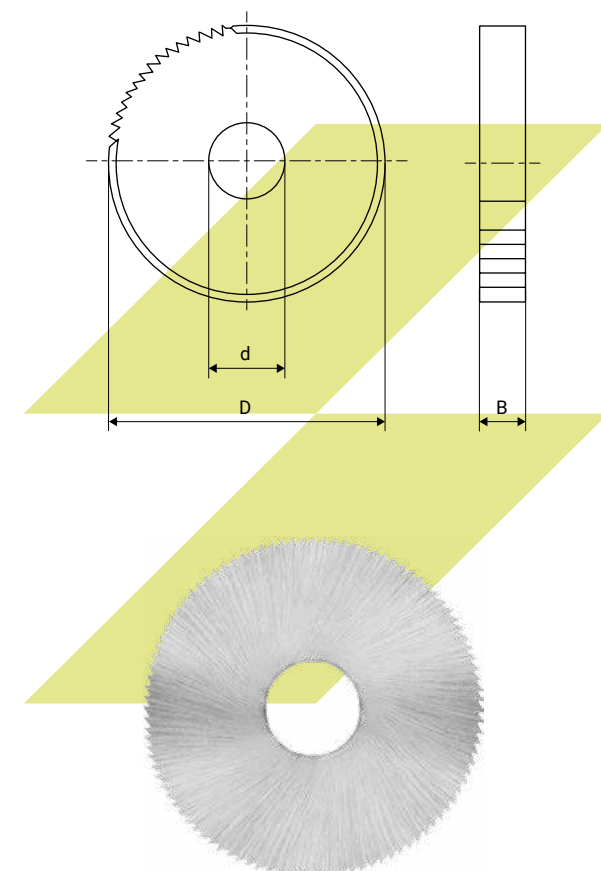
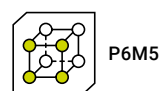

Артикул	Обозначение по ГОСТ	D, мм	B, мм	d, мм	Z, шт
1220856	2254-0642	20,0	0,20	5,0	80
1220857	2254-0644	20,0	0,25	5,0	64
1424861	2254-0646	20,0	0,30	5,0	48
1220858	2254-0646	20,0	0,30	5,0	64
1220859	2254-0648	20,0	0,40	5,0	64
1220860	2254-0652	20,0	0,50	5,0	48
1220861	2254-0654	20,0	0,60	5,0	48
1220862	2254-0656	20,0	0,80	5,0	48
1220863	2254-0658	20,0	1,00	5,0	40
1220864	2254-0662	20,0	1,20	5,0	40
1220865	2254-0664	20,0	1,40	5,0	40
1220866	2254-0666	20,0	1,60	5,0	40
1220867	2254-0668	20,0	2,00	5,0	32
1220868	2254-0672	20,0	2,50	5,0	32
1284904	2254-0674	25,0	0,20	8,0	80
1284898	2254-0676	25,0	0,25	8,0	80
1284905	2254-0678	25,0	0,30	8,0	80
1284906	2254-0682	25,0	0,40	8,0	64
1284899	2254-0684	25,0	0,50	8,0	64
1284907	2254-0686	25,0	0,60	8,0	64
1284908	2254-0688	25,0	0,80	8,0	48
1284900	2254-0692	25,0	1,00	8,0	48
1284909	2254-0694	25,0	1,20	8,0	48
1284910	2254-0696	25,0	1,40	8,0	48
1284911	2254-0698	25,0	1,60	8,0	40
1284912	2254-0702	25,0	2,00	8,0	40
1284913	2254-0704	25,0	2,50	8,0	40
1284914	2254-0706	25,0	2,80	8,0	40
1284915	2254-0708	25,0	3,00	8,0	40
1172959	—	32,0	0,20	8,0	80
1177813	2254-0716	32,0	0,30	8,0	80
1172972	2254-0718	32,0	0,40	8,0	80
1256876	2254-0722	32,0	0,50	8,0	80
1174841	2254-0724	32,0	0,60	8,0	64

Артикул	Обозначение по ГОСТ	D, мм	B, мм	d, мм	Z, шт
1174843	2254-0726	32,0	0,80	8,0	64
1177814	—	32,0	0,90	8,0	64
1287077	2254-0728	32,0	1,00	8,0	80
1424927	2254-0734	32,0	1,40	8,0	48
1345631	2254-0736	32,0	1,60	8,0	48
1289382	2254-0738	32,0	2,00	8,0	48
1220869	2254-0746	32,0	3,00	8,0	40
1177816	2254-0748	32,0	4,00	8,0	40
1425501	—	35,0	0,40	13,0	64
1425502	—	35,0	0,50	13,0	64
1345630	—	35,0	0,60	13,0	64
1416722	—	35,0	0,70	13,0	64
1416723	—	35,0	0,90	13,0	64
1337450	2254-0752	40,0	0,20	10,0	128
1256877	2254-0756	40,0	0,30	10,0	100
1220014	2254-0758	40,0	0,40	10,0	100
1173036	2254-0762	40,0	0,50	10,0	80
1174850	2254-0764	40,0	0,60	10,0	80
1240480	—	40,0	0,70	10,0	80
1174852	2254-0766	40,0	0,80	10,0	80
1326201	2254-0768	40,0	1,00	10,0	64
1173058	2254-0772	40,0	1,20	10,0	64
1177818	2254-0774	40,0	1,40	10,0	64
1326202	2254-0776	40,0	1,60	10,0	64
1182021	—	40,0	2,00	10,0	80
1173067	2254-0782	40,0	2,50	10,0	48
1174854	2254-0786	40,0	3,00	10,0	48
1174855	2254-0788	40,0	4,00	10,0	40
1177822	2254-0792	40,0	5,00	10,0	40
1174857	2254-0798	50,0	0,30	13,0	128
1220015	2254-0804	50,0	0,50	13,0	100
1345632	2254-0806	50,0	0,60	13,0	100
1177824	2254-0808	50,0	0,80	13,0	80
1182022	2254-0812	50,0	1,00	13,0	80
1173123	2254-0814	50,0	1,20	13,0	80
1173138	2254-0818	50,0	1,60	13,0	64
1337452	2254-0822	50,0	2,00	13,0	64
1173162	2254-0824	50,0	2,50	13,0	64
1173169	2254-0828	50,0	3,00	13,0	48

Артикул	Обозначение по ГОСТ	D, мм	B, мм	d, мм	Z, шт
1174862	2254-0832	50,0	4,00	13,0	48
1174864	2254-0834	50,0	5,00	13,0	48
1177830	2254-0836	50,0	6,00	13,0	40
1173213	2254-0842	63,0	0,30	16,0	128
1173216	2254-0844	63,0	0,40	16,0	128
1173230	2254-0846	63,0	0,50	16,0	128
1177831	2254-0848	63,0	0,60	16,0	100
1240482	—	63,0	0,70	16,0	100
1174866	2254-0852	63,0	0,80	16,0	100
1177833	—	63,0	0,90	16,0	100
1173268	2254-0854	63,0	1,00	16,0	100
1337454	2254-0856	63,0	1,20	16,0	80
1240484	—	63,0	1,30	16,0	80
1284766	2254-0858	63,0	1,40	16,0	80
1173319	2254-0862	63,0	1,60	16,0	80
1337455	2254-0864	63,0	2,00	16,0	80
1173359	2254-0866	63,0	2,50	16,0	64
1337457	2254-0872	63,0	3,00	16,0	64
1179911	2254-0874	63,0	4,00	16,0	64
1179912	2254-0876	63,0	5,00	16,0	48
1179913	2254-0878	63,0	6,00	16,0	48
1173433	2254-0886	80,0	0,50	22,0	128
1173436	2254-0888	80,0	0,60	22,0	128
1173441	2254-0892	80,0	0,80	22,0	128
1337458	2254-0894	80,0	1,00	22,0	100
1335560	2254-0896	80,0	1,20	22,0	100
1240486	—	80,0	1,30	22,0	100
1377917	2254-0898	80,0	1,40	22,0	100
1337460	2254-0902	80,0	1,60	22,0	100
1477497	2254-0904	80,0	2,00	22,0	80
1173532	2254-0906	80,0	2,50	22,0	80
1258985	—	80,0	3,50	22,0	64
1173570	2254-0914	80,0	4,00	22,0	64
1177835	2254-0916	80,0	5,00	22,0	64
1177836	2254-0918	80,0	6,00	22,0	64
1185631	2254-0924	100,0	0,60	22,0	160
1173587	2254-0926	100,0	0,80	22,0	128
1335561	2254-0928	100,0	1,00	22,0	128
1173601	2254-0932	100,0	1,20	27,0	128

Артикул	Обозначение по ГОСТ	D, мм	B, мм	d, мм	Z, шт
1289626	2254-0934	100,0	1,40	22,0	100
1182023	2254-0936	100,0	1,60	22,0	100
1182024	2254-0938	100,0	2,00	22,0	100
1173643	2254-0942	100,0	2,50	27,0	100
1182025	2254-0948	100,0	4,00	22,0	80
1179914	2254-0952	100,0	5,00	22,0	80
1179915	2254-0954	100,0	6,00	22,0	64
1174868	2254-0958	125,0	0,80	22,0	160
1174870	2254-0962	125,0	1,00	22,0	160
1177837	2254-0964	125,0	1,20	22,0	128
1337480	2254-0968	125,0	1,60	22,0	128
1284764	2254-0972	125,0	2,00	22,0	128
1178824	2254-0978	125,0	3,00	22,0	100
1182026	2254-0982	125,0	4,00	22,0	100
1177838	2254-0984	125,0	5,00	22,0	80
1177839	2254-0986	125,0	6,00	22,0	80
1337823	—	160,0	0,80	32,0	200
1174872	2254-0992	160,0	1,20	32,0	160
1227827	2254-0994	160,0	1,40	32,0	160
1174874	2254-0996	160,0	1,60	32,0	160
1174875	2254-0998	160,0	2,00	32,0	128
1174876	2254-1002	160,0	2,50	32,0	128

Артикул	Обозначение по ГОСТ	D, мм	B, мм	d, мм	Z, шт
1174877	2254-1006	160,0	3,00	32,0	128
1174878	2254-1008	160,0	4,00	32,0	100
1174879	2254-1012	160,0	5,00	32,0	100
1174880	2254-1014	160,0	6,00	32,0	100
1174882	2254-1024	200,0	1,60	32,0	160
1174884	2254-1026	200,0	2,00	32,0	160
1284765	2254-1028	200,0	2,50	32,0	160
1377338	2254-1032	200,0	2,80	32,0	160
1220870	2254-1034	200,0	3,00	32,0	128
1220871	2254-1036	200,0	4,00	32,0	132
1174888	2254-1038	200,0	5,00	32,0	128
1174889	2254-1042	200,0	6,00	32,0	100
1220872	2254-1046	250,0	2,00	32,0	200
1220873	2254-1048	250,0	2,50	32,0	160
1220877	2254-1056	250,0	4,00	32,0	160
1220880	2254-1058	250,0	5,00	32,0	128
1220885	2254-1064	315,0	2,50	40,0	200
1220887	2254-1068	315,0	3,00	40,0	200
1220889	2254-1072	315,0	4,00	40,0	160
1220891	2254-1074	315,0	5,00	40,0	160
1220893	2254-1076	315,0	6,00	40,0	160

Фрезы прорезные и отрезные из быстрорежущей стали со средним зубом

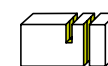

ГОСТ 2679-2014



P6M5



Средний зуб Тип 2

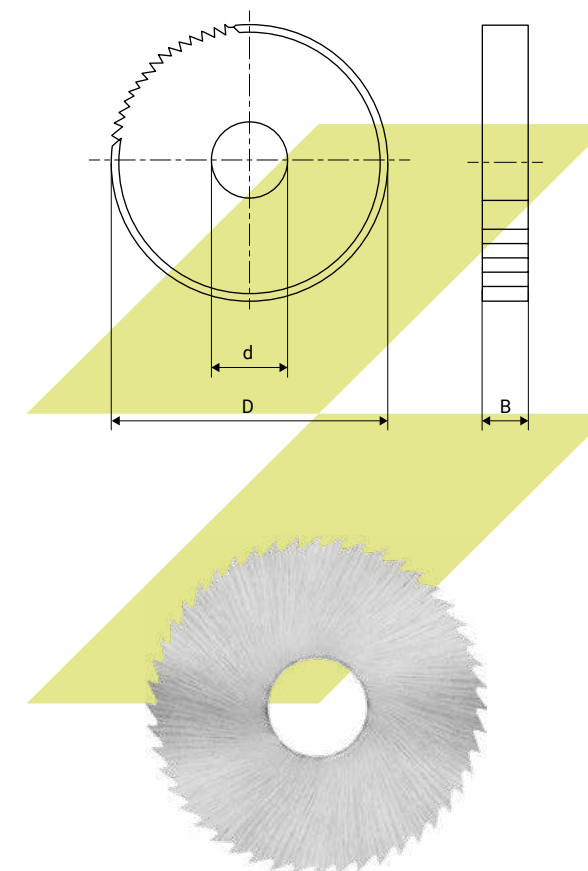

Артикул	Обозначение по ГОСТ	D, мм	B, мм	d, мм	Z, шт
1177812	2254-2002	32,0	0,30	8,0	40
1174839	2254-2004	32,0	0,40	8,0	40
1174840	2254-2006	32,0	0,50	8,0	40
1174842	2254-2008	32,0	0,60	8,0	32
1174844	2254-2011	32,0	0,80	8,0	32
1177815	—	32,0	0,90	8,0	32
1174845	2254-2013	32,0	1,00	8,0	32
1174846	2254-2015	32,0	1,20	8,0	24
1185091	2254-2017	32,0	1,60	8,0	24
1289383	2254-2019	32,0	2,00	8,0	24
1174847	2254-2026	40,0	0,30	10,0	48
1174848	2254-2028	40,0	0,40	10,0	48
1174849	2254-2031	40,0	0,50	10,0	40
1174851	2254-2033	40,0	0,60	10,0	40
1174853	2254-2035	40,0	0,80	10,0	40
1174948	2254-2037	40,0	1,00	10,0	32
1177817	2254-2039	40,0	1,20	10,0	32
1177819	2254-2042	40,0	1,60	10,0	32
1177820	2254-2044	40,0	2,00	10,0	24
1177821	2254-2046	40,0	2,50	10,0	24
1174949	2254-2048	40,0	3,00	10,0	24
1335940	—	40,0	3,50	10,0	20
1174856	2254-2051	40,0	4,00	10,0	20
1177823	—	40,0	5,00	10,0	20
1240481	—	50,0	0,25	13,0	64
1174858	2254-2106	50,0	0,30	13,0	64
1174859	2254-2108	50,0	0,40	13,0	48
1174860	2254-1142	50,0	0,50	13,0	48
1174861	2254-1144	50,0	0,60	13,0	48
1326572	—	50,0	0,60	13,0	40
1177825	2254-1146	50,0	0,80	13,0	40
1173113	2254-1148	50,0	1,00	13,0	40
1416668	—	50,0	1,10	16,0	48
1337451	2254-1152	50,0	1,20	13,0	40

Отрезные работы

Отрезные работы

Артикул	Обозначение по ГОСТ	D, мм	B, мм	d, мм	Z, шт
1416669	—	50,0	1,30	16,0	48
1173141	2254-1156	50,0	1,60	13,0	32
1416670	—	50,0	1,70	16,0	48
1173151	2254-1158	50,0	2,00	13,0	32
1173163	2254-1162	50,0	2,50	13,0	32
1173171	2254-1166	50,0	3,00	13,0	24
1174863	2254-2053	50,0	4,00	13,0	24
1174865	2254-2055	50,0	5,00	13,0	24
1254641	—	50,0	6,00	13,0	20
1173214	—	63,0	0,30	16,0	64
1173220	—	63,0	0,40	16,0	64
1173234	2254-1168	63,0	0,50	16,0	64
1177832	2254-1172	63,0	0,60	16,0	48
1240483	—	63,0	0,70	16,0	48
1174867	2254-1174	63,0	0,80	16,0	48
1177834	—	63,0	0,90	16,0	48
1337453	2254-1176	63,0	1,00	16,0	48
1173292	2254-1178	63,0	1,20	16,0	40
1240485	—	63,0	1,30	16,0	40
1284769	2254-1182	63,0	1,40	16,0	40
1173322	2254-1184	63,0	1,60	16,0	40
1337456	2254-1186	63,0	2,00	16,0	40
1173363	2254-1188	63,0	2,50	16,0	32
1173378	2254-1194	63,0	3,00	16,0	32
1173387	2254-2057	63,0	4,00	16,0	32
1173390	2254-2059	63,0	5,00	16,0	24
1173392	2254-2062	63,0	6,00	16,0	24
1173434	—	80,0	0,50	22,0	64
1173439	2254-1196	80,0	0,60	22,0	64
1173446	2254-1198	80,0	0,80	22,0	64
1335559	2254-1202	80,0	1,00	22,0	48
1337459	2254-1204	80,0	1,20	22,0	48
1240487	—	80,0	1,30	22,0	48
1173482	2254-1206	80,0	1,40	22,0	48
1337461	2254-1208	80,0	1,60	22,0	48
1337462	2254-1212	80,0	2,00	22,0	40
1173534	2254-1214	80,0	2,50	22,0	40
1173555	2254-1218	80,0	3,00	22,0	40
1173562	2254-1222	80,0	3,50	22,0	40

Артикул	Обозначение по ГОСТ	D, мм	B, мм	d, мм	Z, шт
1173577	—	80,0	5,00	22,0	24
1418040	2254-2064	80,0	5,00	22,0	32
1173580	—	80,0	6,00	22,0	24
1289627	2254-2066	80,0	6,00	22,0	32
1227826	2254-1226	100,0	0,60	22,0	64
1173589	2254-1228	100,0	0,80	22,0	64
1227792	2254-1232	100,0	1,00	22,0	64
1173603	—	100,0	1,20	27,0	64
1173621	—	100,0	1,60	27,0	64
1286968	2254-1242	100,0	2,00	22,0	48
1337464	2254-1244	100,0	2,50	22,0	48
1173655	2254-1246	100,0	2,80	22,0	48
1284768	2254-1248	100,0	3,00	22,0	40
1173672	2254-1252	100,0	3,50	27,0	40
1284767	2254-1254	100,0	4,00	22,0	40
1173682	2254-2068	100,0	5,00	22,0	40
1173685	2254-2071	100,0	6,00	22,0	32
1174869	—	125,0	0,80	22,0	80
1174871	2254-1258	125,0	1,00	22,0	80
1240488	2254-1262	125,0	1,20	22,0	64
1477501	—	125,0	1,60	27,0	64
1337465	2254-1268	125,0	2,00	22,0	64
1417070	2254-1272	125,0	2,50	22,0	48
1178825	2254-1276	125,0	3,00	22,0	48
1173743	2254-1278	125,0	3,50	27,0	48
1417642	2254-1282	125,0	4,00	22,0	48
1173757	2254-2073	125,0	5,00	22,0	40
1173760	2254-2075	125,0	6,00	22,0	40
1337824	—	160,0	0,80	32,0	100
1174873	2254-1286	160,0	1,20	32,0	80
1227828	2254-1288	160,0	1,40	32,0	80
1417643	2254-1292	160,0	1,60	32,0	80
1284387	—	160,0	1,80	32,0	80
1260501	2254-1294	160,0	2,00	32,0	64
1173797	2254-1296	160,0	2,50	32,0	64
1173807	2254-1302	160,0	3,00	32,0	64
1177841	2254-1304	160,0	3,50	32,0	64
1177842	2254-1306	160,0	4,00	32,0	48
1417646	—	160,0	4,00	32,0	64

Артикул	Обозначение по ГОСТ	D, мм	B, мм	d, мм	Z, шт
1258074	2254-1308	160,0	4,50	32,0	48
1174836	2254-1312	160,0	5,00	32,0	48
1289474	2254-1732	160,0	5,50	32,0	48
1174881	2254-1314	160,0	6,00	32,0	48
1178826	—	200,0	1,20	32,0	80
1174883	2254-1322	200,0	1,60	32,0	80
1174885	2254-1324	200,0	2,00	32,0	80
1174886	2254-1326	200,0	2,50	32,0	80
1377339	2254-1328	200,0	2,80	32,0	80
1173863	2254-1332	200,0	3,00	32,0	64
1174887	2254-1334	200,0	3,50	32,0	64
1173882	2254-1336	200,0	4,00	32,0	64
1178827	2254-1338	200,0	4,50	32,0	64
1173895	2254-1342	200,0	5,00	32,0	64
1178828	2254-1734	200,0	5,50	32,0	64
1173902	2254-1344	200,0	6,00	32,0	48

Артикул	Обозначение по ГОСТ	D, мм	B, мм	d, мм	Z, шт
1182028	—	250,0	1,00	32,0	100
1173906	2254-1348	250,0	2,00	32,0	100
1220874	2254-1352	250,0	2,50	32,0	80
1173912	2254-1356	250,0	3,00	32,0	80
1182029	2254-1358	250,0	3,50	32,0	80
1173914	2254-1362	250,0	4,00	32,0	80
1173920	2254-1366	250,0	5,00	32,0	64
1220882	2254-1736	250,0	5,50	32,0	64
1173925	2254-1368	250,0	6,00	32,0	64
1178829	2254-1372	315,0	2,50	40,0	100
1178830	2254-1376	315,0	3,00	40,0	100
1330850	2254-1378	315,0	3,50	40,0	100
1178831	2254-1382	315,0	4,00	40,0	80
1173935	2254-1386	315,0	5,00	40,0	80
1330849	2254-1738	315,0	5,50	40,0	80
1174952	2254-1388	315,0	6,00	40,0	80

Фрезы прорезные и отрезные из быстрорежущей стали с крупным зубом

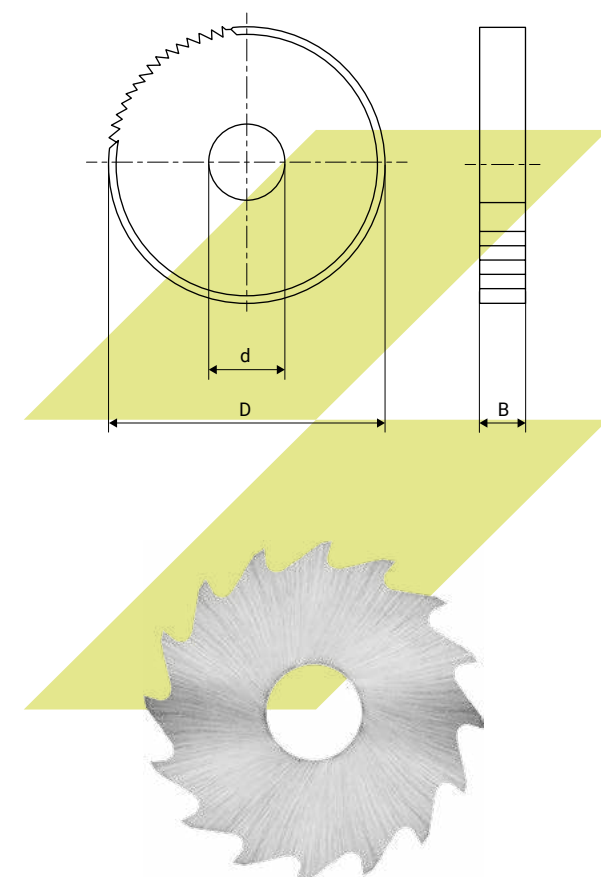
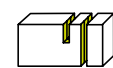

Артикул	Обозначение по ГОСТ	D, мм	B, мм	d, мм	Z, шт
1326203	2254-1422	50,0	1,00	13,0	20
1326204	2254-1424	50,0	1,20	13,0	20
1326205	2254-1426	50,0	1,60	13,0	16
1326206	2254-1428	50,0	2,00	13,0	16
1173167	2254-1432	50,0	2,50	13,0	24
1477493	2254-1434	63,0	1,00	16,0	24
1531140	2254-1438	63,0	1,60	16,0	20
1236908	2254-1444	63,0	2,50	16,0	16
1256878	2254-1446	63,0	3,00	16,0	16
1284774	2254-1594	80,0	1,00	22,0	20
1477495	2254-1452	80,0	1,20	22,0	24
1477496	2254-1452	80,0	1,20	22,0	20
1260486	2254-1602	80,0	2,00	22,0	16
1337463	2254-1462	80,0	3,00	22,0	20
1284772	2254-1608	100,0	1,00	22,0	22
1284770	2254-1612	100,0	1,20	22,0	20
1284771	2254-1614	100,0	1,60	22,0	20
1260487	2254-1616	100,0	2,00	22,0	18
1477498	2254-1474	100,0	2,50	22,0	24
1174831	2254-1476	100,0	3,00	22,0	20
1174832	2254-1254	100,0	4,00	22,0	20
1240489	2254-1478	125,0	1,60	22,0	32
1276309	2254-1482	125,0	2,00	22,0	32
1260488	2254-1628	125,0	2,50	22,0	20
1276310	2254-1484	125,0	2,50	22,0	24
1284773	2254-1632	125,0	3,00	22,0	18
1276311	2254-1486	125,0	3,00	22,0	24
1378503	—	125,0	4,00	27,0	128
1418338	—	125,0	4,00	27,0	24
1257819	—	125,0	4,50	22,0	20
1257820	—	125,0	5,00	22,0	20
1284607	2254-1638	160,0	1,60	32,0	26
1376259	—	160,0	1,60	32,0	32
1284608	2254-1494	160,0	1,60	32,0	40

Артикул	Обозначение по ГОСТ	D, мм	B, мм	d, мм	Z, шт
1174833	2254-1496	160,0	2,00	32,0	32
1177840	2254-1498	160,0	2,50	32,0	32
1260489	2254-1646	160,0	3,00	32,0	20
1174834	2254-1502	160,0	3,00	32,0	32
1276312	2254-1504	160,0	3,50	32,0	32
1174835	2254-1506	160,0	4,00	32,0	24
1177843	2254-1508	160,0	4,50	32,0	24
1174837	2254-1512	200,0	2,00	32,0	40
1260490	2254-1658	200,0	2,50	32,0	26
1177844	2254-1514	200,0	2,50	32,0	40
1260491	2254-1662	200,0	3,00	32,0	22
1174838	2254-1516	200,0	3,00	32,0	32
1269766	2254-1664	200,0	3,50	32,0	22
1269767	2254-1518	200,0	3,50	32,0	32
1276316	2254-1334	200,0	3,50	32,0	32
1220834	2254-1552	200,0	4,00	32,0	32

Артикул	Обозначение по ГОСТ	D, мм	B, мм	d, мм	Z, шт
1177845	2254-1524	200,0	4,50	32,0	32
1220835	2254-1526	200,0	5,00	32,0	32
1276318	2254-1528	250,0	2,50	32,0	40
1220875	2254-1532	250,0	3,00	32,0	40
1220876	2254-1534	250,0	3,50	32,0	40
1220878	2254-1536	250,0	4,00	32,0	40
1220879	2254-1538	250,0	4,50	32,0	40
1220881	2254-1542	250,0	5,00	32,0	32
1220883	2254-1542	250,0	5,50	32,0	32
1220884	2254-1544	250,0	6,00	32,0	32
1220886	2254-1546	315,0	2,50	40,0	48
1220888	2254-1548	315,0	3,00	40,0	48
1220890	2254-1552	315,0	4,00	40,0	40
1220892	2254-1554	315,0	5,00	40,0	40
1220894	2254-1556	315,0	6,00	40,0	40

Фрезы отрезные из быстрорежущей стали для обработки легких сплавов с крупным зубом

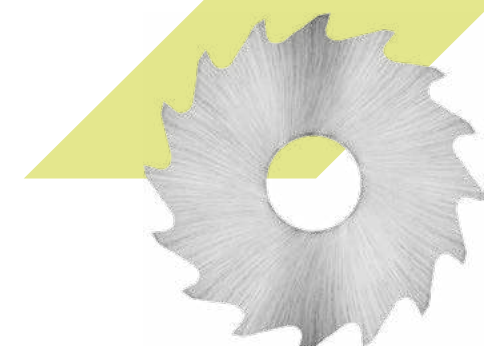
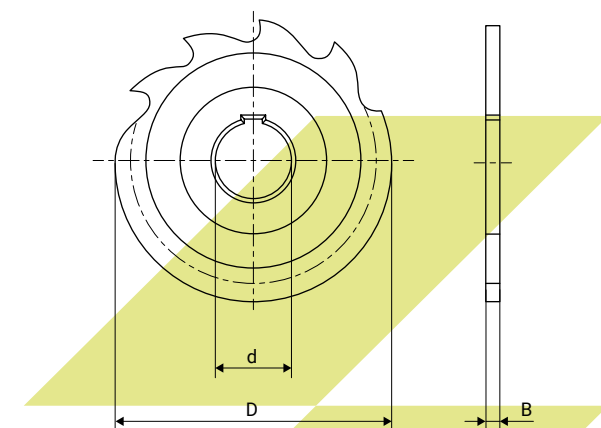
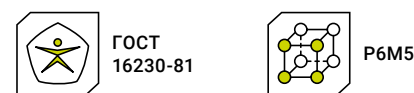
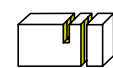

Артикул	Обозначение по ГОСТ	D, мм	B, мм	d, мм	Z, шт
1416899	2254-0502	63,0	1,20	16,0	16
1416900	2254-0503	63,0	1,60	16,0	16
1416901	2254-0504	63,0	2,00	16,0	14
1416902	2254-0505	63,0	2,50	16,0	14
1416903	2254-0506	80,0	1,20	22,0	16
1416904	2254-0508	80,0	1,60	22,0	16
1416905	2254-0509	80,0	2,00	22,0	14
1416906	2254-0510	80,0	2,50	22,0	14
1416907	2254-0511	80,0	3,00	22,0	12
1416908	2254-0513	100,0	1,20	22,0	18
1416909	2254-0514	100,0	1,60	22,0	18
1416910	2254-0515	100,0	2,00	22,0	16
1416911	2254-0516	100,0	2,50	22,0	16
1416912	2254-0517	100,0	3,00	22,0	12
1416913	2254-0518	125,0	1,60	27,0	16
1416914	2254-0519	125,0	2,00	27,0	14
1416915	2254-0520	125,0	2,50	27,0	14
1416916	2254-0521	125,0	3,00	27,0	12
1416917	2254-0522	125,0	4,00	27,0	12
1416918	2254-0523	160,0	2,00	32,0	14
1416919	2254-0524	160,0	2,50	32,0	14
1416857	2254-0525	160,0	3,00	32,0	12
1416920	2254-0526	160,0	4,00	32,0	12
1416921	2254-0527	200,0	3,00	32,0	18
1416922	2254-0528	200,0	4,00	32,0	18
1416923	2254-0529	200,0	5,00	32,0	16

Фрезы отрезные из быстрорежущей стали с мелким зубом

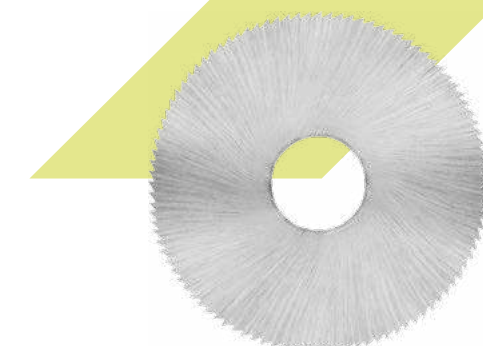
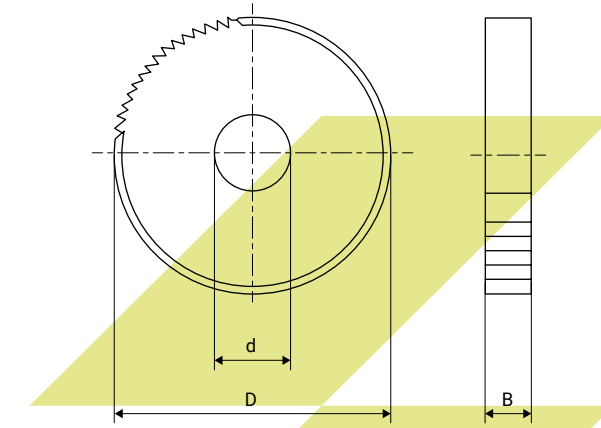
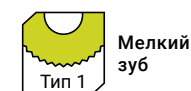
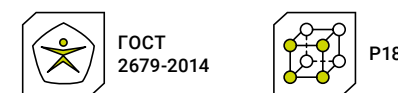
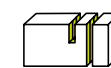

Артикул	Обозначение по ГОСТ	D, мм	B, мм	d, мм	Z, шт
1805421	2254-0714	32,0	0,25	8,0	100
1805698	2254-0722	32,0	0,50	8,0	80
1805699	2254-0724	32,0	0,60	8,0	64
1805828	2254-0726	32,0	0,80	8,0	64
1805829	2254-0728	32,0	1,00	8,0	64
1805422	2254-0752	40,0	0,20	10,0	128
1805423	2254-0754	40,0	0,25	10,0	100
1805424	2254-0756	40,0	0,30	10,0	100
1805425	2254-0758	40,0	0,40	10,0	100
1805426	2254-0762	40,0	0,50	10,0	80
1805427	2254-0764	40,0	0,60	10,0	80
1805703	2254-0766	40,0	0,80	10,0	80
1805830	2254-0768	40,0	1,00	10,0	64
1805831	2254-0782	40,0	2,50	10,0	48
1805832	2254-0796	50,0	0,25	13,0	128
1805834	2254-0798	50,0	0,30	13,0	128
1805835	2254-0802	50,0	0,40	13,0	100
1805428	2254-0804	50,0	0,50	13,0	100
1805430	2254-0806	50,0	0,60	13,0	100
1805704	2254-0808	50,0	0,80	13,0	80
1805836	2254-0812	50,0	1,00	13,0	80
1805094	2254-0844	63,0	0,40	16,0	128
1805095	2254-0846	63,0	0,50	16,0	128
1805096	2254-0848	63,0	0,60	16,0	100
1805097	2254-0852	63,0	0,80	16,0	100
1805098	2254-0854	63,0	1,00	16,0	100
1805099	2254-0856	63,0	1,20	16,0	80
1805100	2254-0858	63,0	1,40	16,0	80
1805101	2254-0862	63,0	1,60	16,0	80
1805102	2254-0864	63,0	2,00	16,0	80
1805103	2254-0866	63,0	2,50	16,0	64
1805104	2254-0872	63,0	3,00	16,0	64
1805105	2254-0874	63,0	4,00	16,0	64
1805106	2254-0876	63,0	5,00	16,0	48

Артикул	Обозначение по ГОСТ	D, мм	B, мм	d, мм	Z, шт
1805107	2254-0878	63,0	6,00	16,0	48
1805435	2254-0894	80,0	1,00	22,0	100
1805840	2254-0902	80,0	1,60	22,0	100
1805842	2254-0904	80,0	2,00	22,0	80
1805437	2254-0906	80,0	2,50	22,0	80
1805844	2254-0912	80,0	3,00	22,0	80
1805149	2254-0928	100,0	1,00	22,0	128
1805150	—	100,0	1,20	27,0	128
1805846	—	100,0	1,60	27,0	100
1805440	—	100,0	2,50	27,0	100
1805441	—	100,0	3,00	27,0	80
1805151	2254-0964	125,0	1,20	22,0	128
1805847	—	125,0	1,60	27,0	128

Артикул	Обозначение по ГОСТ	D, мм	B, мм	d, мм	Z, шт
1805719	—	125,0	2,00	27,0	128
1805851	—	125,0	2,50	27,0	100
1805852	—	125,0	3,00	27,0	100
1805854	—	125,0	4,00	27,0	100
1805152	2254-0996	160,0	1,60	32,0	160
1805153	2254-0998	160,0	2,00	32,0	128
1805154	2254-1002	160,0	2,50	32,0	128
1805155	2254-1026	200,0	2,00	32,0	160
1805157	2254-1028	200,0	2,50	32,0	160
1805158	2254-1034	200,0	3,00	32,0	128
1805160	2254-1036	200,0	4,00	32,0	128
1805162	2254-1038	200,0	5,00	32,0	128

Фрезы отрезные из быстрорежущей стали со средним зубом

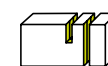

ГОСТ 2679-2014

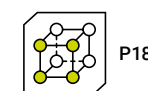

P18



Средний зуб
Тип 2

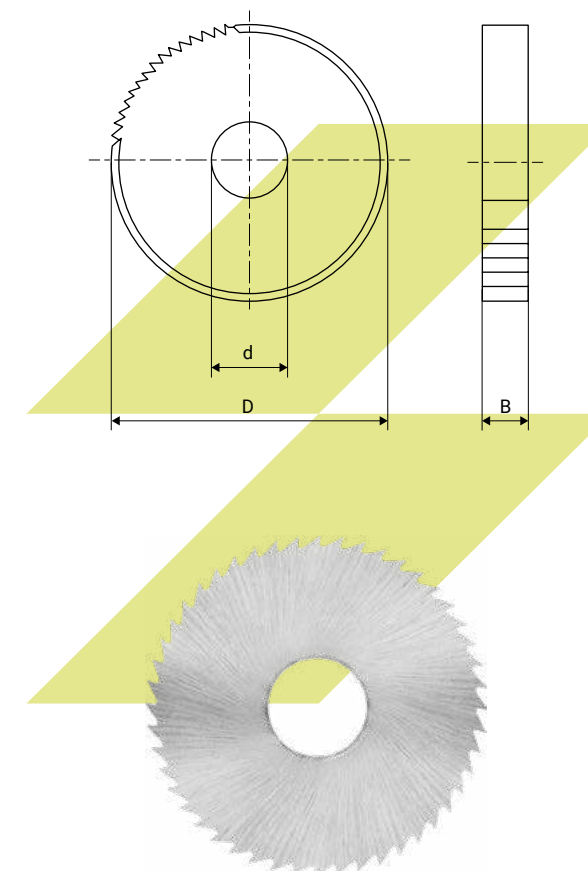

Артикул	Обозначение по ГОСТ	D, мм	B, мм	d, мм	Z, шт
1805429	2254-1142	50,0	0,50	13,0	48
1805431	2254-1168	63,0	0,50	16,0	64
1805837	2254-1172	63,0	0,60	16,0	48
1805432	2254-1174	63,0	0,80	16,0	48
1805433	2254-1176	63,0	1,00	16,0	48
1805434	2254-1178	63,0	1,20	16,0	40
1805707	2254-1184	63,0	1,60	16,0	40
1805838	2254-1186	63,0	2,00	16,0	40
1805436	2254-1202	80,0	1,00	22,0	48
1805839	2254-1204	80,0	1,20	22,0	48
1805841	2254-1208	80,0	1,60	22,0	48
1805843	2254-1212	80,0	2,00	22,0	40
1805708	2254-1214	80,0	2,50	22,0	40
1805438	2254-1218	80,0	3,00	22,0	40
1805845	—	100,0	1,20	27,0	64
1805439	—	100,0	1,60	27,0	48
1805264	2254-1242	100,0	2,00	22,0	48
1805714	—	100,0	3,00	27,0	40
1805717	—	100,0	4,00	27,0	40
1853059	—	125,0	1,20	27,0	64
1805848	—	125,0	1,60	27,0	64
1805720	—	125,0	2,00	27,0	64
1853060	—	125,0	2,00	27,0	80
1805722	—	125,0	2,50	27,0	48
1805723	—	125,0	3,00	27,0	48
1805853	—	125,0	3,50	27,0	48
1805724	—	125,0	4,00	27,0	48
1805727	2254-1292	160,0	1,60	32,0	80
1805265	2254-1294	160,0	2,00	32,0	64
1805856	2254-1296	160,0	2,50	32,0	64
1805728	2254-1302	160,0	3,00	32,0	64
1805729	2254-1304	160,0	3,50	32,0	64
1805731	2254-1306	160,0	4,00	32,0	48
1805156	2254-1324	200,0	2,00	32,0	80

Отрезные работы

Отрезные работы

Артикул	Обозначение по ГОСТ	D, мм	B, мм	d, мм	Z, шт
1805735	2254-1326	200,0	2,50	32,0	80
1805159	2254-1332	200,0	3,00	32,0	64
1805736	2254-1334	200,0	3,50	32,0	64
1805161	2254-1336	200,0	4,00	32,0	64
1805737	2254-1342	200,0	5,00	32,0	64

Фрезы отрезные из быстрорежущей стали с крупным зубом

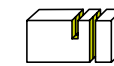

ГОСТ 2679-2014

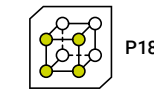

P18



Крупный зуб
Тип 3

Артикул	Обозначение по ГОСТ	D, мм	B, мм	d, мм	Z, шт
1805849	—	125,0	1,6	27,0	32
1805850	—	125,0	2,0	27,0	32
1805855	—	125,0	4,0	27,0	24

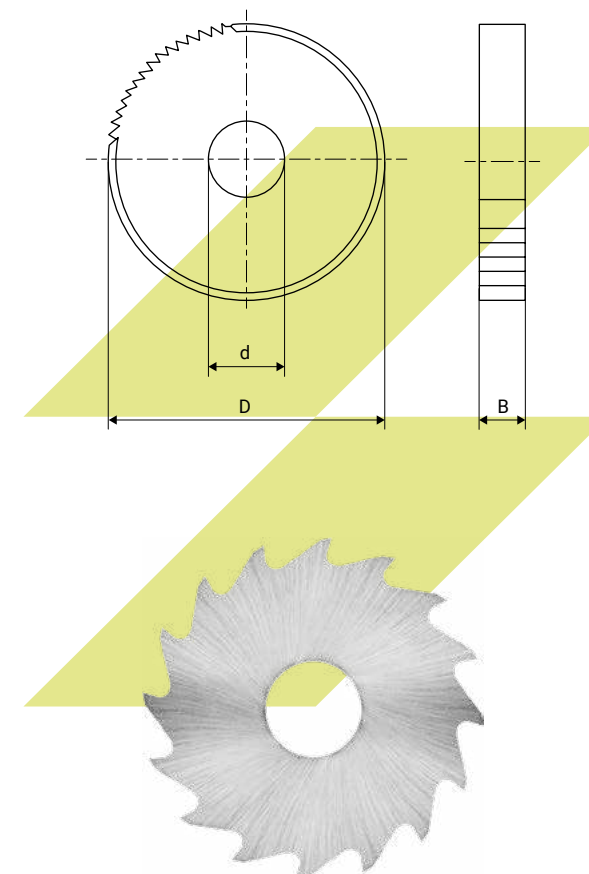

Фрезы прорезные и отрезные из твердого сплава с мелким и средним зубом

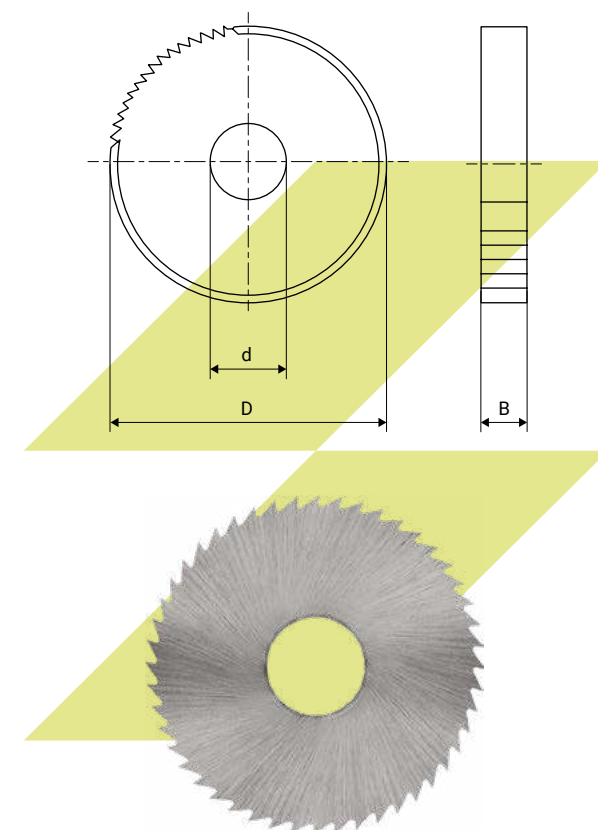
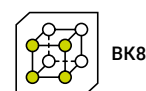

Артикул	Стандарт	D, мм	B, мм	d, мм	Z, шт
1785106	DIN 1837	25,0	0,30	8,0	80
1785107	DIN 1837	25,0	0,40	8,0	64
1785108	DIN 1837	25,0	0,60	8,0	64
1785109	DIN 1837	25,0	0,80	8,0	48
1785110	DIN 1837	30,0	0,30	8,0	80
1785111	DIN 1838	30,0	0,30	8,0	40
1785112	DIN 1837	30,0	0,50	8,0	80
1785113	DIN 1838	30,0	0,50	8,0	40
1785114	DIN 1837	30,0	0,60	8,0	64
1785115	DIN 1838	30,0	0,60	8,0	32
1785116	DIN 1837	30,0	0,80	8,0	64
1785117	DIN 1838	30,0	0,80	8,0	32
1785118	DIN 1837	30,0	1,00	8,0	64
1785119	DIN 1838	30,0	1,00	8,0	32
1785120	DIN 1837	30,0	1,20	8,0	48
1785121	DIN 1838	30,0	1,20	8,0	24
1785122	—	35,0	0,50	13,0	64
1785123	—	35,0	0,60	13,0	64
1785124	—	35,0	0,70	13,0	64
1785125	—	35,0	0,90	13,0	64
1785126	DIN 1837	40,0	0,30	10,0	100
1785127	DIN 1838	40,0	0,30	10,0	48
1785128	DIN 1837	40,0	0,40	10,0	100
1785129	DIN 1838	40,0	0,40	10,0	48
1785130	DIN 1837	40,0	0,50	10,0	80
1785131	DIN 1838	40,0	0,50	10,0	40
1785132	DIN 1837	40,0	0,60	10,0	80
1785133	DIN 1838	40,0	0,60	10,0	40
1785134	DIN 1837	40,0	0,80	10,0	80
1785135	DIN 1838	40,0	0,80	10,0	40
1785136	DIN 1837	40,0	1,00	10,0	64
1785137	DIN 1838	40,0	1,00	10,0	32
1785138	DIN 1837	40,0	1,20	10,0	64
1785139	DIN 1838	40,0	1,20	10,0	32

Артикул	Стандарт	D, мм	B, мм	d, мм	Z, шт
1785140	DIN 1837	40,0	1,40	10,0	64
1785141	DIN 1838	40,0	1,40	10,0	32
1785142	DIN 1837	40,0	1,60	10,0	64
1785143	DIN 1838	40,0	1,60	10,0	32
1785144	DIN 1837	40,0	2,00	10,0	48
1785145	DIN 1838	40,0	2,00	10,0	24
1785146	DIN 1837	40,0	2,50	10,0	48
1785147	DIN 1838	40,0	2,50	10,0	24
1785148	DIN 1837	40,0	3,00	10,0	48
1785149	DIN 1838	40,0	3,00	10,0	24
1785150	DIN 1837	40,0	4,00	10,0	40
1785151	DIN 1838	40,0	4,00	10,0	20
1785152	DIN 1837	40,0	5,00	10,0	40
1785153	DIN 1838	40,0	5,00	10,0	20
1785154	DIN 1837	40,0	6,00	10,0	40
1785155	DIN 1837	50,0	0,30	13,0	128
1785156	DIN 1838	50,0	0,30	13,0	64
1785157	DIN 1837	50,0	0,40	13,0	100
1785158	DIN 1838	50,0	0,40	13,0	48
1785159	DIN 1837	50,0	0,50	13,0	100
1785160	DIN 1838	50,0	0,50	13,0	48
1785161	DIN 1837	50,0	0,60	13,0	100
1785162	DIN 1838	50,0	0,60	13,0	48
1785163	DIN 1837	50,0	0,80	13,0	80
1785164	DIN 1838	50,0	0,80	13,0	40
1785165	DIN 1837	50,0	1,00	13,0	80
1785166	DIN 1838	50,0	1,00	13,0	40
1785167	—	50,0	1,10	16,0	48
1785168	DIN 1837	50,0	1,20	13,0	80
1785169	DIN 1838	50,0	1,20	13,0	40
1785170	—	50,0	1,30	16,0	48
1785171	DIN 1837	50,0	1,40	13,0	80
1785172	DIN 1838	50,0	1,40	13,0	40
1785173	DIN 1837	50,0	1,60	13,0	64
1785174	DIN 1838	50,0	1,60	13,0	32
1785175	—	50,0	1,70	16,0	48
1785176	DIN 1837	50,0	2,00	13,0	64
1785177	DIN 1838	50,0	2,00	13,0	32
1785178	DIN 1837	50,0	2,50	13,0	64

Артикул	Стандарт	D, мм	B, мм	d, мм	Z, шт
1785179	DIN 1838	50,0	2,50	13,0	32
1785180	DIN 1837	50,0	3,00	13,0	48
1785181	DIN 1838	50,0	3,00	13,0	24
1785182	DIN 1837	50,0	4,00	13,0	48
1785183	DIN 1838	50,0	4,00	13,0	24
1785184	DIN 1837	50,0	5,00	13,0	48
1785185	DIN 1838	50,0	5,00	13,0	24
1785186	DIN 1837	50,0	6,00	13,0	40
1785187	DIN 1837	63,0	0,30	16,0	128
1785188	DIN 1838	63,0	0,30	16,0	64
1785189	DIN 1837	63,0	0,40	16,0	128
1785190	DIN 1838	63,0	0,40	16,0	64
1785191	DIN 1837	63,0	0,50	16,0	128
1785192	DIN 1838	63,0	0,50	16,0	64
1785193	DIN 1837	63,0	0,60	16,0	100
1785194	DIN 1838	63,0	0,60	16,0	48
1785195	DIN 1837	63,0	0,80	16,0	100
1785196	DIN 1838	63,0	0,80	16,0	48
1785197	DIN 1837	63,0	1,00	16,0	100
1785198	DIN 1838	63,0	1,00	16,0	48
1785199	DIN 1837	63,0	1,20	16,0	80
1785200	DIN 1838	63,0	1,20	16,0	40
1785201	DIN 1837	63,0	1,40	16,0	80
1785202	DIN 1838	63,0	1,40	16,0	40
1785203	DIN 1837	63,0	1,60	16,0	80
1785204	DIN 1838	63,0	1,60	16,0	40
1785205	DIN 1837	63,0	2,00	16,0	80
1785206	DIN 1838	63,0	2,00	16,0	40
1785207	DIN 1837	63,0	2,50	16,0	64
1785208	DIN 1838	63,0	2,50	16,0	32
1785209	DIN 1837	63,0	3,00	16,0	64
1785210	DIN 1838	63,0	3,00	16,0	32
1785211	DIN 1837	63,0	4,00	16,0	64
1785212	DIN 1838	63,0	4,00	16,0	32
1785213	DIN 1837	63,0	5,00	16,0	48
1785214	DIN 1838	63,0	5,00	16,0	24
1785215	DIN 1837	63,0	6,00	16,0	48
1785216	DIN 1838	63,0	6,00	16,0	24
1785217	DIN 1837	80,0	0,50	22,0	128

Артикул	Стандарт	D, мм	B, мм	d, мм	Z, шт
1785218	DIN 1838	80,0	0,50	22,0	64
1785219	DIN 1837	80,0	0,60	22,0	128
1785220	DIN 1838	80,0	0,60	22,0	64
1785221	DIN 1837	80,0	0,80	22,0	128
1785222	DIN 1838	80,0	0,80	22,0	64
1785223	DIN 1837	80,0	1,00	22,0	100
1785224	DIN 1838	80,0	1,00	22,0	48
1785225	DIN 1837	80,0	1,20	22,0	100
1785226	DIN 1838	80,0	1,20	22,0	48
1785227	DIN 1837	80,0	1,40	22,0	100
1785228	DIN 1838	80,0	1,40	22,0	48
1785229	DIN 1837	80,0	1,60	22,0	100
1785230	DIN 1838	80,0	1,60	22,0	48

Артикул	Стандарт	D, мм	B, мм	d, мм	Z, шт
1785231	DIN 1837	80,0	2,00	22,0	80
1785232	DIN 1838	80,0	2,00	22,0	40
1785233	DIN 1837	80,0	2,50	22,0	80
1785234	DIN 1838	80,0	2,50	22,0	40
1785235	DIN 1837	80,0	3,00	22,0	80
1785236	DIN 1838	80,0	3,00	22,0	40
1785237	DIN 1838	80,0	3,50	22,0	40
1785238	DIN 1837	80,0	4,00	22,0	64
1785239	DIN 1838	80,0	4,00	22,0	32
1785240	DIN 1837	80,0	5,00	22,0	64
1785241	DIN 1838	80,0	5,00	22,0	32
1785242	DIN 1837	80,0	6,00	22,0	64
1785243	DIN 1838	80,0	6,00	22,0	32

Пилы ленточные

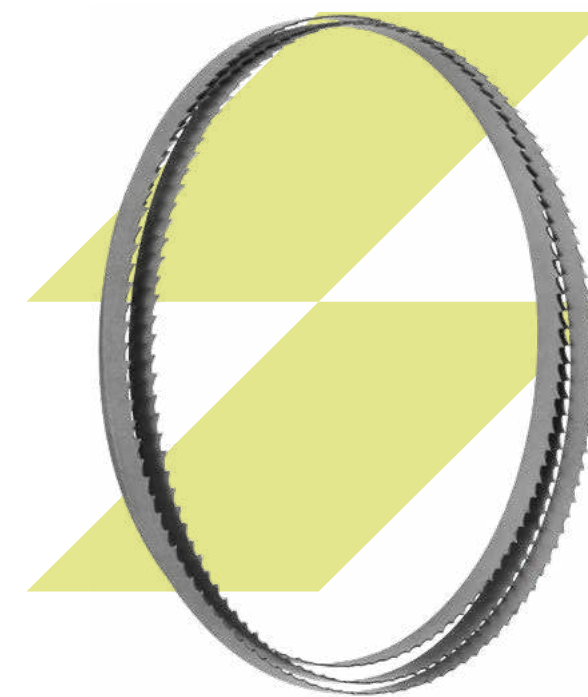
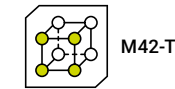



Артикул	P, мм	h × b, мм	L, мм
1784910	6–10	13 × 0,65	3460
1805447	10–14	13 × 0,65	1640
1806098	10–14	13 × 0,65	3260
1806099	10–14	13 × 0,65	3350
1806282	10–14	13 × 0,65	3370
1805889	10–14	13 × 0,65	9380
1788605	3–4	20 × 0,9	2362
1806292	4–6	20 × 0,9	2085
1788884	4–6	20 × 0,9	2360
1785131	5–8	20 × 0,9	2070
1785121	5–8	20 × 0,9	2362
1806293	6–10	20 × 0,9	2085
1806029	8–12	20 × 0,9	2360
1785086	10–14	20 × 0,9	2360
1805294	10–14	20 × 0,9	2362
1785034	10–14	20 × 0,9	5780
1806030	10–14	20 × 0,9	7220
1788871	2–3	27 × 0,9	2700
1805210	2–3	27 × 0,9	2880
1784958	2–3	27 × 0,9	3025
1806031	2–3	27 × 0,9	3215
1785039	2–3	27 × 0,9	3370
1772390	2–3	27 × 0,9	4070
1788948	2–3	27 × 0,9	6000
1772219	3–4	27 × 0,9	2550
1788872	3–4	27 × 0,9	2700
1805211	3–4	27 × 0,9	2710
1773937	3–4	27 × 0,9	2725
1785014	3–4	27 × 0,9	2740
1772220	3–4	27 × 0,9	2980
1784959	3–4	27 × 0,9	3025
1785015	3–4	27 × 0,9	3035
1785023	3–4	27 × 0,9	3200
1785125	3–4	27 × 0,9	3300

Отрезные работы

Отрезные работы

Артикул		P, мм	h × b, мм	L, мм
1788706	●	3-4	27 × 0,9	3500
1805679	●	3-4	27 × 0,9	3505
1774421	●	3-4	27 × 0,9	3660
1764163	●	3-4	27 × 0,9	3700
1774308	●	3-4	27 × 0,9	3850
1785007	●	3-4	27 × 0,9	4013
1806100	●	3-4	27 × 0,9	5500
1788707	●	3-4	27 × 0,9	5540
1788708	●	3-4	27 × 0,9	6500
1785162	●	4-6	27 × 0,9	2450
1788873	●	4-6	27 × 0,9	2700
1805212	●	4-6	27 × 0,9	2710
1785016	●	4-6	27 × 0,9	2740
1805213	●	4-6	27 × 0,9	2880
1806051	●	4-6	27 × 0,9	2910
1784960	●	4-6	27 × 0,9	3025
1785017	●	4-6	27 × 0,9	3035
1806114	●	4-6	27 × 0,9	3110
1805084	●	4-6	27 × 0,9	3180
1789046	●	4-6	27 × 0,9	3200
1806032	●	4-6	27 × 0,9	3215
1805083	●	4-6	27 × 0,9	3300
1788606	●	4-6	27 × 0,9	3320
1805680	●	4-6	27 × 0,9	3505
1805681	●	4-6	27 × 0,9	3660
1784983	●	4-6	27 × 0,9	5650
1805337	●	5-8	27 × 0,9	2460
1806129	●	5-8	27 × 0,9	2600
1784961	●	5-8	27 × 0,9	2650
1773888	●	5-8	27 × 0,9	2700
1805214	●	5-8	27 × 0,9	2710
1788745	●	5-8	27 × 0,9	2765
1774031	●	5-8	27 × 0,9	2910
1772470	●	5-8	27 × 0,9	3000
1784962	●	5-8	27 × 0,9	3025
1784964	●	5-8	27 × 0,9	3100
1773889	●	5-8	27 × 0,9	3160
1772663	●	5-8	27 × 0,9	3200
1773946	●	5-8	27 × 0,9	3215

Артикул		P, мм	h × b, мм	L, мм
1789047	●	5-8	27 × 0,9	3280
1784949	●	5-8	27 × 0,9	3300
1785040	●	5-8	27 × 0,9	3370
1784563	●	5-8	27 × 0,9	3660
1788746	●	5-8	27 × 0,9	4160
1774056	●	5-8	27 × 0,9	5341
1788975	●	6-10	27 × 0,9	2450
1788793	●	6-10	27 × 0,9	2655
1772577	●	6-10	27 × 0,9	2720
1805215	●	6-10	27 × 0,9	2880
1784963	●	6-10	27 × 0,9	3025
1784965	●	6-10	27 × 0,9	3100
1788656	●	6-10	27 × 0,9	3110
1788688	●	6-10	27 × 0,9	3215
1784950	●	6-10	27 × 0,9	3300
1784493	●	6-10	27 × 0,9	3370
1788863	●	6-10	27 × 0,9	3420
1788747	●	8-12	27 × 0,9	2455
1788778	●	8-12	27 × 0,9	2500
1789048	●	8-12	27 × 0,9	2550
1784667	●	8-12	27 × 0,9	2700
1806205	●	8-12	27 × 0,9	2710
1788864	●	8-12	27 × 0,9	2940
1789049	●	8-12	27 × 0,9	2980
1805196	●	8-12	27 × 0,9	3365
1788865	●	8-12	27 × 0,9	3420
1805762	●	10-14	27 × 0,9	2465
1784668	●	10-14	27 × 0,9	2700
1805216	●	10-14	27 × 0,9	2710
1805217	●	10-14	27 × 0,9	2880
1784947	●	10-14	27 × 0,9	3035
1784948	●	10-14	27 × 0,9	3300
1788794	●	4-6	27 × 0,9	2825
1788795	●	4-6	27 × 0,9	2950
1788796	●	5-8	27 × 0,9	2825
1788797	●	5-8	27 × 0,9	2950
1806101	●	2-3	34 × 1,1	3660
1788798	●	2-3	34 × 1,1	3920
1805694	●	2-3	34 × 1,1	4400

Артикул		P, мм	h × b, мм	L, мм
1788832	●	2-3	34 × 1,1	4520
1805511	●	2-3	34 × 1,1	4530
1805404	●	2-3	34 × 1,1	4780
1806102	●	3-4	34 × 1,1	3660
1788799	●	3-4	34 × 1,1	3920
1785163	●	3-4	34 × 1,1	4100
1772224	●	3-4	34 × 1,1	4115
1806083	●	3-4	34 × 1,1	4180
1788905	●	3-4	34 × 1,1	4240
1784510	●	3-4	34 × 1,1	4242
1805695	●	3-4	34 × 1,1	4400
1788625	●	3-4	34 × 1,1	4430
1788833	●	3-4	34 × 1,1	4520
1805512	●	3-4	34 × 1,1	4530
1785136	●	3-4	34 × 1,1	4600
1806267	●	3-4	34 × 1,1	4800
1806144	●	3-4	34 × 1,1	4950
1805394	●	3-4	34 × 1,1	5090
1784657	●	3-4	34 × 1,1	5450
1788709	●	3-4	34 × 1,1	5540
1788710	●	3-4	34 × 1,1	6500
1788800	●	4-6	34 × 1,1	3920
1806103	●	4-6	34 × 1,1	4115
1806211	●	4-6	34 × 1,1	4120
1806084	●	4-6	34 × 1,1	4180
1806104	●	4-6	34 × 1,1	4242
1788866	●	4-6	34 × 1,1	4300
1774447	●	4-6	34 × 1,1	4640
1784998	●	4-6	34 × 1,1	4900
1806145	●	4-6	34 × 1,1	4950
1785044	●	4-6	34 × 1,1	5000

Артикул		P, мм	h × b, мм	L, мм
1784542	●	4-6	34 × 1,1	5200
1788801	●	5-8	34 × 1,1	3920
1806085	●	5-8	34 × 1,1	4180
1785041	●	6-10	34 × 1,1	4180
1805513	●	6-10	34 × 1,1	4530
1805218	●	8-12	34 × 1,1	3920
1806105	●	8-12	34 × 1,1	4115
1784966	●	8-12	34 × 1,1	4242
1784994	●	2-3	41 × 1,3	4570
1785035	●	2-3	41 × 1,3	4700
1774419	●	2-3	41 × 1,3	4920
1805789	●	2-3	41 × 1,3	5450
1785042	●	2-3	41 × 1,3	5800
1784658	●	2-3	41 × 1,3	6060
1774422	●	2-3	41 × 1,3	6100
1805774	●	2-3	41 × 1,3	7000
1774234	●	3-4	41 × 1,3	4560
1784995	●	3-4	41 × 1,3	4570
1805499	●	3-4	41 × 1,3	5080
1788657	●	3-4	41 × 1,3	5450
1784572	●	3-4	41 × 1,3	6030
1773845	●	3-4	41 × 1,3	6220
1805775	●	3-4	41 × 1,3	7000
1774250	●	3-4	41 × 1,3	7870
1785043	●	4-6	41 × 1,3	5800
1805776	●	4-6	41 × 1,3	7000
1805500	●	5-8	41 × 1,3	5080
1785033	●	5-8	41 × 1,3	6450
1805501	●	6-10	41 × 1,3	5080
1789050	●	2-3	54 × 1,6	7300

Пилы ленточные

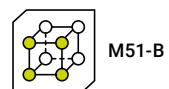

M51-B

Артикул		P, мм	h × b, мм	L, мм
1805197	●	2-3	27 × 0,9	3365
1805523	●	2-3	27 × 0,9	3660
1806158	●	2-3	27 × 0,9	3700
1806146	●	2-3	27 × 0,9	4150
1806159	●	3-4	27 × 0,9	2450
1806160	●	3-4	27 × 0,9	2700
1788802	●	3-4	27 × 0,9	2825
1805937	●	3-4	27 × 0,9	2980
1805933	●	3-4	27 × 0,9	3300
1805198	●	3-4	27 × 0,9	3365
1806147	●	3-4	27 × 0,9	4150
1806021	●	4-6	27 × 0,9	2480
1788803	●	4-6	27 × 0,9	2825
1788804	●	4-6	27 × 0,9	2950
1789045	●	4-6	27 × 0,9	2980
1845439	●	4-6	27 × 0,9	3090
1805199	●	4-6	27 × 0,9	3365
1806225	●	5-8	27 × 0,9	2455
1788805	●	2-3	34 × 1,1	3920
1806022	●	2-3	34 × 1,1	4780
1845440	●	2-3	34 × 1,1	5090
1788806	●	3-4	34 × 1,1	3920
1806233	●	3-4	34 × 1,1	4120
1805678	●	3-4	34 × 1,1	4420
1806023	●	3-4	34 × 1,1	4780
1806033	●	3-4	34 × 1,1	6350
1788807	●	4-6	34 × 1,1	3920
1788808	●	5-8	34 × 1,1	3920
1805913	●	3-4	41 × 1,3	6880
1805763	●	2-3	67 × 1,6	8200

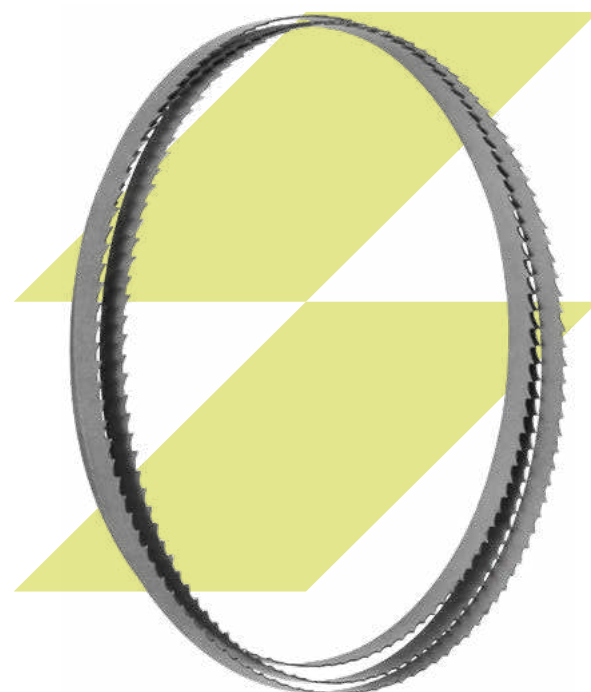

Пилы ленточные



M51-T

Артикул		P, мм	h × b, мм	L, мм
1805197	●	2-3	27 × 0,9	3200
1805523	●	2-3	27 × 0,9	3365
1806158	●	2-3	27 × 0,9	3660
1806146	●	2-3	27 × 0,9	4360
1806159	●	3-4	27 × 0,9	3365
1806160	●	3-4	27 × 0,9	3500
1788802	●	3-4	27 × 0,9	5540
1805937	●	4-6	27 × 0,9	2455
1805933	●	4-6	27 × 0,9	2655
1805198	●	4-6	27 × 0,9	3365
1806147	●	4-6	27 × 0,9	3700
1806021	●	4-6	27 × 0,9	3960
1788803	●	6-10	27 × 0,9	2910
1788804	●	10-14	27 × 0,9	2700
1789045	●	10-14	27 × 0,9	2845
1845439	●	2-3	34 × 1,1	4100
1805199	●	2-3	34 × 1,1	4400
1806225	●	3-4	34 × 1,1	4420
1788805	●	3-4	34 × 1,1	4510
1806022	●	2-3	41 × 1,3	4710
1845440	●	2-3	41 × 1,3	6490
1788806	●	3-4	41 × 1,3	4570
1806233	●	3-4	41 × 1,3	6220
1805678	●	2-3	54 × 1,6	7100
1806023	●	2-3	54 × 1,6	9000

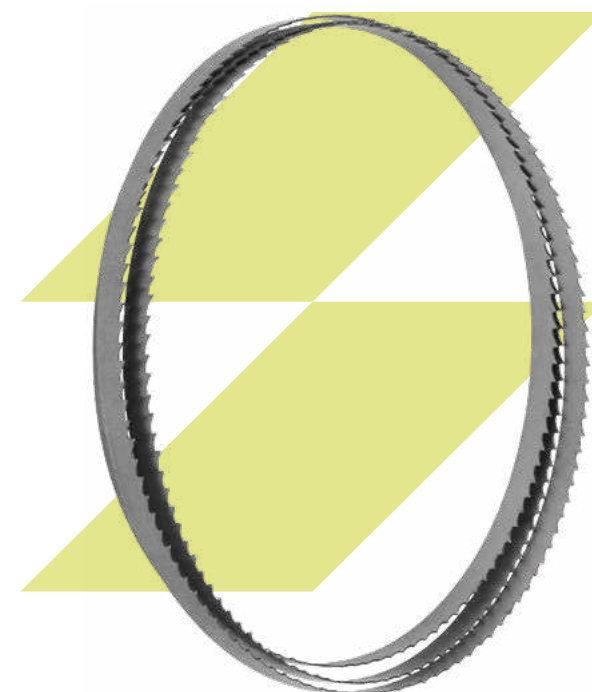

Пилы дисковые сегментные для металла

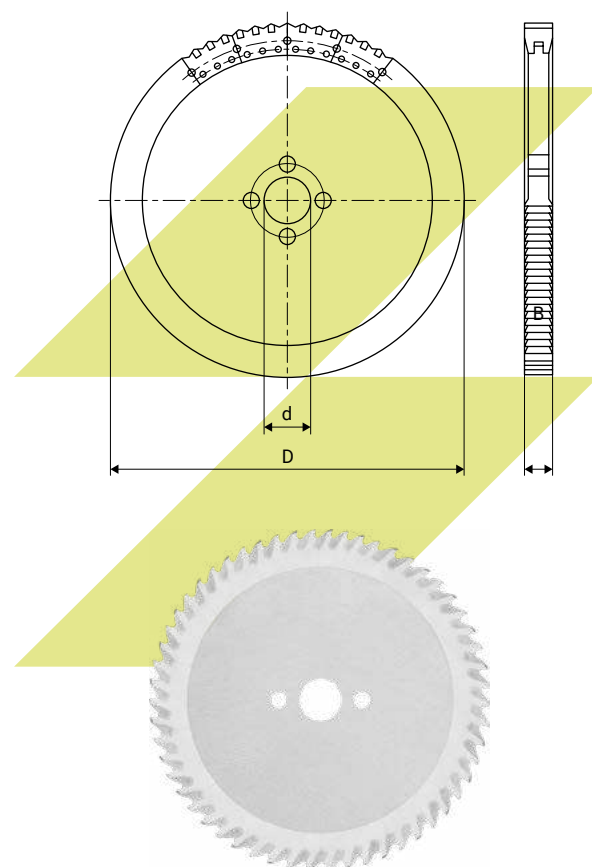
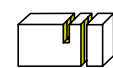

Артикул	Обозначение по ГОСТ	D, мм	B, мм	d, мм	Сегмент, шт	Z, шт	Z/сегмент
1378409	2257-0152	275,0	5,0	32,0	14	56	4
1103521	2257-0153	315,0	5,0	40,0	14	56	4
104181	2257-0204	350,0	5,0	32,0	14	84	6
1171705	2257-0154	350,0	5,0	32,0	14	56	4
104182	2257-0254	350,0	5,0	32,0	14	112	8
104184	2257-0156	410,0	6,0	70,0	18	72	4
104188	2257-0157	500,0	6,0	50,0	18	72	4
104190	2257-0158	510,0	6,5	70,0	18	72	4
104192	2257-0159	610,0	6,5	80,0	20	80	4
104194	2257-0161	630,0	6,5	80,0	20	80	4
104195	2257-0211	630,0	6,5	80,0	20	120	6
104198	2257-0162	710,0	6,5	80,0	24	96	4
104199	2257-0262	710,0	6,5	80,0	24	192	8
104202	2257-0165	1010,0	8,0	120,0	30	120	4

Сегменты к пилам дисковым сегментным для металла

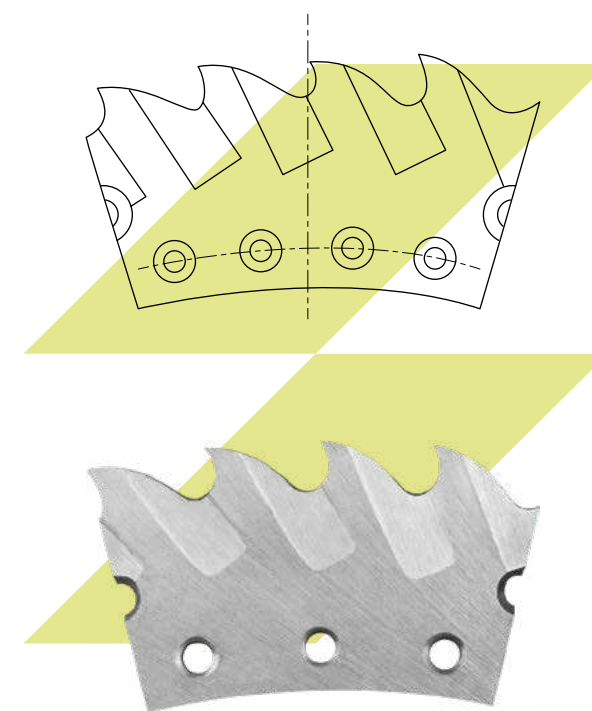
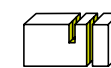

Артикул	Обозначение по ГОСТ	D пилы, мм	B, мм	Z/сегмент
108933	2257-0151/002	250,0	5,0	4
1135805	2257-0201/002	250,0	5,0	6
1104609	2257-0152/002	275,0	5,0	4
108937	2257-0202/002	275,0	5,0	6
1148073	2257-0252/002	275,0	5,0	8
108938	2257-0153/002	315,0	5,0	4
1127424	2257-0203/002	315,0	5,0	6
1127425	2257-0253/002	315,0	5,0	8
108939	2257-0154/002	350,0	5,0	4
108941	2257-0204/002	350,0	5,0	6
108943	2257-0155/002	400,0	6,0	4
108946	2257-0156/002	410,0	6,0	4
108947	—	425,0	6,0	4
108948	—	425,0	6,0	6
108949	—	425,0	6,0	8
108951	2257-0157/002	500,0	6,0	4
108953	2257-0207/002	500,0	6,0	6
108954	2257-0257/002	500,0	6,0	8
108958	2257-0158/002	510,0	6,5	4
108962	2257-0159/002	610,0	6,5	4
108963	2257-0161/002	630,0	6,5	4
108968	2257-0162/002	710,0	6,5	4
108971	2257-0212/002	710,0	6,5	6
108972	2257-0262/002	710,0	6,5	8
108973	2257-0163/002	800,0	7,0	4
1105697	2257-0213/002	800,0	7,0	6
108978	—	810,0	7,0	4
108982	2257-0165/002	1010,0	8,0	4
108986	2257-0215/002	1010,0	8,0	6
108987	2257-0265/002	1010,0	8,0	8
108990	2257-0167/002	1430,0	12,5	4
108994	2257-0171/002	2000,0	14,5	4

Полотна машинные односторонние



P6M5



Машинные

Артикул		L, мм	P	b, мм	h, мм
0114068	●	500	4	2,0	40
0114066	●	450	4	2,0	40
0114065	●	450	4	2,0	32
1140358	●	450	4	1,6	32
0104966	●	400	4	2,0	40
0114064	●	400	4	2,0	32

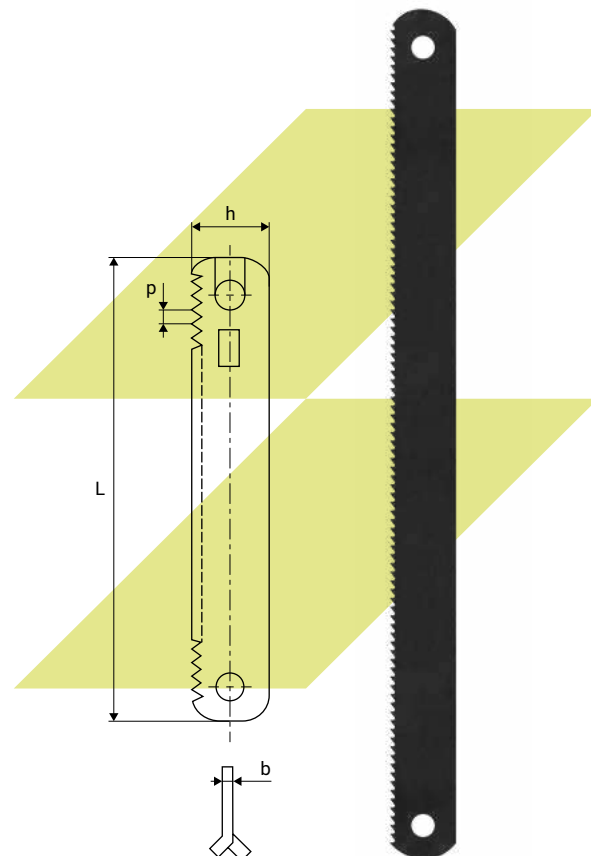

Для заметок

Area for notes with horizontal dashed lines.

Отрезные работы

Отрезные работы

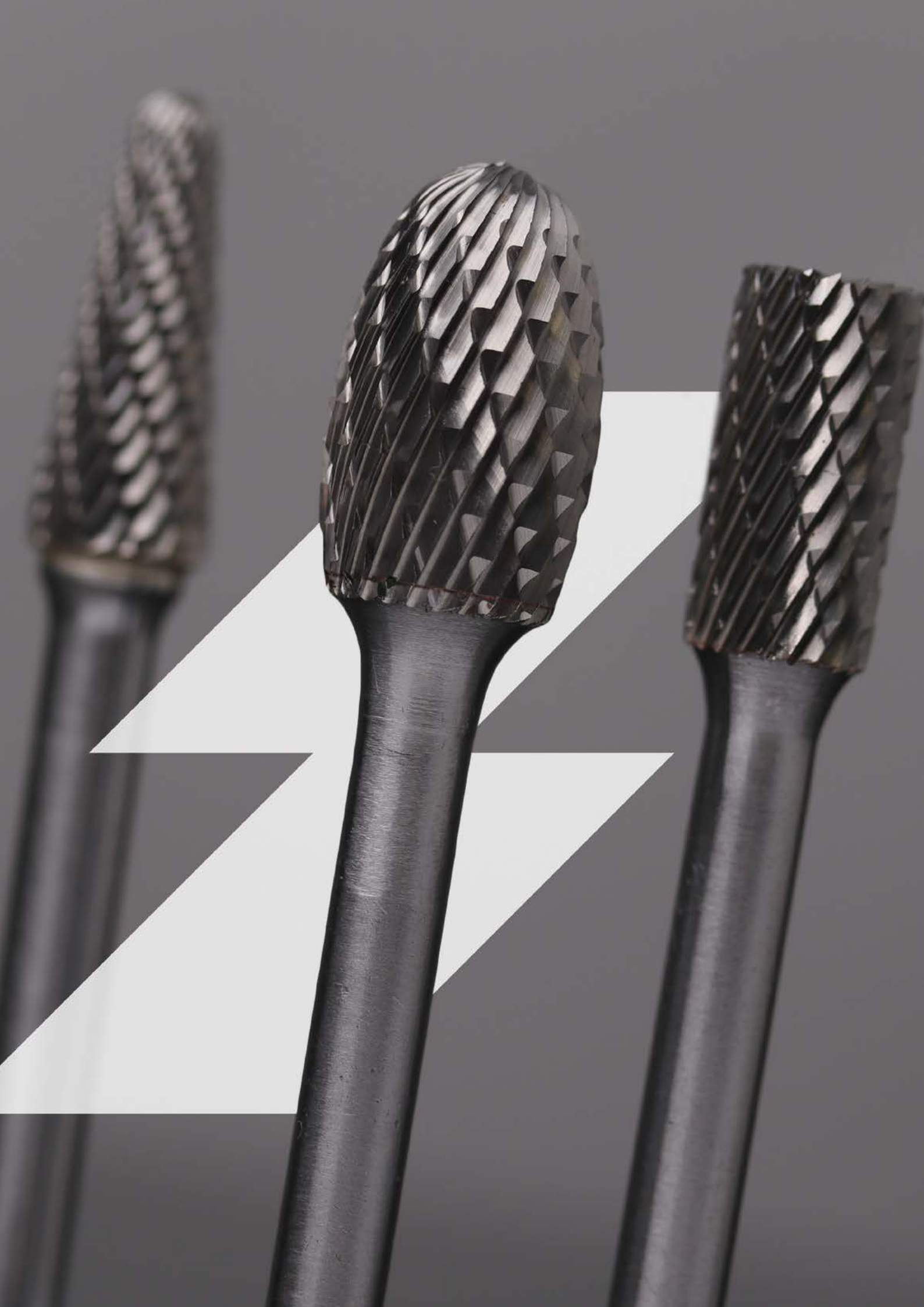

Зачистка сварных швов

Борфрезы твердосплавные	582
Универсального применения	582
Набор борфрез	597

Борфрезы твердосплавные

Борфрезы предназначены для работ по незакаленной стали, латуни, меди, чугуну, бронзе, нержавеющей стали, титану. Используются для завершающей обработки и подгонки форм и поверхностей. Универсальны при работе по различным металлическим поверхностям. Крестообразное расположение зубьев повышает эффективность работы и уменьшает образование стружки. Изготовлены из высококачественного твердого сплава, что обеспечивает высокую прочность и износостойкость инструмента.



Наборы борфрез

В набор входят борфрезы из твердого сплава часто используемых форм и размеров для обработки кромок и зачистки сварочных швов, удаления заусенцев и снятия фаски, шлифования различных поверхностей и труднодоступных мест. Подходят для алюминия, цветных металлов, стали, чугуна, титана и нержавеющей стали. Прочная коробка защищает инструменты от загрязнений и повреждений.



Условные обозначения

Основные размеры

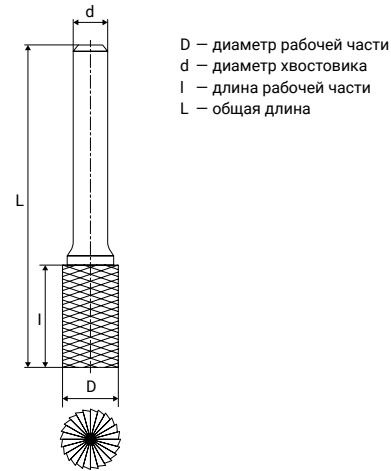

Варианты обработки

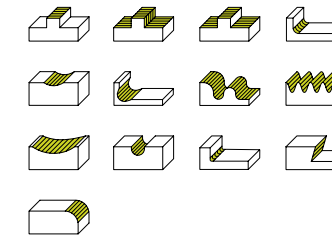

Обрабатываемый материал

P	Стали
M	Нержавеющая сталь
K	Чугуны
N	Цветные металлы
S	Жаропрочные сплавы
H	Закаленная сталь
■	Оптимальное применение
▒	Возможное применение
□	Не применяется



Обозначение стандарта



Обозначение инструментального материала



Вид зуба

Тип борфрезы

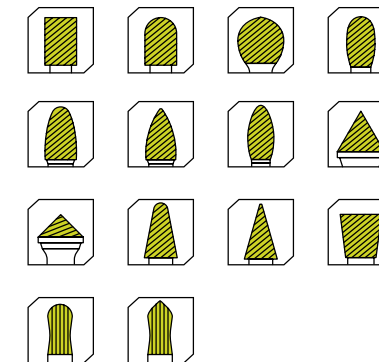

Вид насечки



Наличие инструмента

- На складе в Нижнем Новгороде
- Под заказ

Борфрезы

Борфрезы повышенной точности						
Вид обработки						
Стандарт	ГОСТ 34202-2017	ГОСТ 34202-2017	ГОСТ 34202-2017	ГОСТ 34202-2017	ГОСТ 34202-2017	ГОСТ 34202-2017
Тип	A	B	C	D	E	F
Тип зуба	M	M	M	M	M	M
Материал	ВК8	ВК8	ВК8	ВК8	ВК8	ВК8
Заточка	Двойная	Двойная	Двойная	Двойная	Двойная	Двойная
Диапазон	1,5–16,0	1,5–16,0	2,0–16,0	2,0–25,0	3,0–16,0	3,0–16,0
Страница	582	583	584	585	586	587

Борфрезы повышенной точности						
Вид обработки						
Стандарт	ГОСТ 34202-2017	ГОСТ 34202-2017	ГОСТ 34202-2017	ГОСТ 34202-2017	ГОСТ 34202-2017	ГОСТ 34202-2017
Тип	G	H	J	K	L	M
Тип зуба	M	M	M	M	M	M
Материал	ВК8	ВК8	ВК8	ВК8	ВК8	ВК8
Заточка	Двойная	Двойная	Одинарная	Одинарная	Двойная	Двойная
Диапазон	3,0–16,0	3,0–16,0	3,0–16,0	3,0–16,0	3,0–20,0	3,0–20,0
Страница	588	589	590	591	592	593

Борфрезы

Борфрезы повышенной точности			
Вид обработки			
Стандарт	ГОСТ 34202-2017	ГОСТ 34202-2017	ГОСТ 34202-2017
Тип	N	XP	XS
Тип зуба	M	M	M
Материал	ВК8	ВК8	ВК8
Заточка	Двойная	Одинарная	Одинарная
Диапазон	3,0–16,0	4,0–8,0	4,0–18,0
Страница	594	595	596

Набор борфрез

Материал	ВК8
Страница	597

Борфрезы твердосплавные цилиндрические с гладким торцом, тип А



Артикул	D, мм	d, мм	l, мм	L, мм
1584264*	1,5	3,0	10,0	50,0
1337631*	2,0	3,0	10,0	38,0
1584265*	2,5	3,0	10,0	50,0
1337632*	3,0	3,0	13,0	38,0
1584266*	3,0	3,0	13,0	50,0
1337633	4,0	3,0	13,0	51,0
1337634	6,0	6,0	16,0	61,0
1337635	8,0	6,0	20,0	65,0
1416253	9,5	6,0	20,0	65,0
1337636	10,0	6,0	20,0	65,0
1337637	12,0	6,0	25,0	70,0
1425083	12,0	8,0	25,0	70,0
1337638	14,0	6,0	25,0	70,0
1337639	16,0	6,0	25,0	70,0
1425084	16,0	8,0	25,0	70,0

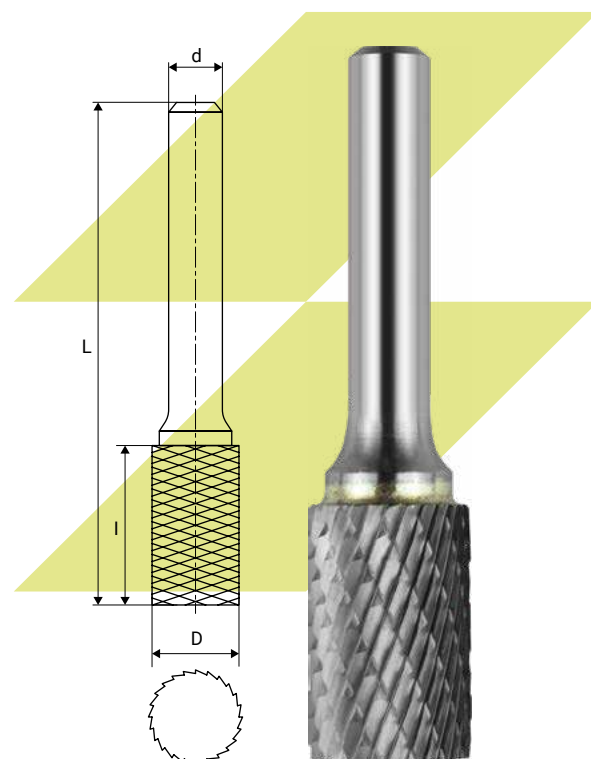

* цельная твердосплавная борфреза

Борфрезы твердосплавные цилиндрические с зубчатым торцом, тип В



Артикул	D, мм	d, мм	l, мм	L, мм
1584267*	1,5	3,0	10,0	50,0
1417176	2,5	3,0	14,0	30,0
1584268*	2,5	3,0	14,0	50,0
1478523*	3,0	3,0	14,0	50,0
1337640	6,0	6,0	16,0	61,0
1337641	8,0	6,0	20,0	65,0
1337642	10,0	6,0	20,0	65,0
1337643	12,0	6,0	25,0	70,0
1337644	14,0	6,0	25,0	70,0
1337645	16,0	6,0	25,0	70,0

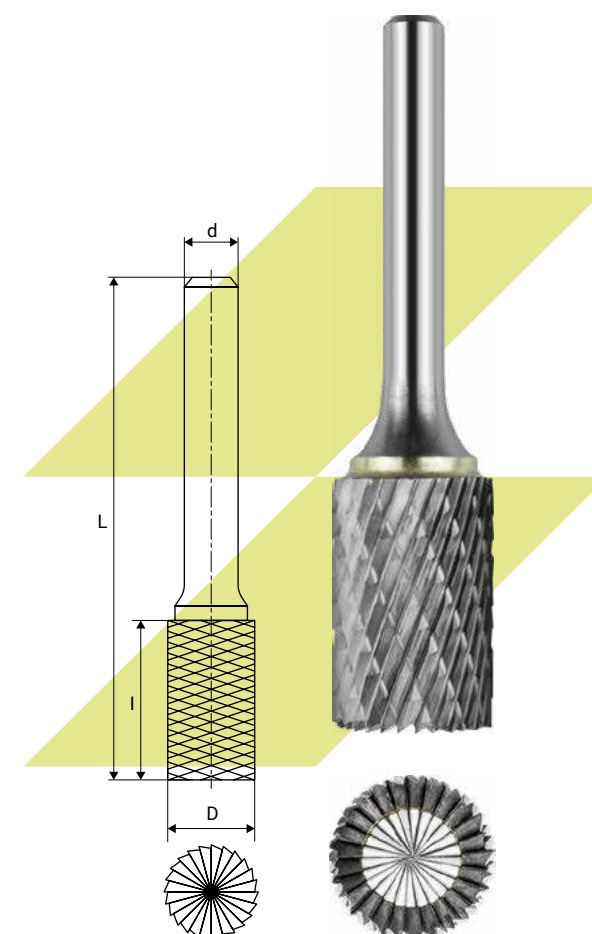

* цельная твердосплавная борфреза

Борфрезы твердосплавные сфероцилиндрические, тип С

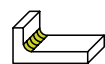

ГОСТ 34202-2017

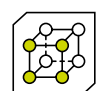

ВК8

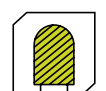

Тип С



М Средний

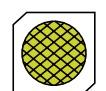

Двойная

Артикул	D, мм	d, мм	l, мм	L, мм
1337646*	2,0	3,0	10,0	38,0
1337647*	3,0	3,0	13,0	38,0
1337648	4,0	3,0	16,0	61,0
1337649	6,0	6,0	16,0	61,0
1337650	8,0	6,0	20,0	65,0
1337651	10,0	6,0	20,0	65,0
1337652	12,0	6,0	25,0	70,0
1425081	12,0	8,0	25,0	70,0
1417614	12,5	8,0	25,0	70,0
1416252	12,7	6,0	25,0	70,0
1337653	14,0	6,0	25,0	70,0
1337654	16,0	6,0	25,0	70,0
1425082	16,0	8,0	25,0	70,0

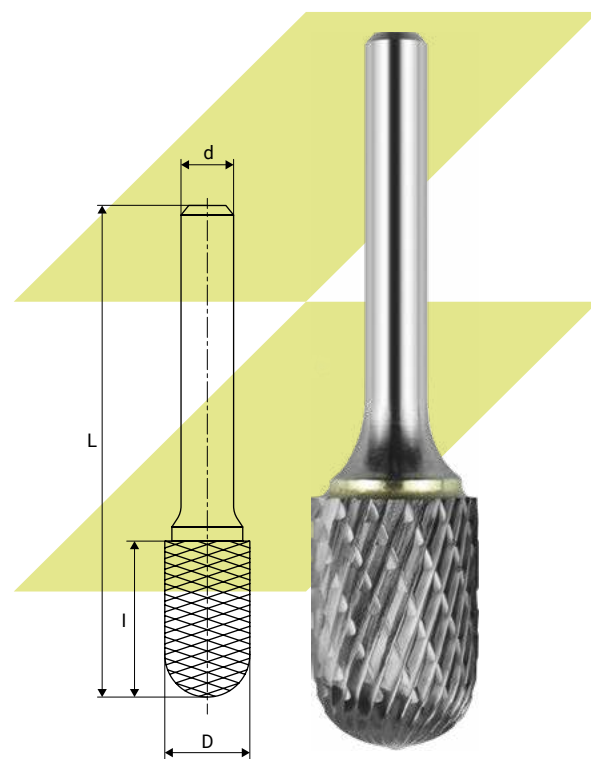

* цельная твердосплавная борфреза

Борфрезы твердосплавные сферические, тип D

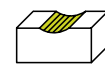

ГОСТ 34202-2017

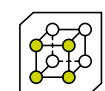

ВК8



Тип D



М Средний

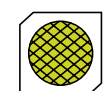

Двойная

Артикул	D, мм	d, мм	l, мм	L, мм
1337655*	2,0	3,0	1,8	38,0
1337656*	3,0	3,0	2,7	38,0
1337657	4,0	3,0	3,6	42,0
1337658*	6,0	6,0	5,4	50,0
1337659	8,0	6,0	7,2	52,0
1337660	10,0	6,0	9,0	54,0
1337661	12,0	6,0	10,8	54,0
1425077	12,0	8,0	10,8	54,0
1337662	14,0	6,0	12,6	55,0
1337663	16,0	6,0	14,4	59,0
1425078	16,0	8,0	14,4	59,0
1418602	20,0	6,0	16,5	62,0
1531015	25,0	6,0	22,0	67,0

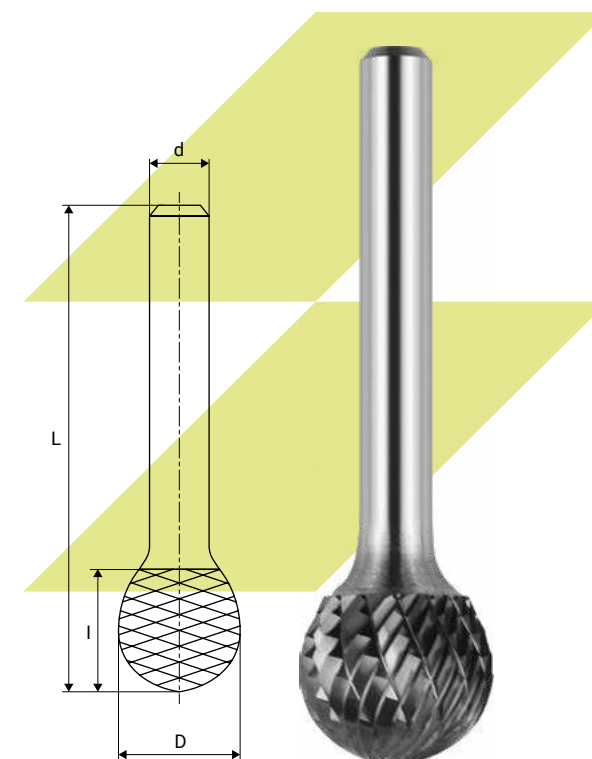

* цельная твердосплавная борфреза

Борфрезы твердосплавные овалыные, тип E



Артикул	D, мм	d, мм	l, мм	L, мм
1337664*	3,0	3,0	6,0	38,0
1337665	6,0	6,0	10,0	55,0
1337666	8,0	6,0	13,0	58,0
1337667	10,0	6,0	16,0	61,0
1337668	12,0	6,0	20,0	65,0
1337669	14,0	6,0	22,0	67,0
1337670	16,0	6,0	25,0	70,0

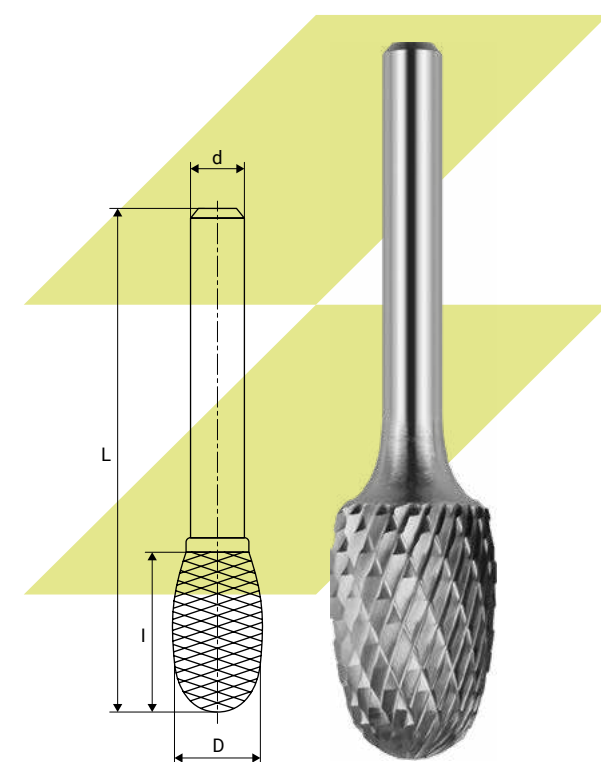

* цельная твердосплавная борфреза

Борфрезы твердосплавные сфероконические, тип F

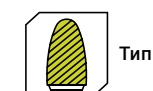
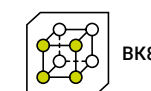

Артикул	D, мм	d, мм	l, мм	L, мм
1337671*	3,0	3,0	13,0	38,0
1337672	6,0	6,0	18,0	63,0
1337673	8,0	6,0	18,0	63,0
1337674	10,0	6,0	20,0	65,0
1337675	12,0	6,0	25,0	70,0
1425073	12,0	8,0	25,0	70,0
1416250	12,7	6,0	25,0	70,0
1337676	16,0	6,0	25,0	70,0
1425074	16,0	8,0	25,0	70,0

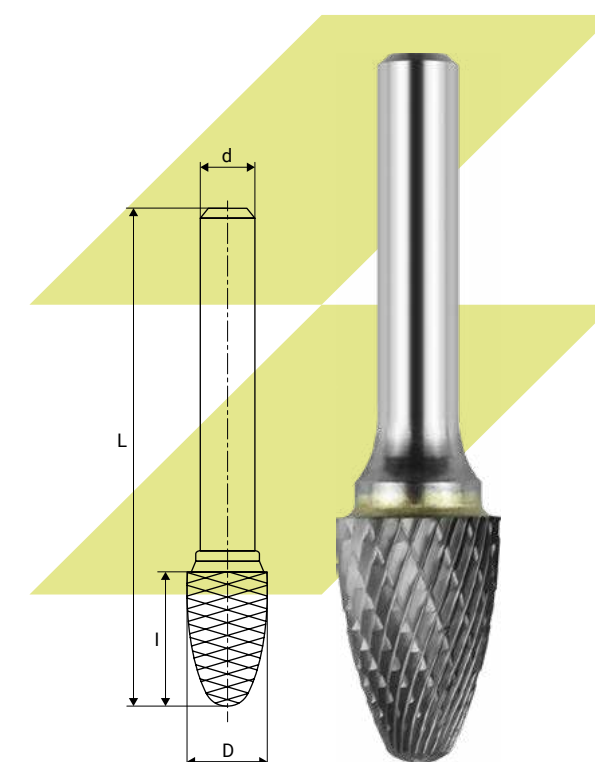

* цельная твердосплавная борфреза

Борфрезы твердосплавные сфероконические с заостренным концом, тип G



ГОСТ 34202-2017



ВК8



Тип G



Средний



Двойная

Артикул	D, мм	d, мм	l, мм	L, мм
1337677*	3,0	3,0	13,0	38,0
1337678	6,0	6,0	18,0	63,0
1337679	8,0	6,0	20,0	65,0
1337680	10,0	6,0	20,0	65,0
1337681	12,0	6,0	25,0	70,0
1425071	12,0	8,0	25,0	70,0
1805395	12,5	6,0	25,0	70,0
1337682	14,0	6,0	25,0	70,0
1337683	16,0	6,0	25,0	70,0
1425072	16,0	8,0	25,0	70,0

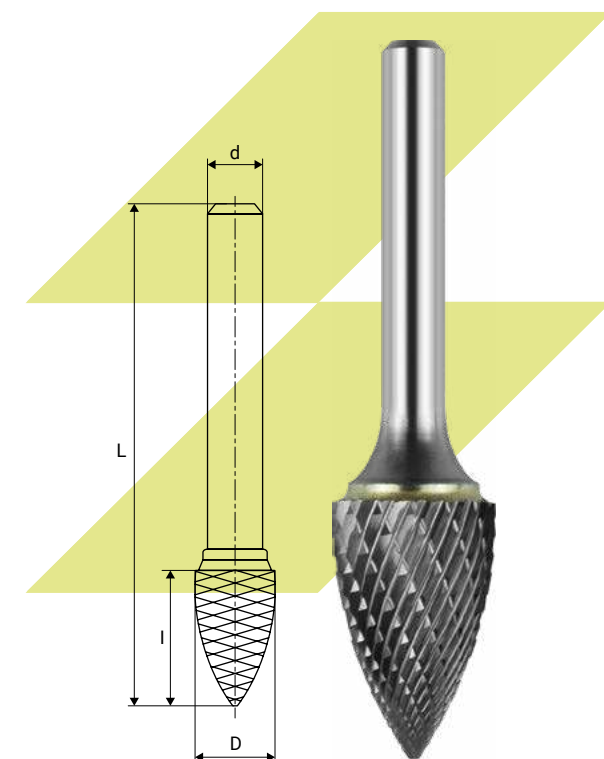

* цельная твердосплавная борфреза

Борфрезы твердосплавные пламевидные, тип H



ГОСТ 34202-2017



ВК8



Тип H



Средний



Двойная

Артикул	D, мм	d, мм	l, мм	L, мм
1337684*	3,0	3,0	7,0	38,0
1337685	6,0	6,0	18,0	63,0
1337686	8,0	6,0	20,0	65,0
1337687	10,0	6,0	25,0	70,0
1337688	12,0	6,0	32,0	77,0
1425075	12,0	8,0	32,0	77,0
1337689	16,0	6,0	36,0	81,0
1425076	16,0	8,0	36,0	81,0

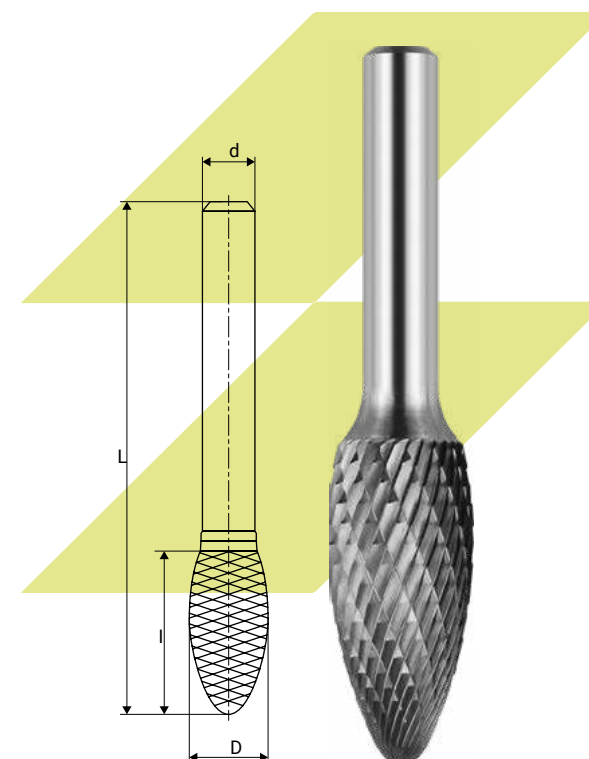

* цельная твердосплавная борфреза

Борфрезы твердосплавные конические с конусностью 60°, тип J

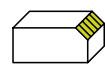

ГОСТ 34202-2017



VK8



Тип J



Средний



Одинарная

Артикул	D, мм	d, мм	l, мм	L, мм
1337690*	3,0	3,0	2,6	38,0
1337691*	6,0	6,0	5,2	50,0
1337692	8,0	6,0	7,0	52,0
1337693	10,0	6,0	8,7	53,0
1337694	12,0	6,0	10,4	55,0
1337695	16,0	6,0	13,8	59,0

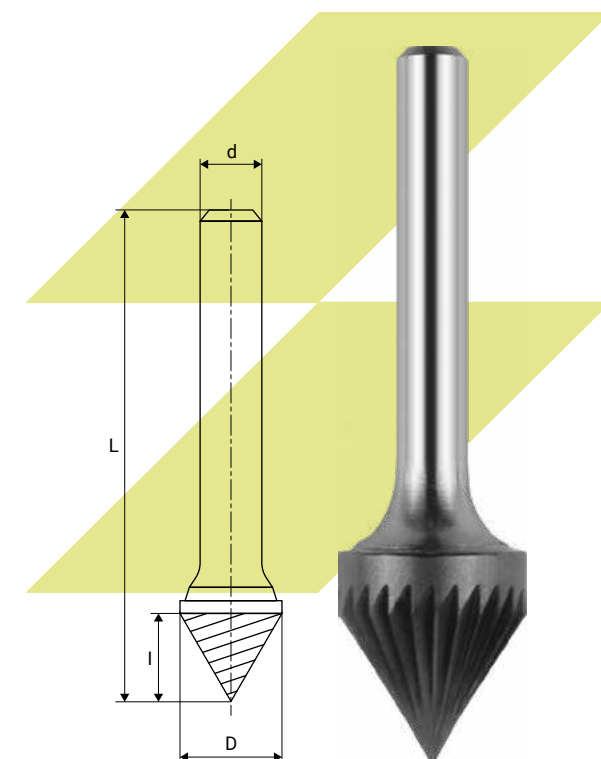

* цельная твердосплавная борфреза

Борфрезы твердосплавные конические с конусностью 90°, тип K

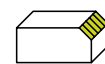

ГОСТ 34202-2017



VK8



Тип K



Средний



Одинарная

Артикул	D, мм	d, мм	l, мм	L, мм
1337696*	3,0	3,0	1,5	38,0
1337697*	6,0	6,0	3,0	48,0
1337698	8,0	6,0	4,0	49,0
1337699	10,0	6,0	5,0	50,0
1337700	12,0	6,0	6,0	51,0
1337701	16,0	6,0	8,0	53,0

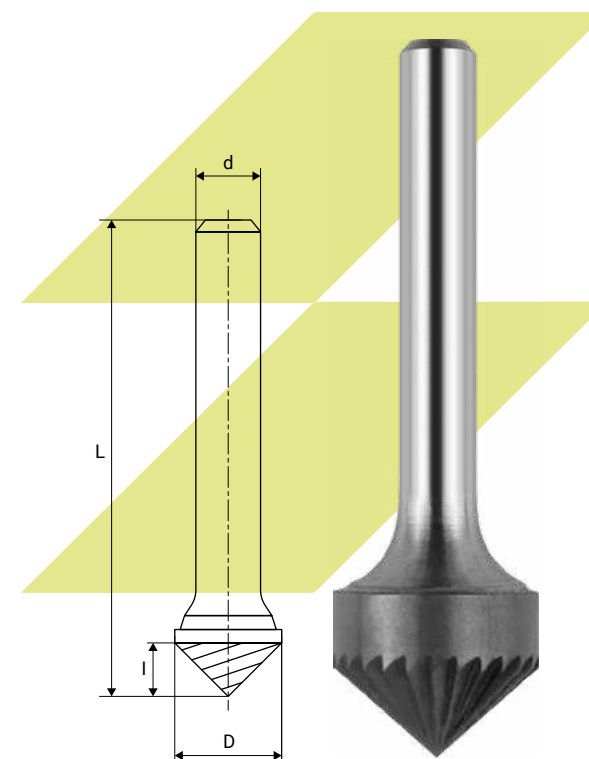

* цельная твердосплавная борфреза

Борфрезы твердосплавные конические с закругленным концом, тип L

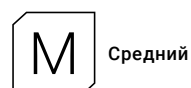
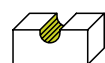

Артикул		D, мм	d, мм	l, мм	L, мм
1337702*	●	3,0	3,0	13,0	38,0
1337703	●	6,0	6,0	16,0	61,0
1337704	●	8,0	6,0	22,0	67,0
1614782*	●	8,0	8,0	22,0	53,0
1418532	●	10,0	6,0	20,0	65,0
1337705	●	10,0	6,0	25,0	70,0
1337706	●	12,0	6,0	28,0	73,0
1425079	●	12,0	8,0	28,0	73,0
1416251	●	12,7	6,0	28,0	73,0
1337707	●	14,0	6,0	28,0	73,0
1337708	●	16,0	6,0	33,0	78,0
1425080	●	16,0	8,0	33,0	78,0
112664	●	20,0	10,0	33,0	90,0

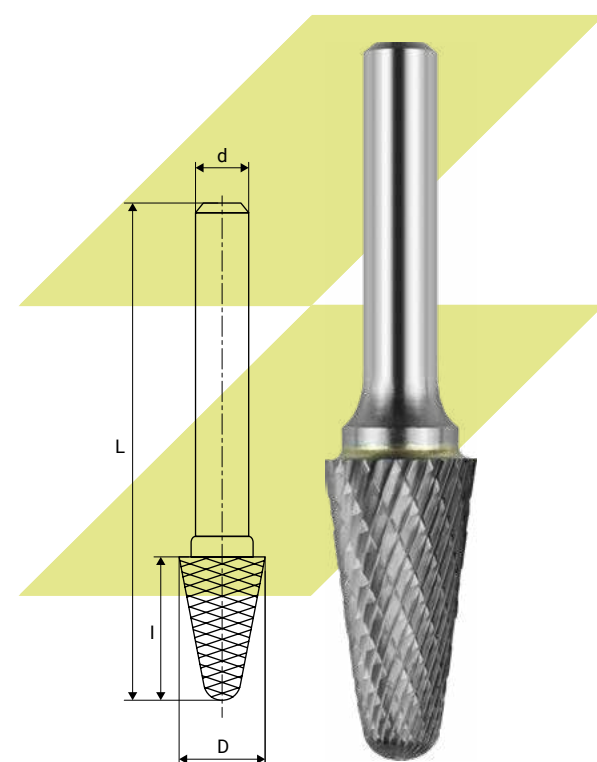

* цельная твердосплавная борфреза

Борфрезы твердосплавные конические с заостренным концом, тип M

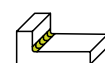

Артикул		D, мм	d, мм	l, мм	L, мм
1337709*	●	3,0	3,0	11,0	38,0
1337710	●	6,0	6,0	18,0	63,0
1337711	●	8,0	6,0	20,0	65,0
1337712	●	10,0	6,0	20,0	65,0
1337713	●	12,0	6,0	25,0	70,0
1337714	●	14,0	6,0	25,0	70,0
1337715	●	16,0	6,0	25,0	70,0
1418601	●	20,0	6,0	25,0	70,0

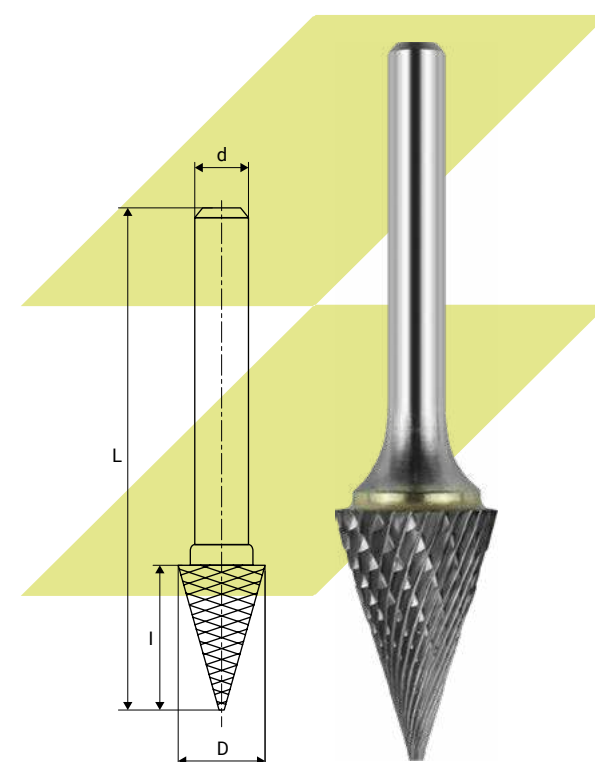

* цельная твердосплавная борфреза

Борфрезы твердосплавные конические в форме обратного конуса, тип N



ГОСТ
34202-2017



VK8



Тип N



Средний



Двойная

Артикул		D, мм	d, мм	l, мм	L, мм
1337716*	●	3,0	3,0	7,0	38,0
1337717	●	6,0	6,0	7,0	53,0
1337718	●	12,0	6,0	13,0	58,0
1337719	●	16,0	6,0	16,0	61,0

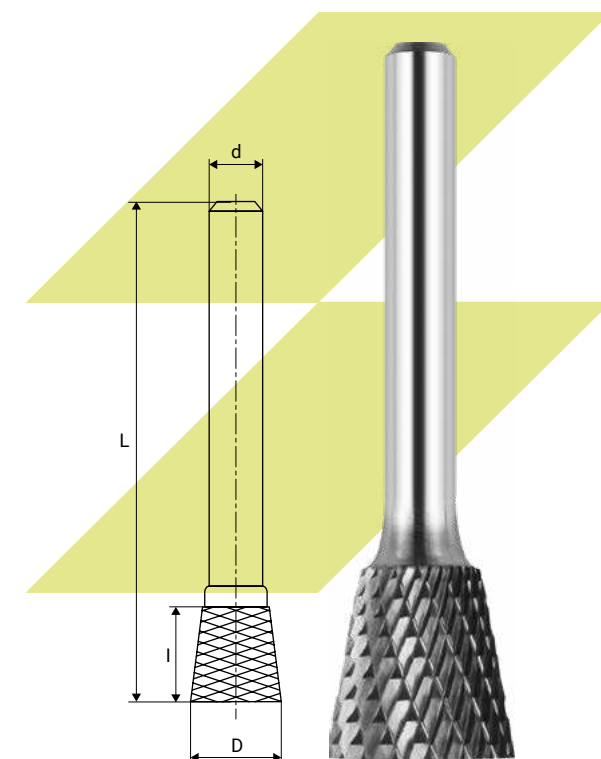

* цельная твердосплавная борфреза

Борфрезы твердосплавные сферогрушевидные, тип XP

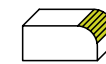

ГОСТ
34202-2017



VK8



Тип XP



Средний



Одинарная

Артикул		D, мм	d, мм	l, мм	L, мм
1139252*	●	4,0	4,0	10,0	27,0
112584*	●	6,0	6,0	12,0	32,0
112595*	●	8,0	8,0	16,0	40,0

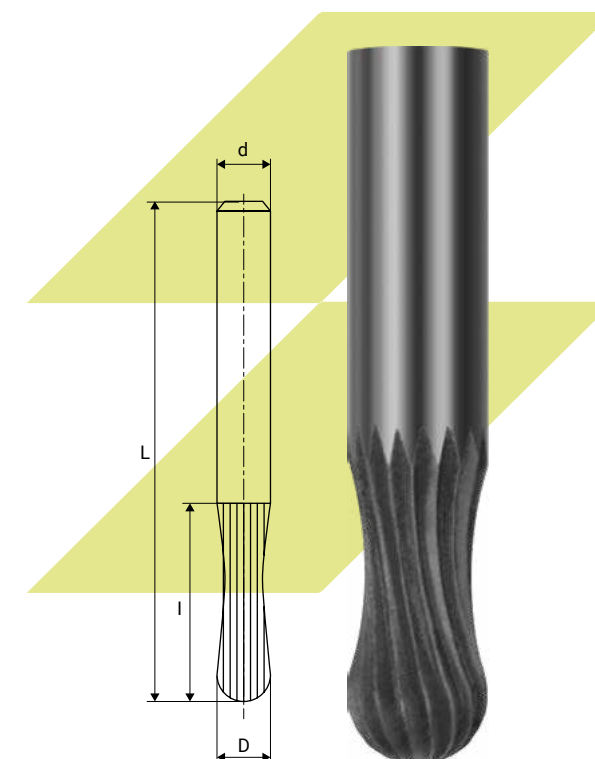

* цельная твердосплавная борфреза

Борфрезы твердосплавные эллипсоидные, тип XS

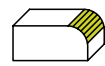

ГОСТ
34202-2017

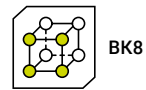

VK8



Тип XS



Средний



Одинарная

Артикул		D, мм	d, мм	l, мм	L, мм
1105828*	●	4,0	4,0	10,0	25,0
112586*	●	6,0	6,0	16,0	32,0
112597*	●	8,0	8,0	20,0	40,0
112617	●	10,0	8,0	20,0	40,0
112633	●	12,5	8,0	25,0	70,0
112644	●	14,0	8,0	25,0	70,0
1178414	●	16,0	8,0	31,0	76,0

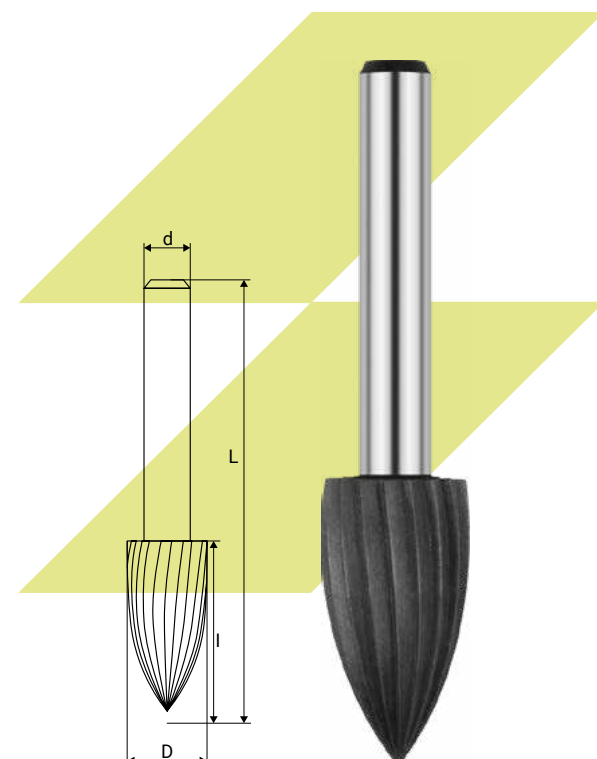

* цельная твердосплавная борфреза

Набор борфрез

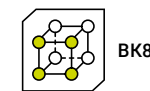

VK8

Артикул		D _{min} , мм	D _{max} , мм	d, мм	Кол-во в наборе, шт
1851568	●	3,0	3,0	3,0	10
1851566	●	3,0	6,0	3,0	10
1851567	●	6,0	6,0	3,0	10
1851561	●	6,0	10,0	6,0	5
1851563	●	6,0	10,0	6,0	8
1851564	●	6,0	12,0	6,0	8
1851565	●	6,0	16,0	6,0	10
1851574	●	10,0	10,0	6,0	3
1851562	●	12,0	12,0	6,0	5



Обработка зубчатых и шлицевых соединений

Долбяки зуборезные из быстрорежущей стали	609
Хвостовые	609
Дисковые	622
Чашечные	639
Фрезы дисковые зуборезные	648
Мелкомодульные, комплект из 8 штук	648
Модульные, комплект из 8 штук	649
Фрезы червячные из быстрорежущей стали	650
Мелкомодульные для цилиндрических зубчатых колес с эвольвентным профилем	650
Чистовые для цилиндрических зубчатых колес с эвольвентным профилем	653
Чистовые для шлицевых валов с эвольвентным профилем	655
Для шлицевых валов с прямобочным профилем	656
Для нарезания зубьев звездочек к приводным роликовым и втулочным цепям	658
Чистовые однозаходные для зубчатых цилиндрических колес передач Новикова	659
Фрезы червячные из твердого сплава	660
Протяжки шпоночные из быстрорежущей стали	661
Резцы зубострогальные из быстрорежущей стали	663

Долбяки зуборезные из быстрорежущей стали

Долбяки зуборезные используются в качестве основного элемента зубодоблѣжных станков. Представляют собой зубчатые колеса с режущими элементами определённой степени заточки. Используются для выполнения зубцов, реек и венцов. Могут применяться как на обычных обрабатывающих станках, так и на станках с ЧПУ. Изготавливаются из быстрорежущей износостойкой стали, способной выдержать максимальные нагрузки.



Фрезы дисковые зуборезные

Фрезы дисковые зуборезные предназначены для предварительной и чистовой нарезки прямозубых цилиндрических или конических колес, а также шевронных колес с канавкой между зубчатыми венцами на ободке для выхода инструмента. Также используются при изготовлении конических колес с прямым зубом. Профиль дисковых модульных фрез всегда точно соответствует профилю впадины колеса с самым меньшим числом зубьев в соответствующем ему в этом номере диапазоне.



Фрезы червячные из быстрорежущей стали

Червячные фрезы используются для обработки прямозубых, косозубых и шевронных цилиндрических колес, нарезания зубьев червячных колес с различными видами зацепления. Работают по методу обката. Изготавливаются из быстрорежущей износостойкой стали, способной выдержать максимальные нагрузки.



Протяжки шпоночные из быстрорежущей стали

Шпоночные протяжки используются для обработки внутренних или наружных поверхностей металлических заготовок. Срезание слоев материала происходит при поступательном движении, в результате чего обеспечиваются заданная точность и шероховатость. Изготавливаются из быстрорежущей износостойкой стали, способной выдержать максимальные нагрузки.



Резцы зубострогальные из быстрорежущей стали

Резцы зубострогальные применяются для нарезания зубчатых, зачастую прямозубых конических колес на зубострогальных станках методом обкатки. Работают по принципу строгания: перемещаются вдоль поверхности колеса, удаляя металл и формируя зубья. Изготавливаются из быстрорежущей износостойкой стали, способной выдержать максимальные нагрузки.



Условные обозначения

Основные размеры

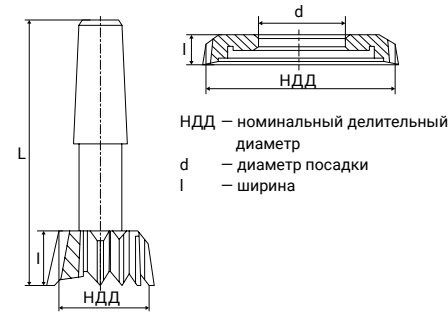

НДД – номинальный делительный диаметр
I – длина рабочей части
L – общая длина

Тип обработки

Обработка зубчатых и шлицевых соединений

Наличие инструмента

На складе в Нижнем Новгороде
 Под заказ

Обозначение стандарта

Обозначение инструментального материала

Класс точности/Квалитет

Угол профиля

Номинальный делительный диаметр

Обрабатываемый материал

Стали
 Нержавеющая сталь
 Чугуны
 Цветные металлы
 Жаропрочные сплавы
 Закаленная сталь

Оптимальное применение
 Возможное применение
 Не применяется

Долбяки зуборезные из быстрорежущей стали

Вид обработки	Хвостовые чистовые мелко модульные для обработки зубчатых колёс с эвольвентным профилем				Хвостовые чистовые для обработки прямозубых и косозубых цилиндрических зубчатых колёс		
Стандарт	ГОСТ 10059-80	ГОСТ 10059-80	ГОСТ 10059-80	ГОСТ 10059-80	ГОСТ 9323-79	ГОСТ 9323-79	ГОСТ 9323-79
Номинальный делительный диаметр	16 мм	25 мм	25 мм	25 мм	25 мм	25 мм	38 мм
Угол профиля	20°	20°	20°	20°	20°	20°	20°
Материал	P6M5	P6M5	P18	P18	P6M5	P6M5	P6M5
Класс точности	A	B	A	AA	B	B	B
Диапазон	m 0,8	m 0,3–m 0,9	m 0,4–m 0,7	m 0,2–m 0,9	m 1,0–m 3,0	m 1,0–m 2,5	m 1,25–m 3,75
Страница	609	610	611	612	613	614	615



Вид обработки	Хвостовые чистовые для обработки прямозубых и косозубых цилиндрических зубчатых колёс		Хвостовые для обработки зубьев валов и отверстий шлицевых соединений с эвольвентным профилем			
Стандарт	ГОСТ 9323-79	ГОСТ 6762-79	ГОСТ 6762-79	ГОСТ 6762-79	ГОСТ 6762-79	ГОСТ 6762-79
Номинальный делительный диаметр	38 мм	12 мм	16 мм	20 мм	25 мм	38 мм
Угол профиля	20°	30°	30°	30°	30°	30°
Материал	P6M5	P6M5	P6M5	P6M5	P6M5	P6M5
Класс точности	A	A	A	A	A	A
Диапазон	m 1,0–m 4,0	m 0,8–m 1,25	m 0,8–m 2,0	m 0,5–m 1,5	m 0,8–m 3,5	m 2,0–m 5,0
Страница	616	617	618	619	620	621



Долбяки зуборезные из быстрорежущей стали

Вид обработки	Дисковые чистовые мелко модульные для обработки зубчатых колёс с эвольвентным профилем	
Стандарт	ГОСТ 10059-80	ГОСТ 10059-80
Номинальный делительный диаметр	40 мм	63 мм
Угол профиля	20°	20°
Материал	P18	P18
Класс точности	B	A
Диапазон	m 0,7–m 0,9	m 0,3–m 0,8
Страница	622	623



Вид обработки	Дисковые чистовые для обработки прямозубых и косозубых цилиндрических зубчатых колёс						
Стандарт	ГОСТ 9323-79	ГОСТ 9323-79	ГОСТ 9323-79	ГОСТ 9323-79	ГОСТ 9323-79	ГОСТ 9323-79	ГОСТ 9323-79
Номинальный делительный диаметр	80 мм	80 мм	80 мм	80 мм	80 мм	100 мм	100 мм
Угол профиля	20°	20°	20°	20°	20°	20°	20°
Материал	P6M5	P18	P6M5	P6M5K5	P18	P6M5	P6M5K5
Класс точности	B	B	A	A	A	B	B
Диапазон	m 1,25–m 4,5	m 1,25–m 4,5	m 1,25–m 4,5	m 1,25–m 2,25	m 1,0–m 5,0	m 1,25–m 5,0	m 1,0–m 5,0
Страница	624	625	626	627	628	629	630



Долбяки зуборезные из быстрорежущей стали

	Дисковые чистовые для обработки прямозубых и косозубых цилиндрических зубчатых колёс					
Вид обработки						
Стандарт	ГОСТ 9323-79	ГОСТ 9323-79	ГОСТ 9323-79	ГОСТ 9323-79	ГОСТ 9323-79	ГОСТ 9323-79
Номинальный делительный диаметр	100 мм	100 мм	100 мм	100 мм	125 мм	160 мм
Угол профиля	20°	20°	20°	20°	20°	20°
Материал	P18	P6M5	P6M5K5	P18	P6M5	P6M5
Класс точности	B	A	A	A	B	B
Диапазон	m 125–m 6,5	m 1,0–m 4,5	m 2,0–m 4,0	m 1,25–m 6,5	m 5,0–m 9,0	m 6,0–m 9,0
Страница	631	632	633	634	635	636



	Дисковые чистовые для обработки зубьев валов и отверстий шлицевых соединений с эвольвентным профилем		Чашечные чистовые для обработки прямозубых и косозубых цилиндрических зубчатых колёс			
Вид обработки						
Стандарт	ГОСТ 6762-79	ГОСТ 6762-79	ГОСТ 9323-79	ГОСТ 9323-79	ГОСТ 9323-79	ГОСТ 9323-79
Номинальный делительный диаметр	75 мм	100 мм	50 мм	50 мм	80 мм	80 мм
Угол профиля	30°	30°	20°	20°	20°	20°
Материал	P6M5	P6M5	P6M5	P6M5	P6M5	P6M5
Класс точности	A	A	B	A	B	A
Диапазон	m 1,0–m 5,0	m 2,0–m 3,5	m 1,5–m 2,75	m 1,0–m 3,5	m 2,25–m 3,5	m 1,5–m 3,0
Страница	637	638	639	640	641	642



Долбяки зуборезные из быстрорежущей стали

	Чашечные чистовые для обработки прямозубых и косозубых цилиндрических зубчатых колёс			Чашечные чистовые для обработки зубьев валов и отверстий шлицевых соединений с эвольвентным профилем	
Вид обработки					
Стандарт	ГОСТ 9323-79	ГОСТ 9323-79	ГОСТ 9323-79	ГОСТ 6762-79	ГОСТ 6762-79
Номинальный делительный диаметр	100 мм	100 мм	125 мм	50 мм	100 мм
Угол профиля	20°	20°	20°	30°	30°
Материал	P6M5	P6M5	P6M5	P6M5	P6M5
Класс точности	B	A	A	A	A
Диапазон	m 1,0–m 4,5	m 1,0–m 4,5	m 5,0	m 0,5–m 3,5	m 3,5–m 10,0
Страница	643	644	645	646	647



Фрезы дисковые зуборезные

	Комплект 8 штук	Комплект 8 штук
Вид обработки		
Стандарт	ГОСТ 13838-68	ОСТ 2И-41-14-87 / ГОСТ 10996-64
Номинальный делительный диаметр	—	—
Угол профиля	20°	20°
Материал	P6M5	P6M5
Класс точности	—	—
Диапазон	m 0,3–m 0,9	m 1,0–m 12,0
Страница	648	649

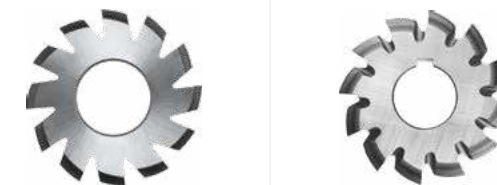

Фрезы червячные из быстрорежущей стали

Вид обработки	Мелкомодульные для цилиндрических зубчатых колес с эвольвентным профилем			Цельные чистовые для цилиндрических зубчатых колес с эвольвентным профилем		Чистовые для шлицевых валов с эвольвентным профилем
Стандарт	ГОСТ 10331-81	ГОСТ 10331-81	ГОСТ 10331-81	ГОСТ 9324-2015	ГОСТ 9324-2015	ГОСТ 6637-80
Диаметр	25 мм	32 мм	40 мм	40,0–175,0	40,0–160,0	50,0–80,0 мм
Угол профиля	20°	20°	20°	20°	20°	30°
Материал	P6M5	P6M5	P6M5	P6M5	P6M5	P6M5
Класс точности	A	A	A	A	AA	A
Диапазон	m 0,2–m 0,6	m 0,25–m 0,6	m 0,8–m 0,9	m 1,0–m 10,0	m 1,0–m 12,0	m 0,5–m 3,0
Страница	650	651	652	653	654	655

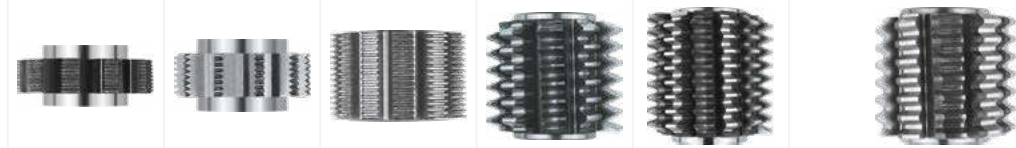

	Для шлицевых валов с прямобочным профилем	
Вид обработки		
Стандарт	ГОСТ 8027-86	ГОСТ 8027-86
Угол профиля	20°	20°
Материал	P6M5	P6M5
Класс точности	–	–
Диапазон номинального размера соединения	6x28x32–8x46x50	4x28x32–10x112x125
Страница	656	657

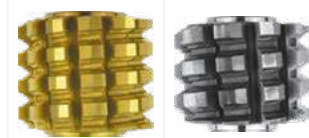

Фрезы червячные из быстрорежущей стали

Вид обработки	Цельные для нарезания зубьев звездочек к приводным роликовым и втулочным цепям	Чистовые однозаходные для зубчатых цилиндрических колес передач Новикова с 2-мя линиями зацепления
Стандарт	ГОСТ 15127-83	ГОСТ 16771-81
Диаметр ролика (втулки)	5,00–10,16	69,0–120,0
Угол профиля	–	–
Материал	P6M5	P6M5
Класс точности	–	A
Диапазон шага цепи	8,0–15,875	m 2,5–m 6,3
Страница	658	659



Фрезы червячные из твердого сплава

	Для цилиндрических зубчатых колес с эвольвентным профилем
Стандарт	ГОСТ 10331-81
Диапазон диаметров	25,0–32,0 мм
Угол профиля	20°
Материал	ВК6М
Класс точности	AA
Страница	660



Протяжки из быстрорежущей стали

	Протяжки шпоночные	
Стандарт	ГОСТ 18217-90	ГОСТ 18217-90
Материал	P6M5	P6M5
Поле допуска	Js9	D10
Диапазон ширины шпоночного паза	10,0–20,0	12,0–22,0
Страница	661	662

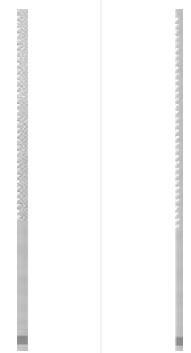

Резцы зубострогальные

	Резцы зубострогальные	
Стандарт	ГОСТ 5392-80	ГОСТ 5392-801
Материал	P6M5	P6M5
Угол профиля	20°	20°
Страница	663	664



Долбяки зуборезные из быстрорежущей стали хвостовые чистовые мелко модульные для обработки зубчатых колёс с эвольвентным профилем



Артикул	Обозначение по ГОСТ	m	Z, шт	l, мм	L, мм	КМ
1135573	2537-0221	0,80	20	6,0	60,0	B12

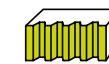

ГОСТ 10059-80

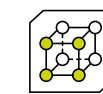

P6M5

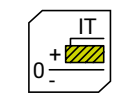

IT A



16 мм

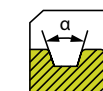

20°

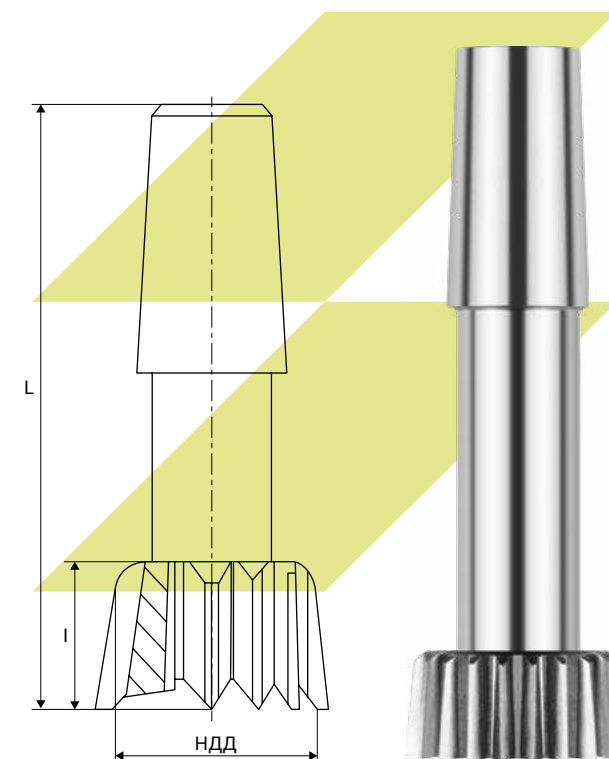

Долбяки зуборезные из быстрорежущей стали хвостовые чистовые мелко модульные для обработки зубчатых колёс с эвольвентным профилем

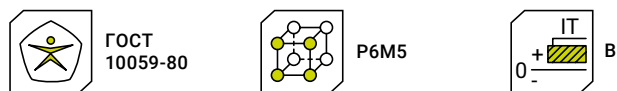

Артикул	Обозначение по ГОСТ	m	Z, шт	l, мм	L, мм	КМ
1135578	2537-0355	0,30	84	6,0	60,0	B12
1177513	2537-0356	0,30	84	6,0	60,0	B12
1135582	2537-0361	0,40	64	6,0	60,0	B12
1135586	2537-0365	0,50	50	8,0	60,0	B12
1337724	2537-0366	0,50	50	8,0	60,0	B12
1135588	2537-0371	0,60	40	8,0	60,0	B12
1135591	2537-0373	0,70	36	8,0	60,0	B12
1135592	2537-0375	0,80	32	8,0	60,0	B12
1135594	2537-0378	0,90	28	8,0	60,0	B12

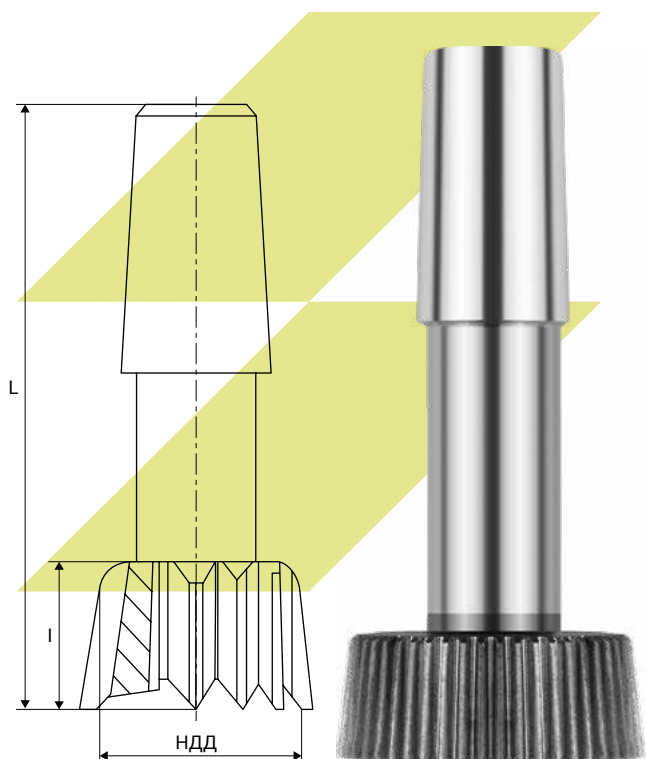

Долбяки зуборезные из быстрорежущей стали хвостовые чистовые мелко модульные для обработки зубчатых колёс с эвольвентным профилем

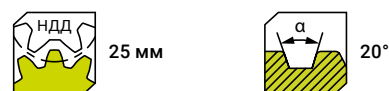
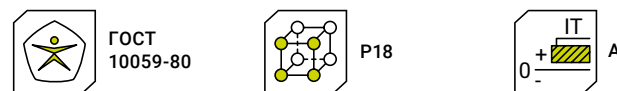
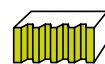

Артикул	Обозначение по ГОСТ	m	Z, шт	l, мм	L, мм	КМ
1135581	2537-0361	0,40	64	6,0	60,0	B12
1135584	2537-0365	0,50	50	8,0	60,0	B12
1135590	2537-0373	0,70	36	8,0	60,0	B12

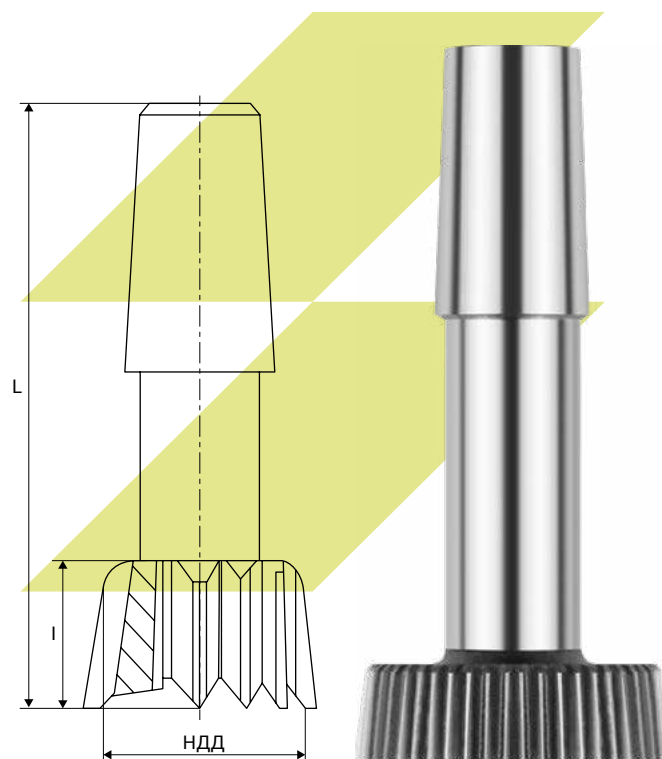

Долбяки зуборезные из быстрорежущей стали хвостовые чистовые мелко модульные для обработки зубчатых колёс с эвольвентным профилем

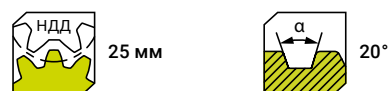
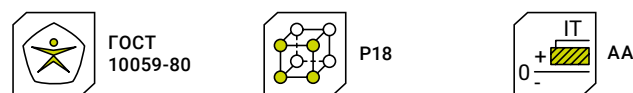

Артикул	Обозначение по ГОСТ	m	Z, шт	l, мм	L, мм	КМ
1135577	2510-0007	0,30	84	6,0	60,0	B12
1135580	2510-0009	0,40	64	6,0	60,0	B12
1135589	2510-0014	0,70	36	8,0	60,0	B12
1136091	2510-0016	0,90	28	8,0	60,0	B12

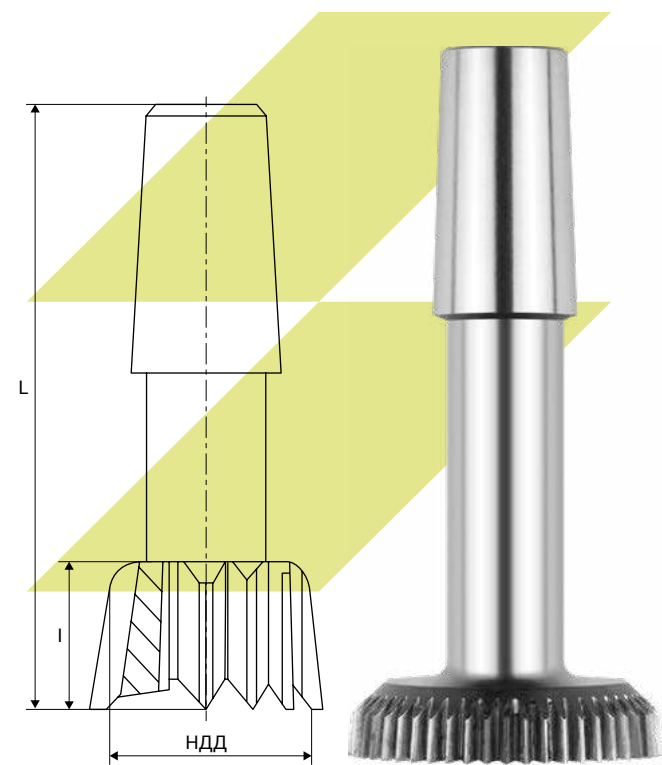

Долбяки зуборезные из быстрорежущей стали хвостовые чистовые для обработки прямозубых и косозубых цилиндрических зубчатых колёс

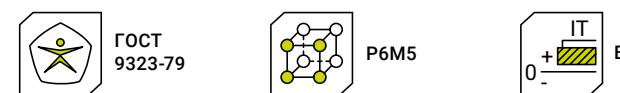

Артикул	Обозначение по ГОСТ	m	Z, шт	l, мм	L, мм	КМ
1135598	2537-0151	1,00	26	10,0	80,0	B18
1135601	2537-0153	1,25	20	10,0	80,0	B18
1135603	2537-0155	1,50	18	10,0	80,0	B18
1135606	2537-0156	1,75	14	12,0	80,0	B18
1135609	2537-0157	2,00	12	12,0	80,0	B18
1135614	2537-0158	2,25	12	12,0	80,0	B18
1135619	2537-0161	2,75	10	15,0	80,0	B18
1135620	2537-0162	3,00	9	15,0	80,0	B18

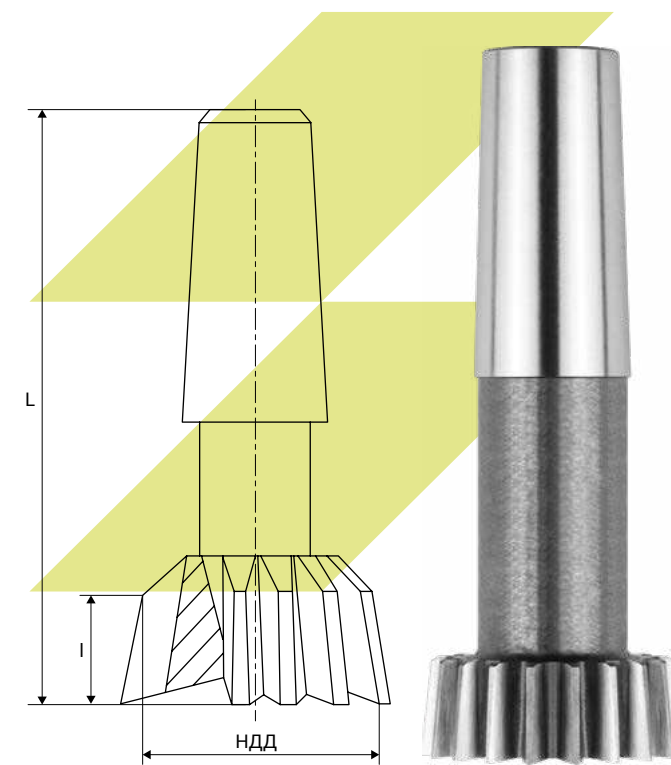

Долбяки зуборезные из быстрорежущей стали хвостовые чистовые для обработки прямозубых и косозубых цилиндрических зубчатых колёс



ГОСТ 9323-79



P6M5

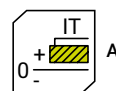

A



НДД 25 мм



α 20°

Артикул	Обозначение по ГОСТ	m	Z, шт	l, мм	L, мм	КМ
1220610	2510-0017	1,000	26	10,0	80,0	B18
1141046	2537-0152	1,125	23	10,0	80,0	B18
1141049	2537-0154	1,375	18	10,0	80,0	B18
1417067	2537-0155	1,500	18	10,0	80,0	B18
1220601	2537-0157	2,000	12	12,0	80,0	B18
1416809	2537-0159	2,500	10	15,0	80,0	B18

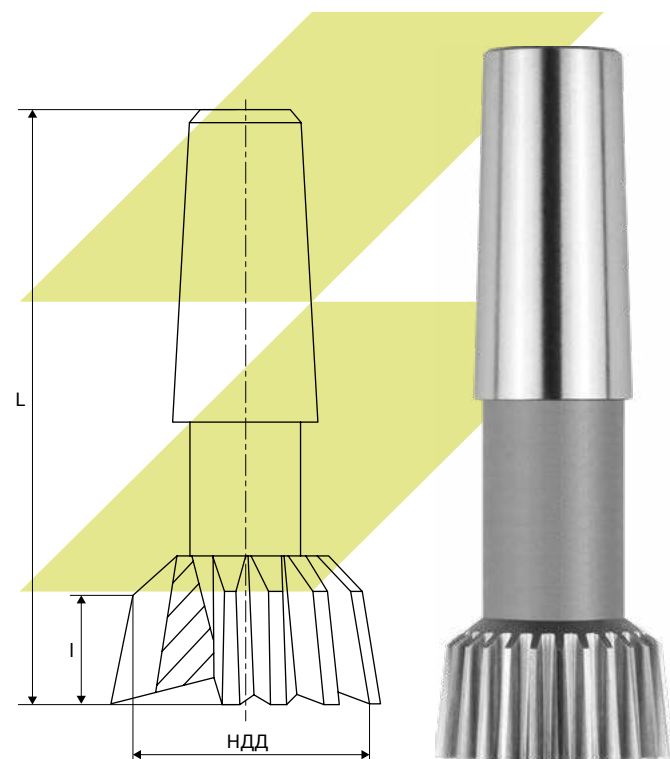

Долбяки зуборезные из быстрорежущей стали хвостовые чистовые для обработки прямозубых и косозубых цилиндрических зубчатых колёс



ГОСТ 9323-79



P6M5

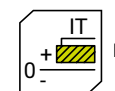

B



НДД 38 мм



α 20°

Артикул	Обозначение по ГОСТ	m	Z, шт	l, мм	L, мм	КМ
1135626	2537-0165	1,25	30	12,0	100,0	B24
1135628	2537-0167	1,50	25	12,0	100,0	B24
1135631	2538-0097	2,00	18	15,0	100,0	B24
1135632	2538-0098	2,00	18	15,0	100,0	B24
1135633	2537-0169	2,00	19	15,0	100,0	B24
1135635	2537-0171	2,25	16	15,0	100,0	B24
1135639	2537-0173	2,75	14	15,0	100,0	B24
1135643	2537-0175	3,25	12	15,0	100,0	B24
1135646	2537-0177	3,75	10	17,0	100,0	B24

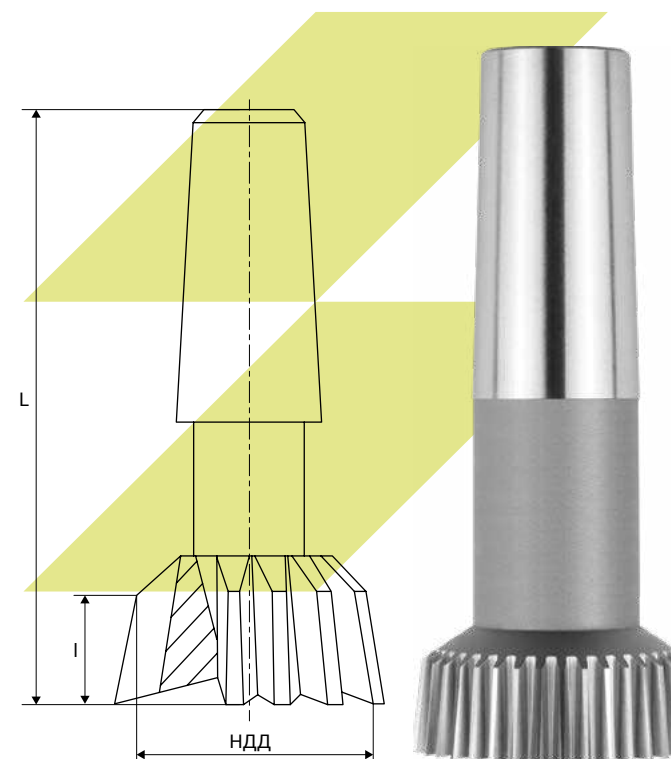

Долбяки зуборезные из быстрорежущей стали хвостовые чистовые для обработки прямозубых и косозубых цилиндрических зубчатых колёс

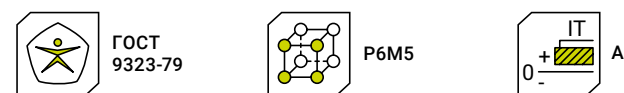

Артикул	Обозначение по ГОСТ	m	Z, шт	l, мм	L, мм	КМ
1220602	2537-0163	1,000	38	12,0	100,0	B24
1141052	2537-0164	1,125	34	12,0	100,0	B24
1141054	2537-0166	1,375	28	12,0	100,0	B24
1220603	2537-0167	1,500	25	12,0	100,0	B24
1416811	2537-0169	2,000	19	15,0	100,0	B24
1416813	2537-0172	2,500	15	15,0	100,0	B24
1141058	2537-0173	2,750	14	15,0	100,0	B24
1416815	2537-0174	3,000	12	15,0	100,0	B24
1141060	2537-0176	3,500	11	15,0	100,0	B24
1416817	2537-0178	4,000	10	17,0	100,0	B24

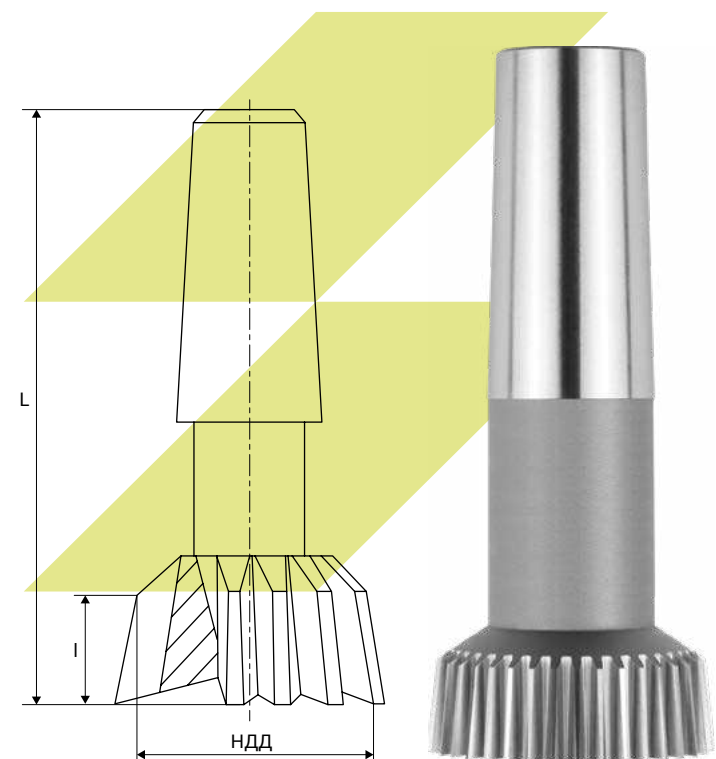

Долбяки зуборезные из быстрорежущей стали хвостовые чистовые для обработки зубьев валов и отверстий шлицевых соединений с эвольвентным профилем

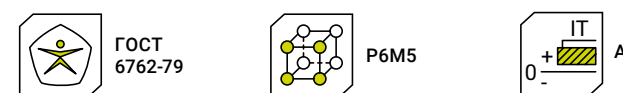

Артикул	Обозначение по ГОСТ	m	Z, шт	l, мм	L, мм	КМ
1477658	2540-0063	0,80	16	10,0	60,0	B12
1416803	2540-0064	1,00	12	10,0	60,0	B12
1477659	2540-0065	1,25	10	10,0	60,0	B12

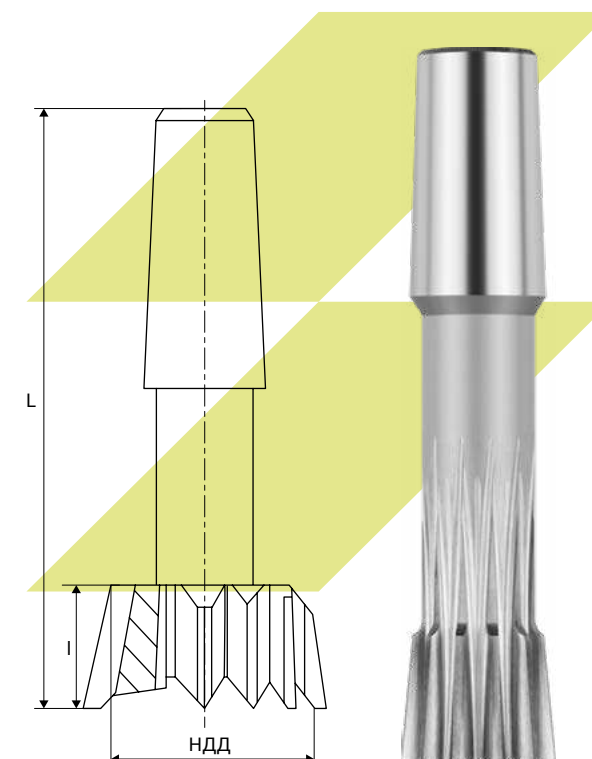

Долбяки зуборезные из быстрорежущей стали хвостовые чистовые для обработки зубьев валов и отверстий шлицевых соединений с эвольвентным профилем

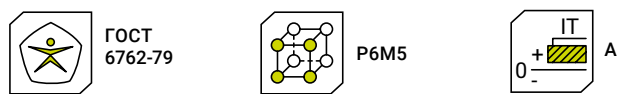

Артикул	Обозначение по ГОСТ	m	Z, шт	l, мм	L, мм	КМ
1477662	2540-0069	0,80	20	10,0	60,0	B12
1416805	2540-0071	1,00	16	10,0	60,0	B12
1477663	2540-0072	1,25	13	10,0	60,0	B12
1416806	2540-0073	1,50	10	10,0	60,0	B12
1591718	2540-0074	2,00	9	12,0	60,0	B12

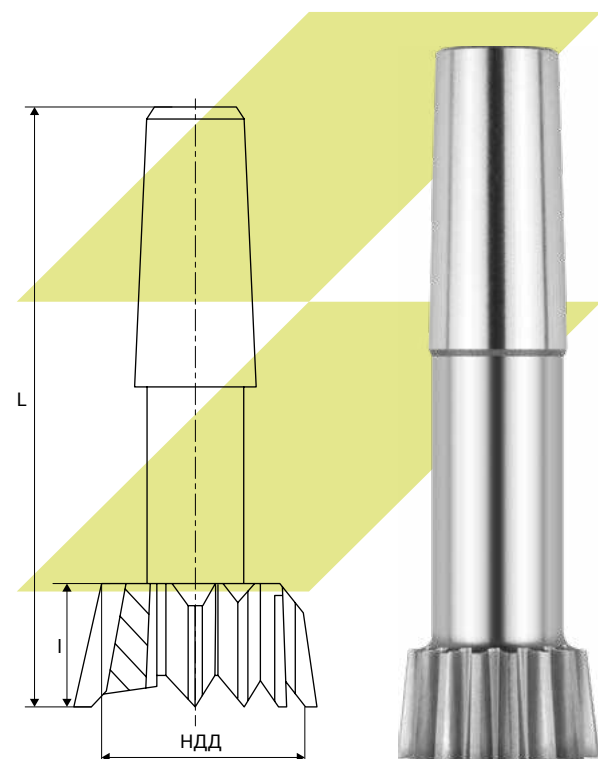

Долбяки зуборезные из быстрорежущей стали хвостовые чистовые для обработки зубьев валов и отверстий шлицевых соединений с эвольвентным профилем

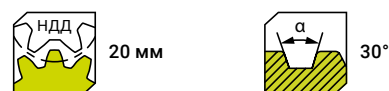
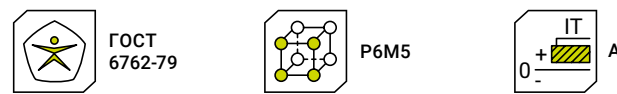
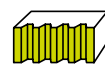

Артикул	Обозначение по ГОСТ	m	Z, шт	l, мм	L, мм	КМ
1264177	2540-0075	0,50	40	10,0	76,0	B12
1477664	2540-0077	0,80	26	10,0	76,0	B12
1265285	2540-0078	1,00	20	10,0	76,0	B18
1477665	2540-0079	1,25	16	10,0	76,0	B18
1416807	2540-0081	1,50	14	10,0	76,0	B18

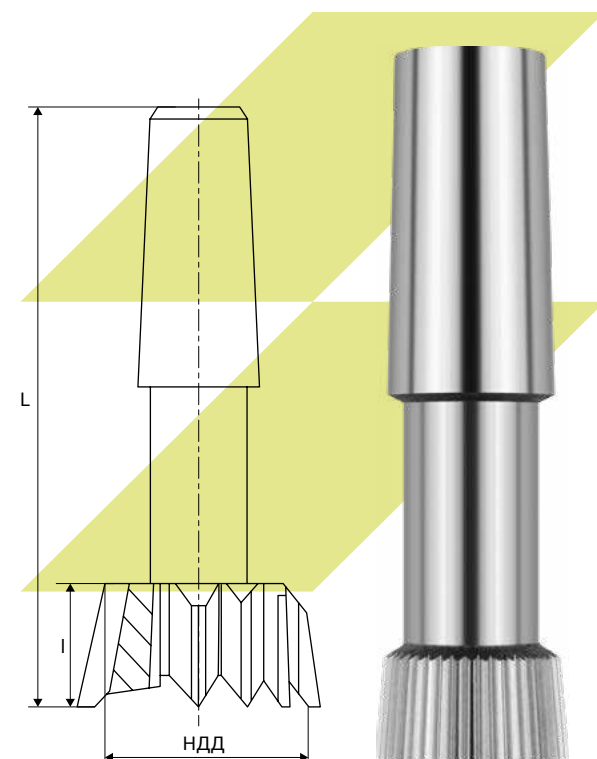

Долбяки зуборезные из быстрорежущей стали хвостовые чистовые для обработки зубьев валов и отверстий шлицевых соединений с эвольвентным профилем

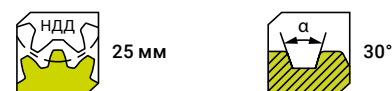
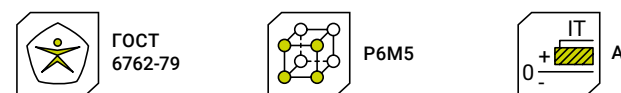

Артикул	Обозначение по ГОСТ	m	Z, шт	l, мм	L, мм	КМ
1424715	2540-0085	0,80	30	10,0	76,0	B18
1135599	2540-0086	1,00	26	10,0	76,0	B18
1265283	2540-0087	1,25	20	10,0	76,0	B18
1416808	2540-0088	1,50	18	10,0	76,0	B18
1265282	2540-0089	2,00	13	12,0	78,0	B18
1416810	2540-0091	2,50	10	12,0	78,0	B18
1220606	2540-0092	3,00	9	12,0	78,0	B18
1477667	2540-0093	3,50	9	15,0	81,0	B18

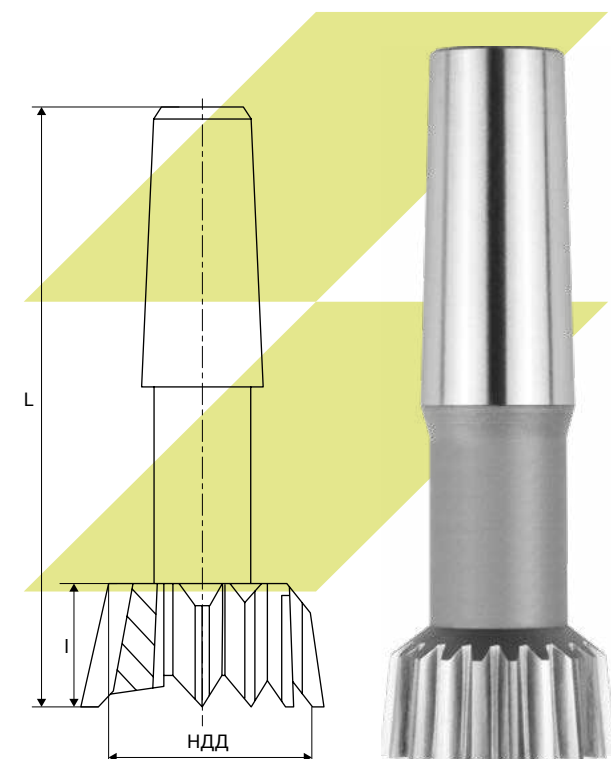

Долбяки зуборезные из быстрорежущей стали хвостовые чистовые для обработки зубьев валов и отверстий шлицевых соединений с эвольвентным профилем

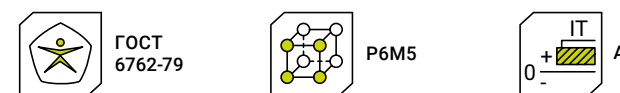

Артикул	Обозначение по ГОСТ	m	Z, шт	l, мм	L, мм	КМ
1265284	2540-0082	2,00	10	12,0	78,0	B24
1477668	2540-0094	0,50	76	12,0	97,0	B24
1477669	2540-0096	0,80	48	12,0	97,0	B24
1337726	2540-0097	1,00	38	12,0	97,0	B24
1416812	2540-0101	2,00	19	15,0	100,0	B24
1416814	2540-0102	2,50	15	15,0	100,0	B24
1416816	2540-0103	3,00	12	15,0	100,0	B24
1477670	2540-0104	3,50	11	15,0	100,0	B24
1220607	2540-0105	4,00	10	17,0	102,0	B24
1416818	2540-0106	5,00	9	17,0	102,0	B24

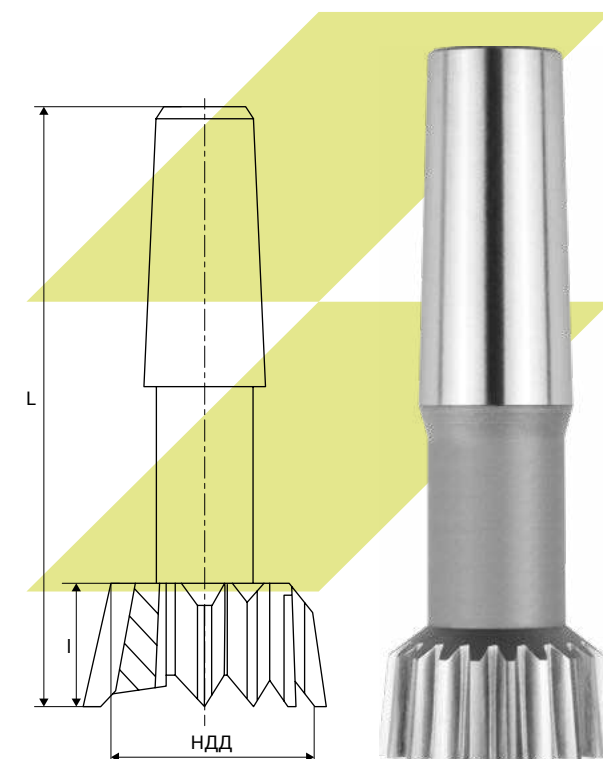

Долбяки зуборезные из быстрорежущей стали дисковые чистовые мелко модульные для обработки зубчатых колёс с эвольвентным профилем



Артикул	Обозначение по ГОСТ	m	Z, шт	d, мм	L, мм
1137932	2530-0326	0,70	56	20,0	12,0
1137933	2530-0327	0,80	50	20,0	12,0
1137935	2530-0328	0,90	44	20,0	12,0

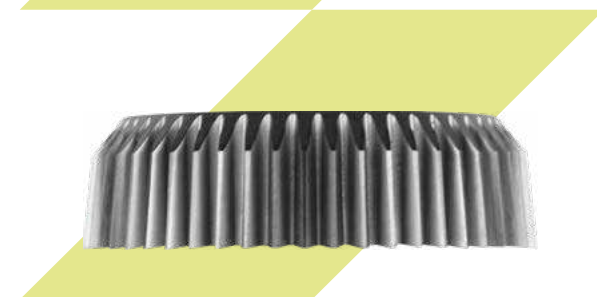
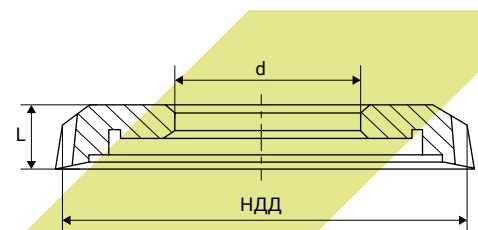
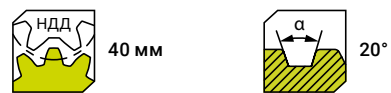
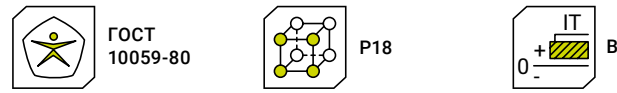

Долбяки зуборезные из быстрорежущей стали дисковые чистовые мелко модульные для обработки зубчатых колёс с эвольвентным профилем



Артикул	Обозначение по ГОСТ	m	Z, шт	d, мм	L, мм
1137937	—	0,3	214	31,75	11,0
1137938	2530-0337	0,4	160	31,75	11,0
1137941	2530-0342	0,6	108	31,75	11,0
1137943	2530-0343	0,7	90	31,75	12,0
1476932	2530-0344	0,8	80	31,75	12,0

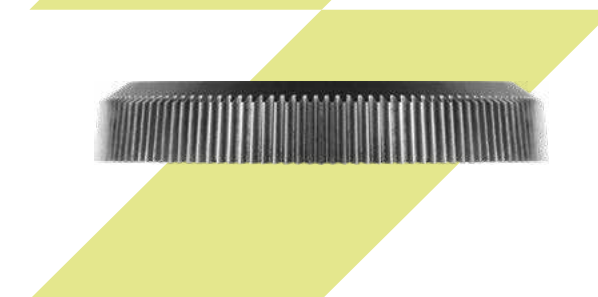
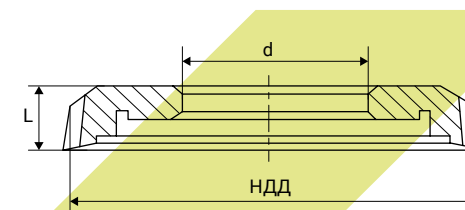
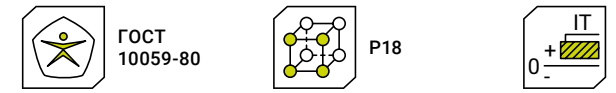

Долбяки зуборезные из быстрорежущей стали дисковые чистовые для обработки прямозубых и косозубых цилиндрических зубчатых колёс

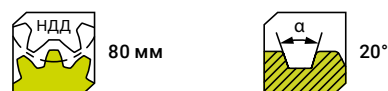
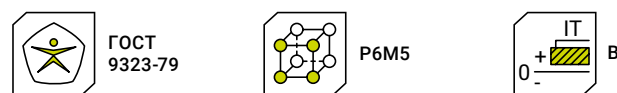
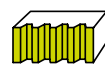

Артикул	Обозначение по ГОСТ	m	Z, шт	d, мм	L, мм
1137969	2530-0155	1,25	60	31,75	12,0
1276354	2530-0162	1,75	43	31,75	15,0
1335851	2530-0164	2,00	38	31,75	15,0
1137984	2530-0168	2,50	30	31,75	15,0
1137986	2530-0171	2,75	28	31,75	17,0
1137996	2530-0179	3,75	20	31,75	17,0
1138005	2530-0186	4,50	17	31,75	17,0

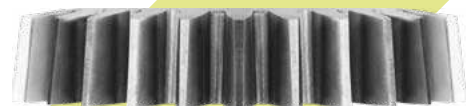
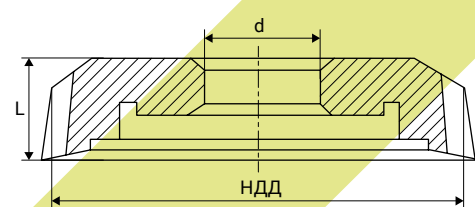

Долбяки зуборезные из быстрорежущей стали дисковые чистовые для обработки прямозубых и косозубых цилиндрических зубчатых колёс

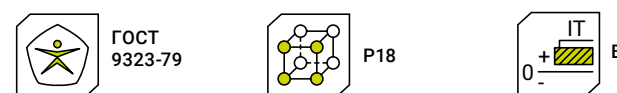

Артикул	Обозначение по ГОСТ	m	Z, шт	d, мм	L, мм
1137968	2530-0155	1,25	60	31,75	12,0
1137973	2530-0159	1,50	50	31,75	12,0
1137983	2530-0168	2,50	30	31,75	15,0
1220273	2530-0171	2,75	28	31,75	17,0
1137994	2530-0177	3,50	22	31,75	17,0
1137995	2530-0179	3,75	20	31,75	17,0
1138004	2530-0186	4,50	17	31,75	17,0

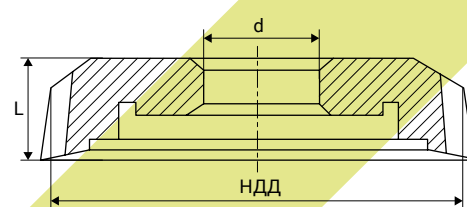

Долбяки зуборезные из быстрорежущей стали дисковые чистовые для обработки прямозубых и косозубых цилиндрических зубчатых колёс

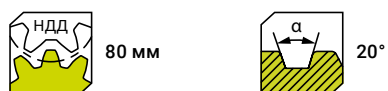
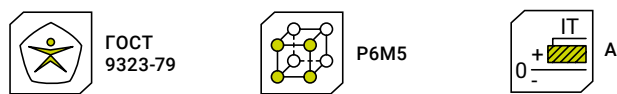

Артикул	Обозначение по ГОСТ	m	Z, шт	d, мм	L, мм
1236350	2530-0155	1,25	60	31,75	12,0
1137971	2530-0159	1,50	50	31,75	12,0
1137977	2530-0164	2,00	38	31,75	15,0
1220274	2530-0166	2,25	34	31,75	15,0
1137982	2530-0168	2,50	30	31,75	15,0
1137985	2530-0171	2,75	28	31,75	17,0
1137993	2530-0177	3,50	22	31,75	17,0
1137998	2530-0182	4,00	19	31,75	17,0
1276355	2530-0184	4,25	18	31,75	17,0
1138003	2530-0186	4,50	17	31,75	17,0

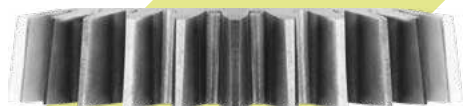
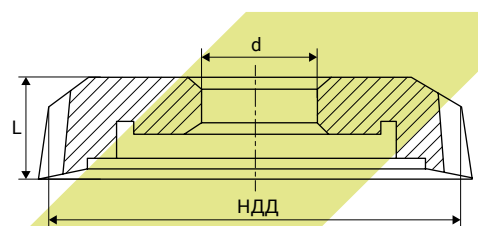

Долбяки зуборезные из быстрорежущей стали дисковые чистовые для обработки прямозубых и косозубых цилиндрических зубчатых колёс

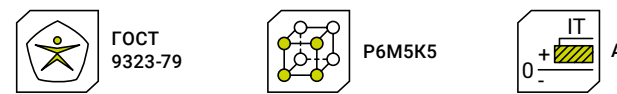

Артикул	Обозначение по ГОСТ	m	Z, шт	d, мм	L, мм
1533005	2530-0155	1,25	60	31,75	12,0
1137978	2530-0164	2,00	38	31,75	15,0
1220272	2530-0166	2,25	34	31,75	15,0

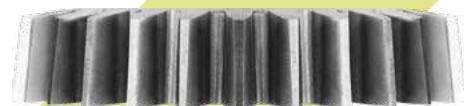
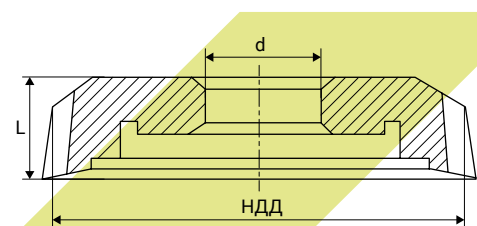

Обработка зубчатых и шлицевых соединений

Обработка зубчатых и шлицевых соединений

Долбяки зуборезные из быстрорежущей стали дисковые чистовые для обработки прямозубых и косозубых цилиндрических зубчатых колёс

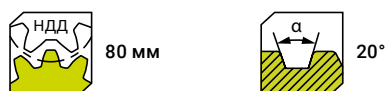
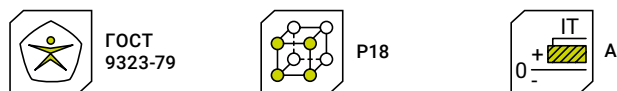

Артикул	Обозначение по ГОСТ	m	Z, шт	d, мм	L, мм
1137967	2530-0155	1,25	60	31,75	12,0
1137970	2530-0159	1,50	50	31,75	12,0
1137976	2530-0164	2,00	38	31,75	15,0
1137979	2530-0166	2,25	34	31,75	15,0
1137981	2530-0168	2,50	30	31,75	15,0
1137992	2530-0177	3,50	22	31,75	17,0
1137997	2530-0182	4,00	19	31,75	17,0
1138000	2530-0184	4,25	18	31,75	17,0
1261446	2530-0188	5,00	16	31,75	17,0

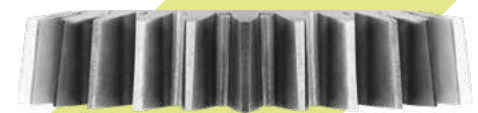
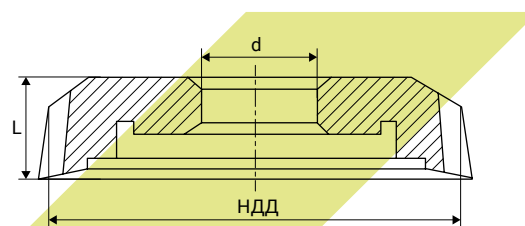

Долбяки зуборезные из быстрорежущей стали дисковые чистовые для обработки прямозубых и косозубых цилиндрических зубчатых колёс

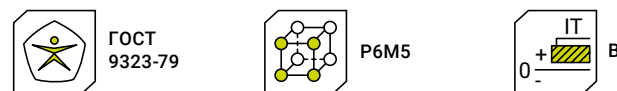

Артикул	Обозначение по ГОСТ	m	Z, шт	d, мм	L, мм
1476934	2530-0195	1,25	80	44,45	17,0
1138019	2530-0199	1,50	68	44,45	17,0
1138024	2530-0202	1,75	58	44,45	17,0
1138044	2530-0211	2,75	36	44,45	20,0
1138050	2530-0213	3,00	34	44,45	20,0
1138053	2530-0215	3,25	31	44,45	20,0
1177642	2530-0217	3,50	28	44,45	20,0
1138061	2530-0219	3,75	27	44,45	20,0
1138065	2530-0222	4,00	25	44,45	20,0
1138074	2530-0226	4,50	22	44,45	20,0
1138083	2530-0228	5,00	20	44,45	20,0

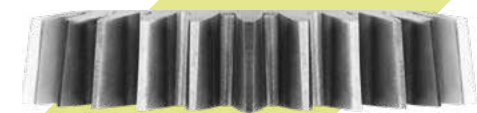
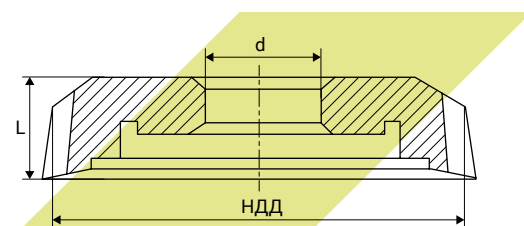

Обработка зубчатых и шлицевых соединений

Обработка зубчатых и шлицевых соединений

Долбяки зуборезные из быстрорежущей стали дисковые чистовые для обработки прямозубых и косозубых цилиндрических зубчатых колёс

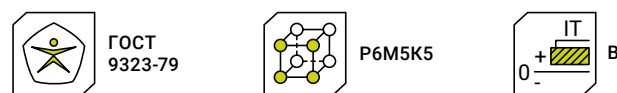

Артикул	Обозначение по ГОСТ	m	Z, шт	d, мм	L, мм
1138011	2530-0191	1,000	100	44,45	17,0
1138012	2530-0193	1,125	90	44,45	17,0
1138020	2530-0199	1,500	68	44,45	17,0
1276356	2530-0202	1,750	58	44,45	17,0
1138040	2530-0208	2,500	40	44,45	20,0
1138045	2530-0211	2,750	36	44,45	20,0
1138051	2530-0213	3,000	34	44,45	20,0
1258077	2530-0217	3,500	28	44,45	20,0
1138066	2530-0222	4,000	25	44,45	20,0
1138070	2530-0224	4,250	24	44,45	20,0
1138075	2530-0226	4,500	22	44,45	20,0
1138084	2530-0228	5,000	20	44,45	20,0

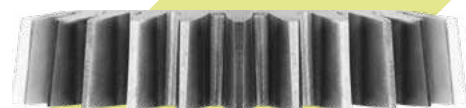
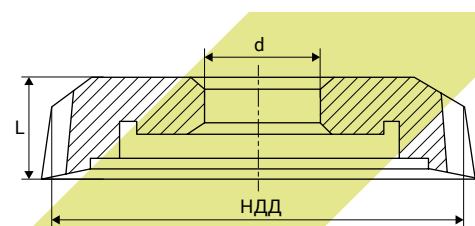

Долбяки зуборезные из быстрорежущей стали дисковые чистовые для обработки прямозубых и косозубых цилиндрических зубчатых колёс

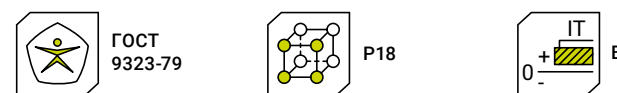

Артикул	Обозначение по ГОСТ	m	Z, шт	d, мм	L, мм
1138015	2530-0195	1,25	80	44,45	17,0
1138018	2530-0199	1,50	68	44,45	17,0
1138023	2530-0202	1,75	58	44,45	17,0
1138029	2530-0204	2,00	50	44,45	20,0
1138038	2530-0208	2,50	40	44,45	20,0
1138043	2530-0211	2,75	36	44,45	20,0
1138049	2530-0213	3,00	34	44,45	20,0
1138082	2530-0228	5,00	20	44,45	20,0
1138093	2530-0235	6,50	16	44,45	22,0

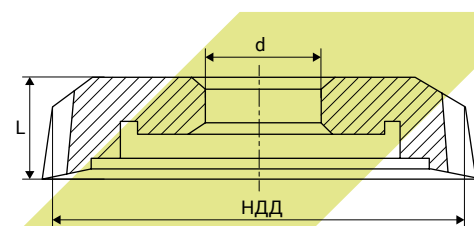

Обработка зубчатых и шлицевых соединений

Обработка зубчатых и шлицевых соединений

Долбяки зуборезные из быстрорежущей стали дисковые чистовые для обработки прямозубых и косозубых цилиндрических зубчатых колёс

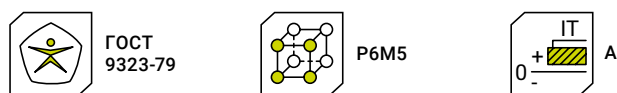

Артикул	Обозначение по ГОСТ	m	Z, шт	d, мм	L, мм
1273098	2530-0191	1,00	100	44,45	17,0
1138014	2530-0195	1,25	80	44,45	17,0
1138017	2530-0199	1,50	68	44,45	17,0
1138022	2530-0202	1,75	58	44,45	17,0
1138032	2530-0206	2,25	45	44,45	20,0
1138036	2530-0208	2,50	40	44,45	20,0
1138042	2530-0211	2,75	36	44,45	20,0
1138047	2530-0213	3,00	34	44,45	20,0
1138052	2530-0215	3,25	31	44,45	20,0
1138054	2530-0217	3,50	28	44,45	20,0
1138059	2530-0219	3,75	27	44,45	20,0
1138064	2530-0222	4,00	25	44,45	20,0
1138069	2530-0224	4,25	24	44,45	20,0
1138073	2530-0226	4,50	22	44,45	20,0

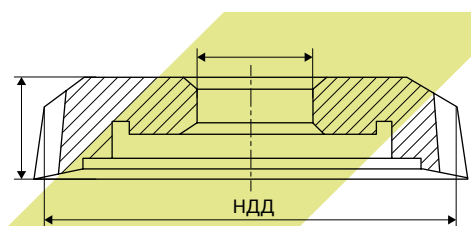

Долбяки зуборезные из быстрорежущей стали дисковые чистовые для обработки прямозубых и косозубых цилиндрических зубчатых колёс

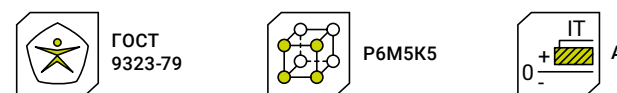

Артикул	Обозначение по ГОСТ	m	Z, шт	d, мм	L, мм
1138028	2530-0204	2,00	50	44,45	20,0
1138037	2530-0208	2,50	40	44,45	20,0
1138055	2530-0217	3,50	28	44,45	20,0
1138060	2530-0219	3,75	27	44,45	20,0
1335856	2530-0222	4,00	25	44,45	20,0

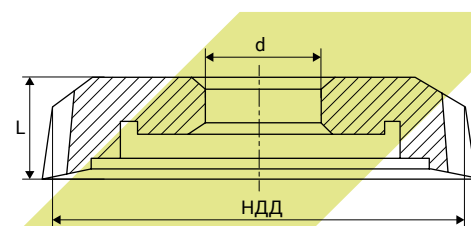

Обработка зубчатых и шлицевых соединений

Обработка зубчатых и шлицевых соединений

Долбяки зуборезные из быстрорежущей стали дисковые чистовые для обработки прямозубых и косозубых цилиндрических зубчатых колёс



ГОСТ 9323-79



P18

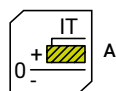

A



100 мм



20°

Артикул	Обозначение по ГОСТ	m	Z, шт	d, мм	L, мм
1138013	2530-0195	1,25	80	44,45	17,0
1138016	2530-0199	1,50	68	44,45	17,0
1138021	2530-0202	1,75	58	44,45	17,0
1138026	2530-0204	2,00	50	44,45	20,0
1138041	2530-0211	2,75	36	44,45	20,0
1258076	2530-0217	3,50	28	44,45	20,0
1138063	2530-0222	4,00	25	44,45	20,0
1138068	2530-0224	4,25	24	44,45	20,0
1138072	2530-0226	4,50	22	44,45	20,0
1138079	2530-0228	5,00	20	44,45	20,0
1138089	2530-0233	6,00	17	44,45	22,0
1138092	2530-0235	6,50	16	44,45	22,0

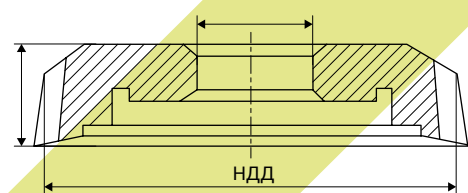

Долбяки зуборезные из быстрорежущей стали дисковые чистовые для обработки прямозубых и косозубых цилиндрических зубчатых колёс

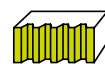

ГОСТ 9323-79



P6M5

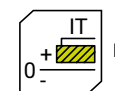

B



125 мм



20°

Артикул	Обозначение по ГОСТ	m	Z, шт	d, мм	L, мм
1138100	2530-0264	5,0	25	44,45	28,0
1138101	2530-0268	6,0	21	44,45	28,0
1138102	2530-0268	6,0	21	44,45	28,0
1138103	2530-0271	6,5	19	44,45	28,0
1138109	2530-0277	9,0	14	44,45	28,0
1138110	2530-0277	9,0	14	44,45	28,0

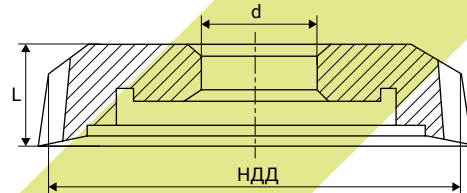

Долбяки зуборезные из быстрорежущей стали дисковые чистовые для обработки прямозубых и косозубых цилиндрических зубчатых колёс



Артикул	Обозначение по ГОСТ	m	Z, шт	d, мм	L, мм
1336274	2530-0282	6,0	27	88,90	30,0
1336275	2530-0282	6,0	27	88,90	30,0
1150810	2530-0291	9,0	18	88,90	32,0

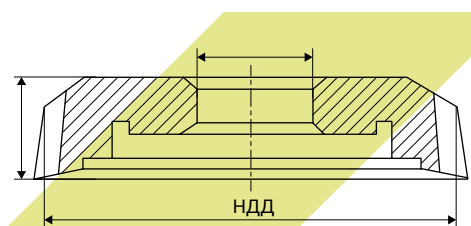
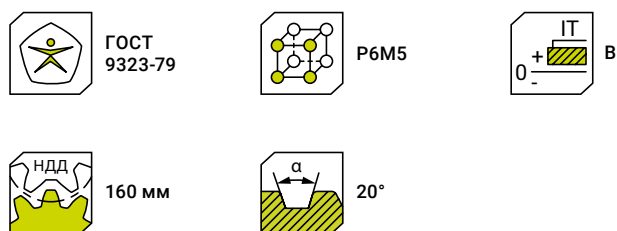

Долбяки зуборезные из быстрорежущей стали дисковые чистовые для обработки зубьев валов и отверстий шлицевых соединений с эвольвентным профилем

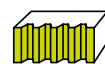

Артикул	Обозначение по ГОСТ	m	Z, шт	d, мм	L, мм
1441794	2540-0004	1,00	76	31,75	12,0
1441795	2540-0006	1,50	50	31,75	12,0
1137963	2540-0013	5,00	15	31,75	20,0

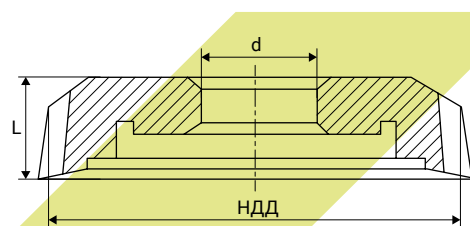
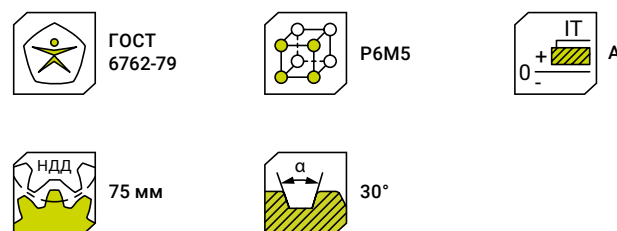

Обработка зубчатых и шлицевых соединений

Обработка зубчатых и шлицевых соединений

Долбяки зуборезные из быстрорежущей стали дисковые чистовые для обработки зубьев валов и отверстий шлицевых соединений с эвольвентным профилем



Артикул	Обозначение по ГОСТ	m	Z, шт	L, мм	d, мм
1425805	—	2,00	50	20,0	44,45
1138057	2540-0016	3,50	28	20,0	44,45

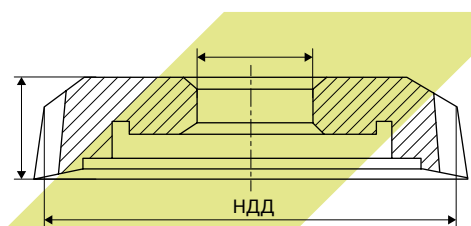
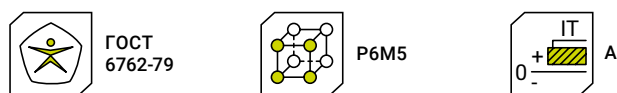

Долбяки зуборезные из быстрорежущей стали чашечные чистовые для обработки прямозубых и косозубых цилиндрических зубчатых колёс



Артикул	Обозначение по ГОСТ	m	Z, шт	d, мм	l, мм	L, мм
1135998	2536-0105	1,50	34	20,0	12,0	25,0
1136002	2536-0107	2,00	25	20,0	15,0	25,0
1136008	2536-0111	2,75	18	20,0	15,0	25,0

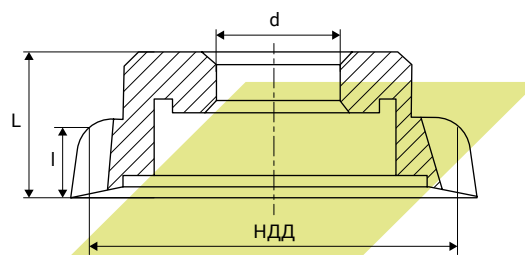
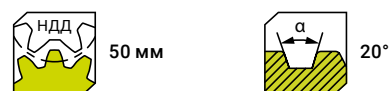
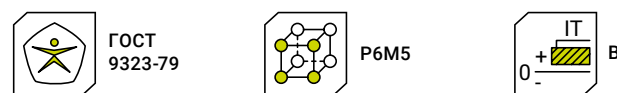
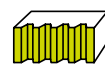

Долбяки зуборезные из быстрорежущей стали чашечные чистовые для обработки прямозубых и косозубых цилиндрических зубчатых колёс

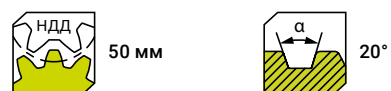
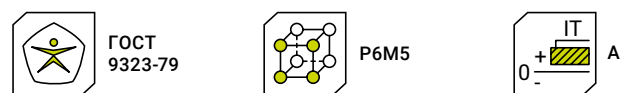

Артикул	Обозначение по ГОСТ	m	Z, шт	d, мм	l, мм	L, мм
1220604	2536-0101	1,00	50	20,0	12,0	25,0
1477675	2536-0105	1,50	34	20,0	12,0	25,0
1136001	2536-0107	2,00	25	20,0	15,0	25,0
1591720	2536-0109	2,50	20	15,0	15,0	25,0
1336342	2536-0111	2,75	18	20,0	15,0	25,0
1477678	2536-0112	3,00	17	20,0	17,0	25,0
1591721	2536-0114	3,50	14	17,0	17,0	25,0

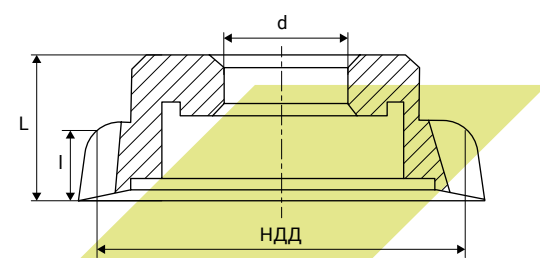

Долбяки зуборезные из быстрорежущей стали чашечные чистовые для обработки прямозубых и косозубых цилиндрических зубчатых колёс

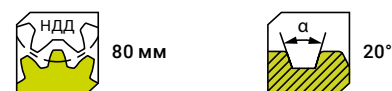
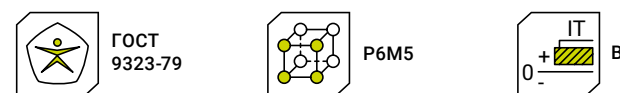

Артикул	Обозначение по ГОСТ	m	Z, шт	d, мм	l, мм	L, мм
1220276	2536-0131	2,25	34	31,75	15,0	30,0
1136109	2536-0135	2,75	28	31,75	17,0	30,0
1136041	2536-0137	3,00	25	31,75	17,0	30,0
1136043	2536-0142	3,50	22	31,75	17,0	30,0

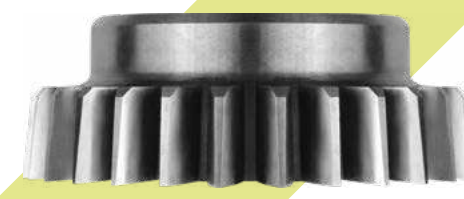
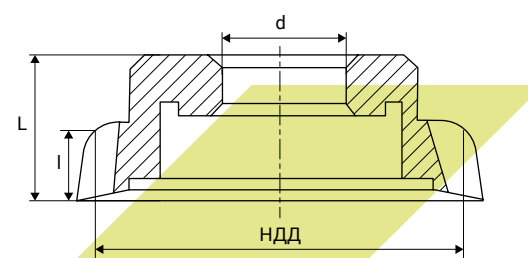

Долбяки зуборезные из быстрорежущей стали чашечные чистовые для обработки прямозубых и косозубых цилиндрических зубчатых колёс

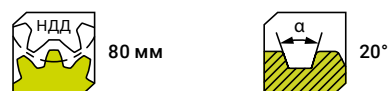
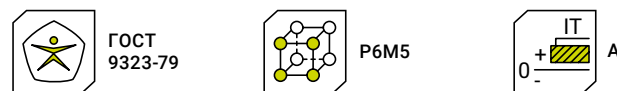
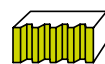

Артикул	Обозначение по ГОСТ	m	Z, шт	d, мм	l, мм	L, мм
1220605	2536-0124	1,50	50	31,75	12,0	28,0
1591724	2536-0126	1,75	43	15,00	15,0	30,0
1136036	2536-0131	2,25	34	31,75	15,0	30,0
1220277	2536-0135	2,75	28	31,75	17,0	30,0
1591725	2536-1373	3,00	25	31,75	17,0	30,0

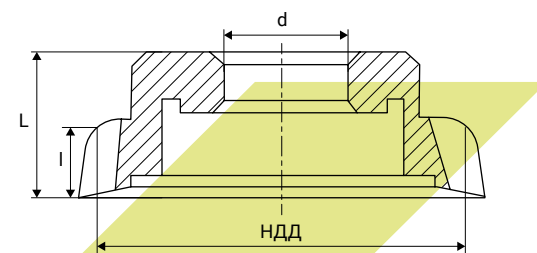

Долбяки зуборезные из быстрорежущей стали чашечные чистовые для обработки прямозубых и косозубых цилиндрических зубчатых колёс

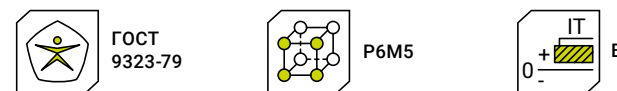

Артикул	Обозначение по ГОСТ	m	Z, шт	d, мм	l, мм	L, мм
1136047	2536-0144	1,00	100	44,45	17,0	30,0
1136052	2536-0153	1,50	68	44,45	17,0	30,0
1136053	2536-0155	1,75	58	44,45	17,0	30,0
1258075	2536-0159	2,25	45	44,45	20,0	32,0
1136062	2536-0162	2,50	40	44,45	20,0	32,0
1137891	2536-0164	2,75	36	44,45	20,0	32,0
1136068	2536-0168	3,25	31	44,45	20,0	32,0
1416898	2536-0175	4,00	25	44,45	20,0	32,0
1136078	2536-0179	4,50	22	44,45	20,0	32,0

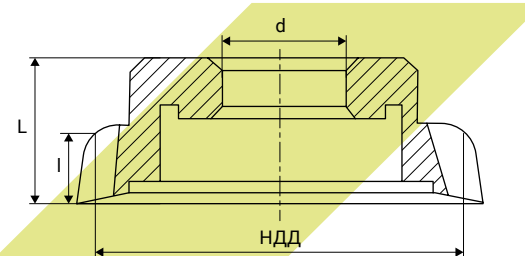

Долбяки зуборезные из быстрорежущей стали чашечные чистовые для обработки прямозубых и косозубых цилиндрических зубчатых колёс

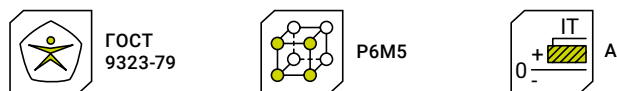

Артикул	Обозначение по ГОСТ	m	Z, шт	d, мм	l, мм	L, мм
1136046	2536-0144	1,00	100	44,45	17,0	30,0
1136049	2536-0148	1,25	80	44,45	17,0	30,0
1136050	2536-0153	1,50	68	44,45	17,0	30,0
1136108	2536-0159	2,25	45	44,45	20,0	32,0
1136060	2536-0162	2,50	40	44,45	20,0	32,0
1136107	2536-0164	2,75	36	44,45	20,0	32,0
1136064	2536-0166	3,00	34	44,45	20,0	32,0
1136067	2536-0168	3,25	31	44,45	20,0	32,0
1136070	2536-0171	3,50	28	44,45	20,0	32,0
1136072	2536-0175	4,00	25	44,45	20,0	32,0
1258078	2536-0177	4,25	24	44,45	20,0	32,0
1136077	2536-0179	4,50	22	44,45	20,0	32,0

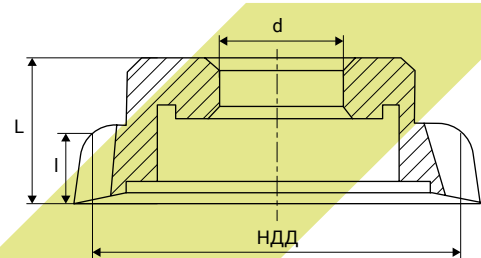

Долбяки зуборезные из быстрорежущей стали чашечные чистовые для обработки прямозубых и косозубых цилиндрических зубчатых колёс

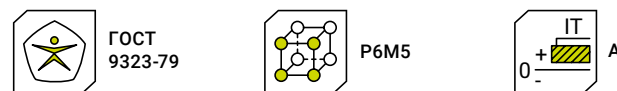
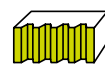

Артикул	Обозначение по ГОСТ	m	Z, шт	d, мм	l, мм	L, мм
1138140	2536-0191	5,0	25	44,45	26,0	38,0

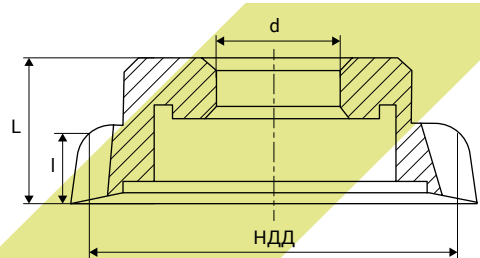

Долбяки зуборезные из быстрорежущей стали чашечные чистовые для обработки зубьев валов и отверстий шлицевых соединений с эвольвентным профилем

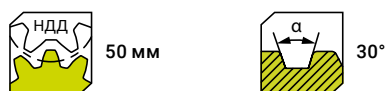
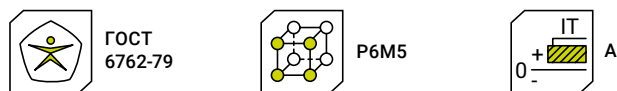

Артикул	Обозначение по ГОСТ	m	Z, шт	d, мм	l, мм	L, мм
1477671	2540-0027	0,50	100	20,00	12,0	25,0
1477672	2540-0029	0,80	62	20,00	12,0	25,0
1477673	2540-0031	1,00	50	20,00	12,0	25,0
1477674	2540-0032	1,25	40	20,00	12,0	25,0
1477676	2540-0033	1,50	34	20,00	12,0	25,0
1220608	2540-0034	2,00	25	20,00	15,0	25,0
1477677	2540-0035	2,50	20	20,00	15,0	25,0
1220609	2540-0036	3,00	17	20,00	17,0	25,0
1591722	2540-0037	3,50	14	17,00	17,0	25,0

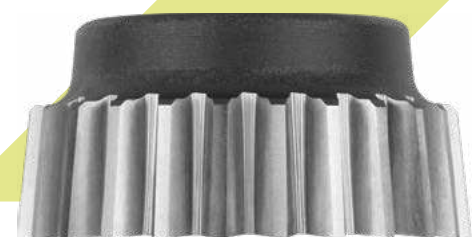
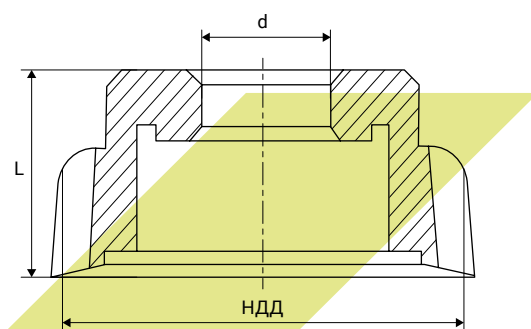

Долбяки зуборезные из быстрорежущей стали чашечные чистовые для обработки зубьев валов и отверстий шлицевых соединений с эвольвентным профилем

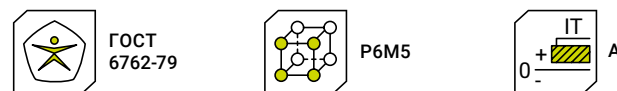
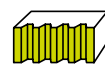

Артикул	Обозначение по ГОСТ	m	Z, шт	d, мм	l, мм	L, мм
1323785	2540-0049	3,50	28	44,45	20,0	32,0
1477680	2540-0051	4,00	25	44,45	20,0	32,0
1477681	2540-0052	5,00	20	44,45	20,0	32,0
1591730	2540-0056	10,00	10	44,45	26,0	38,0

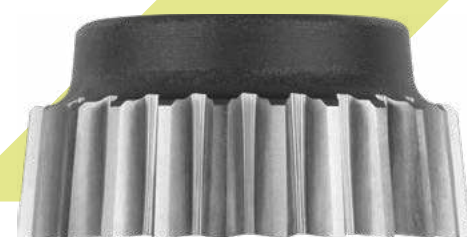
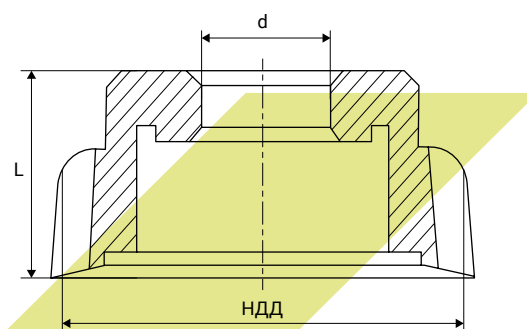

Фрезы дисковые зуборезные мелко модульные, комплект из 8 штук

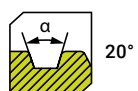
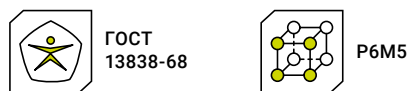

Артикул	Обозначение по ГОСТ	m	D, мм	d, мм	l, мм	Z, шт
109324	2500-0041	0,3	32,0	13,0	3,2	12
109348	2500-0043	0,4	32,0	13,0	3,2	12
109361	2500-0045	0,5	32,0	13,0	3,2	12
109379	2500-0047	0,6	32,0	13,0	3,2	12
109394	2500-0048	0,7	32,0	13,0	3,2	12
109427	2500-0050	0,9	32,0	13,0	3,2	12

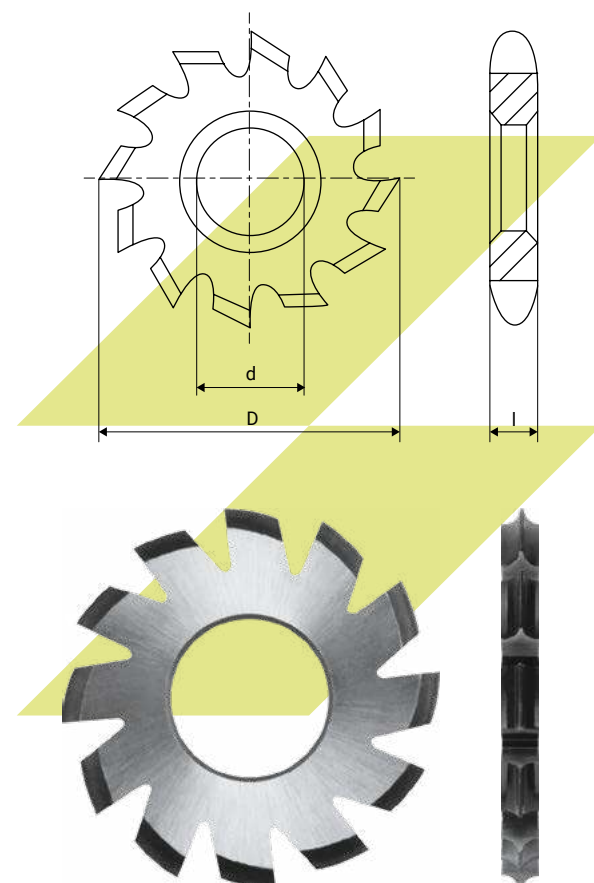

Фрезы дисковые зуборезные модульные, комплект из 8 штук

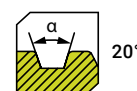
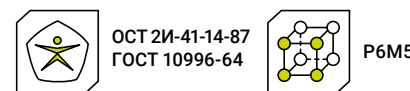

Артикул	m	D, мм	d, мм	Z, шт
1289486	1,00	50,0	19,0	14
1289487	1,25	50,0	19,0	14
1289488	1,50	55,0	22,0	14
109484	1,75	55,0	22,0	14
1289495	2,00	63,0	22,0	12
109530	2,25	63,0	22,0	12
1289496	2,50	70,0	22,0	12
1289497	2,75	70,0	22,0	12
1289498	3,00	80,0	27,0	12
109601	3,25	80,0	27,0	12
109624	3,50	80,0	27,0	12
109654	3,75	80,0	27,0	12
1425320	4,00	90,0	27,0	12
109695	4,25	90,0	27,0	12
109719	4,50	90,0	27,0	12
1220087	5,00	100,0	32,0	12
109756	6,00	110,0	32,0	10
109776	6,50	110,0	32,0	10
109794	7,00	110,0	32,0	10
109823	8,00	125,0	32,0	10
109845	9,00	115,0	32,0	10
115747	11,00	140,0	40,0	10
115748	12,00	160,0	40,0	10

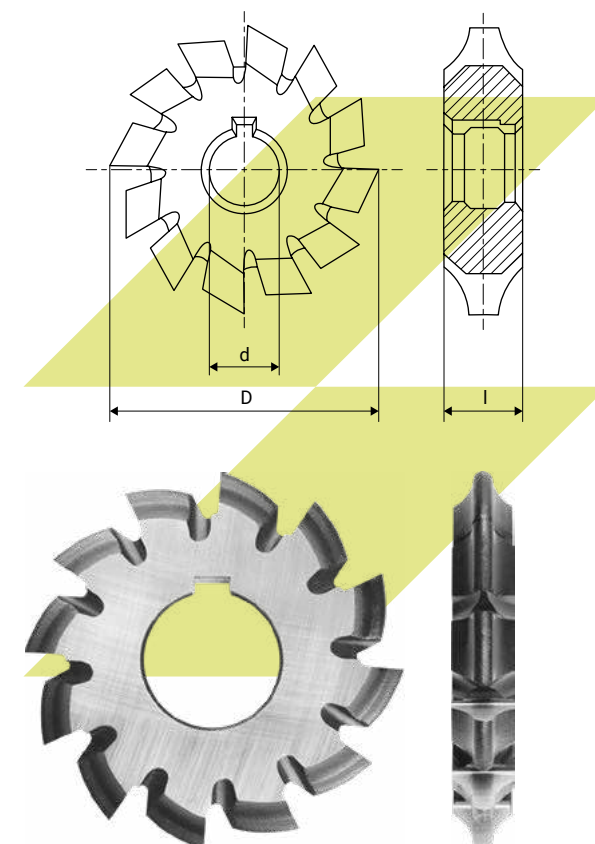

Фрезы червячные из быстрорежущей стали мелкомодульные для цилиндрических зубчатых колес с эвольвентным профилем, 25 мм

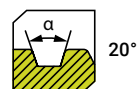
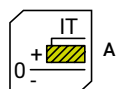
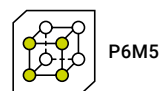

Артикул	Обозначение по ГОСТ	m	D, мм	d, мм	l, мм	Z, шт
112123	2510-4453	0,2	25,0	10,0	12,0	10
1184187	2510-4457	0,3	25,0	10,0	8,0	10
112130	2510-4457	0,3	25,0	10,0	16,0	10
1138826	2510-4462	0,5	25,0	10,0	8,0	10
112166	2510-4462	0,5	25,0	10,0	16,0	10
1134860	—	0,6	25,0	10,0	8,0	10
1262831	—	0,6	25,0	8,0	12,0	8

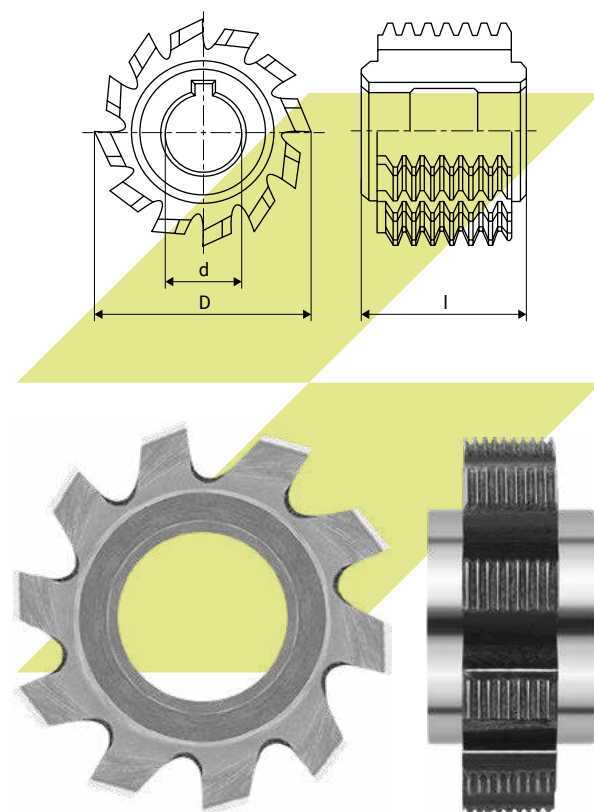

Фрезы червячные из быстрорежущей стали мелкомодульные для цилиндрических зубчатых колес с эвольвентным профилем, 32 мм

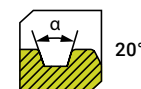
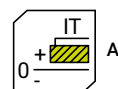

Артикул	Обозначение по ГОСТ	m	D, мм	d, мм	l, мм	Z, шт
1476968	2510-4473	0,25	32,0	13,0	16,0	10
112167	2510-4487	0,50	32,0	13,0	16,0	10
112183	2510-4494	0,60	32,0	13,0	16,0	10

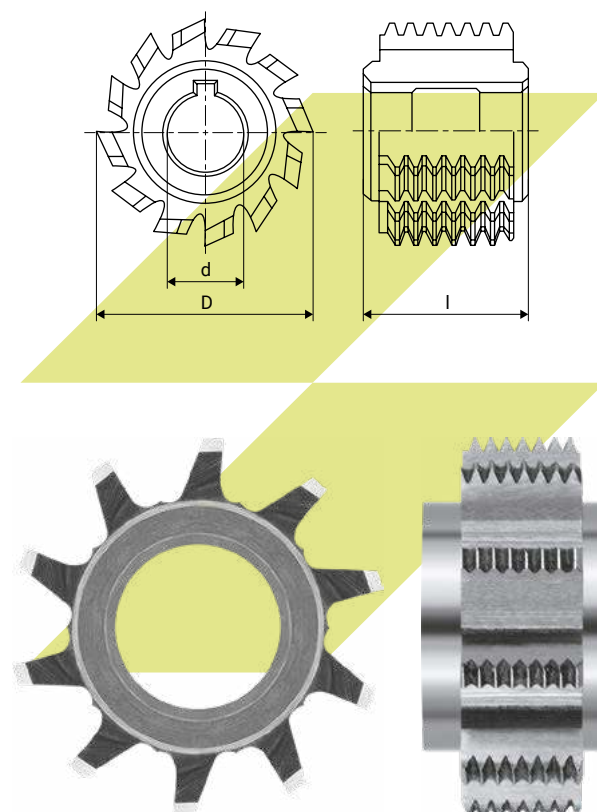

Фрезы червячные из быстрорежущей стали мелко модульные для цилиндрических зубчатых колес с эвольвентным профилем, 40 мм



Артикул	Обозначение по ГОСТ	m	D, мм	d, мм	l, мм	Z, шт
1530917	2510-4514	0,8	40,0	16,0	28,0	12
1530918	2510-4516	0,9	40,0	16,0	28,0	12

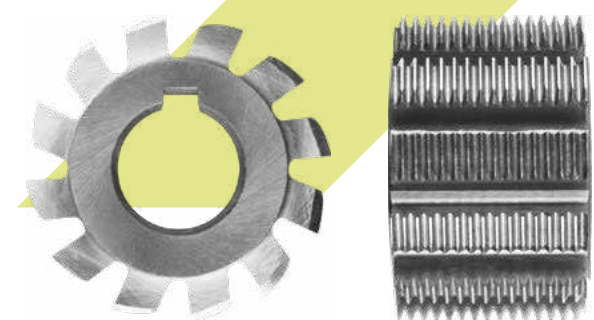
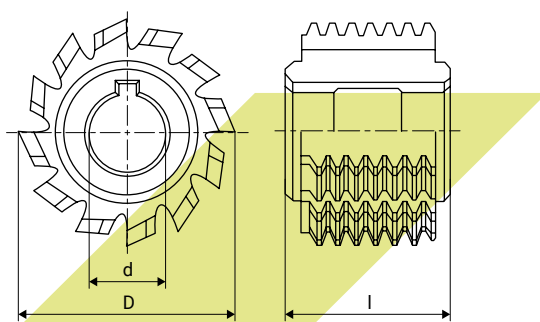
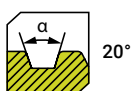
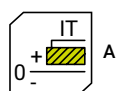
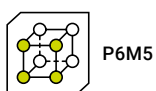

Фрезы червячные из быстрорежущей стали цельные чистовые для цилиндрических зубчатых колес с эвольвентным профилем



Артикул	Обозначение по ГОСТ	m	D, мм	d, мм	l, мм	Z, шт
1533134	2510-4243	1,00	40,0	16,0	50,0	12
1416071	2510-4116	1,00	50,0	22,0	32,0	12
1530919	2510-4247	1,00	50,0	22,0	50,0	12
1530920	2510-4256	1,25	50,0	22,0	70,0	12
1530921	2510-4269	1,75	63,0	27,0	80,0	12
1416072	2510-4143	2,00	63,0	27,0	50,0	12
1533135	2510-4274	2,00	63,0	27,0	90,0	12
1533136	2510-4281	2,50	71,0	27,0	63,0	12
1533137	2510-4285	2,75	71,0	27,0	63,0	12
1107729	2510-4165	3,25	80,0	32,0	71,0	10
1518378	2510-4169	3,50	80,0	32,0	71,0	10
112307	2510-4174	3,75	90,0	32,0	80,0	10
1103651	2510-4183	4,25	90,0	32,0	90,0	10
1134455	2510-4187	4,50	90,0	32,0	90,0	10
1220240	2510-4205	6,50	118,0	40,0	118,0	9
1416073	2510-4223	10,00	175,0	50,0	170,0	9

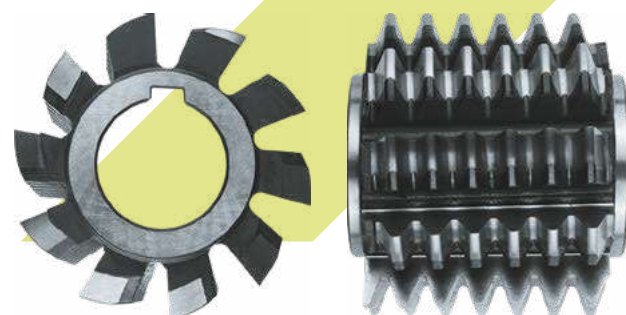
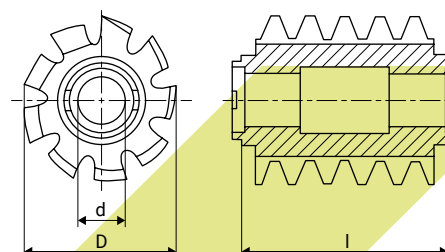
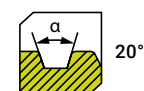
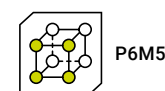
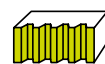

Фрезы червячные из быстрорежущей стали цельные чистовые для цилиндрических зубчатых колес с эвольвентным профилем

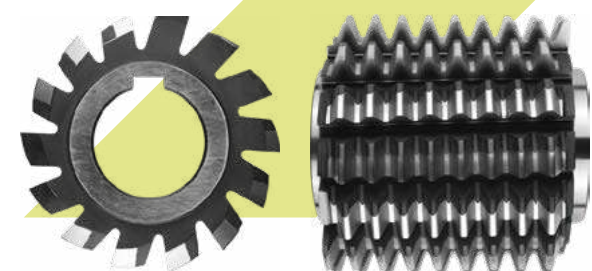
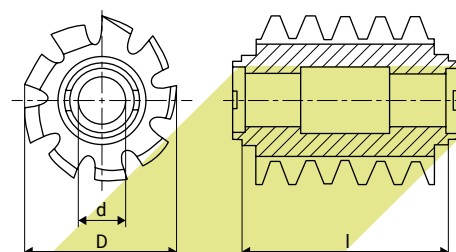
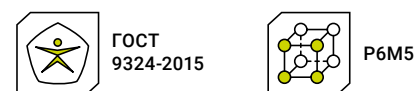

Артикул	Обозначение по ГОСТ	m	D, мм	L, мм	d, мм	Z, шт
1583646	—	1,00	32,0	20,0	10,0	12
1418496	2510-4112	1,00	40,0	32,0	16,0	12
1583647	—	1,25	40,0	25,0	10,0	10
1583648	—	1,25	50,0	50,0	22,0	14
1583649	—	1,50	40,0	25,0	10,0	10
1583650	—	1,50	55,0	55,0	22,0	14
1583651	—	2,00	40,0	30,0	10,0	10
1336305	—	2,00	65,0	60,0	27,0	14
1583652	—	2,50	70,0	65,0	27,0	14
1583653	—	3,00	75,0	70,0	32,0	14
1583654	—	4,00	85,0	80,0	32,0	14
115567	2510-4034	4,50	125,0	125,0	50,0	14
1583655	—	5,00	95,0	90,0	32,0	14
1583656	—	6,00	105,0	100,0	32,0	12
1583657	—	8,00	120,0	140,0	32,0	10
1583658	9324-2015	10,00	130,0	170,0	32,0	10
1583659	9324-2015	12,00	160,0	200,0	40,0	9

Фрезы червячные из быстрорежущей стали чистовые для шлицевых валов с эвольвентным профилем

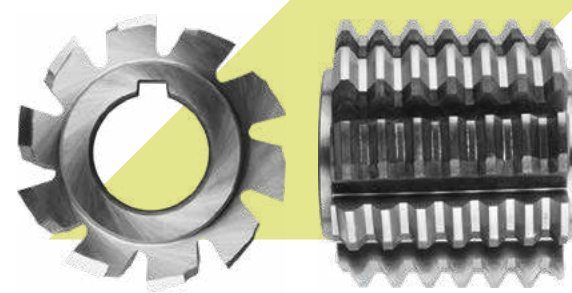
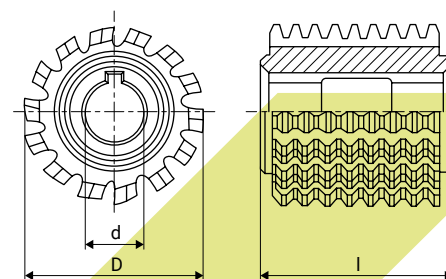
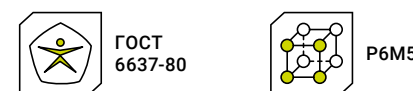

Артикул	Обозначение по ГОСТ	m	D, мм	d, мм	l, мм	Z, шт
1256750	2520-0661	0,50	50,0	22,0	32,0	12
1256751	2520-0662	0,50	50,0	22,0	32,0	12
1256752	2520-0663	0,60	50,0	22,0	32,0	12
1256753	2520-0664	0,60	50,0	22,0	32,0	12
1256754	2520-0665	0,80	50,0	22,0	32,0	12
1256755	2520-0666	0,80	50,0	22,0	32,0	12
1256756	2520-0667	1,00	50,0	22,0	32,0	12
1256757	2520-0668	1,00	50,0	22,0	32,0	12
1256758	2520-0669	1,25	50,0	22,0	40,0	12
1256759	2520-0671	1,25	50,0	22,0	40,0	12
1479914	2520-0672	1,50	56,0	22,0	45,0	12
1479915	2520-0673	1,50	56,0	22,0	45,0	12
1256760	2520-0674	2,00	63,0	27,0	50,0	12
1256761	2520-0675	2,00	63,0	27,0	50,0	12
1416050	2520-0676	2,50	71,0	27,0	63,0	10
1416051	2520-0677	2,50	71,0	27,0	63,0	10
1416980	2520-0678	3,00	80,0	32,0	71,0	10
1416981	2520-0679	3,00	80,0	32,0	71,0	10

Фрезы червячные из быстрорежущей стали для шлицевых валов лёгкой серии с прямобочным профилем



Артикул	Обозначение по ГОСТ	D, мм	d, мм	l, мм	Z, шт	z*d*D, мм
1226790	2520-0703	70,0	27,0	63,0	12	6x28x32
1142963	2520-0705	70,0	27,0	63,0	12	8x32x36
1131042	2520-0707	80,0	32,0	70,0	12	8x36x40
1131049	2520-0712	90,0	32,0	80,0	14	8x46x50

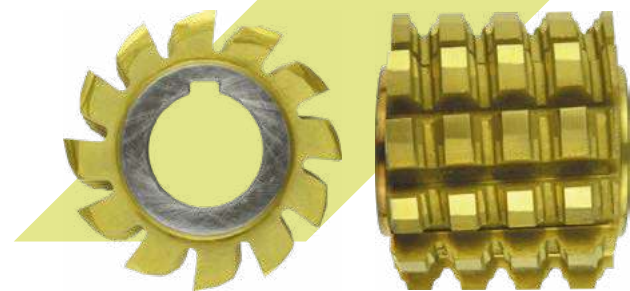
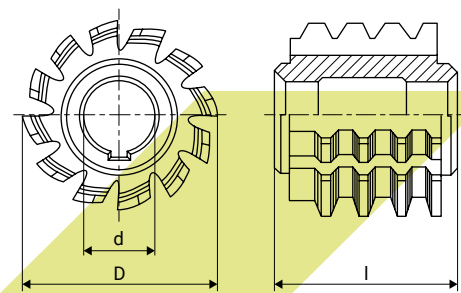

Фрезы червячные из быстрорежущей стали для шлицевых валов средней серии с прямобочным профилем



Артикул	Обозначение по ГОСТ	D, мм	d, мм	l, мм	Z, шт	z*d*D, мм
1108497	—	63,0	22,0	50,0	12	4x28x32
1177653	2520-0732	63,0	22,0	50,0	10	6x16x20
1479899	2520-0738	70,0	27,0	56,0	10	6x23x28
1479900	2520-0741	80,0	27,0	63,0	10	6x26x32
1103288	—	80,0	27,0	63,0	10	6x26x34
1131043	2520-0743	80,0	27,0	63,0	10	6x28x34
1108574	2520-0745	80,0	27,0	63,0	10	8x32x38
1148081	—	80,0	32,0	70,0	12	8x42x46
1177654	2520-0752	100,0	32,0	80,0	12	8x46x54
1271969	2520-0756	100,0	32,0	80,0	12	8x56x65
1336277	2520-0765	125,0	40,0	100,0	12	10x 92x102
1150781	—	125,0	40,0	112,0	12	10x112x125

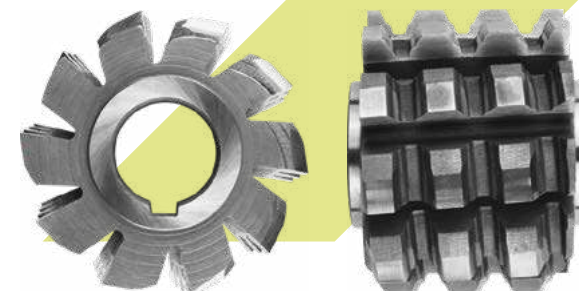
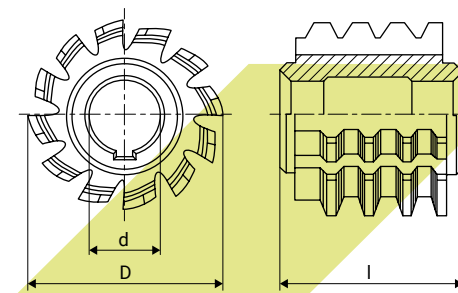

Фрезы червячные из быстрорежущей стали цельные для нарезания зубьев звездочек к приводным роликовым и втулочным цепям

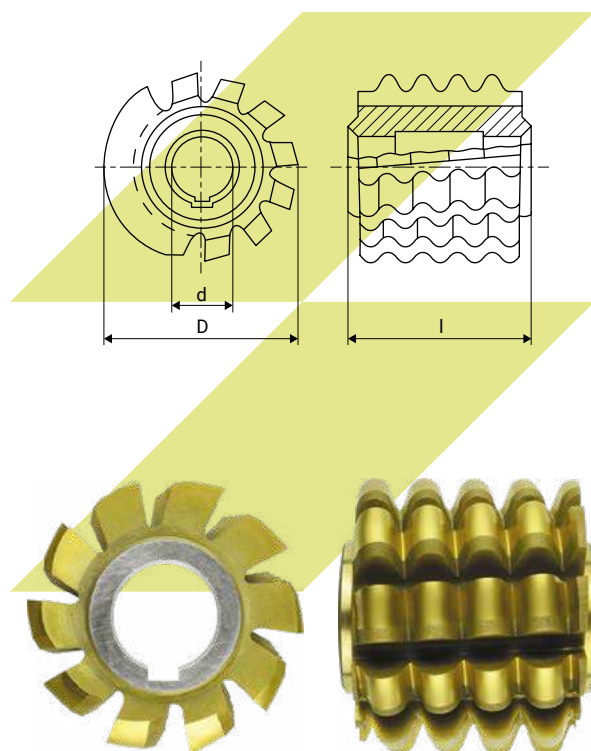

Артикул	Обозначение по ГОСТ	P, мм	D ролика	D, мм	l, мм	d, мм	Z, шт
1477404	2523-0132	8,000	5,00	63,0	50,0	27,0	12
1416944	—	9,525	5,00	80,0	71,0	32,0	12
116504	—	12,700	7,75	90,0	80,0	32,0	12
1479909	—	12,700	8,50	90,0	80,0	32,0	12
1284490	—	12,700	8,51	90,0	80,0	32,0	12
1477481	2523-0039	15,875	10,16	90,0	80,0	32,0	10

Фрезы червячные из быстрорежущей стали чистовые однозаходные для зубчатых цилиндрических колес передач Новикова с двумя линиями зацепления

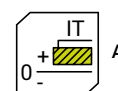

Артикул	m	D, мм	d, мм	l, мм	Z, шт
1236074	2,50	69,0	27,0	63,0	12
118831	6,30	120,0	40,0	120,0	9

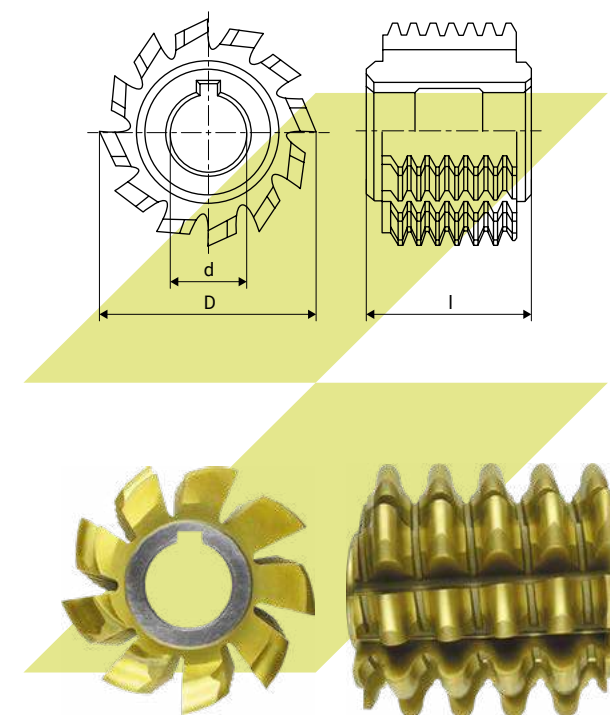

Фрезы червячные из твердого сплава для цилиндрических зубчатых колес с эвольвентным профилем

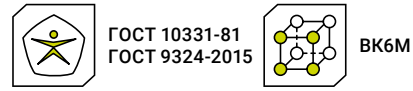

Артикул		m	D, мм	d, мм	l, мм
1851241	●	0,3	25,0	8,0	9,0
1851244	●	0,3	32,0	13,0	12,0
1851245	●	0,4	32,0	13,0	12,0
1851242	●	0,5	25,0	8,0	12,0
1851246	●	0,5	32,0	13,0	16,0
1851247	●	0,6	32,0	13,0	16,0
1851243	●	0,8	25,0	8,0	16,0
1851248	●	0,8	32,0	13,0	16,0
1851249	●	1	32,0	13,0	20,0

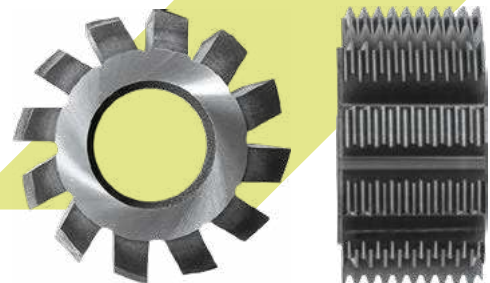
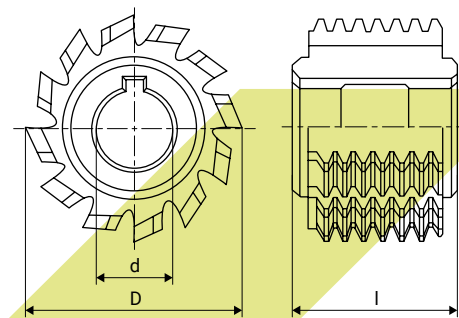

Протяжки шпоночные

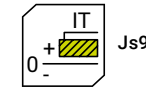
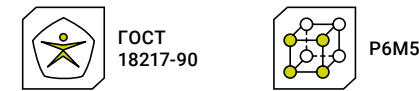

Артикул		Обозначение по ГОСТ	Паз, мм	H, мм	l, мм	L, мм	P, мм	Z, шт
1140371	●	2405-1064	10,0	22,0	612,0	905,0	9,0	69
1109804	●	2405-1068	10,0	22,0	476,0	830,0	14,0	35
1142974	●	2405-1071	10,0	22,0	504,0	900,0	18,0	29
1148593	○	2405-1077	12,0	28,0	770,0	1105,0	14,0	56
1140373	●	2405-1086	14,0	30,0	700,0	1035,0	10,0	71
1240190	●	2405-1098	14,0	30,0	608,0	960,0	14,0	39
1103580	●	2405-1099	14,0	30,0	684,0	1075,0	18,0	39
1171703	○	2405-1108	16,0	36,0	574,0	940,0	14,0	42
1148075	●	2405-1111	16,0	36,0	684,0	1090,0	18,0	39
1110387	○	2405-1119	18,0	40,0	896,0	1285,0	16,0	57
1148077	●	2405-1122	18,0	40,0	640,0	1030,0	16,0	41
1179278	○	2405-1124	18,0	40,0	666,0	1110,0	18,0	38
1141816	○	2405-1128	20,0	45,0	854,0	1230,0	14,0	62
1177738	●	2405-1135	20,0	45,0	740,0	1180,0	20,0	38
117732	●	2405-1137	20,0	45,0	832,0	1320,0	26,0	33

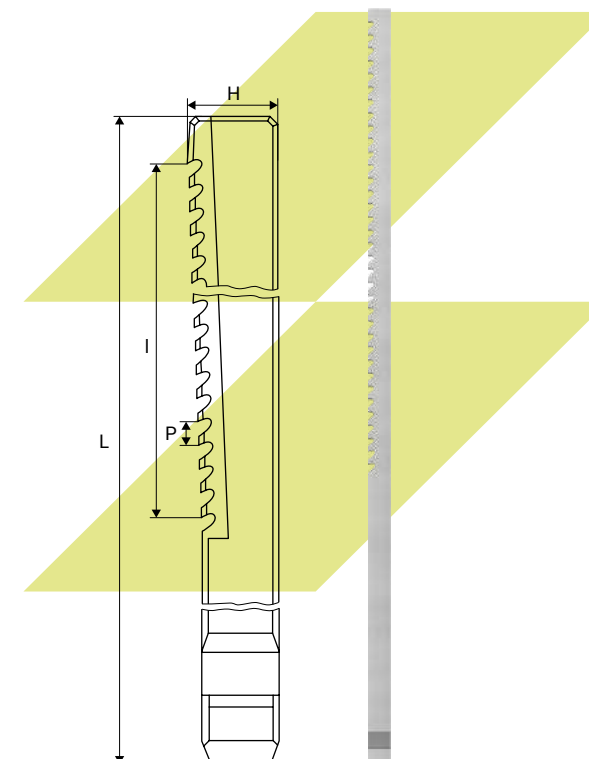

Протяжки шпоночные

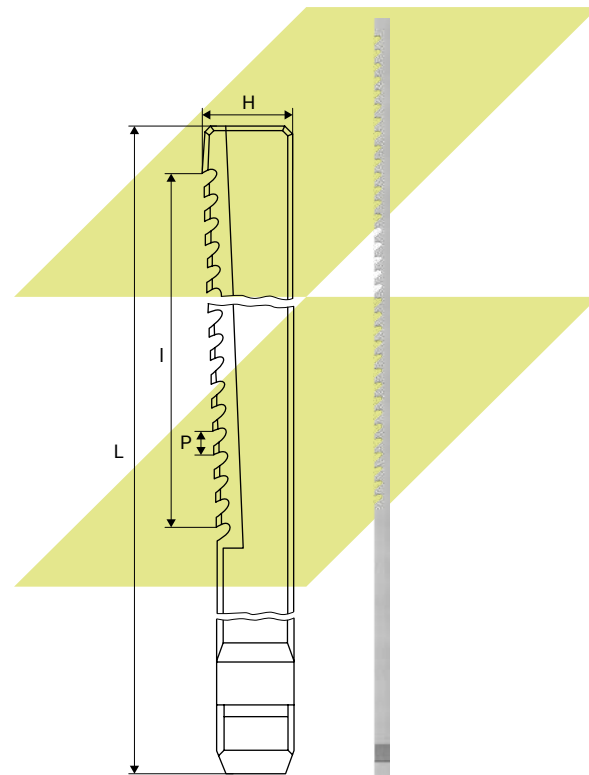
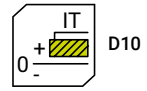

Артикул	Обозначение по ГОСТ	Паз, мм	H, мм	I, мм	L, мм	P, мм	Z, шт
1142969	2405-1074	12,0	28,0	630,0	945,0	9,0	71
116008	2405-1083	12,0	28,0	828,0	1190,0	18,0	47
1149346	2405-1123	18,0	40,0	640,0	1030,0	16,0	41
1110390	2405-1145	22,0	45,0	864,0	1310,0	24,0	37

Резцы зубострогальные

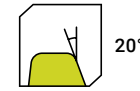
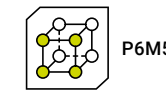

Артикул	Обозначение по ГОСТ	Модуль	L, мм
1128136	2550-0001	m 0,3–0,35	40,0
1108439	2550-0007	m 0,6–0,7	40,0
1105233	2550-0013	m 1,0–1,125	40,0
1105234	2550-0015	m 1,25–1,375	40,0

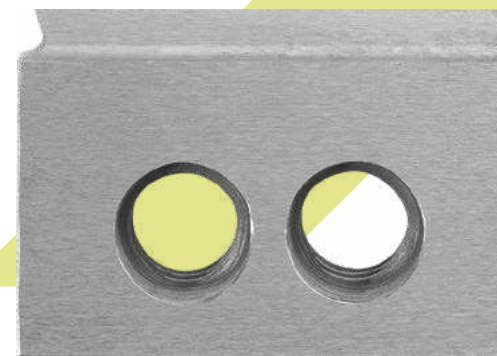
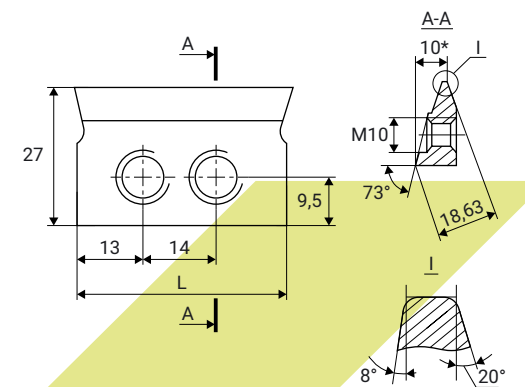

Резцы зубострогальные

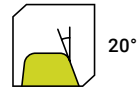
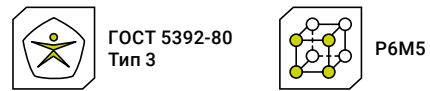

Артикул	Обозначение по ГОСТ	Модуль	L, мм
1102750	2550-0038	m 1,0–1,125	100,0
1379207	2550-0039	m 1,25–1,375	100,0
1102753	2550-0044	m 3,0–3,25	100,0
1103295	2550-0047	m 5,0–5,5	100,0
1111806	2550-0048	m 6,0–6,5	100,0
1518400	2550-0053	m 10,0	100,0

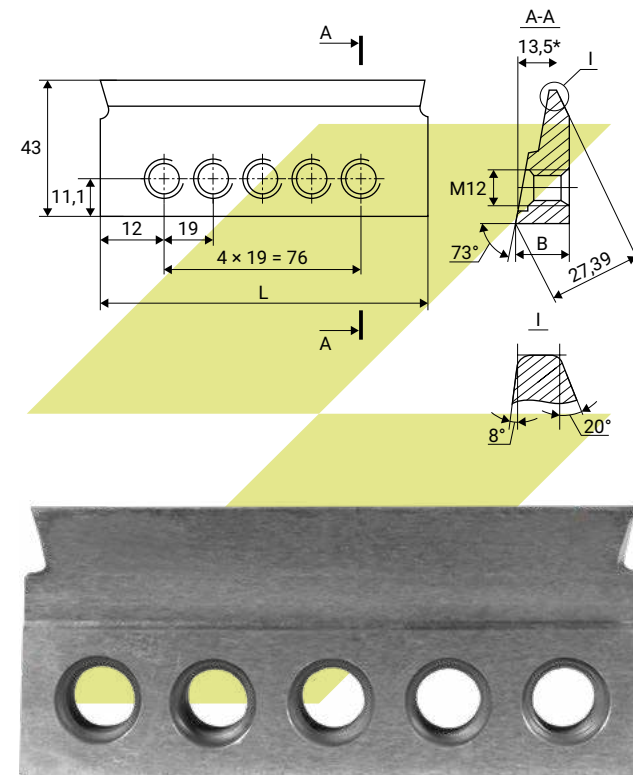

Для заметок

Dotted lines for taking notes.

Обработка зубчатых и шлицевых соединений

Обработка зубчатых и шлицевых соединений

Инструментальная и станочная оснастка

Патроны сверлильные	677
Ключевые ПС	677
Бесключевые ПСС	678
Бесключевые ВТ, ISO	679
Бесключевые с хвостовиком КМ	680
Резьбовые ПСР	681
Резьбовые ПССР	682
Втулки переходные	683
Оправки	689
Для сверлильных патронов	689
Для дисковых фрез	692
Для насадных торцевых фрез	695
Токарная оснастка	699
Патроны токарные	699
Кулачки к токарным патронам	701
Центры вращающиеся	703
Центры упорные, полуцентры	714
Фрезерная оснастка	722
Тиски	722
Столы поворотные	723
УДГ	726

Патроны сверлильные

Сверильный патрон представляет собой приспособление, в котором крепится сверло, зенкер, метчик или другая оснастка при работе на станке или с ручной дрелью. Патроны зажимают хвостовик инструмента и предотвращают его смещение относительно обрабатываемой детали. При станочных работах патрон закрепляется в шпинделе станка и вращается вместе с ним.



Втулки переходные

Переходные втулки являются элементом оснастки металлорежущего станка, предназначенным для установки инструмента с различными конусами Морзе. Применяются, если геометрическая форма и размер инструмента не совпадают с параметрами шпинделя станка. Втулка фиксируется в шпинделе благодаря пластической и упругой деформации. Дополнительную надежность обеспечивают силы трения между коническими поверхностями.



Оправки

Оправки используются для закрепления инструмента в металлообрабатывающих станках. Имеют стабильную конструкцию, отличную производительность и длительный срок службы. Обеспечивают надежное центрирование и фиксацию режущего инструмента с минимальным биением.



Токарная оснастка

Токарная оснастка необходима для надежного крепления заготовок различного размера и формы на шпиндель. Позволяет производить обработку на высоких скоростях при минимальном биении, обеспечивает более надежную фиксацию заготовок, особенно при работе с тяжелыми деталями.



Фрезерная оснастка

Фрезерная оснастка фиксирует обрабатываемую деталь и заготовку на стадии финишной обработки и доводки поверхностей на фрезерных и шлифовальных станках. Незаменима при фрезеровании поверхностей различного профиля, расположенных под углом, изготовлении и обработке отверстий и других металлообрабатывающих работ без переустановки обрабатываемой детали.



Условные обозначения

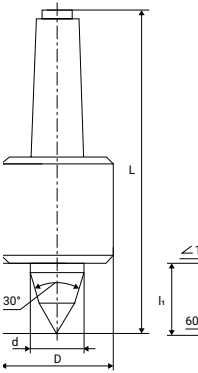
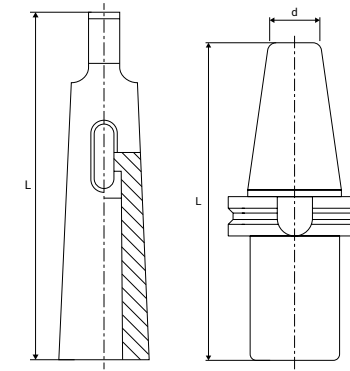

L – Общая длина
d – Общая длина

Серия



Короткая



Длинная



Стандарт



Крепление



Вид кулачков



Количество кулачков



Материал



Конусность

Наличие инструмента

- На складе в Нижнем Новгороде
- Под заказ

Патроны сверлильные

	Трехлачковые, ключевые, ПС	Самозажимные, бесключевые, ПСС	Самозажимные с хвостовиком, бесключевые, ВТ, ISO	Самозажимные с хвостовиком КМ, бесключевые
Стандарт	ГОСТ 8522-79	–	–	–
Страница	677	678	679	680
				

	Резьбовые с ключом, ПСР	Самозажимные резьбовые, бесключевые, ПССР
Страница	681	682
		



Втулки переходные

	Короткие		Длинные		Для концевых фрез	
Стандарт	ГОСТ 13598-85	ГОСТ 13598-85	ГОСТ 13598-85	ГОСТ 13598-85	ГОСТ 13789-68	ГОСТ 13789-68
Серия	Короткая	Короткая	Длинная	Длинная	–	–
Страница	683	684	685	686	687	688
						

Оправки

	Для сверлильных патронов с конусом Морзе		
Стандарт	ГОСТ 2682-86, Исполнение 1	ГОСТ 2682-86, Исполнение 2	ГОСТ 2682-86, Исполнение 3
Страница	689	690	691
			

Оправки



	Для дисковых фрез		
Стандарт	ГОСТ 25827-93 DIN69871-A исполнение 2	ГОСТ 25827-93 исполнение 3	ГОСТ 25827-93 MA S 403
Конусность	7:24	7:24	7:24
Страница	692	693	694
			

	Для насадных торцевых фрез			
Стандарт	ГОСТ 25827-93 DIN2080 исполнение 1	ГОСТ 25827-93 DIN69871-A исполнение 2	ГОСТ 25827-93 исполнение 3	ГОСТ 25827-93 MA S 403
Конусность	7:24	7:24	7:24	7:24
Страница	695	696	697	698
				





Патроны токарные

	ГОСТ 2675-80	ГОСТ 2675-80
Стандарт	ГОСТ 2675-80	ГОСТ 2675-80
Крепление	Конус	Планшайба
Кулачки	Цельные	Цельные
Количество кулачков	3	3
Страница	699	700
		

Кулачки к патрону



	Обратные	Прямые
Стандарт	ГОСТ 2675-80	ГОСТ 2675-80
Страница	701	702
		

Токарные центры

	Станочные вращающиеся				
Стандарт	ГОСТ 8742-75 тип А исполнение 1	ГОСТ 8742-75 тип А исполнение 1	ГОСТ 8742-75 тип А исполнение 2	ГОСТ 8742-75 исполнение 1	ГОСТ 8742-75 исполнение 2
Материал	–	–	–	ВК8	ВК8
Страница	703	704	705	706	707
					

	Станочные вращающиеся ЧПУ				Вращающиеся грибковые	
Стандарт	ГОСТ 8742-75 Тип А исполнение 1	ГОСТ 8742-75 Тип А исполнение 1	ГОСТ 8742-75 Тип А исполнение 2	ГОСТ 8742-75 Тип А исполнение 2	ГОСТ 8742-75 тип Б	ГОСТ 8742-75 тип Б
Материал	–	–	–	–	–	–
Страница	708	709	710	711	712	713
						

Токарные центры

	Центры упорные				Полуцентры упорные	
Стандарт	ГОСТ 13214-79 исполнение 1	ГОСТ 13214-79 исполнение 1	ГОСТ 13214-79 исполнение 2 с пластиной	ГОСТ 13214-79 исполнение 2 с пластиной	ГОСТ 2576-79 исполнение 1	ГОСТ 2576-79 исполнение 1
Материал	–	–	ВК8	ВК8	–	–
Страница	714	715	716	717	718	719
						

Токарные центры

	Полуцентры упорные	
Стандарт	ГОСТ 2576-79 исполнение 2 с пластиной	ГОСТ 2576-79 исполнение 2 с пластиной
Материал	ВК8	ВК8
Страница	720	721
		

Тиски

	Станочные неповоротные прецизионные
Стандарт	ТИП 3320 QGG
Материал	Сталь
Страница	722
	

Стол поворотный и УДГ

	Горизонтально-вертикальный круглый	Горизонтальный круглый	Наклоняемый круглый
Серия	TSL	TS	TSK
Страница	723	724	725
			

Универсальные делительные головки

	Без дополнительной комплектации	С дополнительной комплектацией
Страница	726	727
		

Патроны сверлильные трехкулачковые, ключевые



Артикул		Диапазон зажима		Посадка
		от	до	
1597163	●	0,6	6,0	B10
1718537	●	0,6	6,0	B10
1718538	●	1,5	10,0	B10
1343030	●	1,0	10,0	B12
1718539	●	1,5	10,0	B12
1718540	●	1,5	13,0	B12
1276562	●	1,0	13,0	B16
1718541	●	1,5	13,0	B16
1718542	●	3,0	16,0	B16
1254637	●	3,0	16,0	B16
1335368	●	3,0	16,0	B18
1718543	●	3,0	16,0	B18
1441672	○	5,0	20,0	B22

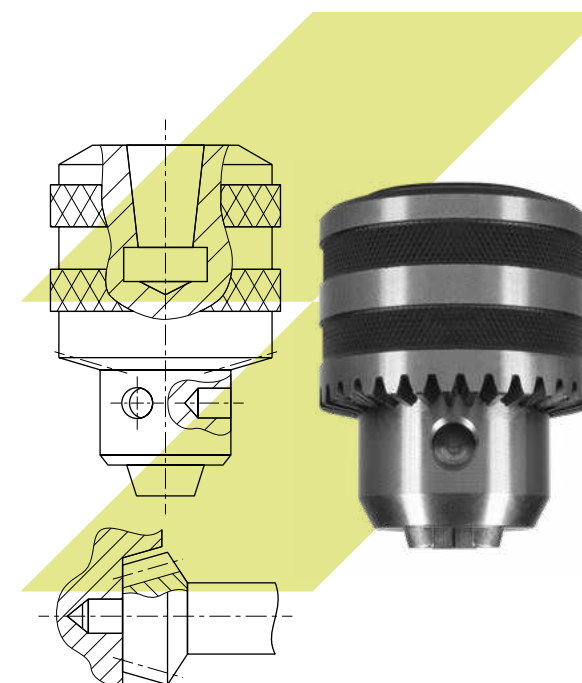

Патроны сверлильные самозажимные, бесключевые

Артикул		Диапазон зажима		Посадка
		от	до	
1228666	●	0,5	6,0	B10
1228667	●	0,5	8,0	B12
1228668	●	1,0	10,0	B12
1228669	●	1,0	13,0	B16
1228670	●	1,0	16,0	B18
1228671	●	5,0	20,0	B22

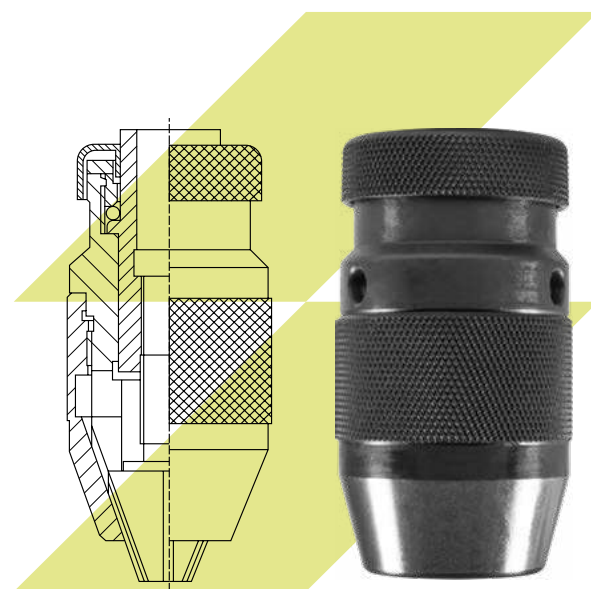

Патроны сверлильные самозажимные с хвостовиком, бесключевые BT, ISO

Артикул		Диапазон зажима		Посадка
		от	до	
1751948	○	1,0	8,0	BT30
1751949	○	1,0	13,0	BT30
1751950	○	1,0	13,0	BT40
1751951	○	3,0	16,0	BT40
1751952	○	5,0	20,0	BT40
1751953	○	3,0	16,0	BT50
1751954	○	5,0	20,0	BT50
1751955	○	1,0	10,0	ISO30
1751956	○	1,0	13,0	ISO30
1751957	○	1,0	13,0	ISO40
1751958	○	3,0	16,0	ISO40
1751959	○	5,0	20,0	ISO40
1751960	○	3,0	16,0	ISO50
1751961	○	5,0	20,0	ISO50



Патроны сверлильные самозажимные с хвостовиком КМ, бесключевые

Артикул		Диапазон зажима		Посадка
		от	до	
1751962	○	0,5	8,0	КМ2
1751963	○	1,0	10,0	КМ2
1751964	○	0,5	13,0	КМ2
1751965	○	1,0	13,0	КМ2
1751966	○	1,0	16,0	КМ2
1751967	○	0,5	13,0	КМ3
1751968	○	1,0	16,0	КМ3
1751969	○	0,5	13,0	КМ4
1751970	○	1,0	13,0	КМ4
1751971	○	1,0	16,0	КМ4
1751972	○	5,0	20,0	КМ5



Патроны сверлильные резьбовые с ключом

Артикул		Диапазон зажима		Посадка
		от	до	
1847413	○	0,6	6,0	3/8'-24UNF
1847414	○	1,5	10,0	1/2'-20UNF
1847415	○	1,5	10,0	M12,0x1,25
1847416	○	1,5	13,0	1/2'-20UNF
1847417	○	1,5	13,0	M12,0x1,25
1847418	○	3,0	16,0	1/2'-20UNF
1847419	○	3,0	16,0	M12,0x1,25

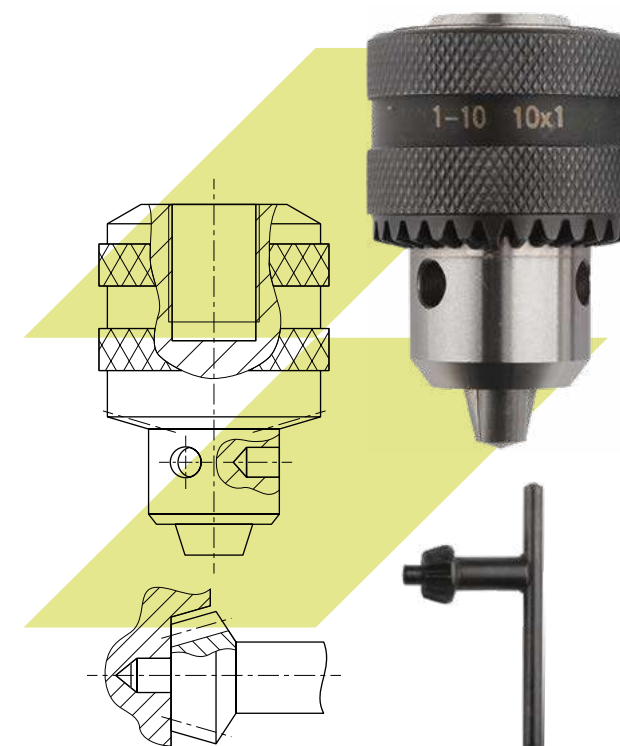

Патроны сверлильные самозажимные резьбовые, бесключевые

Артикул		Диапазон зажима		Посадка
		от	до	
1847420	○	0,8	10,0	1/2'-20UNF
1847421	○	0,8	10,0	3/8'-24UNF
1847422	○	0,8	10,0	M12,0×1,25
1847423	○	2,0	13,0	1/2'-20UNF
1847424	○	2,0	13,0	3/8'-24UNF
1847425	○	2,0	13,0	M12,0×1,25

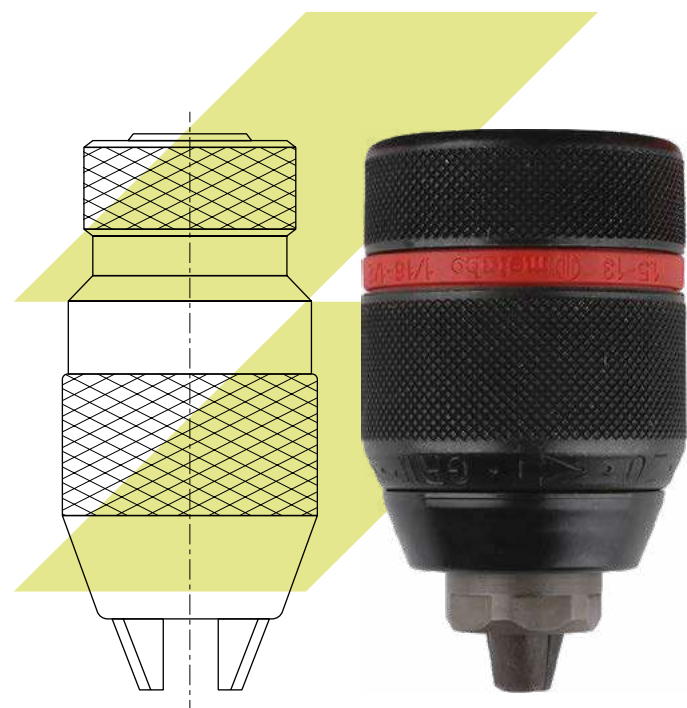

Втулки переходные короткие

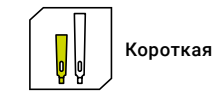

Артикул		Обозначение по ГОСТ	Радиальное биение, мм	Конус Морзе		L, мм
				наружн.	внутр.	
112909	●	6100-0141	0,01	2	1	92
112910	●	6100-0142	0,01	3	1	99
112911	●	6100-0143	0,01	3	2	112
112912	●	6100-0221	0,01	4	1	124
112913	●	6100-0144	0,01	4	2	124
100126	●	6100-0145	0,01	4	3	140
112914	●	6100-0222	0,01	5	1	156
112915	●	6100-0223	0,01	5	2	156
112916	●	6100-0146	0,01	5	3	156
112917	●	6100-0147	0,01	5	4	171
1275275	●	6100-0224	0,01	6	1	218
119452	●	6100-0225	0,01	6	2	218
119453	●	6100-0226	0,01	6	3	218
115527	●	6100-0148	0,01	6	4	218
118959	●	6100-0149	0,01	6	5	218

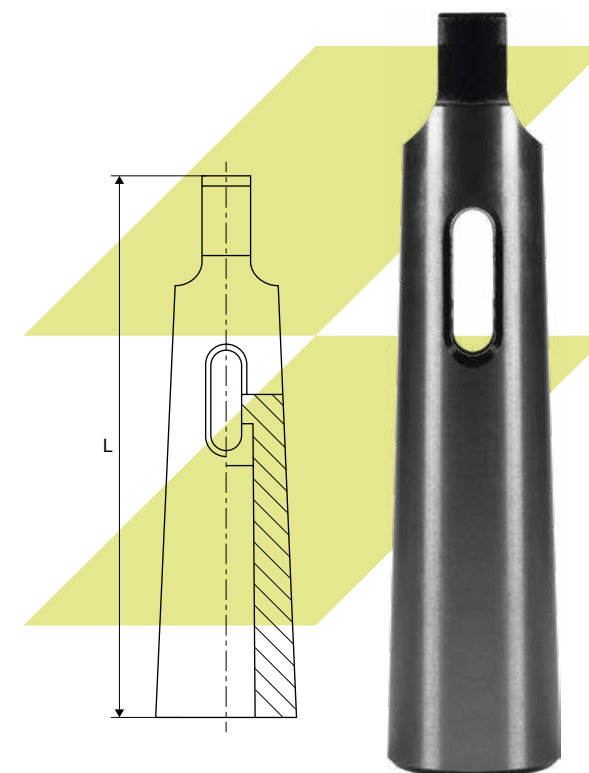

Втулки переходные короткие



ГОСТ
13598-85



Короткая

Артикул	Обозначение по ГОСТ	Радиальное биение, мм	Конус Морзе		L, мм
			наружн.	внутр.	
1847977	6100-0141	0,01	2	1	92
1847980	6100-0142	0,01	3	1	99
1847982	6100-0143	0,01	3	2	112
1847986	6100-0221	0,01	4	1	124
1847987	6100-0144	0,01	4	2	124
1847988	6100-0145	0,01	4	3	140
1847990	6100-0222	0,01	5	1	156
1847991	6100-0223	0,01	5	2	156
1847992	6100-0146	0,01	5	3	156
1847993	6100-0147	0,01	5	4	171
1847995	6100-0225	0,01	6	2	218
1847996	6100-0226	0,01	6	3	218
1847997	6100-0148	0,01	6	4	218
1847998	6100-0149	0,01	6	5	218



Втулки переходные длинные



ГОСТ
13598-85



Длинная

Артикул	Обозначение по ГОСТ	Радиальное биение, мм	Конус Морзе		L, мм
			наружн.	внутр.	
1131756	6100-0301	0,015	1	1	145
1585940	6100-0303	0,015	1	2	160
1131757	6100-0251	0,015	2	1	160
1846406	6100-0305	0,015	2	2	175
1260434	6100-0307	0,015	2	3	196
1265368	6100-0253	0,015	3	1	175
1265369	6100-0255	0,015	3	2	194
1265358	6100-0309	0,015	3	3	215
1265359	6100-0312	0,015	3	4	240
1847299	6100-0314	0,015	4	1	200
1847300	6100-0257	0,015	4	2	215
1847301	6100-0316	0,015	4	3	240
1293040	6100-0318	0,015	4	4	265
1275276	6100-0321	0,015	4	5	300
1584183	6100-0327	0,015	5	3	268
1847302	6100-0329	0,015	5	4	300
1269411	6100-0332	0,015	5	5	335
1757165	6100-0341	0,015	6	4	355
1269412	6100-0343	0,015	6	5	390

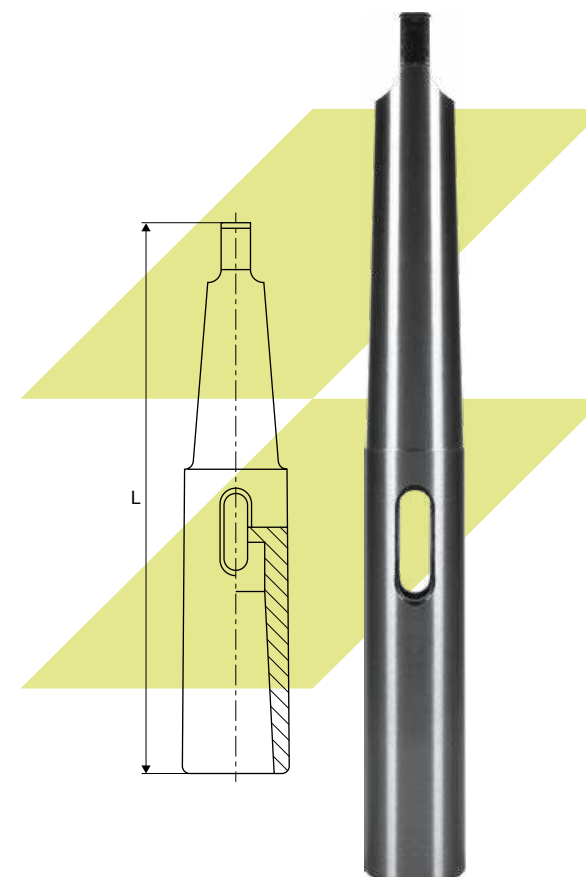

Втулки переходные длинные



ГОСТ
13598-85



Длинная

Артикул	Обозначение по ГОСТ	Радиальное биение, мм	Конус Морзе		L, мм
			наружн.	внутр.	
1847976	6100-0301	0,015	1	1	145
1847978	6100-0251	0,015	2	1	160
1847979	6100-0307	0,015	2	3	196
1847981	6100-0253	0,015	3	1	175
1847983	6100-0255	0,015	3	2	194
1847984	6100-0309	0,015	3	3	215
1847985	6100-0312	0,015	3	4	240
1847989	6100-0321	0,015	4	5	300
1847994	6100-0332	0,015	5	5	335

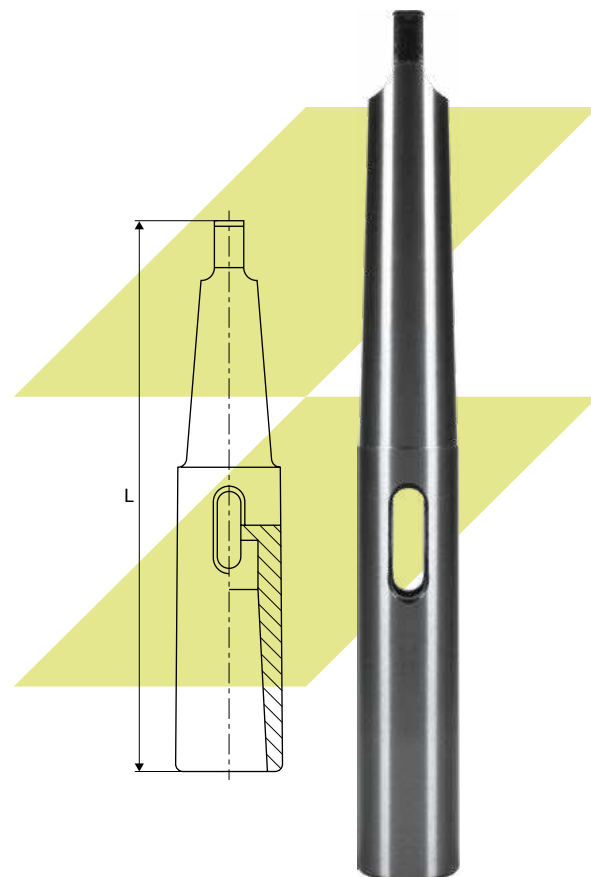

Втулки переходные для концевых фрез



ГОСТ
13789-68

Артикул	Обозначение по ГОСТ	Конус Морзе		L, мм
		наружн.	внутр.	
1258094	6101-0072	3	2	80
1241756	-	4	1	-
1241757	6101-0073	4	2	90
121758	6101-0074	4	3	90
116011	6101-0076	5	3	110
1256347	6101-0077	5	4	110

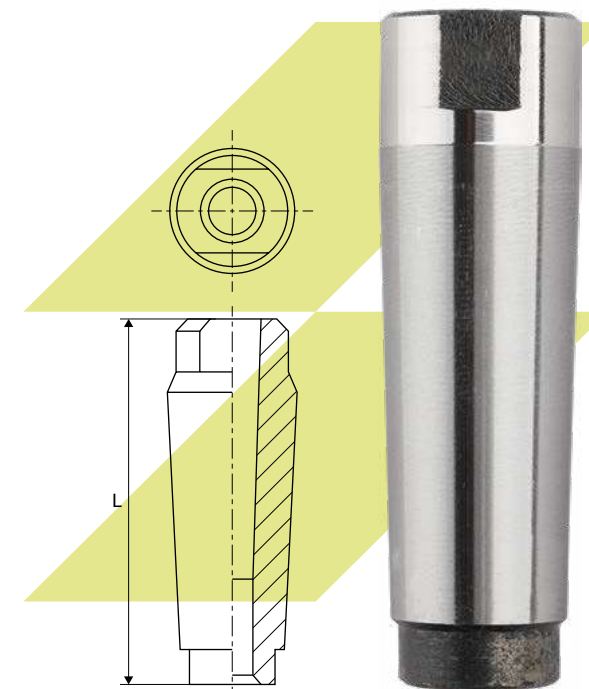

Втулки переходные для концевых фрез



ГОСТ
13789-68

Артикул	Обозначение по ГОСТ	Конус Морзе		L, мм
		наружн.	внутр.	
1847971	6101-0072	3	2	80
1847972	6101-0073	4	2	90
1847973	6101-0074	4	3	90
1847974	6101-0076	5	3	110
1847975	6101-0077	5	4	110

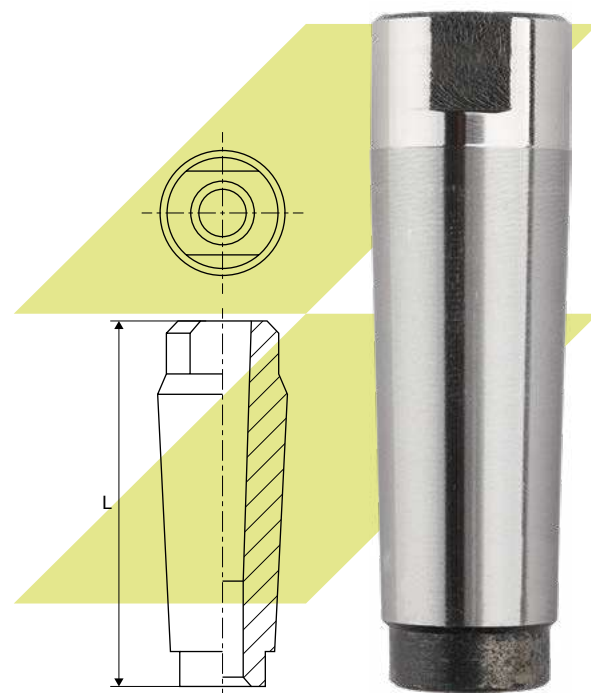

Оправки с конусом Морзе



ГОСТ 2682-86
Исполнение 1

Артикул	Обозначение по ГОСТ	Конус Морзе	Укороченный конус Морзе	L, мм
1144748	6039-0005	KM1	B12	90
1128506	6039-0007	KM1	B16	99
1128507	6039-0011	KM1	B18	107
1479483	6039-0016	KM2	B22	130

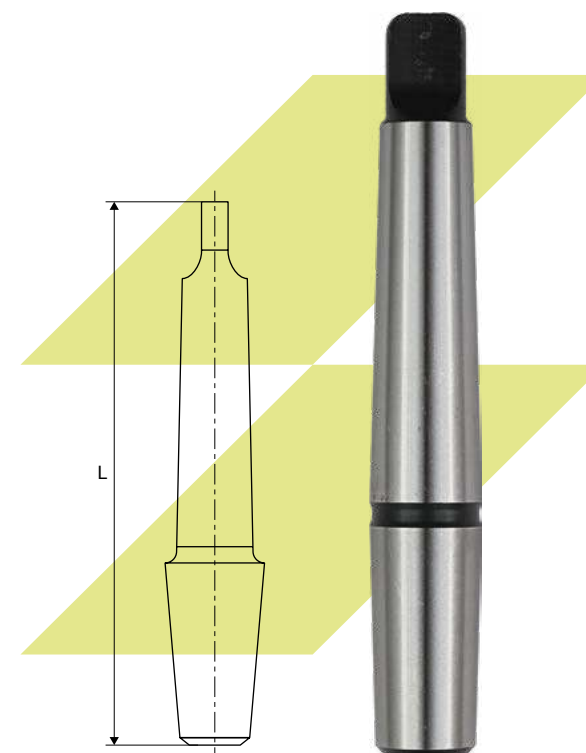

Оправки с конусом Морзе



ГОСТ 2682-86
Исполнение 2

Артикул	Обозначение по ГОСТ	Конус Морзе	Укороченный конус Морзе	L, мм
115545	6039-0003	KM2	B10	105
115546	6039-0006	KM2	B12	106
115547	6039-0008	KM2	B16	112
119454	6039-0022	KM3	B12	124
119456	6039-0009	KM3	B16	134
119457	6039-0013	KM3	B18	140
1418129	6039-0017	KM3	B22	149
1335828	6039-0010	KM4	B16	156
115802	6039-0014	KM4	B18	164
1418130	6039-0018	KM4	B22	176
1847411	6039-0020	KM4	B24	186
1335829	6039-0015	KM5	B18	196
1326447	6039-0019	KM5	B22	206
1847412	6039-0021	KM5	B24	221

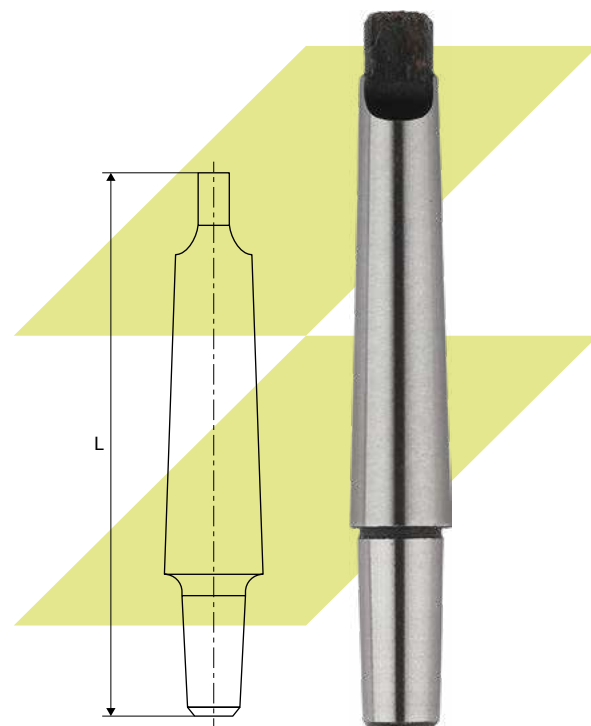

Оправки с конусом Морзе



ГОСТ 2682-86
Исполнение 3

Артикул	Обозначение по ГОСТ	Конус Морзе	Укороченный конус Морзе	L, мм
115548	6039-0012	KM2	B18	120
1847410	6039-0023	KM3	B24	157

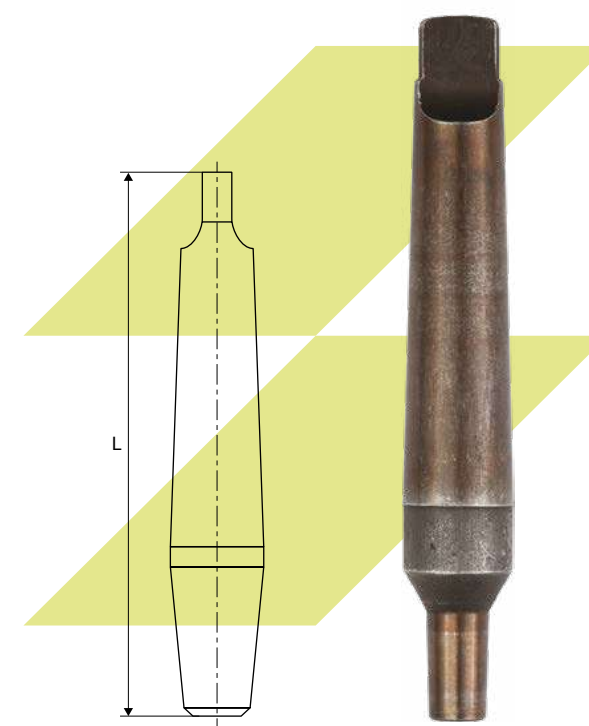

Оправки для дисковых фрез

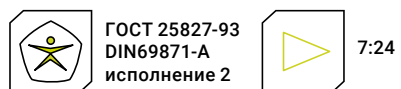

Производитель: Оршанский инструментальный завод

Артикул	Обозначение	Номер конуса	d, мм	L, мм
1847304	6222-4017-90	40	16	60
1847305	6222-4017	40	22	60
1847307	6222-4017-02	40	27	60
1847308	6222-4017-03	40	27	180
1847312	6222-4017-04	40	32	80
1847313	6222-4017-05	40	32	180
1847317	6222-4017-06	40	40	80
1847318	6222-4017-07	40	40	180
1847325	6222-4017-94	50	16	60
1847326	6222-4017-16	50	22	80
1847329	6222-4017-19	50	27	80
1847330	6222-4017-20	50	27	180
1847334	6222-4017-22	50	32	80
1847335	6222-4017-23	50	32	180
1847340	6222-4017-25	50	40	80
1847341	6222-4017-26	50	40	180
1847345	6222-4017-28	50	50	80
1847346	6222-4017-29	50	50	180

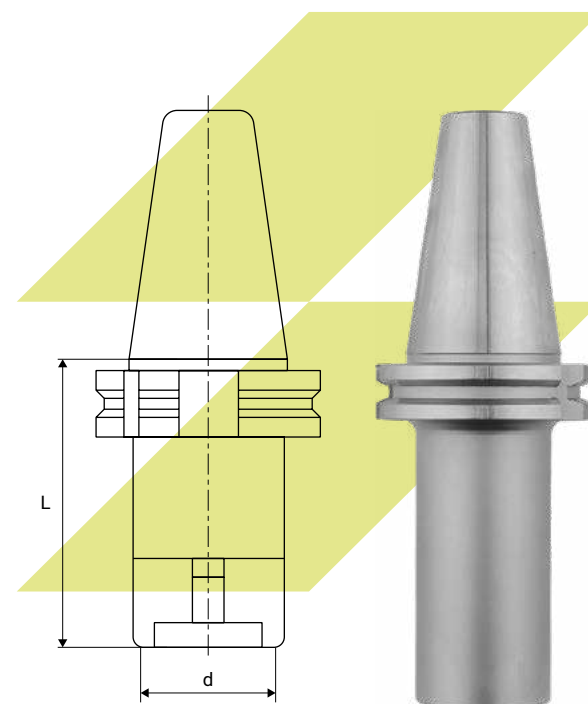

Оправки для дисковых фрез

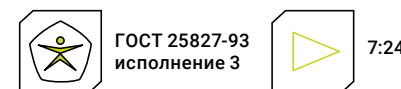

Производитель: Оршанский инструментальный завод

Артикул	Обозначение	Номер конуса	d, мм	L, мм
1377398	6222-4017-96	40	16	60
1377399	6222-4017-30	40	22	60
1377400	6222-4017-32	40	27	60
1847309	6222-4017-33	40	27	180
1614736	6222-4017-34	40	32	80
1847314	6222-4017-35	40	32	180
1847319	6222-4017-36	40	40	80
1847320	6222-4017-37	40	40	180
1847323	6222-4017-100	50	16	60
1847327	6222-4017-46	50	22	80
1847331	6222-4017-49	50	27	80
1105071	6222-4017-50	50	27	180
1582650	6222-4017-52	50	32	80
1847336	6222-4017-53	50	32	180
1425812	6222-4017-55	50	40	80
1847342	6222-4017-56	50	40	180
1847347	6222-4017-58	50	50	80
1847348	6222-4017-59	50	50	180

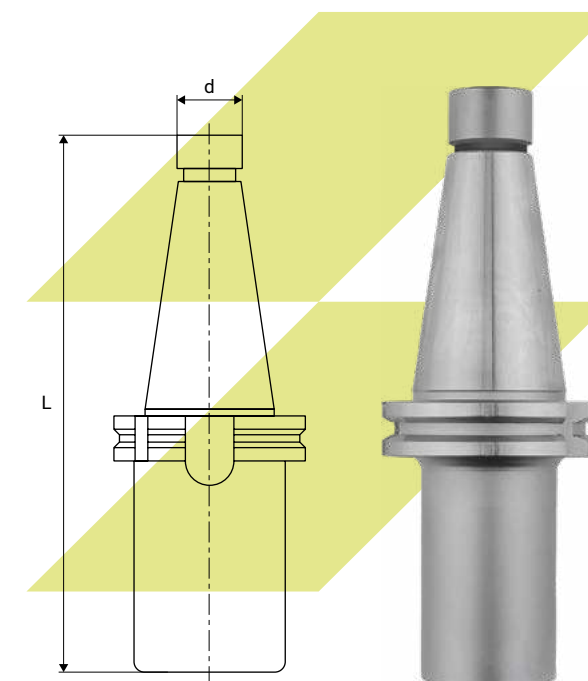

Оправки для дисковых фрез

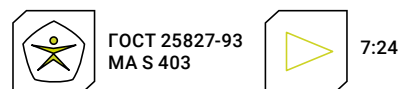

Производитель: Оршанский инструментальный завод

Артикул	Обозначение	Номер конуса	d, мм	L, мм
1847303	6222-4017-102	40	16	60
1847306	6222-4017-60	40	22	60
1847310	6222-4017-62	40	27	60
1847311	6222-4017-63	40	27	180
1847315	6222-4017-64	40	32	80
1847316	6222-4017-65	40	32	180
1847321	6222-4017-66	40	40	80
1847322	6222-4017-67	40	40	180
1847324	6222-4017-106	50	16	60
1847328	6222-4017-76	50	22	80
1847332	6222-4017-79	50	27	80
1847333	6222-4017-80	50	27	180
1847337	6222-4017-82	50	32	80
1847338	6222-4017-83	50	32	180
1847343	6222-4017-85	50	40	80
1847344	6222-4017-86	50	40	180
1847349	6222-4017-88	50	50	80
1847350	6222-4017-89	50	50	180

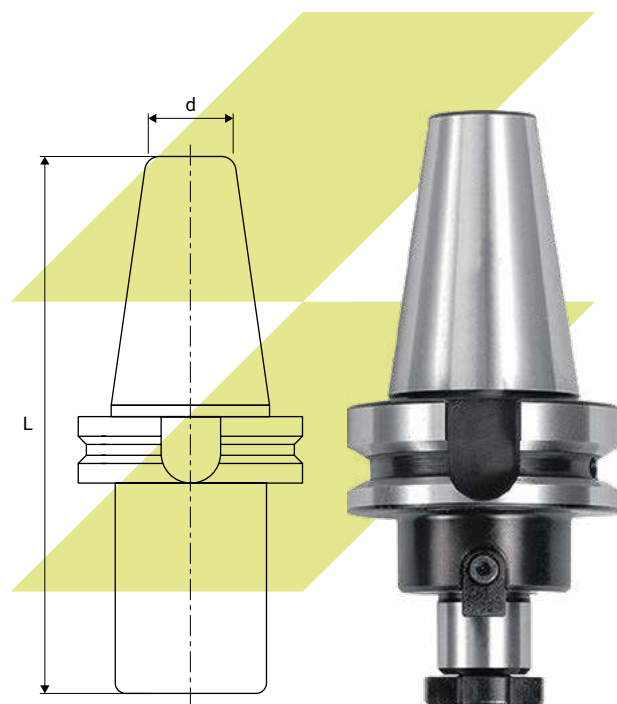

Оправки для насадных торцевых фрез

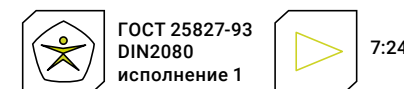

Производитель: Оршанский инструментальный завод

Артикул	Обозначение	Номер конуса	d, мм	L, мм	L ₁ , мм	D, мм
1847355	6222-4024-32	40	16	50	16	32
1847356	6222-4024-33	40	16	70	16	32
1847363	6222-4024-34	40	22	70	19	40
1847364	6222-4024-35	40	22	100	19	40
1847371	6222-4024-36	40	27	70	21	48
1847372	6222-4024-37	40	27	100	21	48
1847379	6222-4024-38	40	32	60	24	58
1847380	6222-4024-39	40	32	100	24	58
1847386	6222-4024-40	50	22	70	19	40
1847387	6222-4024-41	50	22	100	19	40
1847394	6222-4024-42	50	27	70	21	48
1847395	6222-4024-43	50	27	100	21	48
1242912	6222-4024-44	50	32	60	24	58
1847402	6222-4024-45	50	32	100	24	58
1847408	6222-4024-46	50	40	50	27	70
1847409	6222-4024-47	50	40	100	27	70

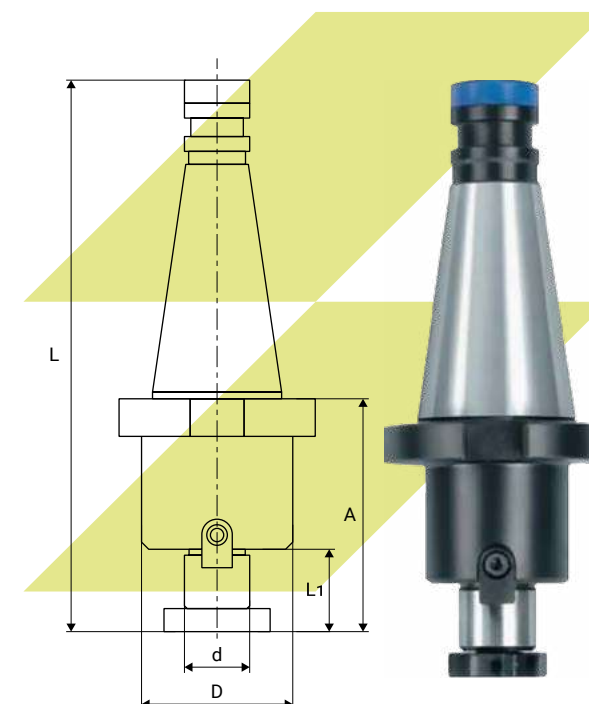

Оправки для насадных торцевых фрез

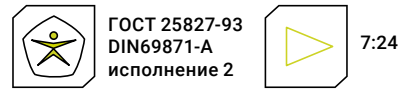

Производитель: Оршанский инструментальный завод

Артикул	Обозначение	Номер конуса	d, мм	L, мм
1847351	6222-4024	40	16	50
1847352	6222-4024-01	40	16	70
1847359	6222-4024-02	40	22	70
1847360	6222-4024-03	40	22	100
1847367	6222-4024-04	40	27	70
1847368	6222-4024-05	40	27	100
1847375	6222-4024-06	40	32	60
1847376	6222-4024-07	40	32	100
1847383	6222-4024-08	50	22	70
1847384	6222-4024-09	50	22	100
1847390	6222-4024-10	50	27	70
1847391	6222-4024-11	50	27	100
1847398	6222-4024-12	50	32	60
1847399	6222-4024-13	50	32	100
1847405	6222-4024-14	50	40	50
1847406	6222-4024-15	50	40	100

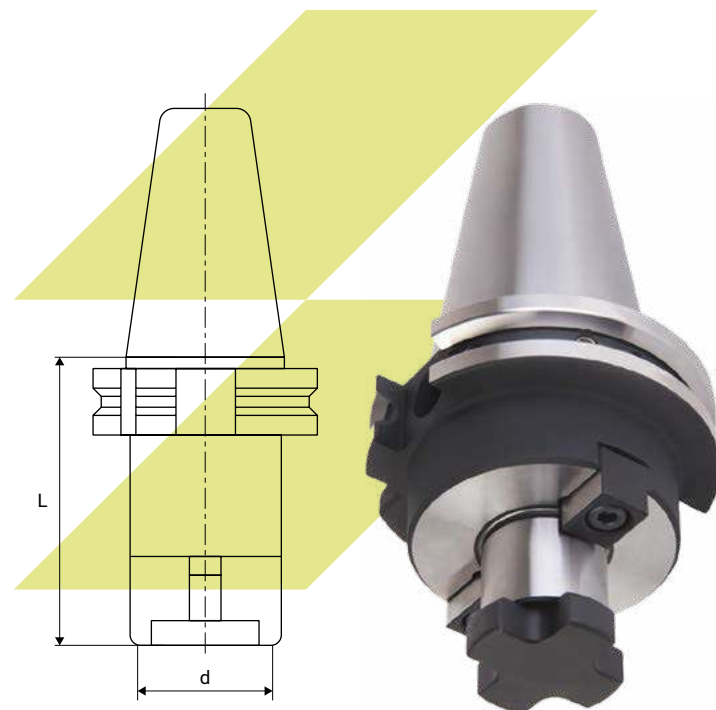

Оправки для насадных торцевых фрез

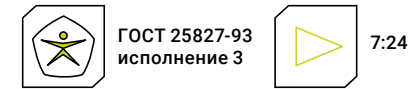

Производитель: Оршанский инструментальный завод

Артикул	Обозначение	Номер конуса	d, мм	L, мм
1847353	6222-4024-16	40	16	50
1847354	6222-4024-17	40	16	70
1847361	6222-4024-18	40	22	70
1847362	6222-4024-19	40	22	100
1847369	6222-4024-20	40	27	70
1847370	6222-4024-21	40	27	100
1847377	6222-4024-22	40	32	60
1847378	6222-4024-23	40	32	100
1425061	6222-4024-24	50	22	70
1847385	6222-4024-25	50	22	100
1847392	6222-4024-26	50	27	70
1847393	6222-4024-27	50	27	100
1847400	6222-4024-28	50	32	60
1847401	6222-4024-29	50	32	100
1242913	6222-4024-30	50	40	50
1847407	6222-4024-31	50	40	100

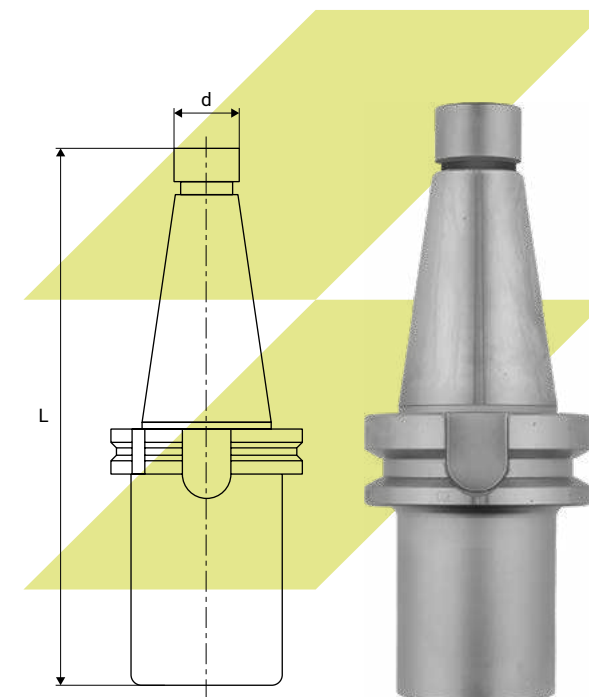

Оправки для насадных торцевых фрез

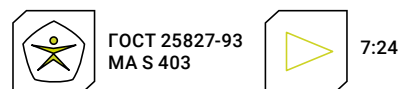

Производитель: Оршанский инструментальный завод

Артикул	Обозначение	Номер конуса	d, мм	L, мм
1847357	6222-4024-48	40	16	50
1847358	6222-4024-49	40	16	70
1847365	6222-4024-50	40	22	70
1847366	6222-4024-51	40	22	100
1847373	6222-4024-52	40	27	70
1847374	6222-4024-53	40	27	100
1847381	6222-4024-54	40	32	60
1847382	6222-4024-55	40	32	100
1847388	6222-4024-56	50	22	70
1847389	6222-4024-57	50	22	100
1847396	6222-4024-58	50	27	70
1847397	6222-4024-59	50	27	100
1847403	6222-4024-60	50	32	60
1847404	6222-4024-61	50	32	100
1343426	6222-4024-62	50	40	50
1343427	6222-4024-63	50	40	100

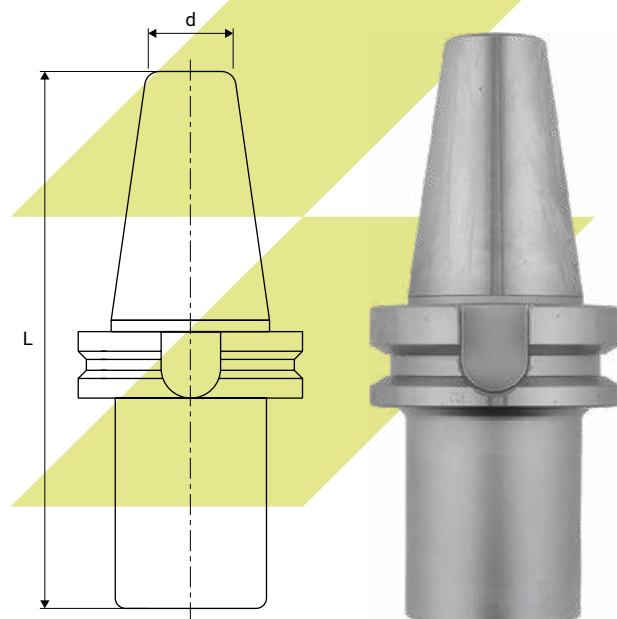

Патроны токарные

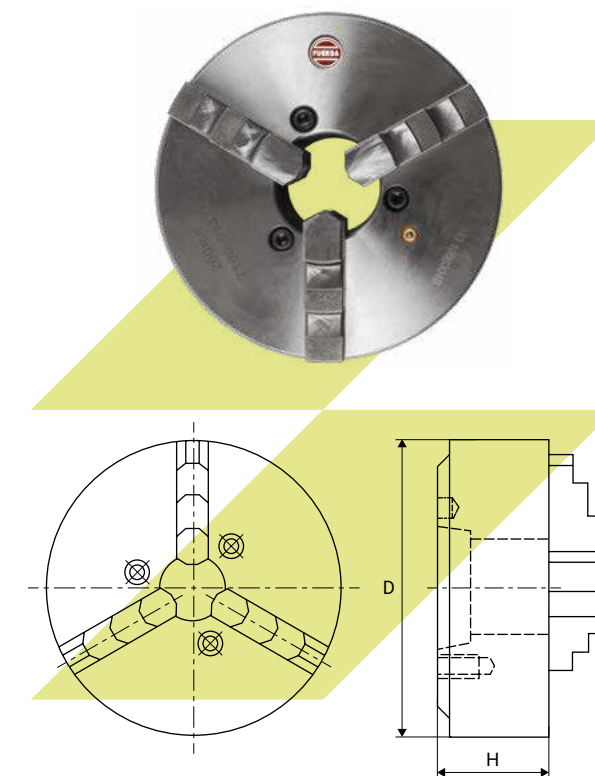

Производитель: FUERDA

Артикул	Обозначение по ГОСТ	D, мм	H, мм	Размер конуса	Масса, кг
1416019	7100-0033	200	75	6	17
1262968	7100-0035	250	85	6	31
1262970	7100-0041	315	95	8	50
1379457	7100-0043	400	105	8	90
1262972	7100-0045	400	105	11	90

Патроны токарные

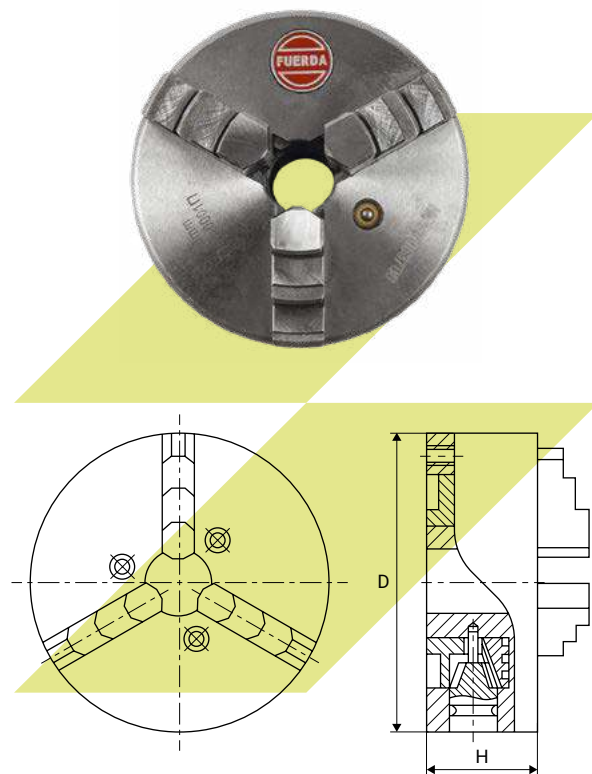

Производитель: FUERDA

Артикул	Обозначение по ГОСТ	D, мм	H, мм	Масса, кг
1416015	7100-0001	80	50	2
1416016	7100-0002	100	55	4
1416017	7100-0003	125	60	6
1326540	7100-0005	160	65	12
1416018	7100-0007	200	75	17
1262967	7100-0009	250	85	31
1262969	7100-0011	315	95	50
1262971	7100-0015	400	105	90

Кулачки обратные к патрону

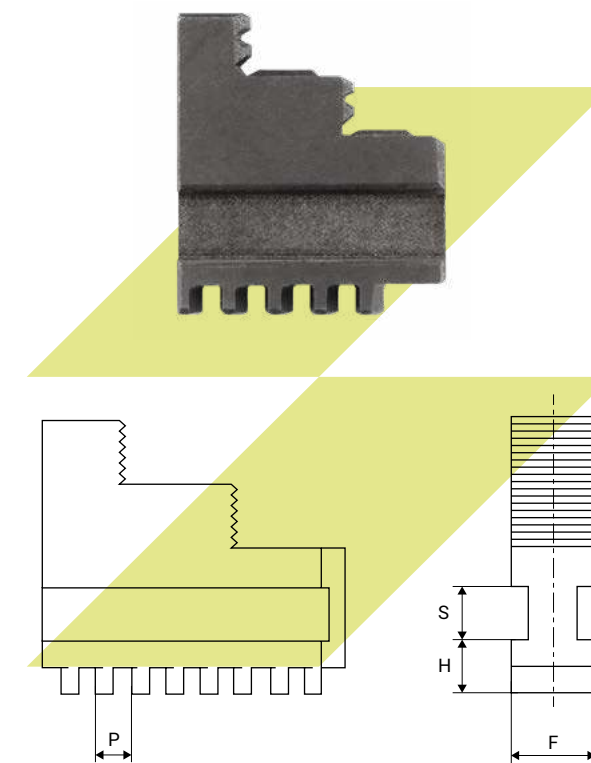

Производитель: FUERDA

Артикул	Диаметр патрона, мм	Шаг P, мм	Ширина кулачка F, мм	Высота полки H, мм	Паз S, мм
1416007	80	5	12	6	7
1416008	100	6	15	6,7	8
1416009	125	6	16	7	8
1326538	160	7	20	7	8
1416010	200	8	22	10	10
1262973	250	9	28	11,5	12
1262974	315	10	36	13	12
1262975	400	10	36	13	12

Кулачки прямые к патрону



ГОСТ
2675-80

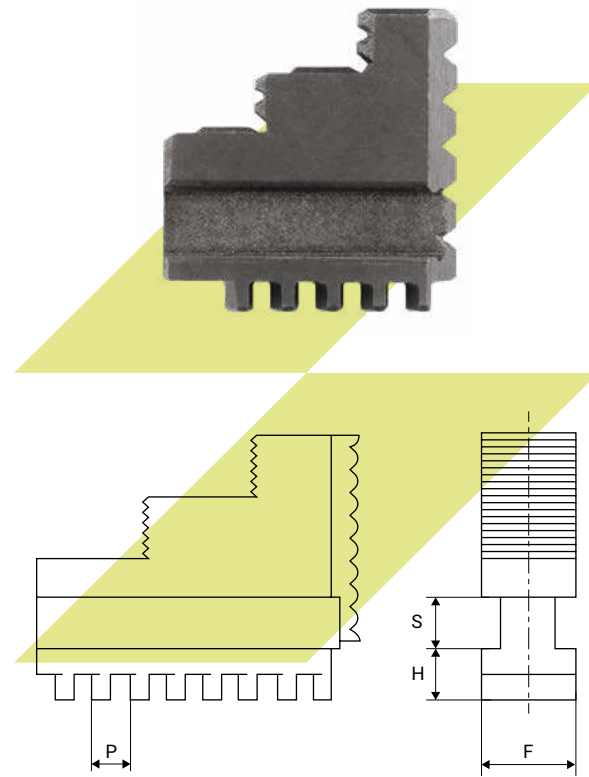

Производитель: FUERDA

Артикул	Диаметр патрона, мм	Шаг P, мм	Ширина кулачка F, мм	Высота полки H, мм	Паз S, мм
1416011	80	5	12	6	7
1416012	100	6	15	6,7	8
1416013	125	6	16	7	8
1326539	160	7	20	8	8
1416014	200	8	22	10	10
1262976	250	9	28	11,5	12
1262977	315	10	36	13	12
1262978	400	10	36	13	12

Центры станочные вращающиеся



ГОСТ 8742-75
тип А
исполнение 1

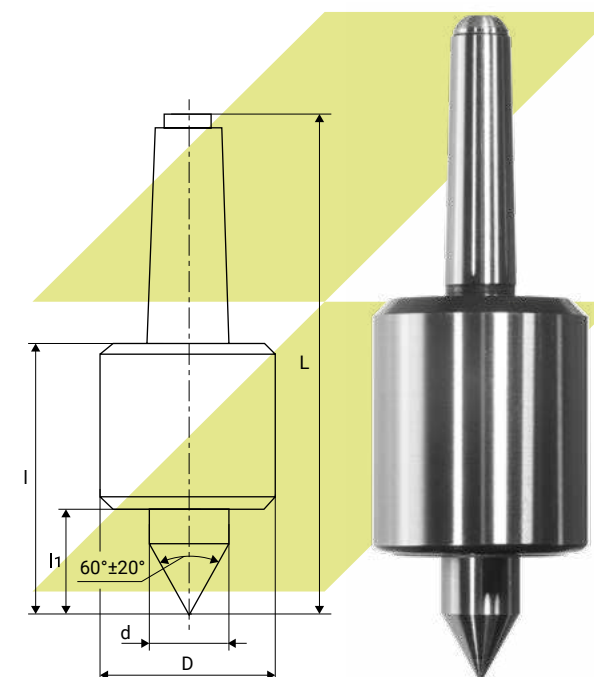

Артикул	L, мм	d, мм	D, мм	I, мм	I ₁ , мм	Хвостовик	Серия
1847443	130	-	-	-	-	KM0	Нормальная
1846884	140	-	-	-	-	KM1	Нормальная
112714	160	22	56	24	90	KM2	Нормальная
112716	180	25	63	26	94	KM3	Нормальная
1337433	190	-	-	-	-	KM3	Усиленная
112718	210	28	71	30	101	KM4	Нормальная
112720	220	36	75	36	111	KM4	Усиленная
112721	240	32	80	34	104	KM5	Нормальная
112723	250	40	90	45	114	KM5	Усиленная

Центры станочные вращающиеся



Артикул		L, мм	d, мм	D, мм	l, мм	l ₁ , мм	Хвостовик	Серия
1848034	●	160	22	56	24	90	KM2	Нормальная
1848036	●	180	25	63	26	94	KM3	Нормальная
1848038	●	190	-	-	-	-	KM3	Усиленная
1848039	●	210	28	71	30	101	KM4	Нормальная
1848040	●	220	36	75	36	111	KM4	Усиленная
1848041	●	240	32	80	34	104	KM5	Нормальная
1848045	●	250	40	90	45	114	KM5	Усиленная
1848049	●	330	-	-	-	-	KM6	Нормальная

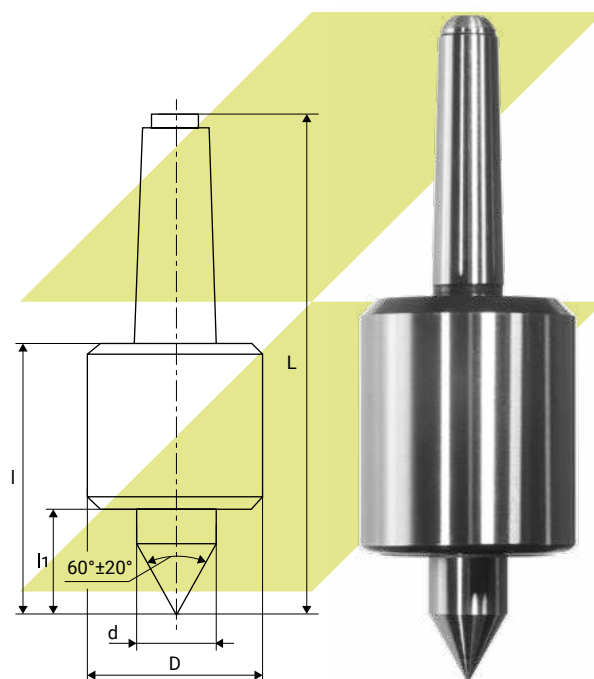

Центры станочные вращающиеся



Артикул		L, мм	d, мм	D, мм	l, мм	l ₁ , мм	Хвостовик	Серия
1847444	●	160	22	56	24	90	KM2	Нормальная
1806216	●	180	25	63	26	94	KM3	Нормальная
1243984	●	210	28	71	30	101	KM4	Усиленная
1335836	●	240	32	80	34	104	KM5	Усиленная
1275277	●	250	40	90	45	114	KM5	Нормальная

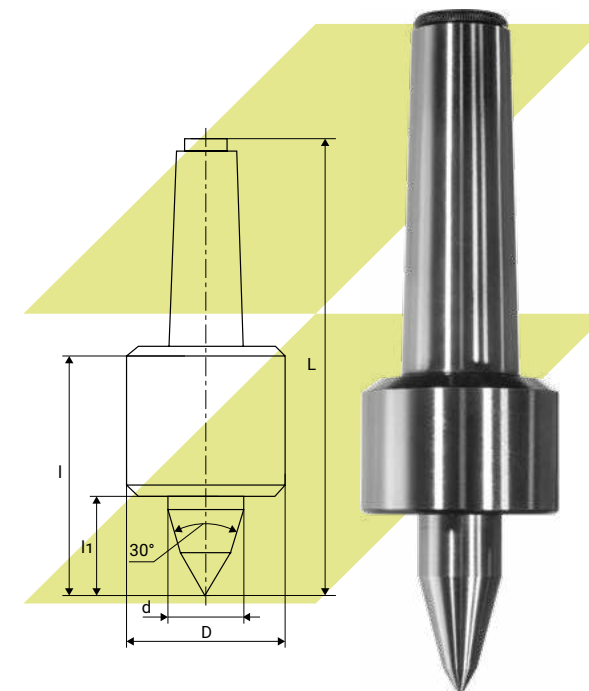

Центры станочные вращающиеся

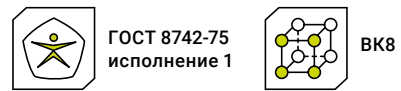

Артикул		L, мм	d, мм	D, мм	l, мм	l ₁ , мм	Хвостовик
1256433	●	160	22	56	24	90	KM2
1256434	●	180	25	63	26	94	KM3
1256435	●	210	28	71	30	101	KM4
1256436	●	240	32	80	34	104	KM5
1256437	●	330	40	90	45	114	KM6

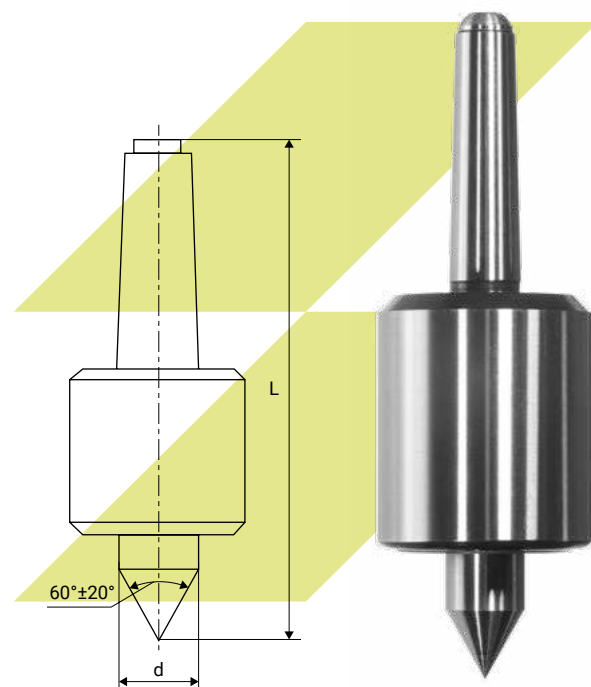

Центры станочные вращающиеся

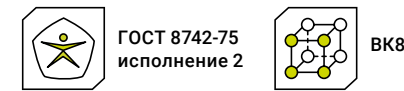

Артикул		L, мм	d, мм	D, мм	l, мм	l ₁ , мм	Хвостовик
1847445	●	160	22	56	24	90	KM2
1847446	●	180	25	63	26	94	KM3
1847448	●	210	28	71	30	101	KM4
1847449	●	240	32	80	34	104	KM5
1847451	●	330	40	90	45	114	KM6

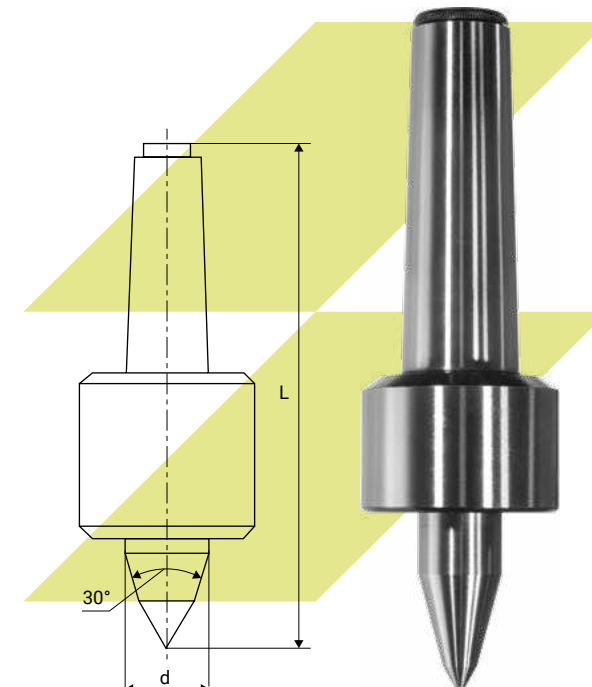

Центры вращающиеся ЧПУ



ГОСТ 8742-75
Тип А
исполнение 1

Артикул		L, мм	d, мм	D, мм	l, мм	l ₁ , мм	Хвостовик	Серия
1788978	●	225	28	71	116	30	KM4	нормальная
1107358	●	260	32	80	124	34	KM5	нормальная
1257970	●	275	40	90	139	45	KM5	усиленная

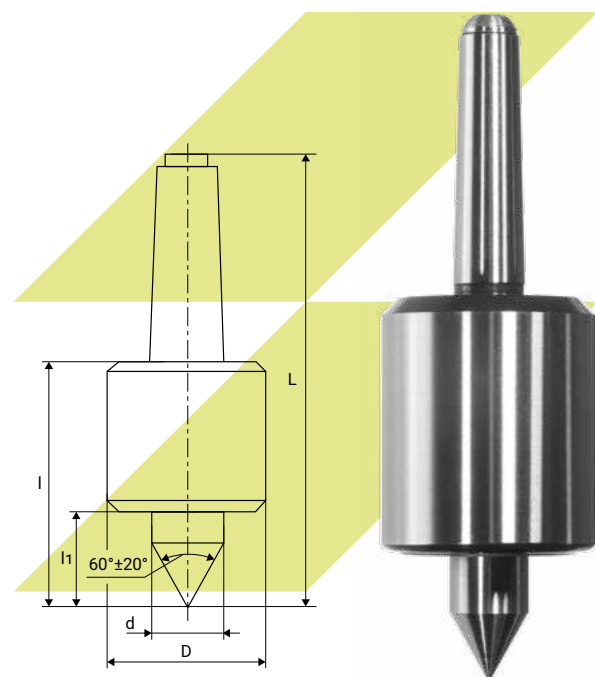

Центры вращающиеся ЧПУ



ГОСТ 8742-75
Тип А
исполнение 1

Артикул		L, мм	d, мм	D, мм	l, мм	l ₁ , мм	Хвостовик	Серия
1848042	●	260	32	80	124	34	KM5	нормальная
1848046	●	275	40	90	139	45	KM5	усиленная

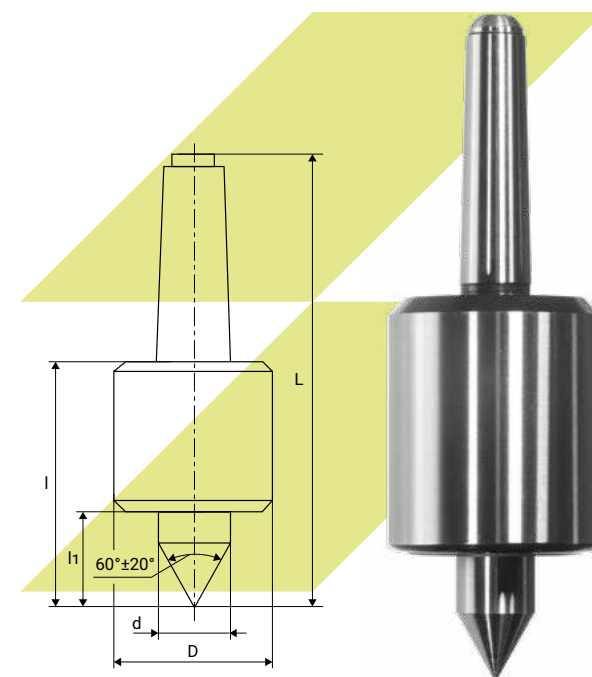

Центры вращающиеся ЧПУ



ГОСТ 8742-75
Тип А
исполнение 2

Артикул		L, мм	d, мм	D, мм	l, мм	l ₁ , мм	Хвостовик	Серия
1343019	●	185	25	63	99	26	KM3	нормальная
1847447	●	225	28	71	116	30	KM4	нормальная
1261471	●	260	32	80	124	34	KM5	нормальная
1135404	●	275	40	90	139	45	KM5	усиленная

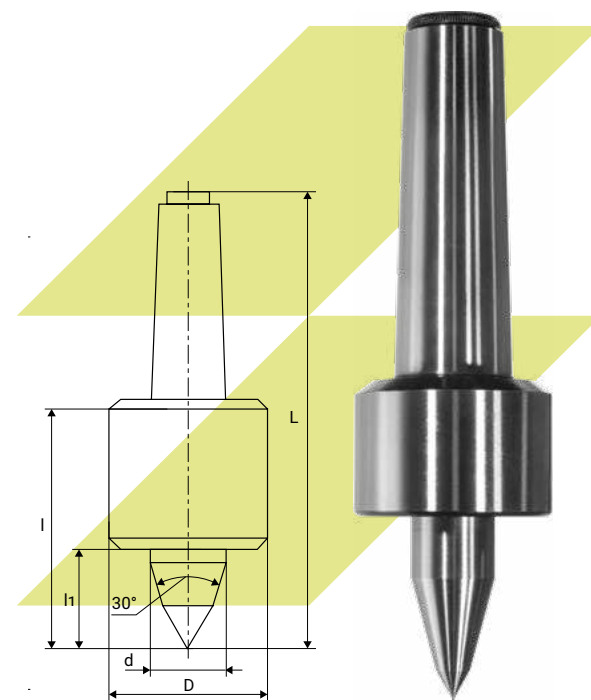

Центры вращающиеся ЧПУ



ГОСТ 8742-75
Тип А
исполнение 2

Артикул		L, мм	d, мм	D, мм	l, мм	l ₁ , мм	Хвостовик	Серия
1848044	●	260	32	80	124	34	KM5	нормальная
1848048	●	275	40	90	139	45	KM5	усиленная

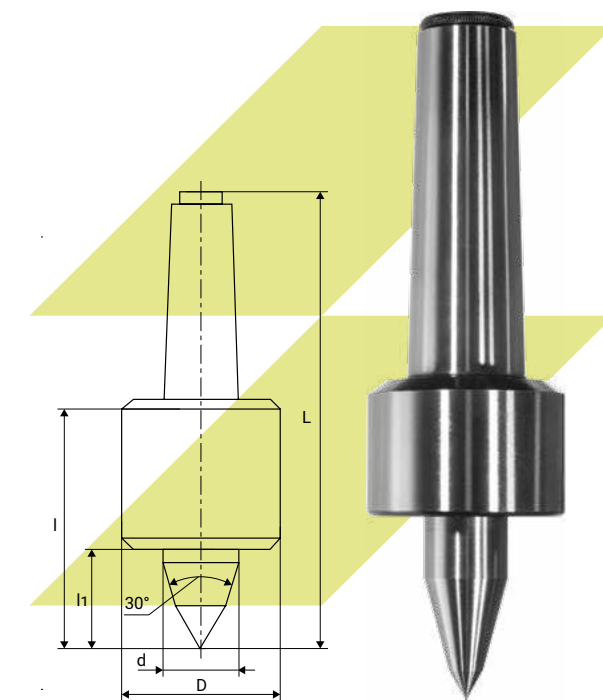

Центры вращающиеся грибовые



Артикул	Рабочий диапазон, мм	L, мм	d, мм	D, мм	l ₁ , мм	Хвостовик	Серия
1847433	25–60	160	22	56	24	KM2	нормальная
1582341	30–70	180	25	63	26	KM3	нормальная
1337434	30–70	210	28	71	30	KM4	нормальная
1591065	30–70	220	36	75	36	KM4	усиленная
1788998	40–90	220	36	75	36	KM4	усиленная
1325997	32–80	240	32	80	34	KM5	нормальная
1847434	40–90	240	32	80	34	KM5	нормальная
1129211	40–90	250	40	90	45	KM5	усиленная
1612107	90–130	250	40	90	45	KM5	усиленная
1342901	130–180	250	40	90	45	KM5	усиленная
1349169	180–240	250	40	90	45	KM5	усиленная
1847435	240–290	250	40	90	45	KM5	усиленная
1847436	290–340	250	40	90	45	KM5	усиленная
1847437	340–390	250	40	90	45	KM5	усиленная
1531001	40–90	340	56	125	56	KM6	усиленная
1788977	90–130	340	56	125	56	KM6	усиленная
1847438	130–180	340	56	125	56	KM6	усиленная
1847439	180–240	340	56	125	56	KM6	усиленная
1847440	240–290	340	56	125	56	KM6	усиленная
1847441	290–340	340	56	125	56	KM6	усиленная
1847442	340–390	340	56	125	56	KM6	усиленная

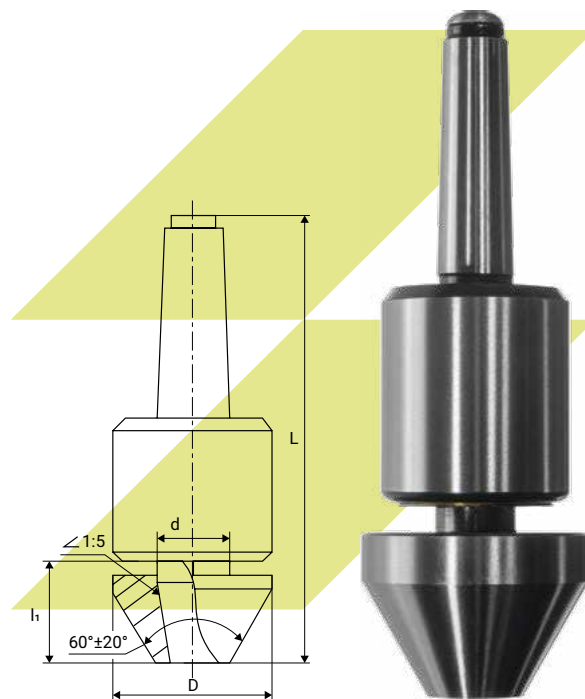

Центры вращающиеся грибовые



Артикул	Рабочий диапазон, мм	L, мм	d, мм	D, мм	l ₁ , мм	Хвостовик	Серия
1848031	32–80	240	32	80	34	KM5	нормальная
1848032	40–90	240	32	80	34	KM5	нормальная
1848033	40–90	250	40	90	45	KM5	усиленная

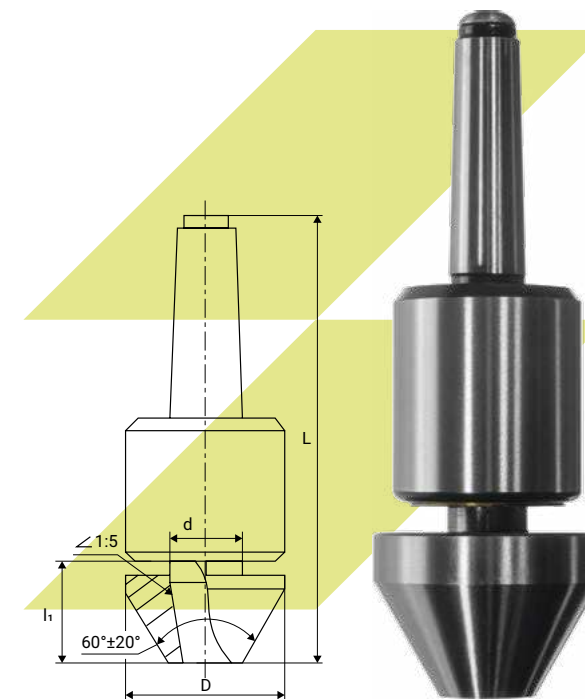

Центры упорные



ГОСТ 13214-79
исполнение 1

Артикул		Обозначение по ГОСТ	L, мм	d, мм	Хвостовик
1614341	●	7032-0013	80	12,2	KM1
1847453	●	7032-0015	90	12,2	KM1
112728	●	7032-0017	100	18,0	KM1
112729	○	7032-0019	110	18,0	KM2
112732	●	7032-0021	125	18,0	KM2
112733	●	7032-0023	125	24,1	KM3
112734	●	7032-0025	140	24,1	KM3
112736	●	7032-0027	160	24,1	KM3
1331115	●	7032-0029	160	31,6	KM4
112742	●	7032-0032	180	31,6	KM4
112746	●	7032-0035	200	44,7	KM5
112749	●	7032-0039	220	44,7	KM5
1103186	●	7032-0043	280	63,8	KM6
1103187	●	7032-0047	320	63,0	KM6

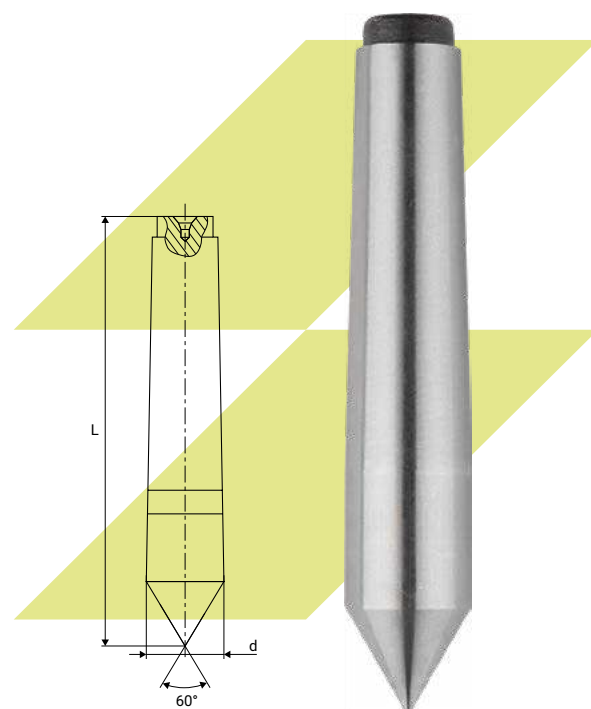

Центры упорные



ГОСТ 13214-79
исполнение 1

Артикул		Обозначение по ГОСТ	L, мм	d, мм	Хвостовик
1848052	●	7032-0013	80	12,2	KM1
1848055	●	7032-0017	100	18,0	KM1
1848056	○	7032-0019	110	18,0	KM2
1848058	●	7032-0021	125	18,0	KM2
1848060	●	7032-0023	125	24,1	KM3
1848062	●	7032-0025	140	24,1	KM3
1848064	●	7032-0027	160	24,1	KM3
1848066	●	7032-0029	160	31,6	KM4
1848068	●	7032-0032	180	31,6	KM4
1848070	●	7032-0035	200	44,7	KM5
1848072	●	7032-0039	220	44,7	KM5
1848074	●	7032-0043	280	63,8	KM6
1848076	●	7032-0047	320	63,0	KM6

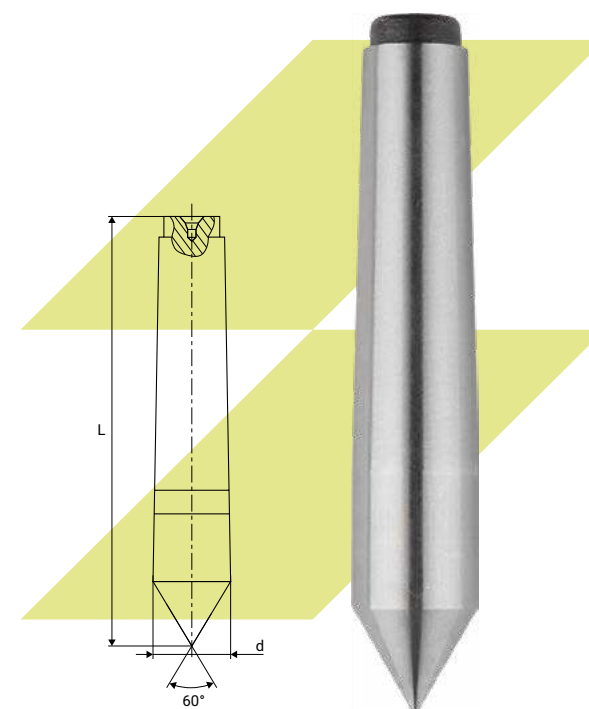

Центры упорные

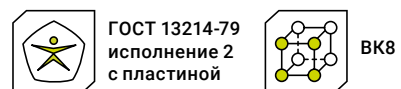

Артикул	Обозначение по ГОСТ	L, мм	D, мм	Хвостовик	№ пластины по ГОСТ 25413-82
1104415	7032-0014	80	12,2	КМ1	34090
1289468	7032-0016	90	12,2	КМ1	34090
1847454	7032-0018	100	18,0	КМ2	34110
112730	7032-0020	110	18,0	КМ2	34110
1273167	7032-0022	125	18,0	КМ2	34110
1134692	7032-0024	125	24,1	КМ3	34130
112735	7032-0026	140	24,1	КМ3	34130
1418403	7032-0028	160	24,1	КМ3	34130
112741	7032-0030	160	31,6	КМ4	34150
1289469	7032-0033	180	31,6	КМ4	34150
112747	7032-0036	200	44,7	КМ5	34170
1847455	7032-0037	200	44,7	КМ5	34190
1289470	7032-0040	220	44,7	КМ5	34170
1847456	7032-0041	220	44,7	КМ5	34190
1109316	7032-0044	280	63,8	КМ6	34190
1847457	7032-0045	280	63,8	КМ6	34210
1740239	7032-0048	320	63,8	КМ6	34190
1847458	7032-0049	320	63,8	КМ6	34210

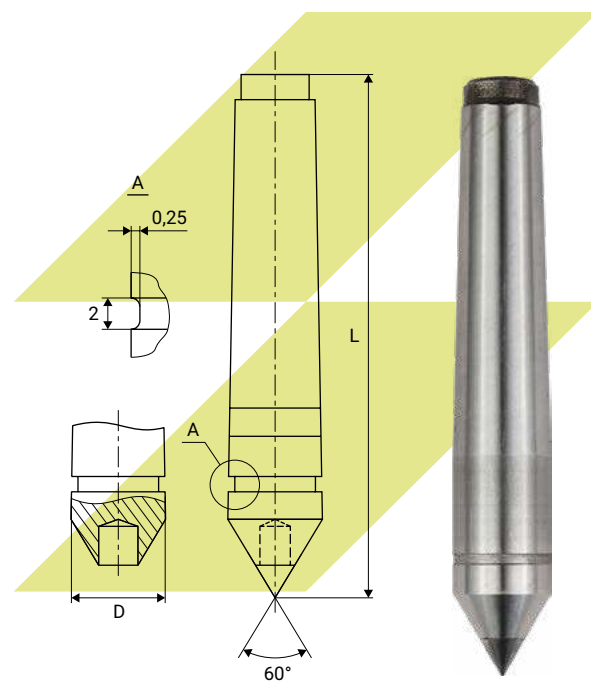

Центры упорные

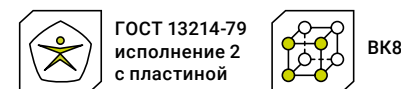

Артикул	Обозначение по ГОСТ	L, мм	D, мм	Хвостовик	№ пластины по ГОСТ 25413-82
1848053	7032-0014	80	12,2	КМ1	34090
1848054	7032-0016	90	12,2	КМ1	34090
1848057	7032-0020	110	18,0	КМ2	34110
1848059	7032-0022	125	18,0	КМ2	34110
1848061	7032-0024	125	24,1	КМ3	34130
1848063	7032-0026	140	24,1	КМ3	34130
1848065	7032-0028	160	24,1	КМ3	34130
1848067	7032-0030	160	31,6	КМ4	34150
1848069	7032-0033	180	31,6	КМ4	34150
1848071	7032-0036	200	44,7	КМ5	34170
1848073	7032-0040	220	44,7	КМ5	34170
1848075	7032-0044	280	63,8	КМ6	34190

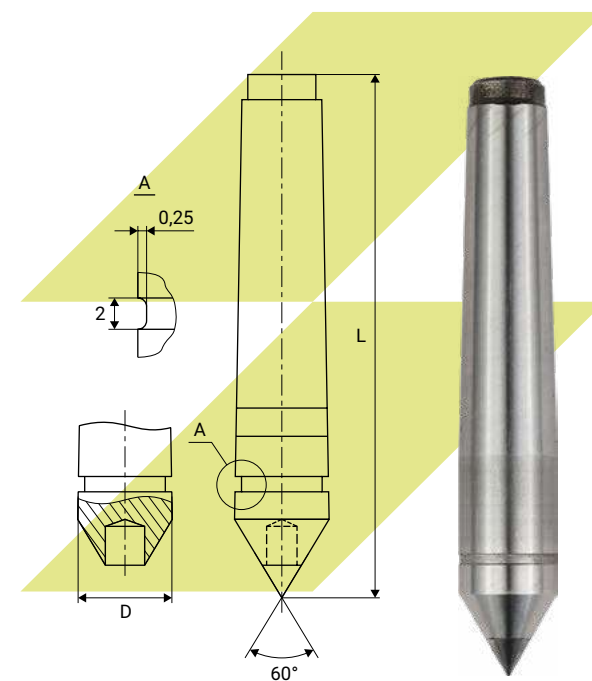

Полуцентры упорные



ГОСТ 2576-79
исполнение 1

Артикул	Обозначение по ГОСТ	L, мм	D, мм	Хвостовик
1847426	7032-0073	80	12,2	KM1
1137221	7032-0075	100	18,0	KM2
1137222	7032-0077	125	21,1	KM3
1137223	7032-0079	160	31,6	KM4
1847427	7032-0082	200	44,7	KM5

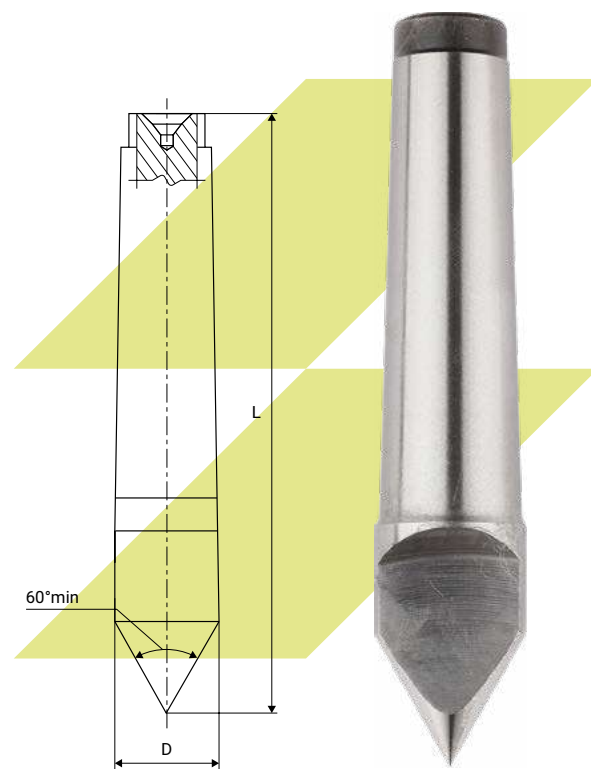

Полуцентры упорные



ГОСТ 2576-79
исполнение 1

Артикул	Обозначение по ГОСТ	L, мм	D, мм	Хвостовик
1848024	7032-0075	100	18,0	KM2
1848026	7032-0077	125	21,1	KM3
1848028	7032-0079	160	31,6	KM4

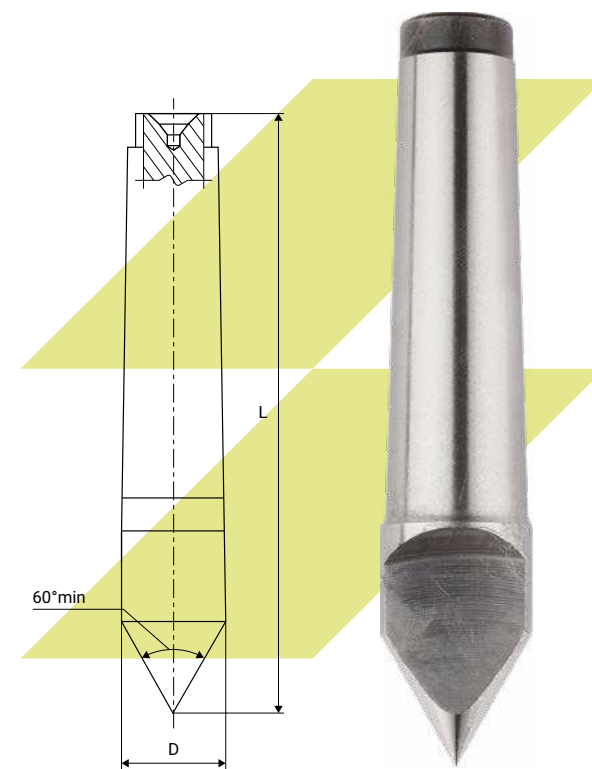

Полуцентры упорные

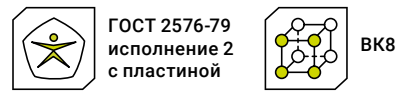

Артикул	Обозначение по ГОСТ	L, мм	D, мм	Хвостовик
1104416	7032-0074	80	12,1	KM1
1262979	7032-0076	100	17,8	KM2
1134693	7032-0078	125	23,8	KM3
1218894	7032-0080	160	31,3	KM4
1377258	7032-0083	200	44,4	KM5
1236231	7032-0086	280	63,3	KM6

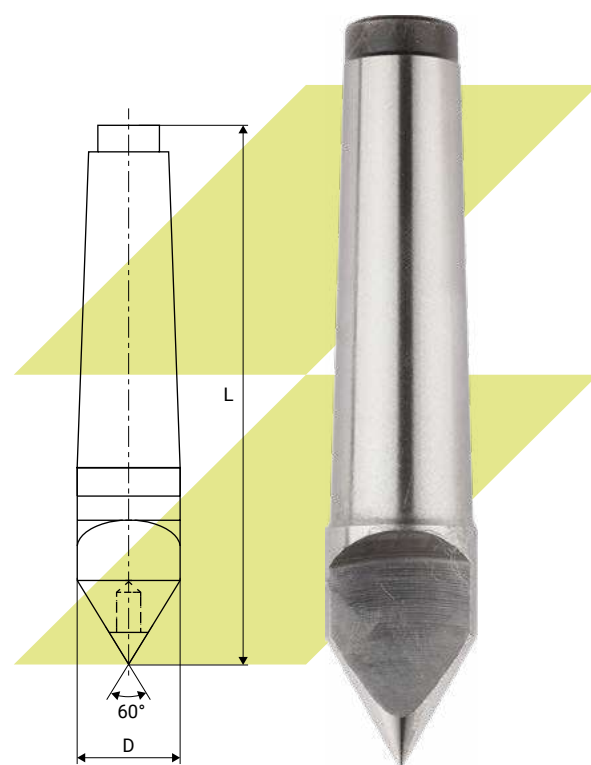

Полуцентры упорные

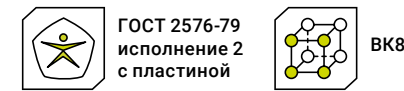

Артикул	Обозначение по ГОСТ	L, мм	D, мм	Хвостовик
1848023	7032-0074	80	12,1	KM1
1848025	7032-0076	100	17,8	KM2
1848027	7032-0078	125	23,8	KM3
1848029	7032-0080	160	31,3	KM4
1848030	7032-0083	200	44,4	KM5

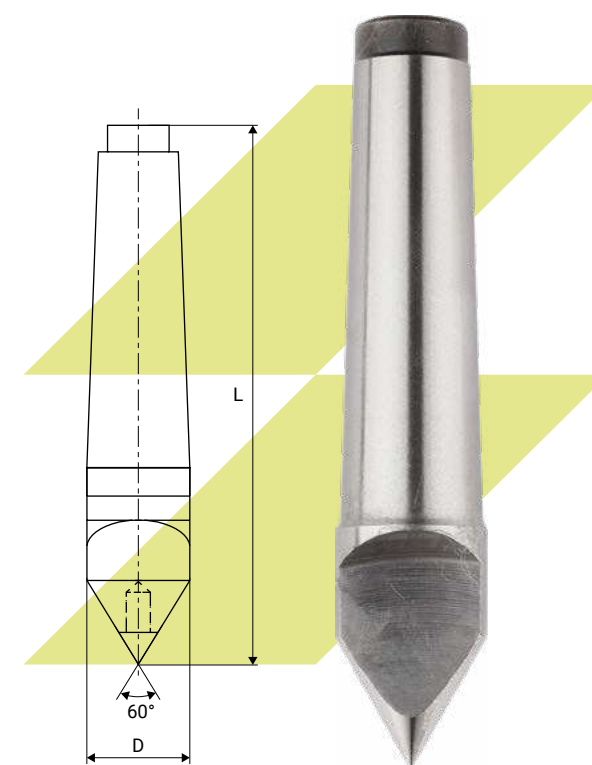

Тиски станочные неповоротные прецизионные

ТИП
3320 QGG

сталь

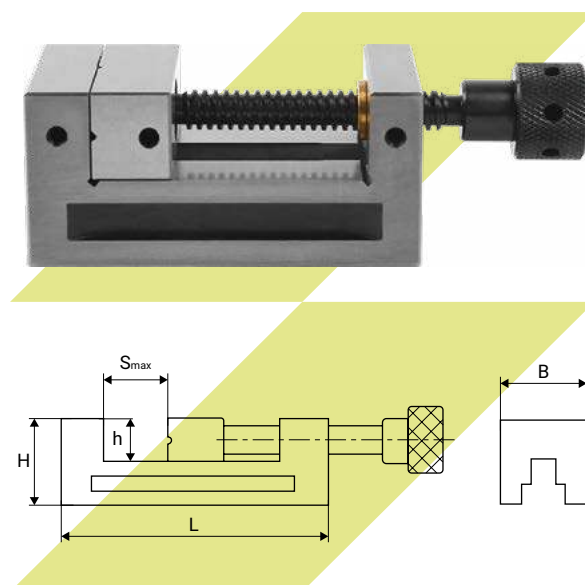

Артикул		Ширина губок В, мм	Ход S_{max} , мм	Высота Н, мм	Общая длина L, мм	Масса, кг
1417314	○	60	55	60	110	2,4
1417315	●	63	85	63	190	3,8
1417316	○	73	100	74	210	5,0
1417317	●	80	100	84	220	6,5
1417318	●	100	125	95	260	13,0
1417319	○	125	160	110	300	19,5

Стол поворотный горизонтально-вертикальный круглый, серия TSL

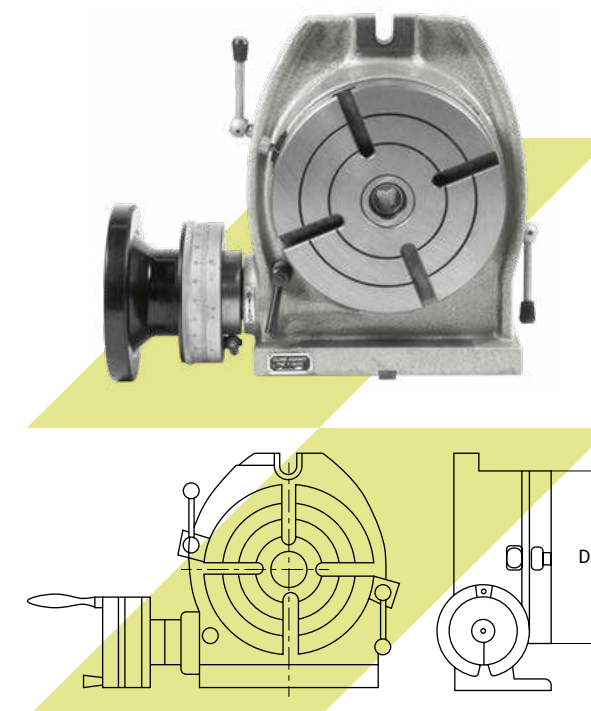

Артикул		Диаметр D, мм	Диаметр рекомендованного токарного патрона, мм	Конусность центровочного отверстия	Масса, кг
1847428	○	100	80	KM2	7,0
1182510	○	160	125	KM2	23,0
1182511	○	200	160	KM3	31,5
1182512	○	250	200	KM3	46,0
1182513	○	320	250	KM4	77,0
1182514	○	400	315	KM4	150,0
1847429	○	800	630	KM6	1150,0

Стол поворотный горизонтальный круглый, серия TS

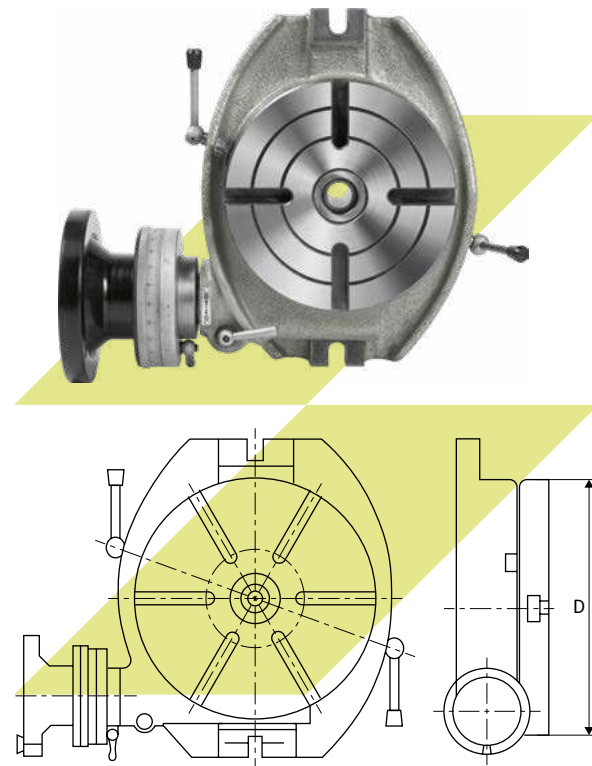

Артикул	Диаметр D, мм	Диаметр рекомендованного токарного патрона, мм	Конусность центровочного отверстия	Масса, кг
1182505	160	125	KM2	16,5
1182506	200	160	KM3	22,5
1182507	250	200	KM3	33,5
1182508	320	250	KM4	65,0
1847430	500	400	KM5	215,0
1182509	400	315	KM4	125,0
1419448	630	500	KM5	345,0
1847431	800	630	KM6	800,0

Стол поворотный наклоняемый круглый, серия TSK

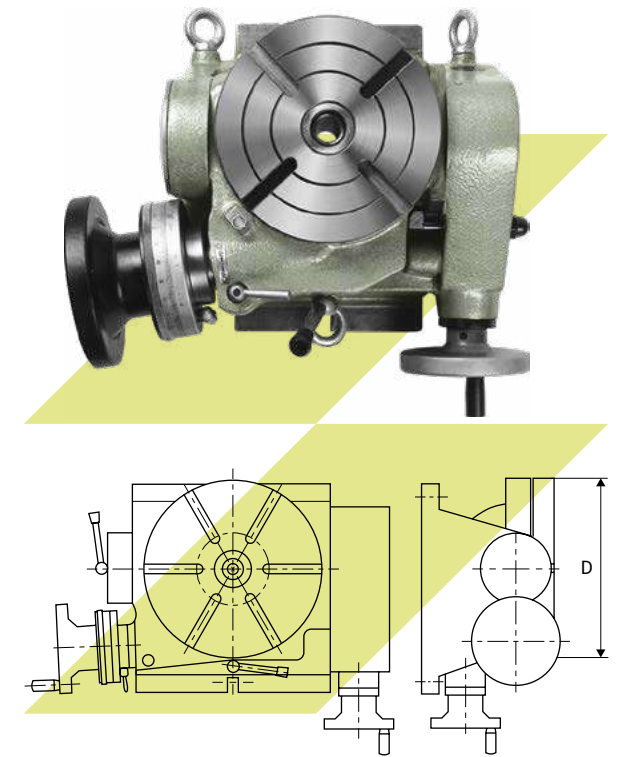

Артикул	Диаметр D, мм	Диаметр рекомендованного токарного патрона, мм	Конусность центровочного отверстия	Угол наклона	Масса, кг
1182515	160	125	KM2	0°–90°	36
1182516	200	160	KM3	0°–90°	57
1182517	250	200	KM3	0°–90°	80
1182518	320	250	KM4	0°–90°	135
1182519	400	315	KM4	0°–90°	280
1847432	500	400	KM4	0°–90°	350

Универсальные делительные головки

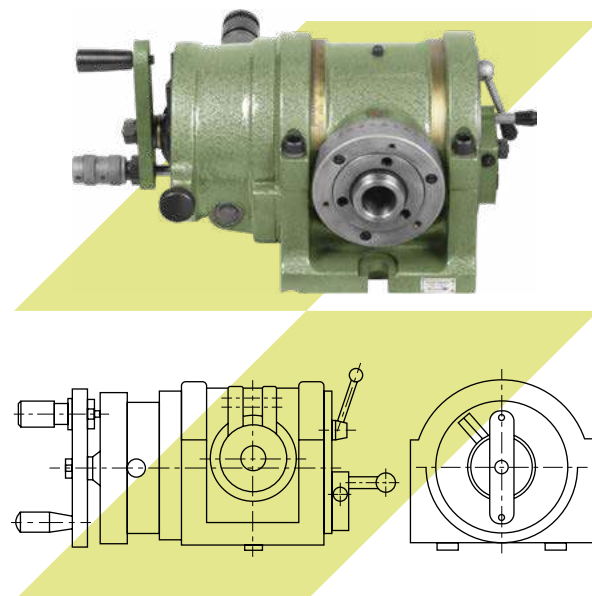

Артикул	Обозначение	ØD, мм	Ø токарного патрона, мм	Максимальная нагрузка на подшипник, кг	Конус шпиндельного отверстия	Минимальная градуировка шкалы	Передаточное отношение	Вес, кг
1182499	FB80	160	100	80	KM3	10"	1:40	26,0
1182500	F12100	200	125	100	KM3	10"	1:40	57,0
1182501	F12125	250	160	130	KM4	10"	1:40	83,5
1182502	F12160	320	200	130	KM4	10"	1:40	100,0
1182503	F12200	400	250	200	KM5	10"	1:40	265,0
1182504	F12250	500	320	200	KM5	10"	1:40	334,0

Универсальные делительные головки с дополнительной комплектацией

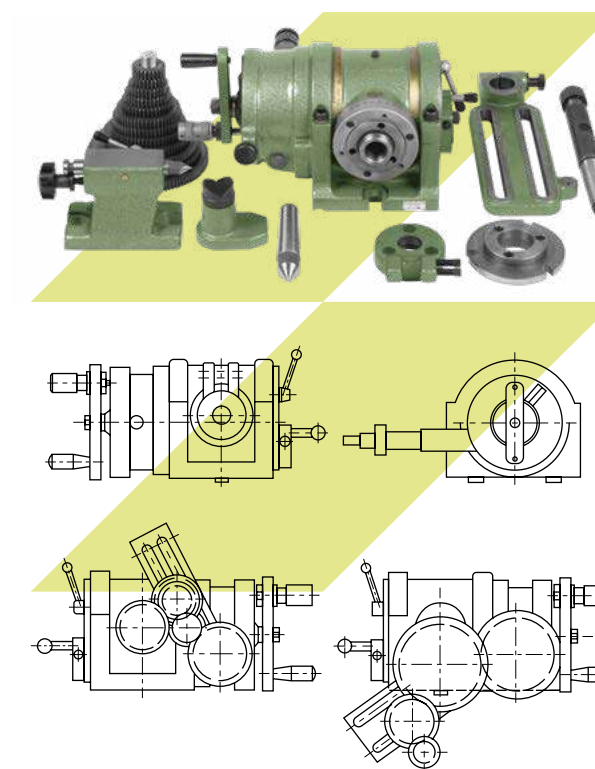

Артикул	Обозначение	ØD, мм	Диаметр токарного патрона, мм	Максимальная нагрузка на подшипник, кг	Конус шпиндельного отверстия	Минимальная градуировка шкалы	Передаточное отношение	Вес, кг
1182494	FW80	160	100	80	KM3	10"	1:40	36
1182495	F11100A	200	125	100	KM3	10"	1:40	67
1182496	F11125A	250	160	130	KM4	10"	1:40	110
1182497	F11160A	320	200	130	KM4	10"	1:40	130
1182498	F11200A	400	200	130	KM4	10"	1:40	135



Измерительный инструмент

Штангенциркули	736
Нутромеры индикаторные	739
Угольники	741
Линейки измерительные	743
Меры длины	744
Проволочки мерительные	753
Шаблоны	756
Щупы	758

Штангенциркули

Штангенциркули нониусные используются для наружных и внутренних измерительных и разметочных работ с высокой точностью. Выполнены из прочной и жесткой стали, которая обеспечивает минимальную погрешность при измерениях. Инструмент имеет матовое покрытие для защиты от бликов. Рама с фиксирующим винтом из нержавеющей стали гарантирует долгий срок службы. Обладают прочными губками и оснащены высокоточной нониусной системой измерений. Измерительный блок имеет хорошую эргономику.



Нутромеры индикаторные

Индикаторные нутромеры предназначены для определения размеров пазов, отверстий и внутренних поверхностей изделий методами абсолютного или относительного измерения. Удобная рукоятка с теплоизолирующей втулкой снижает влияние на инструмент тепла от рук оператора, обеспечивая высокую точность измерений. Измерительные наконечники изготовлены из твердого сплава, что увеличивает срок службы инструмента в условиях большого количества измерений.



Угольники УШ поверочные

Поверочные угольники предназначены для измерений отклонений от перпендикулярности рабочих поверхностей средств измерений. Выполнены из прочной стали. Конструкция имеет четкий прямой угол. Широкое основание обеспечивает устойчивость.



Линейки измерительные

Цельнометаллические линейки предназначены для измерения линейных размеров. Обеспечивают высокую точность измерений даже при наличии небольших неровностей или кривизны детали. Применяются при выполнении строительных и ремонтных работ. Выполнены из прочной стали, устойчивой к продолжительным деформациям, и обладают пружинящим эффектом. Шкала с крупными цифрами нанесена с обеих сторон линейки.



Меры длины

Меры длины предназначены для использования в качестве рабочей меры для регулировки и настройки показывающих измерительных приборов и для непосредственного измерения линейных размеров промышленных изделий. Прочные металлические изделия не подвержены износу и имеют длительный срок службы.



Проволочки мерительные

Мерительные проволочки используются при определении среднего диаметра наружной резьбы. Изделия также подойдут для измерения ширины впадин на шлицевых валах и втулках с эвольвентным профилем. Применимы для контроля толщины зубьев.



Шаблоны

Шаблоны представляют собой набор пластин с эталонными зубцами. Помогают выявить износ оборудования. Шаблоны позволяют осуществить измерение методом подбора подходящего щупа и прикладыванием к поверхности. Конструкция позволяет свободно перемещать эталоны, а также доставать их из веера в случае необходимости. Пластины изготовлены из твердого сплава, отличаются долговечностью и устойчивостью к коррозии.



Щупы

Щупы предназначены для точной настройки ширины зазоров между деталями и различными плоскостями. Изготовлены из прочной стали и отличаются высокой стойкостью к износу и долгим сроком службы.



Условные обозначения

Вид

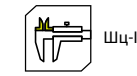

Шц-I



Индикаторные

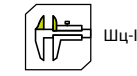

Шц-II



Широкое основание

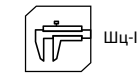

Шц-III



Обозначение стандарта



Обозначение инструментального материала

Наличие инструмента

● На складе в Нижнем Новгороде

○ Под заказ

Штангенциркули

	Нониусные двусторонние с глубиномером	Нониусные двусторонние	Нониусные односторонние
Тип	Шц-I	Шц-II	Шц-III
Стандарт	ГОСТ 166-89	ГОСТ 166-89	ГОСТ 166-89
Страница	736	737	738
			

Нутромеры

	Индикаторные
Тип	Индикаторные
Стандарт	ГОСТ 868-82
Страница	739
	

Угольники

	Поверочные
Тип	УШ
Стандарт	ГОСТ 3749-77
Страница	741
	

Линейки

	Измерительные
Стандарт	ГОСТ 427-75
Страница	743
	

Меры длины

Вид	Концевые		Плоского угла	
	Плоскопараллельные	Плоскопараллельные	Призматические	Призматические
Стандарт	ГОСТ 9038-90	ГОСТ 9038-90	ГОСТ 2875-88	ГОСТ 2875-88
Материал	Сталь	Сталь, твердый сплав	Сталь	Сталь
Комплектация	Шт	Набор	Шт	Набор
Страница	744	747	750	752
				

Проволочки мерительные

	Мерительные
Стандарт	ГОСТ 2475-88
Страница	753
	

Шаблоны

	Радиусные	Резьбовые
Стандарт	ТУ 2-034-228-87	ТУ 2-034-228-87
Страница	756	757
		

Щупы

	Щупы
Стандарт	ТУ 2-034-225-87
Страница	758
	

Штангенциркули нониусные двусторонние с глубиномером



ГОСТ 166-89

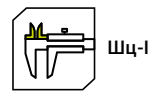

Шц-I

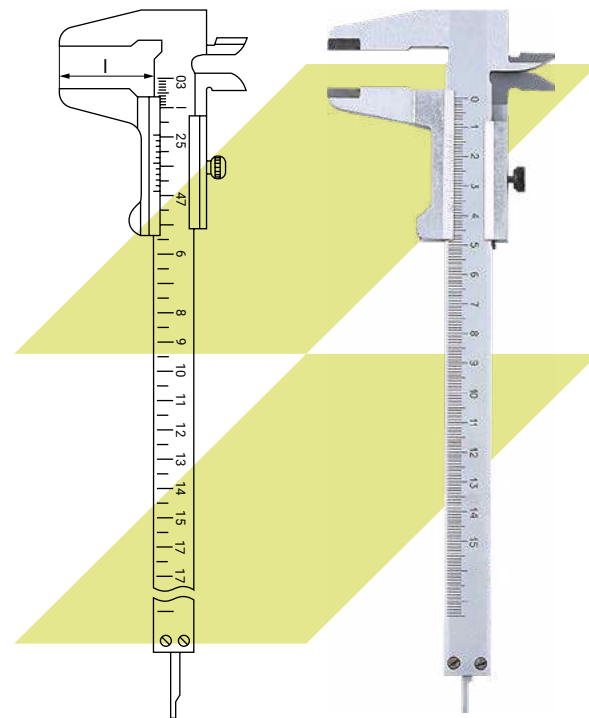

Штангенциркули нониусные двусторонние



ГОСТ 166-89

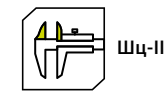

Шц-II

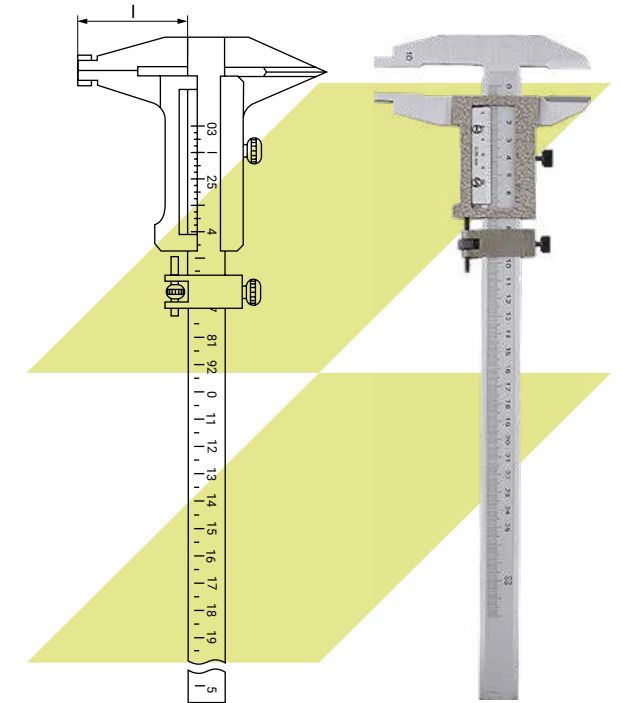

Артикул		Диапазон измерения, мм	Цена деления, мм	Погрешность (класс точности), мм	Вылет губок, мм	Внесен в Государственный реестр средств измерений
1584910	○	0-125	0,05	до 0,10	40	
1179432 *	●	0-125	0,05	0,05	40	+
1150259	○	0-125	0,10	до 0,15	40	
1425403 *	●	0-125	0,10	кл. 1	40	+
1177011 *	○	0-125	0,10	кл. 2	40	+
1480643	○	0-150	0,05	до 0,10	40	
1480645 *	●	0-150	0,05	0,05	40	+
1480646	○	0-150	0,10	до 0,15	40	
1518061 *	●	0-150	0,10	кл. 1	40	+

Артикул		Диапазон измерения, мм	Цена деления, мм	Погрешность (класс точности), мм	Вылет губок, мм	Наличие глубиномера	Внесен в Государственный реестр средств измерений
1102613	●	0-250	0,05	0,05	60		+
1323696	○	0-250	0,05	кл. 1	60	+	+
1102614	○	0-250	0,10	до 0,15	60		
1417847	○	0-250	0,10	кл. 1	60	+	
1109209	○	0-250	0,10	кл. 1	60	+	+
1583881	○	0-250	0,10	кл. 1	60		+
1416989	○	0-250	0,10	кл. 2	60		+

Штангенциркули нониусные односторонние

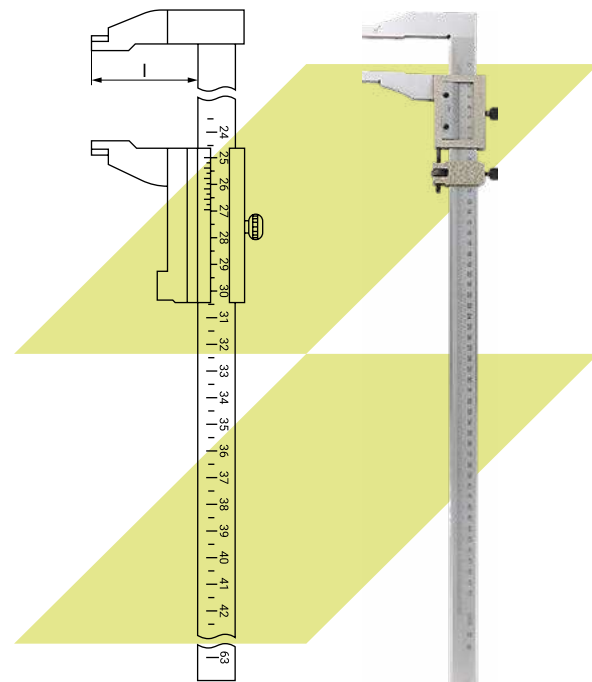
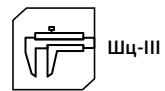

Артикул		Диапазон измерения, мм	Цена деления, мм	Погрешность (класс точности), мм	Вылет губок, мм	Внесен в Государственный реестр средств измерений
1377084		0–400	0,10	до 0,15	80	
1416990		0–400	0,10	до 0,10	80	+
1254169		0–500	0,05	до 0,15	80	
1254170		0–500	0,10	до 0,15	80	
1416386		0–500	0,10	до 0,10	80	+
1254171		250–630	0,10	до 0,15	80	
1416992		250–630	0,10	до 0,10	80	+
1105708		250–800	0,10	до 0,15	80	
1416387		250–800	0,10	до 0,10	80	+
1102689		320–1000	0,05	до 0,15	80	
1416994		320–1000	0,10	до 0,10	80	+
1102684		320–1000	0,10	до 0,15	80	

Нутромеры индикаторные

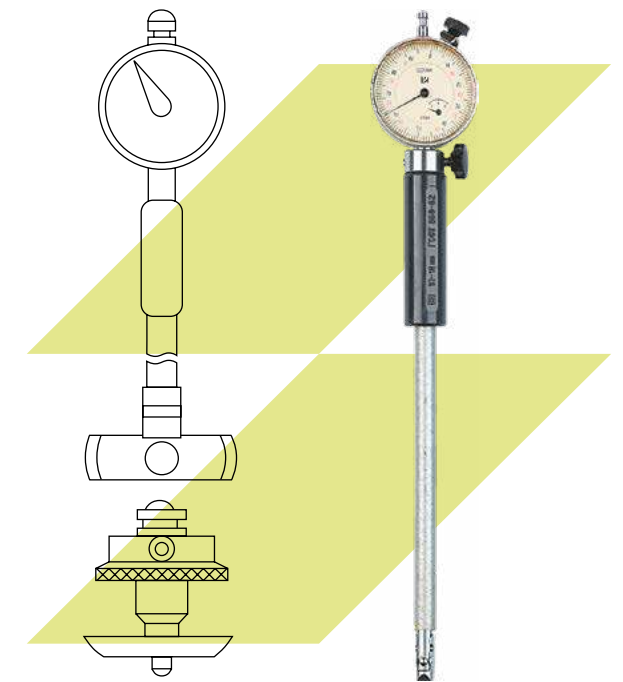

Артикул		Диапазон измерения, мм	Класс точности	Индикатор в комплекте	Класс точности индикатора
1846890		6–10	1	ИЧ-02	1
104005		6–10	2	ИЧ-02	0
104006		6–10	2	ИЧ-02	1
1846889		10–18	1	ИЧ-02	1
104011		10–18	2	ИЧ-02	0
104012		10–18	2	ИЧ-02	1
1479499		18–50	1	ИЧ-10	1
104021		18–50	2	ИЧ-10	0
104020		18–50	2	ИЧ-10	1
1376334		50–100	2	ИЧ-05	1
104025		50–100	2	ИЧ-10	0
115986		50–100	2	ИЧ-10	1

Артикул		Диапазон измерения, мм	Класс точности	Индикатор в комплекте	Класс точности индикатора
104027	○	100–160	2	ИЧ-10	1
104028	○	160–250	1	ИЧ-10	1
1585428	○	160–250	2	ИЧ-10	1
104030	○	250–450	2	ИЧ-10	0
104031	○	250–450	2	ИЧ-10	1
104032	○	450–700	2	ИЧ-10	1
1236542	○	700–1000	2	ИЧ-10	1

Угольники поверочные



ГОСТ 3749-77



УШ

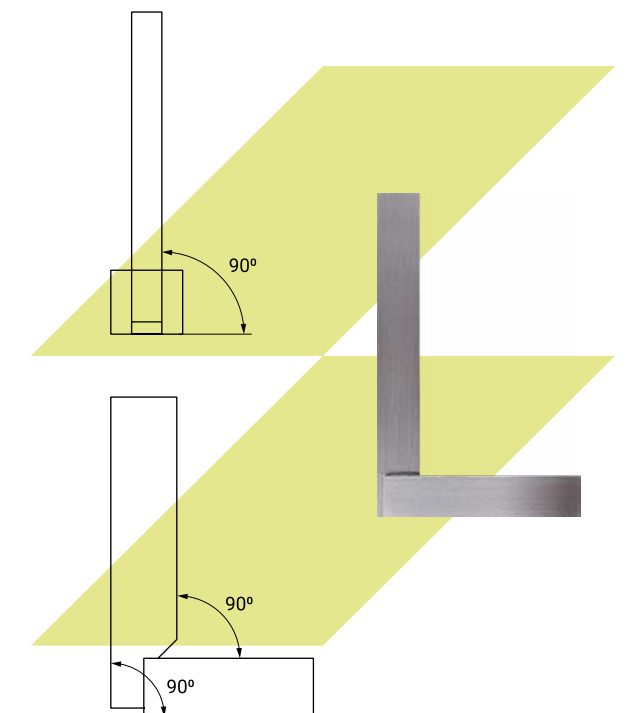

Артикул		Размер	Класс точности	Угол, градусы	Внесен в Государственный реестр средств измерений
1377082	○	100 × 60	2	90	
109081	○	100 × 60	1	90	
1377696	○	100 × 60	1	90	+
1110342	○	160 × 100	1	90	
1377697	○	160 × 100	1	90	+
115558	○	160 × 100	2	90	
1377698	○	160 × 100	2	90	+
1103244	○	250 × 160	1	90	
1377699	○	250 × 160	1	90	+
109085	○	250 × 160	2	90	
1377700	○	250 × 160	2	90	+
1103245	○	400 × 250	1	90	

Артикул		Размер	Класс точности	Угол, градусы	Внесен в Государственный реестр средств измерений
1377701	○	400 × 250	1	90	+
1377083	○	400 × 250	2	90	
1377702	○	400 × 250	2	90	+
1103246	○	630 × 400	1	90	
1377703	○	630 × 400	1	90	+
109087	○	630 × 400	2	90	
1851614	○	630 × 400	2	90	+
109088	○	1000 × 630	1	90	
1377704	○	1000 × 630	1	90	+
109089	○	1000 × 630	2	90	
1377705	○	1000 × 630	2	90	+

Линейки измерительные



ГОСТ 427-75

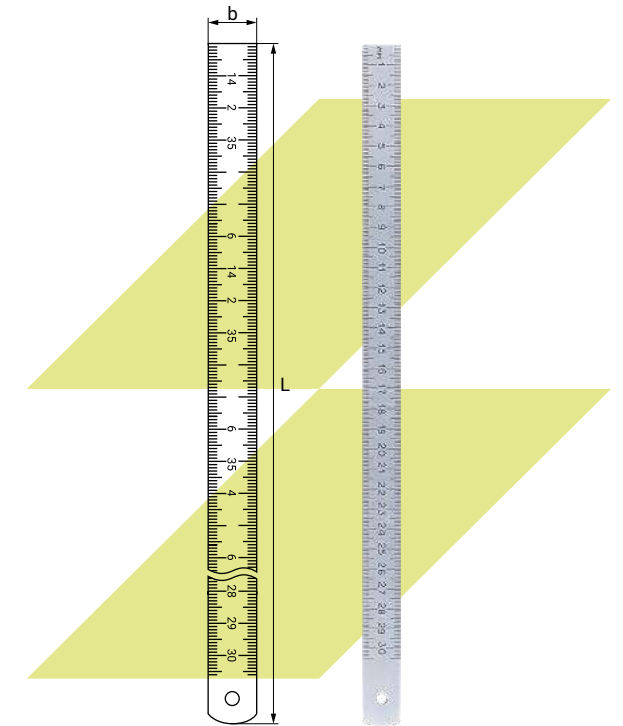

Артикул		Предел измерений, мм	L, мм	b, мм	Толщина, мм	Внесен в Государственный реестр средств измерений
113218	○	150,0	190,0	20,0	0,5	
1253852	○	150,0	340,0	20,0	0,5	+
113219	○	300,0	540,0	20,0	0,5	
1253853	○	300,0	1030,0	20,0	0,5	+
113220	○	500,0	190,0	20,0	0,5	
1253854	○	500,0	340,0	20,0	0,5	+
113221	○	1000,0	540,0	40,0	1,0	
1253855	○	1000,0	1030,0	40,0	1,0	+

Плоскопараллельные концевые меры длины



ГОСТ 9038-90



Сталь

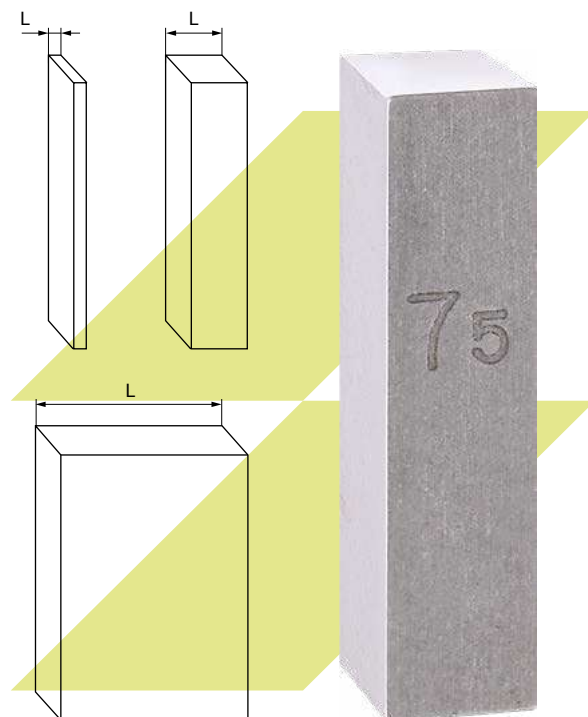

Артикул	Размер, мм	Класс точности
1335413	0,100	1
1335414	0,170	1
1335415	0,200	1
1335416	0,230	1
1335417	0,250	1
1335418	0,260	1
1335419	0,290	1
1103212	0,300	1
1103213	0,340	1
1103214	0,400	1
1103215	0,430	1
1103216	0,460	1
1276434	0,500	1
104427	0,570	1
1335420	0,700	1
1335421	0,900	1
1276435	1,000	1
1335422	1,001	1
1335423	1,003	1
1335424	1,005	1
1335425	1,006	1
1335426	1,009	1
104428	1,010	1
1276451	1,020	1
115773	1,030	1
117124	1,040	1
104429	1,050	1
1276452	1,060	1
1103217	1,070	1
1105580	1,080	1
117125	1,090	1
119379	1,100	1
117126	1,110	1
115776	1,120	1

Артикул	Размер, мм	Класс точности
119376	1,130	1
115777	1,140	1
115778	1,150	1
1276453	1,160	1
1276454	1,170	1
117127	1,180	1
1276455	1,190	1
1103218	1,200	1
1107959	1,210	1
1107960	1,220	1
1103219	1,230	1
1276456	1,240	1
104430	1,250	1
1276457	1,260	1
1103220	1,270	1
1103221	1,280	1
117128	1,290	1
1103222	1,300	1
117129	1,310	1
1107961	1,320	1
119370	1,330	1
1102585	1,340	1
1276458	1,350	1
119381	1,360	1
119371	1,370	1
117130	1,380	1
117131	1,390	1
1105581	1,400	1
1107962	1,410	1
115785	1,420	1
117132	1,430	1
1107963	1,440	1
104431	1,450	1
1107964	1,460	1
117133	1,470	1
115787	1,480	1
1103223	1,490	1
1103224	1,500	1
104432	1,600	1

Артикул	Размер, мм	Класс точности
104433	1,700	1
104434	1,800	1
104435	1,900	1
115790	2,000	1
1335427	2,001	1
1335428	2,002	1
1335429	2,003	1
1335430	2,006	1
1335431	2,007	1
1335432	2,008	1
115795	2,500	1
115791	3,000	1
1103225	3,500	1
104436	4,000	1
1276436	4,500	1
1276437	5,000	1
1335433	5,120	1
104437	5,500	1
1110104	6,000	1
104438	6,500	1
104439	7,000	1
104440	7,500	1
1102583	8,000	1
1102584	8,500	1
1276438	9,000	1
104441	9,000	2
104442	9,500	1
1276439	10,000	1
104443	10,000	2
1335434	10,240	1
1276440	14,000	1
1335435	15,360	1
1276441	20,000	1
104444	20,000	2
1335436	21,500	1
1276442	24,000	1
1276443	25,000	1
1276444	30,000	1
1335437	30,120	1

Артикул		Размер, мм	Класс точности
1335438	○	35,240	1
1276445	○	40,000	1
1335439	○	40,360	1
1335440	○	46,500	1
1276446	○	50,000	1
1276447	○	60,000	1
1335441	○	60,240	1
1335442	○	65,360	1
1335443	○	70,000	1
1335444	○	71,500	1

Артикул		Размер, мм	Класс точности
1335445	○	75,000	1
1276448	○	80,000	1
1335446	○	85,240	1
1276449	○	90,000	1
1335447	○	90,360	1
1335448	○	96,500	1
1276450	○	100,000	1
1477035	○	150,000	1

Наборы плоскопараллельных концевых мер длины



ГОСТ 9038-90

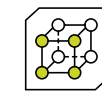

Сталь

Артикул		Обозначение	Комплекта-ция, кол-во мер	Класс точности
103674	○	№ 1	83	0
103675	○	№ 1	83	1
103676	○	№ 1	83	2
103677	○	№ 1	83	3
103678	○	№ 2	38	1
103679	○	№ 2	38	2
103680	○	№ 2	38	3
103681	○	№ 3	112	0
103682	○	№ 3	112	1
103684	○	№ 3	112	2
103685	○	№ 3	112	3
103686	○	№ 4	11	1
103687	○	№ 4	11	2
103688	○	№ 5	11	1
103689	○	№ 5	11	2
1171095	○	№ 6	11	0
103690	○	№ 6	11	1
1110349	○	№ 6	11	2
103691	○	№ 7	11	1
1639803	○	№ 7	11	2
1417616	○	№ 8	10	1
103693	○	№ 8	10	2
103694	○	№ 9	12	2
1265620	○	№ 9	12	3
103696	○	№ 10	20	1
103695	○	№ 10	20	2
103698	○	№ 10	20	3
103699	○	№ 11	43	1
1128860	○	№ 11	43	2
1128861	○	№ 11	43	3
1135211	○	№ 14	38	1
1417687	○	№ 16	19	1
103700	○	№ 19	2	1
103701	○	№ 20	23	1



Артикул	Обозначение	Комплекта- ция, кол-во мер	Класс точности
103702	№ 20	23	2
103703	№ 21	20	1

Артикул	Обозначение	Комплекта- ция, кол-во мер	Класс точности
103704	№ 21	20	2
103705	№ 22	7	3

Наборы плоскопараллельных концевых мер длины



ГОСТ 9038-90



Твердый сплав

Артикул	Обозначение	Комплекта- ция, кол-во мер	Класс точности
1132046	№ 1	83	1
1185811	№ 1	83	2
103683	№ 3	112	1
1729355	№ 6	11	1
103692	№ 7	11	1
1774448	№ 8	4	1
1177358	№ 16	19	1



Призматические меры плоского угла

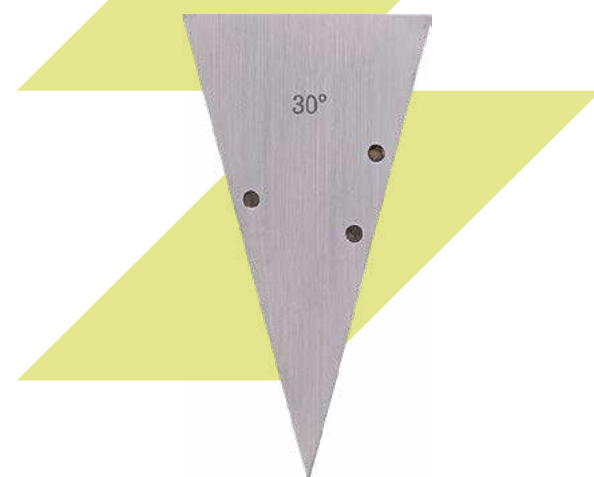
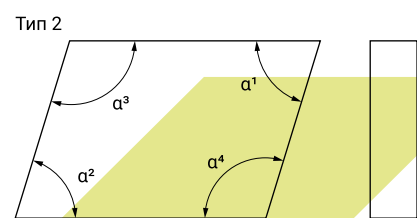
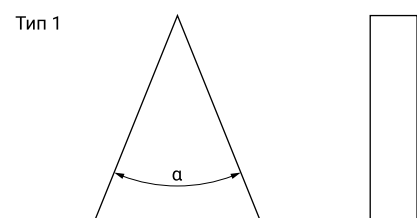

Артикул		Размер	Тип	Класс точности
1612639	○	10°	2	1
1612640	○	11°	2	1
1612641	○	12°	2	1
1612642	○	13°	2	1
1612643	○	14°	2	1
1612644	○	15°	2	1
1612645	○	15°01'	2	1
1612646	○	15°02'	2	1
1612647	○	15°03'	2	1
1612648	○	15°04'	2	1
1612649	○	15°05'	2	1
1612650	○	15°06'	2	1
1612651	○	15°07'	2	1
1612652	○	15°08'	2	1
1612653	○	15°09'	2	1
1612654	○	15°10'	2	1
1612655	○	15°20'	2	1
1612656	○	15°30'	2	1
1612657	○	15°40'	2	1
1612658	○	15°50'	2	1
1612659	○	16°	2	1
1612660	○	17°	2	1
1612661	○	18°	2	1
1612662	○	19°	2	1
1612663	○	20°	2	1
1612664	○	21°	2	1
1612665	○	22°	2	1
1612666	○	23°	2	1
1612667	○	24°	2	1
1612668	○	25°	2	1
1612669	○	26°	2	1
1612670	○	27°	2	1
1612671	○	28°	2	1
1612672	○	29°	2	1

Артикул		Размер	Тип	Класс точности
1612673	○	30°	2	1
1612674	○	31°	2	1
1612675	○	32°	2	1
1612676	○	33°	2	1
1612677	○	34°	2	1
1612678	○	35°	2	1
1612679	○	36°	2	1
1612680	○	37°	2	1
1612681	○	38°	2	1
1612682	○	39°	2	1
1612683	○	40°	2	1
1612684	○	41°	2	1
1612685	○	42°	2	1
1612686	○	43°	2	1
1612687	○	44°	2	1
1612688	○	45°	2	1
1612689	○	46°	2	1
1612690	○	47°	2	1
1612691	○	48°	2	1
1612692	○	49°	2	1
1612693	○	50°	2	1
1612694	○	51°	2	1
1612695	○	52°	2	1
1612696	○	53°	2	1
1612697	○	54°	2	1
1612698	○	55°	2	1
1612699	○	56°	2	1
1612700	○	57°	2	1
1612701	○	58°	2	1
1612702	○	59°	2	1
1612703	○	60°	2	1
1612704	○	61°	2	1
1612705	○	62°	2	1
1612706	○	63°	2	1
1612707	○	64°	2	1
1612708	○	65°	2	1
1612709	○	66°	2	1
1612710	○	67°	2	1

Артикул		Размер	Тип	Класс точности
1612711	○	68°	2	1
1612712	○	69°	2	1
1612713	○	70°	2	1
1612714	○	71°	2	1
1612715	○	72°	2	1
1612716	○	73°	2	1
1612717	○	74°	2	1
1612718	○	75°	2	1
1612719	○	76°	2	1
1612720	○	77°	2	1
1612721	○	78°	2	1
1612722	○	79°	2	1
1612723	○	80° 81° 100° 99°	3	1
1612724	○	82° 83° 98° 97°	3	1
1612725	○	84° 85° 96° 95°	3	1
1612726	○	86° 87° 94° 93°	3	1
1612727	○	88° 89° 92° 91°	3	1
1612728	○	89°10' 89°20' 90°50' 90°40'	3	1
1612729	○	89°30' 89°40' 90°30' 90°20'	3	1
1612730	○	89°50' 89°59' 90°10' 90°01'	3	1
1612731	○	90° 90° 90° 90°	3	1

Измерительный инструмент

Измерительный инструмент

Наборы призматических мер плоского угла



Артикул	Размер	Тип	Класс точности
103706	№ 1	93 меры	1
1242064	№ 1	93 меры	2
1240310	№ 2	33 меры	1
103707	№ 2	33 меры	2
103708	№ 3	8 мер	1
103709	№ 3	8 мер	2
1241347	№ 4	8 мер	1
1128859	№ 5	24 меры	1
1240326	№ 8	—	1



Проволочки мерительные



Артикул	Тип	D, мм	Класс точности
1184247	I (гладкие)	0,115	0
1184248	I (гладкие)	0,115	1
104991	I (гладкие)	0,118	0
104992	I (гладкие)	0,118	1
1134191	I (гладкие)	0,130	0
104993	I (гладкие)	0,130	1
1151426	I (гладкие)	0,142	0
104994	I (гладкие)	0,142	1
104995	I (гладкие)	0,144	0
104996	I (гладкие)	0,144	1
1184293	I (гладкие)	0,170	0
104997	I (гладкие)	0,170	1
1135838	I (гладкие)	0,173	0
104998	I (гладкие)	0,173	1
1135794	I (гладкие)	0,201	0
104999	I (гладкие)	0,201	1
1106413	I (гладкие)	0,202	0
105000	I (гладкие)	0,202	1
1236024	I (гладкие)	0,217	1
105001	I (гладкие)	0,231	0
105002	I (гладкие)	0,231	1
1105538	I (гладкие)	0,232	1
1236025	I (гладкие)	0,260	0
105003	I (гладкие)	0,260	1
105004	I (гладкие)	0,289	0
105005	I (гладкие)	0,289	1
1425058	I (гладкие)	0,291	0
105006	I (гладкие)	0,291	1
105007	I (гладкие)	0,343	0
105008	I (гладкие)	0,343	1
1236026	I (гладкие)	0,346	0
105009	I (гладкие)	0,346	1
1139942	II (ступенчатые)	0,402	0
105010	II (ступенчатые)	0,402	1

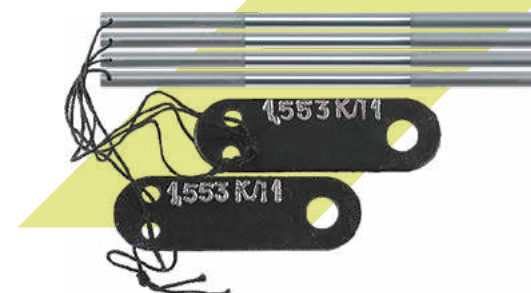
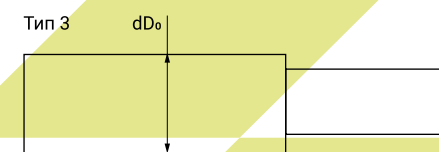
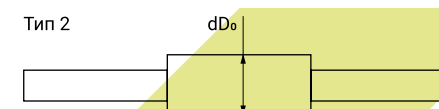
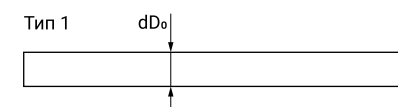

Артикул		Тип	D, мм	Класс точности
105011	○	II (ступенчатые)	0,404	0
105012	○	II (ступенчатые)	0,404	1
105013	○	II (ступенчатые)	0,433	0
105014	○	II (ступенчатые)	0,433	1
1417929	○	II (ступенчатые)	0,458	1
105015	○	II (ступенчатые)	0,461	0
105016	○	II (ступенчатые)	0,461	1
1289437	○	II (ступенчатые)	0,462	0
105017	○	II (ступенчатые)	0,462	1
105018	○	II (ступенчатые)	0,511	0
105019	○	II (ступенчатые)	0,511	1
1417930	○	II (ступенчатые)	0,524	1
105020	○	II (ступенчатые)	0,572	0
1105783	○	II (ступенчатые)	0,572	1
1103606	○	II (ступенчатые)	0,577	0
105021	○	II (ступенчатые)	0,577	1
1417931	○	II (ступенчатые)	0,611	1
105022	○	II (ступенчатые)	0,722	1
105023	○	II (ступенчатые)	0,724	1
105024	○	II (ступенчатые)	0,772	1
1289438	○	II (ступенчатые)	0,776	1
105025	○	II (ступенчатые)	0,795	1
105026	○	II (ступенчатые)	0,796	0
105027	○	II (ступенчатые)	0,796	1
105028	○	II (ступенчатые)	0,866	0
105029	○	II (ступенчатые)	0,866	1
1184363	○	II (ступенчатые)	0,895	0
105030	○	II (ступенчатые)	0,895	1
1591728	○	II (ступенчатые)	1,000	1
105031	○	II (ступенчатые)	1,008	0
105032	○	II (ступенчатые)	1,008	1
105033	○	II (ступенчатые)	1,010	1
105034	○	II (ступенчатые)	1,023	1
105035	○	II (ступенчатые)	1,035	1
105036	○	II (ступенчатые)	1,047	1
1132282	○	II (ступенчатые)	1,048	1
105037	○	II (ступенчатые)	1,086	1
105038	○	II (ступенчатые)	1,144	0

Артикул		Тип	D, мм	Класс точности
1142541	○	II (ступенчатые)	1,155	0
105039	○	II (ступенчатые)	1,155	1
105040	○	II (ступенчатые)	1,157	1
105041	○	II (ступенчатые)	1,193	1
105042	○	II (ступенчатые)	1,302	0
105043	○	II (ступенчатые)	1,302	1
105044	○	II (ступенчатые)	1,432	1
105045	○	II (ступенчатые)	1,433	1
1258289	○	II (ступенчатые)	1,441	0
105046	○	II (ступенчатые)	1,441	1
105047	○	II (ступенчатые)	1,443	1
1477486	○	II (ступенчатые)	1,500	1
105048	○	II (ступенчатые)	1,553	0
105049	○	II (ступенчатые)	1,553	1
105050	○	II (ступенчатые)	1,591	0
105051	○	II (ступенчатые)	1,591	1
1134192	○	II (ступенчатые)	1,629	1
105052	○	II (ступенчатые)	1,732	0
105053	○	II (ступенчатые)	1,732	1
1377488	○	II (ступенчатые)	1,750	1
1105784	○	II (ступенчатые)	1,790	1
105054	○	II (ступенчатые)	2,020	0
105055	○	II (ступенчатые)	2,020	1
105056	○	II (ступенчатые)	2,021	1
105057	○	II (ступенчатые)	2,071	0
105058	○	II (ступенчатые)	2,071	1
1184249	○	II (ступенчатые)	2,173	1
105059	○	II (ступенчатые)	2,217	0
105060	○	II (ступенчатые)	2,217	1
1478649	○	II (ступенчатые)	2,250	1
105061	○	II (ступенчатые)	2,309	1
1236027	○	II (ступенчатые)	2,387	1
1415843	○	II (ступенчатые)	2,500	1
1177449	○	II (ступенчатые)	2,588	1
105062	○	II (ступенчатые)	2,595	0
105063	○	II (ступенчатые)	2,595	1
1236028	○	II (ступенчатые)	2,598	0
105064	○	II (ступенчатые)	2,598	1

Артикул		Тип	D, мм	Класс точности
1131046	○	II (ступенчатые)	2,846	1
1139335	○	II (ступенчатые)	2,886	0
105065	○	II (ступенчатые)	2,886	1
1236029	○	II (ступенчатые)	2,887	0
1130098	○	II (ступенчатые)	2,887	1
105066	○	II (ступенчатые)	3,106	0
105067	○	II (ступенчатые)	3,106	1
1177059	○	II (ступенчатые)	3,175	1
105068	○	II (ступенчатые)	3,177	1
1131047	○	II (ступенчатые)	3,182	0
1132281	○	II (ступенчатые)	3,259	1
1236030	○	II (ступенчатые)	3,287	0
1236031	○	II (ступенчатые)	3,287	1
1134193	○	II (ступенчатые)	3,310	1
1378371	○	II (ступенчатые)	3,417	1
117767	○	II (ступенчатые)	3,464	1
1134195	○	II (ступенчатые)	3,468	1
105070	○	II (ступенчатые)	3,500	1

Артикул		Тип	D, мм	Класс точности
117768	○	II (ступенчатые)	3,579	1
1135839	○	II (ступенчатые)	3,580	1
117769	○	II (ступенчатые)	3,623	1
1184294	○	II (ступенчатые)	3,666	0
1105785	○	II (ступенчатые)	3,666	1
1418016	○	II (ступенчатые)	4,000	1
1135840	○	II (ступенчатые)	4,091	1
117770	○	II (ступенчатые)	4,141	0
1639845	○	II (ступенчатые)	4,141	1
1134194	○	II (ступенчатые)	4,211	1
1323648	○	II (ступенчатые)	4,345	1
1135841	○	II (ступенчатые)	4,400	0
105071	○	II (ступенчатые)	4,406	1
1132283	○	II (ступенчатые)	4,733	1
105072	○	III (ролики)	5,500	1
1584858	○	III (ролики)	6,000	1
1284596	○	III (ролики)	6,212	1

Шаблоны радиусные



ТУ 2-034-228-87

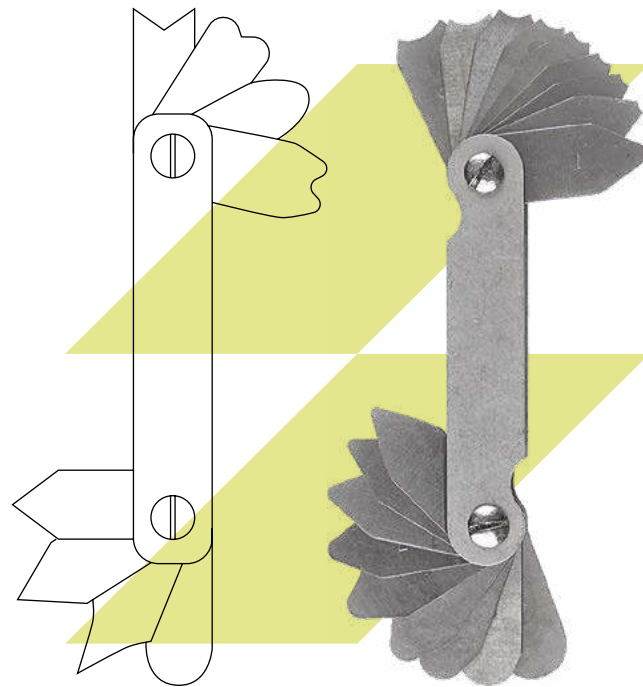

Артикул		Обозначение	Размер	Количество пластин в наборе	Комплектация, радиус, мм
112753		№ 1	R 1–6 мм	18	1; 1,2; 1,6; 2; 2,5; 3; 4; 5; 6
112754		№ 2	R 8–25 мм	12	8; 10; 12; 16; 20; 25
112755		№ 3	R 7–25 мм	24	7; 8; 9; 10; 11; 12; 14; 16; 18; 20; 22; 25

Шаблоны резьбовые



ТУ 2-034-228-87

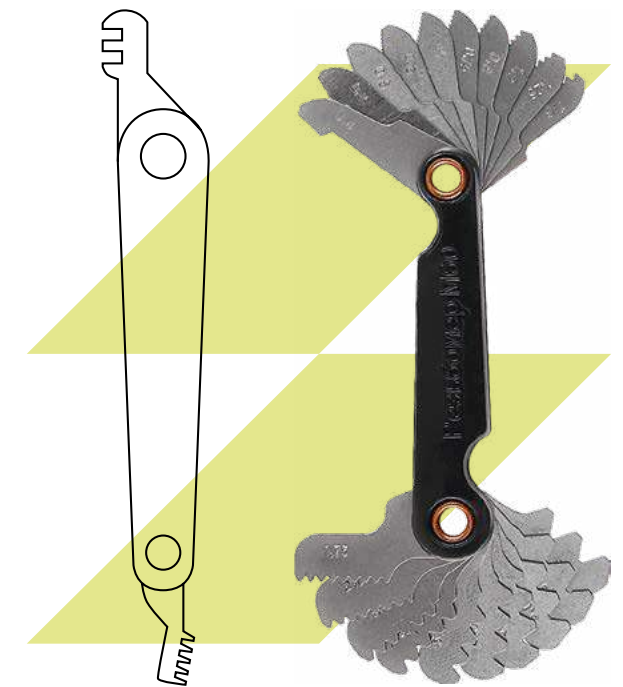

Артикул		Обозначение	Размер	Количество пластин в наборе	Комплектация
112762		Д55	4–28 ниток на дюйм	17	28; 24; 20; 19; 18; 16; 14; 12; 11; 10; 9; 8; 7; 6; 5; 4 ниток на дюйм
112763		М60	0,4–6 шаг резьбы	20	0,4; 0,45; 0,5; 0,6; 0,7; 0,75; 0,8; 1,0; 1,25; 1,5 шаг резьбы
112763		М60	0,4–6 шаг резьбы	20	1,75; 2,0; 2,5; 3,0; 3,5; 4,0; 4,5; 5,0; 5,5; 6,0 шаг резьбы

Наборы щупов



ТУ 2-034-225-87

Артикул	Обозначение	Диапазон измерения, мм	Размер	Класс точности
1242798	№ 1	0,02–0,1	70	–
1289546	№ 1	0,02–0,1	100	–
1418495	№ 2	0,02–0,5	70	–
1289545	№ 2	0,02–0,5	100	–
1242796	№ 3	0,5–1	70	2
112893	№ 3	0,5–1	100	2
1111194	№ 3	0,5–1	100	–
1242797	№ 4	0,1–1	70	–
1596901	№ 4	0,1–1	70	2
115049	№ 4	0,1–1	100	2
1479454	№ 4	0,1–1	100	–

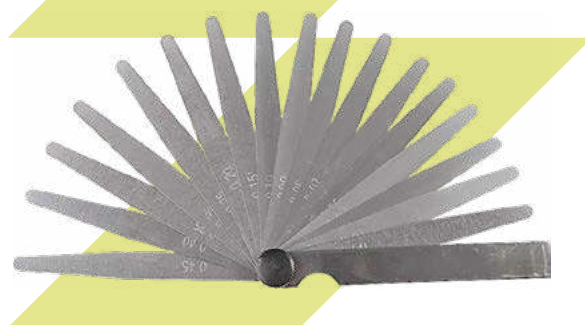
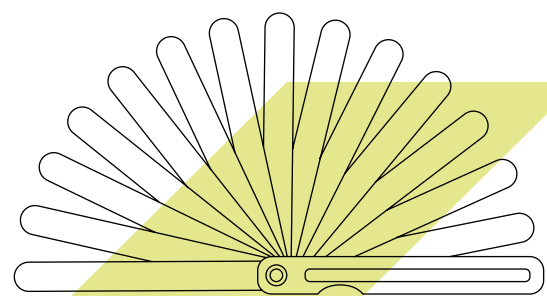

Для заметок

Area with horizontal dashed lines for taking notes.

Измерительный инструмент

Измерительный инструмент

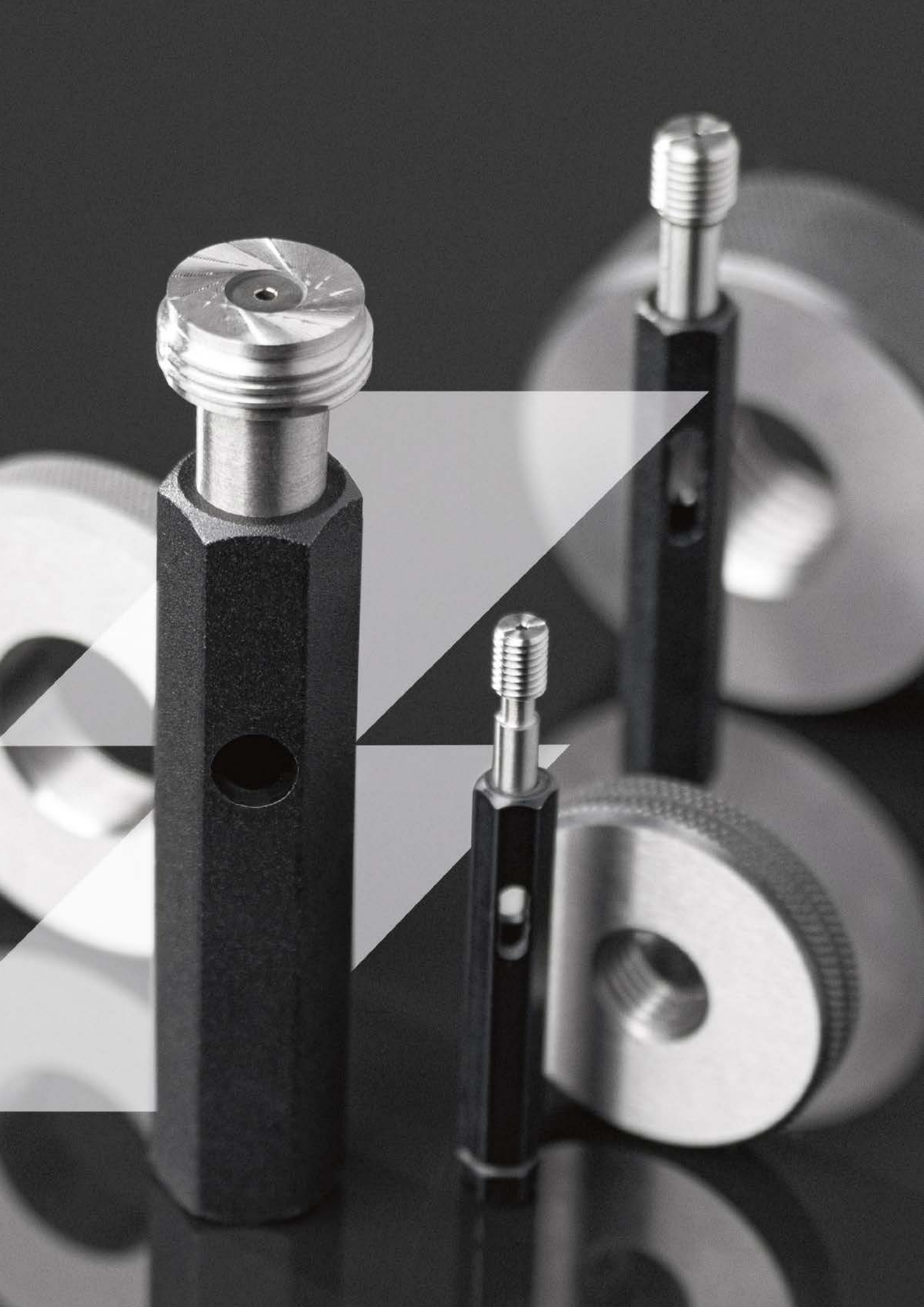

Средства допускового контроля

Калибр-кольца	767
Калибр-пробки	779
Резьбовые	779
Гладкие	786

Калибр-кольца

Калибр-кольца используются для проверки качества резьбы и ее соответствия стандарту, определения диапазонов, в которых может использоваться деталь. Выполнены из прочной легированной стали, устойчивой к износу и истиранию. Удобная форма инструмента облегчает его эксплуатацию. Калибры не проворачиваются в ладонях, что позволяет быстро провести необходимые замеры.



Калибр-пробки

Калибр-пробки применяются для контроля параметров внутренних размеров – отверстий, выемок, пазов. Применяются в серийном, крупносерийном и массовом производстве. При проверке деталь считается годной, если пробка проходит стороной и не проходит непроходным краем через контролируемое отверстие. Усилие, прилагаемое к калибру, должно быть примерно пропорционально его массе. Калибры выполнены из высококачественной легированной стали, благодаря чему обладают высокой прочностью и долговечностью.



Условные обозначения

Основные размеры

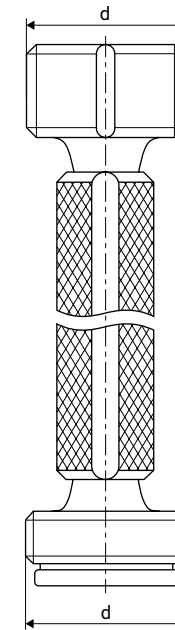

D – диаметр рабочей части
d – диаметр посадки
B – ширина

Тип



Проходные
ПР



Непроходные
НЕ



Проходные-
непроходные
ПР и НЕ

Вид резьбы



Метрическая
М



Средний зуб
Тип 2



Крупный зуб
Тип 3

Наличие инструмента

● На складе в Нижнем Новгороде

○ Под заказ



Обозначение
стандарта



Обозначение
инструментального
материала



Класс точности/
Квалитет

Калибр-кольца

	Резьбовые с полным профилем резьбы	Резьбовые с укороченным профилем резьбы	Резьбовые с полным профилем резьбы	Резьбовые с укороченным профилем резьбы
Стандарт	ГОСТ 17763-72	ГОСТ 17764-72	ГОСТ 17763-72	ГОСТ 17764-72
Тип	Проходные ПР	Непроходные НЕ	Проходные ПР	Непроходные НЕ
Вид резьбы	Метрическая М	Метрическая М	Метрическая М	Метрическая М
Класс точности/кавалитет	6e	6e	6g	6g
Страница	767	769	771	773



	Резьбовые с полным профилем резьбы	Резьбовые с укороченным профилем резьбы
Стандарт	ГОСТ 17763-72	ГОСТ 17764-72
Тип	Проходные ПР	Непроходные НЕ
Вид резьбы	Метрическая М	Метрическая М
Класс точности/кавалитет	6h	6h
Страница	775	777



Калибр-пробки







	Резьбовые со вставками с полным профилем резьбы	Резьбовые со вставками с укороченным профилем резьбы
Стандарт	ГОСТ 17756-72	ГОСТ 17757-72
Тип	Проходные ПР	Непроходные НЕ
Вид резьбы	Метрическая М	Метрическая М
Класс точности/кавалитет	6H	6H
Страница	779	780



	Резьбовые со вставками двусторонние			
Стандарт	ГОСТ 17758-72	ГОСТ 17758-72	ГОСТ 17758-72	ГОСТ 17758-72
Тип	Проходные-непроходные ПР и НЕ	Проходные-непроходные ПР и НЕ	Проходные-непроходные ПР и НЕ	Проходные-непроходные ПР и НЕ
Вид резьбы	Метрическая М	Метрическая М	Метрическая М	Метрическая М
Класс точности/кавалитет	6H	5H6H	6E	7H
Страница	781	783	784	785



Калибр-пробки

	Гладкие					
Стандарт	ГОСТ 21401-75	ГОСТ 21401-75	ГОСТ 21401-75	ГОСТ 21401-75	ГОСТ 21401-75	ГОСТ 21401-75
Тип	Проходные-непроходные ПР и НЕ	Проходные-непроходные ПР и НЕ	Проходные-непроходные ПР и НЕ	Проходные-непроходные ПР и НЕ	Проходные-непроходные ПР и НЕ	Проходные-непроходные ПР и НЕ
Класс точности/кавалитет	6Н	7Н	8Н	9Н	10Н	11Н
Страница	786	787	788	789	790	791
						

	Гладкие	
Стандарт	ГОСТ 21401-75	ГОСТ 21401-75
Тип	Проходные-непроходные ПР и НЕ	Проходные-непроходные ПР и НЕ
Класс точности/кавалитет	12Н	14Н
Страница	792	791
		

Калибр-кольца резьбовые с полным профилем резьбы

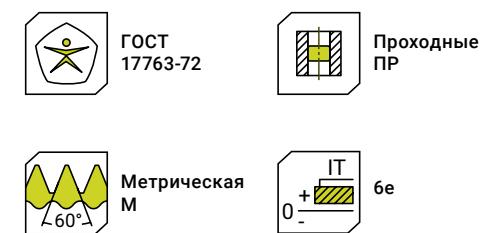

Артикул	Обозначение по ГОСТ	d, мм	Шаг резьбы, мм
1784672	8211-0007	1,4	0,30
1784676	8211-0009	1,6	0,40
1634535	8211-0013	2,0	0,40
1784679	8211-0017	2,5	0,50
1634545	8211-0019	3,0	0,50
1634713	8211-0024	4,0	0,50
1634551	8211-0023	4,0	0,70
1634553	8211-0028	5,0	0,50
1634554	8211-0027	5,0	0,80
1784689	8211-0032	6,0	0,50
1634556	8211-0031	6,0	0,80
1634558	8211-0030	6,0	1,00
1784696	8211-0039	8,0	0,50
1634560	8211-0038	8,0	0,80
1634562	8211-0037	8,0	1,00
1378817	8211-0036	8,0	1,25
1784704	8211-0048	10,0	0,50
1634567	8211-0046	10,0	1,00
1378826	8211-0044	10,0	1,50
1378836	8211-0057	12,0	0,80
1378840	8211-0056	12,0	1,00
1634571	8211-0055	12,0	1,25
1378843	8211-0054	12,0	1,50
1634574	8211-0053	12,0	1,75
1784720	8211-0064	14,0	0,50
1784724	8211-0063	14,0	0,80
1378850	8211-0062	14,0	1,00
1784733	8211-0061	14,0	1,25
1614929	8211-0060	14,0	1,50
1634579	8211-0059	14,0	2,00
1378856	8211-0071	16,0	0,50
1784745	8211-0070	16,0	0,80
1615039	8211-0069	16,0	1,00
1378862	8211-0068	16,0	1,50

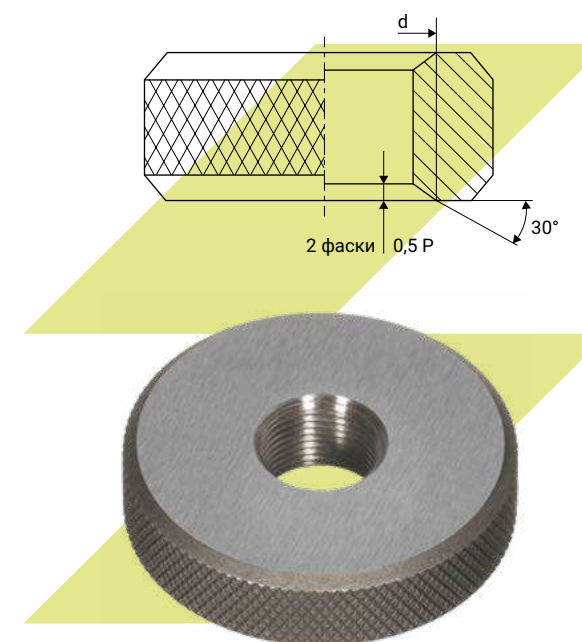

Средства допускового контроля

Средства допускового контроля

Артикул	Обозначение по ГОСТ	d, мм	Шаг резьбы, мм
1634581	8211-0067	16,0	2,00
1634583	8211-0077	18,0	1,00
1634585	8211-0076	18,0	1,50
1784762	8211-0075	18,0	2,00
1634588	8211-0074	18,0	2,50
1784769	8211-0085	20,0	0,50
1784773	8211-0084	20,0	0,80
1378874	8211-0083	20,0	1,00
1378879	8211-0082	20,0	1,50
1784781	8211-0081	20,0	2,00
1634596	8211-0080	20,0	2,50
1784787	8211-0091	22,0	0,50
1784795	8211-0089	22,0	1,00
1784800	8211-0088	22,0	1,50
1784805	8211-0087	22,0	2,00
1634603	8211-0086	22,0	2,50

Артикул	Обозначение по ГОСТ	d, мм	Шаг резьбы, мм
1634607	8211-0095	24,0	1,00
1634609	8211-0094	24,0	1,50
1784815	8211-0093	24,0	2,00
1634612	8211-0092	24,0	3,00
1784821	8211-0105	27,0	0,80
1784825	8211-0104	27,0	1,00
1378903	8211-0103	27,0	1,50
1784832	8211-0102	27,0	2,00
1634618	8211-0101	27,0	3,00
1784843	8211-0114	30,0	0,80
1784847	8211-0113	30,0	1,00
1784851	8211-0112	30,0	1,50
1784855	8211-0111	30,0	2,00
1634625	8211-0109	30,0	3,50
1634627	8211-0121	33,0	1,00
1634628	8211-0120	33,0	1,50

Калибр-кольца резьбовые с укороченным профилем резьбы

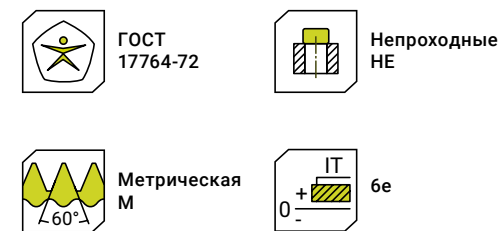

Артикул	Обозначение по ГОСТ	d, мм	Шаг резьбы, мм
1784670	—	1,4	0,30
1784674	—	1,6	0,40
1634533	8211-1013	2,0	0,40
1784678	8211-1017	2,5	0,50
1634543	8211-1019	3,0	0,50
1634547	8211-1024	4,0	0,50
1634550	8211-1023	4,0	0,70
1634552	8211-1028	5,0	0,50
1614918	8211-1027	5,0	0,80
1784688	8211-1032	6,0	0,50
1634555	8211-1031	6,0	0,80
1634557	8211-1030	6,0	1,00
1784694	8211-1039	8,0	0,50
1634559	8211-1038	8,0	0,80
1634561	8211-1037	8,0	1,00
1378815	8211-1036	8,0	1,25
1784702	8211-1048	10,0	0,50
1634566	8211-1046	10,0	1,00
1378824	8211-1044	10,0	1,50
1378834	8211-1057	12,0	0,80
1378838	8211-1056	12,0	1,00
1634569	8211-1055	12,0	1,25
1614927	8211-1054	12,0	1,50
1634573	8211-1053	12,0	1,75
1784718	8211-1064	14,0	0,50
1784722	8211-1063	14,0	0,80
1378849	8211-1062	14,0	1,00
1784730	8211-1061	14,0	1,25
1614930	8211-1060	14,0	1,50
1634578	8211-1059	14,0	2,00
1378854	8211-1071	16,0	0,50
1784742	8211-1070	16,0	0,80
1615038	8211-1069	16,0	1,00
1378860	8211-1068	16,0	1,50

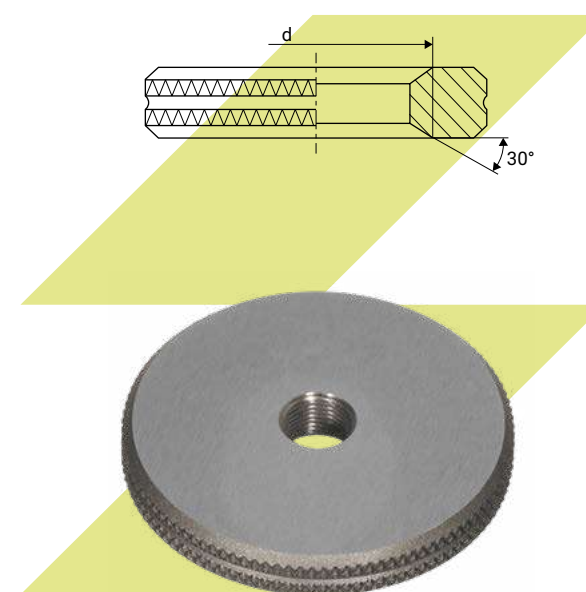

Артикул	Обозначение по ГОСТ	d, мм	Шаг резьбы, мм
1634580	8211-1067	16,0	2,00
1634582	8211-1077	18,0	1,00
1634584	8211-1076	18,0	1,50
1784759	8211-1075	18,0	2,00
1634587	8211-1074	18,0	2,50
1784767	8211-1085	20,0	0,50
1784771	8211-1084	20,0	0,80
1378872	8211-1083	20,0	1,00
1634591	8211-1082	20,0	1,50
1784779	8211-1081	20,0	2,00
1634594	8211-1080	20,0	2,50
1784785	8211-1091	22,0	0,50
1784793	8211-1089	22,0	1,00
1784797	8211-1088	22,0	1,50
1784803	8211-1087	22,0	2,00
1634600	8211-1086	22,0	2,50
1634606	8211-1095	24,0	1,00
1634608	8211-1094	24,0	1,50
1784813	8211-1093	24,0	2,00
1634610	8211-1092	24,0	3,00
1784819	8211-1105	27,0	0,80
1784823	8211-1104	27,0	1,00
1634616	8211-1103	27,0	1,50

Артикул	Обозначение по ГОСТ	d, мм	Шаг резьбы, мм
1784830	8211-1102	27,0	2,00
1634617	8211-1101	27,0	3,00
1784841	8211-1114	30,0	0,80
1784845	8211-1113	30,0	1,00
1784849	8211-1112	30,0	1,50
1784853	8211-1111	30,0	2,00
1634624	8211-1109	30,0	3,50
1634626	8211-1121	33,0	1,00
1378922	8211-1120	33,0	1,50
1378925	8211-1119	33,0	2,00
1634621	8211-1111	30,0	2,00
1378908	8211-1109	30,0	3,50
1378918	8211-1122	33,0	0,80
1378920	8211-1121	33,0	1,00
1378923	8211-1120	33,0	1,50
1784867	8211-1119	33,0	2,00
1378916	8211-1117	33,0	3,50
1634629	8211-1128	36,0	1,00
1634631	8211-1126	36,0	2,00
1378927	8211-1124	36,0	4,00
1614937	8211-1141	42,0	2,00
1378930	8211-1153	48,0	2,00
1378940	8211-1230	80,0	2,00

Калибр-кольца резьбовые с полным профилем резьбы

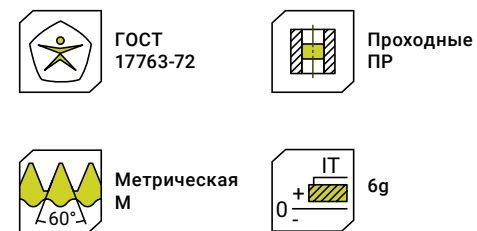

Артикул	Обозначение по ГОСТ	d, мм	Шаг резьбы, мм
1634526	8211-0001	1,0	0,30
1634528	8211-0005	1,2	0,30
1634530	8211-0007	1,4	0,30
1634532	8211-0009	1,6	0,40
1614917	8211-0013	2,0	0,40
1634538	8211-0018	2,5	0,40
1378799	8211-0017	2,5	0,50
1378801	8211-0019	3,0	0,50
1378804	8211-0024	4,0	0,50
1378803	8211-0023	4,0	0,70
1378808	8211-0028	5,0	0,50
1378806	8211-0027	5,0	0,80
1378813	8211-0032	6,0	0,50
1614920	8211-0031	6,0	0,80
1378810	8211-0030	6,0	1,00
1378821	8211-0039	8,0	0,50
1614922	8211-0038	8,0	0,80
1378823	8211-0037	8,0	1,00
1378818	8211-0036	8,0	1,25
1378829	8211-0048	10,0	0,50
1614924	8211-0048	10,0	0,80
1378831	8211-0046	10,0	1,00
1378827	8211-0044	10,0	1,50
1614926	8211-0058	12,0	0,50
1378837	8211-0057	12,0	0,80
1378841	8211-0056	12,0	1,00
1634572	8211-0055	12,0	1,25
1378844	8211-0054	12,0	1,50
1378833	8211-0053	12,0	1,75
1784725	8211-0063	14,0	0,80
1378851	8211-0062	14,0	1,00
1784734	8211-0061	14,0	1,25
1634577	8211-0060	14,0	1,50
1378846	8211-0059	14,0	2,00

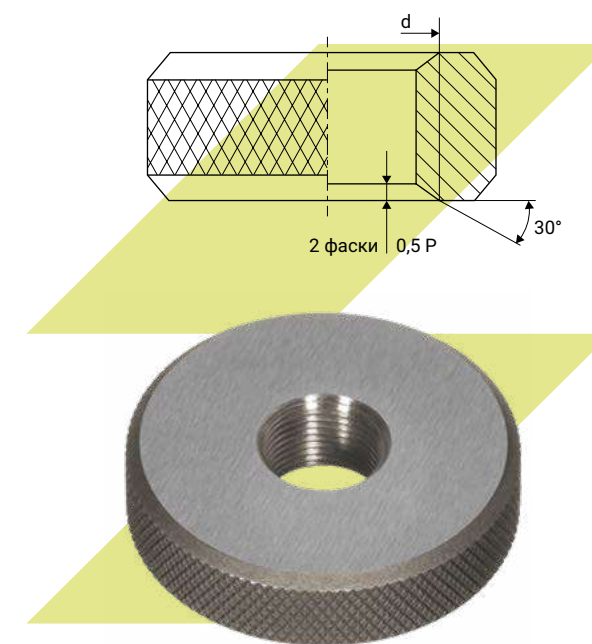

Средства допускового контроля

Средства допускового контроля

Артикул	Обозначение по ГОСТ	d, мм	Шаг резьбы, мм
1378857	8211-0071	16,0	0,50
1614931	8211-0070	16,0	0,80
1378859	8211-0069	16,0	1,00
1378853	8211-0067	16,0	2,00
1614933	8211-0073	17,0	1,00
1784754	8211-0078	18,0	0,80
1378867	8211-0077	18,0	1,00
1634586	8211-0076	18,0	1,50
1784763	8211-0075	18,0	2,00
1378865	8211-0074	18,0	2,50
1378871	8211-0085	20,0	0,50
1634590	8211-0084	20,0	0,80
1378875	8211-0083	20,0	1,00
1378880	8211-0082	20,0	1,50
1378883	8211-0081	20,0	2,00
1378885	8211-0091	22,0	0,50
1379242	8211-0090	22,0	0,80
1378886	8211-0089	22,0	1,00
1784801	8211-0088	22,0	1,50
1378889	8211-0087	22,0	2,00
1378893	8211-0095	24,0	1,00
1378895	8211-0094	24,0	1,50
1378897	8211-0093	24,0	2,00
1378891	8211-0092	24,0	3,00

Артикул	Обозначение по ГОСТ	d, мм	Шаг резьбы, мм
1378899	8211-0099	25,0	1,00
1634615	8211-0105	27,0	0,80
1784826	8211-0104	27,0	1,00
1378904	8211-0103	27,0	1,50
1378906	8211-0102	27,0	2,00
1378901	8211-0101	27,0	3,00
1378907	8211-0108	28,0	1,00
1379245	8211-0114	30,0	0,80
1378911	8211-0113	30,0	1,00
1378915	8211-0111	30,0	2,00
1378909	8211-0109	30,0	3,50
1378919	8211-0122	33,0	0,80
1378921	8211-0121	33,0	1,00
1378924	8211-0120	33,0	1,50
1784869	8211-0119	33,0	2,00
1378917	8211-0117	33,0	3,50
1634632	8211-0126	36,0	2,00
1378928	8211-0124	36,0	4,00
1378929	8211-0143	42,0	1,00
1614936	8211-0141	42,0	2,00
1378931	8211-0153	48,0	2,00
1378934	8211-0173	56,0	1,50
1614938	8211-0230	80,0	2,00

Калибр-кольца резьбовые с укороченным профилем резьбы



Артикул	Обозначение по ГОСТ	d, мм	Шаг резьбы, мм
1634525	—	1,0	0,30
1634527	—	1,2	0,30
1634529	—	1,4	0,30
1634531	—	1,6	0,40
1614916	8211-1013	2,0	0,40
1634537	—	2,5	0,40
1378798	8211-1017	2,5	0,50
1378800	8211-1019	3,0	0,50
1634548	8211-1024	4,0	0,50
1378802	8211-1023	4,0	0,70
1378807	8211-1028	5,0	0,50
1378805	8211-1027	5,0	0,80
1378811	8211-1032	6,0	0,50
1614919	8211-1031	6,0	0,80
1378809	8211-1030	6,0	1,00
1378819	8211-1039	8,0	0,50
1614921	8211-1038	8,0	0,80
1378822	8211-1037	8,0	1,00
1378816	8211-1036	8,0	1,25
1378828	8211-1048	10,0	0,50
1614923	8211-1047	10,0	0,80
1378830	8211-1046	10,0	1,00
1378825	8211-1044	10,0	1,50
1614925	8211-1058	12,0	0,50
1378835	8211-1057	12,0	0,80
1378839	8211-1056	12,0	1,00
1634570	8211-1055	12,0	1,25
1378842	8211-1054	12,0	1,50
1378832	8211-1053	12,0	1,75
1378847	8211-1064	14,0	0,50
1614928	8211-1063	14,0	0,80
1784727	8211-1062	14,0	1,00
1784731	8211-1061	14,0	1,25
1634576	8211-1060	14,0	1,50

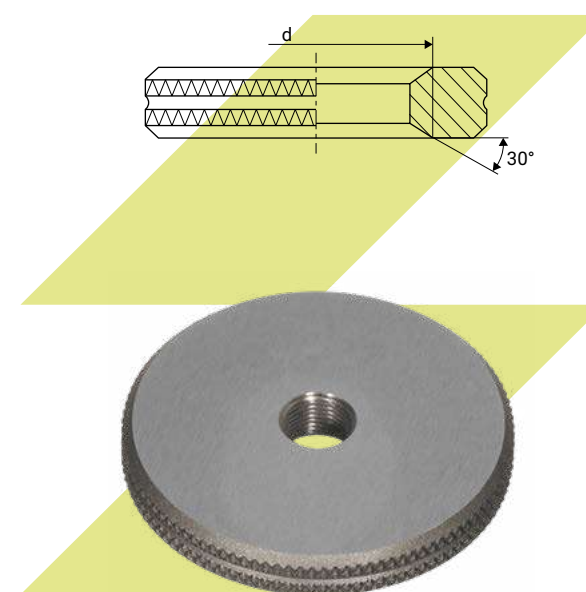

Средства допускового контроля

Средства допускового контроля

Артикул	Обозначение по ГОСТ	d, мм	Шаг резьбы, мм
1378845	8211-1059	14,0	2,00
1378855	8211-1071	16,0	0,50
1784743	8211-1070	16,0	0,80
1378858	8211-1069	16,0	1,00
1378861	8211-1068	16,0	1,50
1378852	8211-1067	16,0	2,00
1614932	8211-1073	17,0	1,00
1784753	8211-1078	18,0	0,80
1378866	8211-1077	18,0	1,00
1614934	8211-1076	18,0	1,50
1784760	8211-1075	18,0	2,00
1378864	8211-1074	18,0	2,50
1378870	8211-1085	20,0	0,50
1634589	8211-1084	20,0	0,80
1378873	8211-1083	20,0	1,00
1378877	8211-1082	20,0	1,50
1378882	8211-1081	20,0	2,00
1378868	8211-1080	20,0	2,50
1378884	8211-1091	22,0	0,50

Артикул	Обозначение по ГОСТ	d, мм	Шаг резьбы, мм
1614935	8211-1090	22,0	0,80
1378887	8211-1089	22,0	1,00
1784798	8211-1088	22,0	1,50
1378888	8211-1087	22,0	2,00
1634601	8211-1086	22,0	2,50
1378892	8211-1095	24,0	1,00
1378894	8211-1094	24,0	1,50
1378896	8211-1093	24,0	2,00
1378890	8211-1092	24,0	3,00
1378898	8211-1099	25,0	1,00
1634614	8211-1105	27,0	0,80
1379243	8211-1104	27,0	1,00
1378902	8211-1103	27,0	1,50
1378905	8211-1102	27,0	2,00
1378900	8211-1101	27,0	3,00
1784837	8211-1108	28,0	1,00
1379244	8211-1114	30,0	0,80
1378910	8211-1113	30,0	1,00

Калибр-кольца резьбовые с полным профилем резьбы

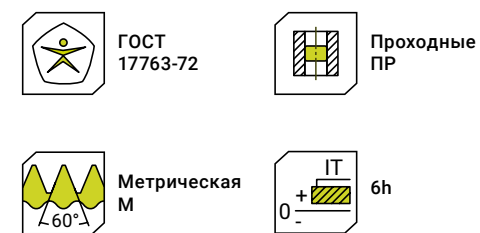

Артикул	Обозначение по ГОСТ	d, мм	Шаг резьбы, мм
1784673	8211-0001	1,0	0,30
1784677	8211-0005	1,2	0,30
1634536	8211-0007	1,4	0,30
1634542	8211-0009	1,6	0,40
1634546	8211-0013	2,0	0,40
1784681	8211-0018	2,5	0,40
1784683	8211-0017	2,5	0,50
1784685	8211-0019	3,0	0,50
1784687	8211-0024	4,0	0,50
1378814	8211-0023	4,0	0,70
1784691	8211-0028	5,0	0,50
1784693	8211-0027	5,0	0,80
1784697	8211-0032	6,0	0,50
1784699	8211-0031	6,0	0,80
1784701	8211-0030	6,0	1,00
1784705	8211-0039	8,0	0,50
1784707	8211-0038	8,0	0,80
1784709	8211-0037	8,0	1,00
1784711	8211-0036	8,0	1,25
1784713	8211-0048	10,0	0,50
1784715	8211-0048	10,0	0,80
1784717	8211-0046	10,0	1,00
1784721	8211-0044	10,0	1,50
1784726	8211-0058	12,0	0,50
1784729	8211-0057	12,0	0,80
1784735	8211-0056	12,0	1,00
1784737	8211-0055	12,0	1,25
1784741	8211-0053	12,0	1,75
1784746	8211-0064	14,0	0,50
1784748	8211-0063	14,0	0,80
1784750	8211-0062	14,0	1,00
1784752	8211-0061	14,0	1,25
1784756	8211-0060	14,0	1,50
1784758	8211-0059	14,0	2,00

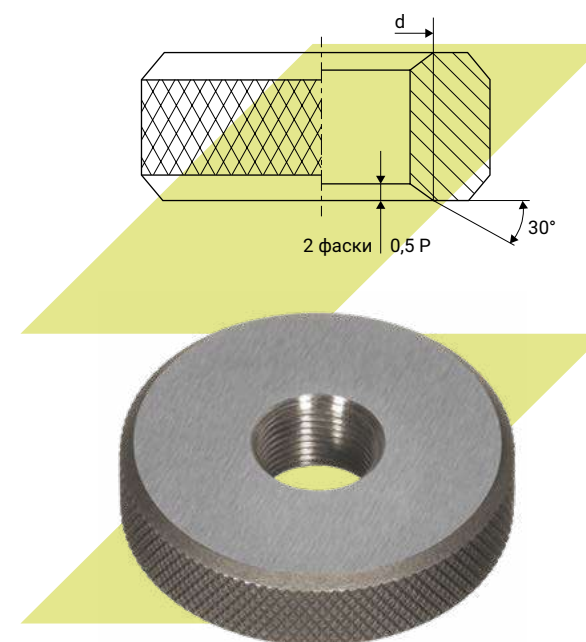

Артикул	Обозначение по ГОСТ	d, мм	Шаг резьбы, мм
1784764	8211-0071	16,0	0,50
1784770	8211-0070	16,0	0,80
1784774	8211-0069	16,0	1,00
1784776	8211-0068	16,0	1,50
1784778	8211-0067	16,0	2,00
1784782	8211-0073	17,0	1,00
1784784	8211-0078	18,0	0,80
1784796	8211-0075	18,0	2,00
1784802	8211-0074	18,0	2,50
1784806	8211-0085	20,0	0,50
1784808	8211-0084	20,0	0,80
1784810	8211-0083	20,0	1,00
1784812	8211-0082	20,0	1,50
1784816	8211-0081	20,0	2,00

Артикул	Обозначение по ГОСТ	d, мм	Шаг резьбы, мм
1784818	8211-0080	20,0	2,50
1784822	8211-0091	22,0	0,50
1784827	8211-0090	22,0	0,80
1784829	8211-0089	22,0	1,00
1784833	8211-0088	22,0	1,50
1784835	8211-0087	22,0	2,00
1784840	8211-0086	22,0	2,50
1784844	8211-0095	24,0	1,00
1784848	8211-0094	24,0	1,50
1784852	8211-0093	24,0	2,00
1784856	8211-0092	24,0	3,00
1784858	8211-0099	25,0	1,00
1784862	8211-0105	27,0	0,80
1784864	8211-0104	27,0	1,00

Калибр-кольца резьбовые с укороченным профилем резьбы



Артикул	Обозначение по ГОСТ	d, мм	Шаг резьбы, мм
1784671	—	1,4	0,30
1784675	—	1,6	0,40
1634534	8211-1013	2,0	0,40
1634540	8211-1017	2,5	0,50
1634544	8211-1019	3,0	0,50
1784680	8211-1024	4,0	0,50
1784682	8211-1023	4,0	0,70
1784684	8211-1028	5,0	0,50
1784686	8211-1027	5,0	0,80
1378812	8211-1032	6,0	0,50
1784690	8211-1031	6,0	0,80
1784692	8211-1030	6,0	1,00
1784695	8211-1039	8,0	0,50
1784698	8211-1037	8,0	1,00
1784700	8211-1036	8,0	1,25
1784703	8211-1048	10,0	0,50
1784706	8211-1047	10,0	0,80
1784708	8211-1046	10,0	1,00
1784710	8211-1044	10,0	1,50
1784712	8211-1056	12,0	1,00
1784714	8211-1054	12,0	1,50
1784716	8211-1053	12,0	1,75
1784719	8211-1064	14,0	0,50
1784723	8211-1063	14,0	0,80
1784728	8211-1062	14,0	1,00
1784732	8211-1061	14,0	1,25
1784736	8211-1060	14,0	1,50
1784738	8211-1059	14,0	2,00
1784740	8211-1071	16,0	0,50
1784744	8211-1070	16,0	0,80
1784747	8211-1069	16,0	1,00
1784749	8211-1068	16,0	1,50
1784751	8211-1067	16,0	2,00
1784755	8211-1077	18,0	1,00

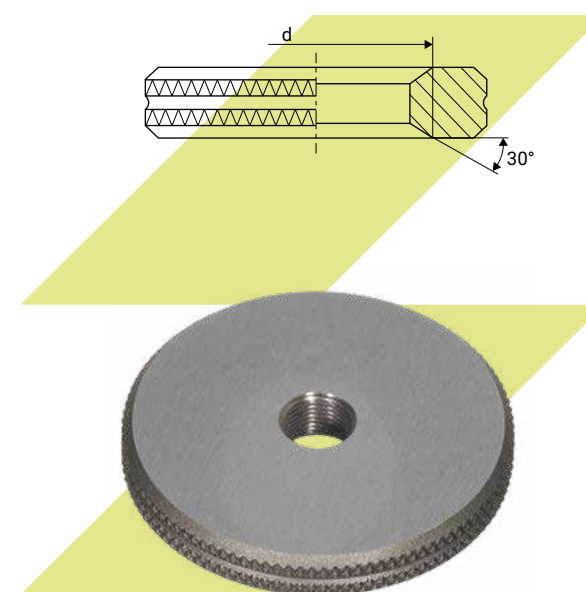

Артикул	Обозначение по ГОСТ	d, мм	Шаг резьбы, мм
1784757	8211-1076	18,0	1,50
1784761	8211-1075	18,0	2,00
1784765	8211-1074	18,0	2,50
1784766	8211-0074	18,0	2,50
1784768	8211-1085	20,0	0,50
1784772	8211-1084	20,0	0,80
1784775	8211-1083	20,0	1,00
1784777	8211-1082	20,0	1,50
1784780	8211-1081	20,0	2,00
1784783	8211-1080	20,0	2,50
1784790	8211-1090	22,0	0,80
1784794	8211-1089	22,0	1,00
1784799	8211-1088	22,0	1,50
1784804	8211-1087	22,0	2,00
1784807	8211-1086	22,0	2,50
1784809	8211-1095	24,0	1,00
1784811	8211-1094	24,0	1,50

Артикул	Обозначение по ГОСТ	d, мм	Шаг резьбы, мм
1784814	8211-1093	24,0	2,00
1784817	8211-1092	24,0	3,00
1784820	8211-1105	27,0	0,80
1784824	8211-1104	27,0	1,00
1784828	8211-1103	27,0	1,50
1784831	8211-1102	27,0	2,00
1784834	8211-1101	27,0	3,00
1784838	8211-1108	28,0	1,00
1784842	8211-1114	30,0	0,80
1784846	8211-1113	30,0	1,00
1784850	8211-1112	30,0	1,50
1784854	8211-1111	30,0	2,00
1784857	8211-1109	30,0	3,50
1784860	8211-1122	33,0	0,80
1784863	8211-1121	33,0	1,00
1784865	8211-1120	33,0	1,50

Калибр-пробки резьбовые со вставками с полным профилем резьбы

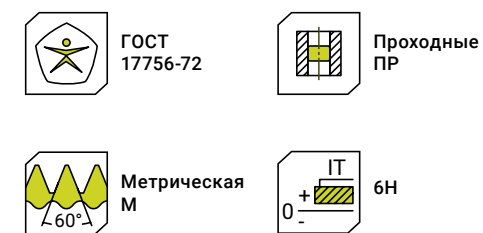

Артикул	Обозначение по ГОСТ	d, мм	Шаг резьбы, мм
1378974	8221-0027	5,0	0,80
1378979	8221-0030	6,0	1,00
1378985	8221-0036	8,0	1,25
1634653	8221-0045	10,0	1,25
1378991	8221-0044	10,0	1,50
1378998	8221-0053	12,0	1,75
1634659	8221-0070	16,0	0,75
1634662	8221-0068	16,0	1,50
1379045	8221-0082	20,0	1,50
1379040	8221-0080	20,0	2,50
1379051	8221-0090	22,0	0,75
1634683	8221-0088	22,0	1,50
1634684	8221-0087	22,0	2,00
1379048	8221-0086	22,0	2,50
1634686	8221-0094	24,0	1,50
1379059	8221-0092	24,0	3,00
1379066	8221-0103	27,0	1,50
1634692	8221-0101	27,0	3,00
1634697	8221-0109	30,0	3,50
1615015	—	100,0	2,00

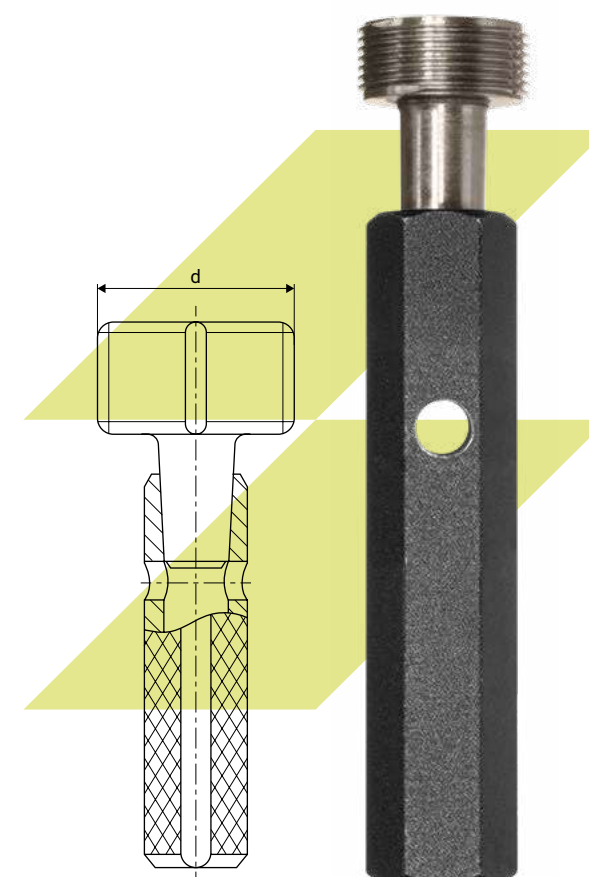

Калибр-пробки резьбовые со вставками с укороченным профилем резьбы



Артикул	Обозначение по ГОСТ	d, мм	Шаг резьбы, мм
1378973	8221-1027	5,0	0,80
1378984	8221-1036	8,0	1,25
1634650	8221-1047	10,0	0,75
1634652	8221-1045	10,0	1,25
1378990	8221-1044	10,0	1,50
1378997	8221-1053	12,0	1,75
1634658	8221-1070	16,0	0,75
1784904	8221-1069	16,0	1,00
1634661	8221-1068	16,0	1,50
1379044	8221-1082	20,0	1,50
1379039	8221-1080	20,0	2,50
1634682	8221-1088	22,0	1,50
1379047	8221-1086	22,0	2,50
1379058	8221-1092	24,0	3,00
1379065	8221-1103	27,0	1,50
1634691	8221-1101	27,0	3,00
1634693	8221-1112	30,0	1,50
1634696	8221-1109	30,0	3,50
1634698	8221-1109	33,0	3,50
1615014	-	100,0	2,00

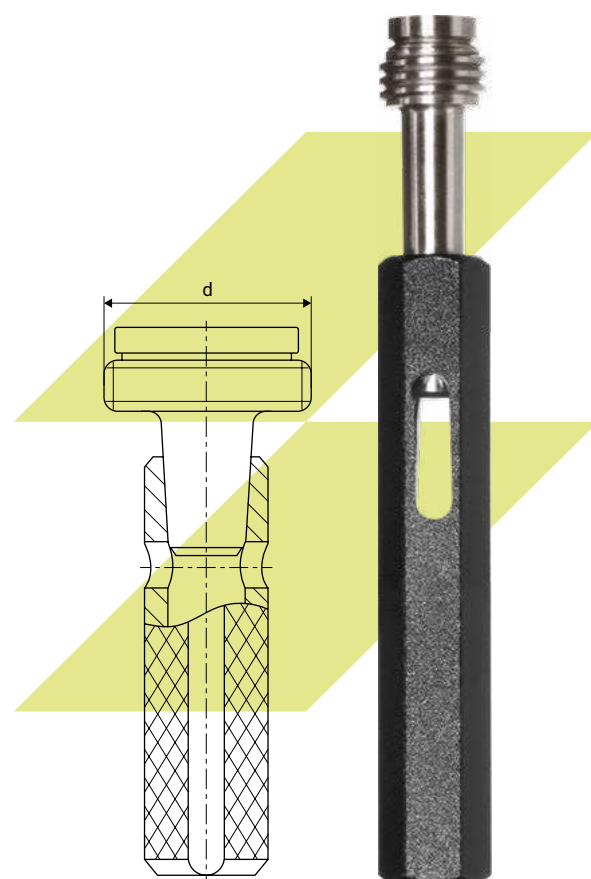

Калибр-пробки резьбовые со вставками двусторонние



Артикул	Обозначение по ГОСТ	d, мм	Шаг резьбы, мм
1634634	-	1,0	0,25
1634637	-	1,4	0,30
1634640	-	1,6	0,35
1614939	8221-3013	2,0	0,40
1614943	8221-3017	2,5	0,45
1614947	8221-3019	3,0	0,50
1378968	8221-3021	3,5	0,60
1634644	8221-3024	4,0	0,50
1378969	8221-3023	4,0	0,70
1634646	8221-3028	5,0	0,50
1378972	8221-3027	5,0	0,80
1614956	8221-3031	6,0	0,75
1378977	8221-3030	6,0	1,00
1378982	8221-3033	7,0	1,00
1378986	8221-3039	8,0	0,50
1378987	8221-3038	8,0	0,75
1378988	8221-3037	8,0	1,00
1378983	8221-3036	8,0	1,25
1378992	8221-3048	10,0	0,50
1378993	8221-3047	10,0	0,75
1614963	8221-3046	10,0	1,00
1614965	8221-3045	10,0	1,25
1378989	8221-3044	10,0	1,50
1614970	8221-3058	12,0	0,50
1634655	8221-3056	12,0	1,00
1379007	8221-3055	12,0	1,25
1379010	8221-3054	12,0	1,50
1378996	8221-3053	12,0	1,75
1379013	8221-3064	14,0	0,50
1379014	8221-3063	14,0	0,75
1379015	8221-3062	14,0	1,00
1379016	8221-3061	14,0	1,25
1379017	8221-3060	14,0	1,50
1614979	8221-3059	14,0	2,00

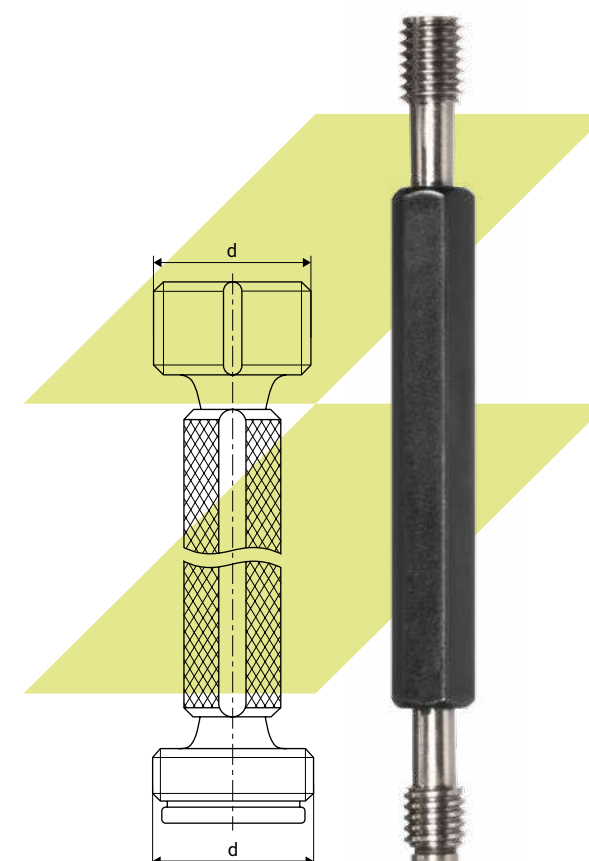

Артикул	Обозначение по ГОСТ	d, мм	Шаг резьбы, мм
1379023	8221-3071	16,0	0,50
1379024	8221-3070	16,0	0,75
1379027	8221-3068	16,0	1,50
1379018	8221-3067	16,0	2,00
1379030	8221-3079	18,0	0,50
1379031	8221-3078	18,0	0,75
1614986	8221-3076	18,0	1,50
1379038	8221-3075	18,0	2,00
1634670	8221-3074	18,0	2,50
1379041	8221-3085	20,0	0,50
1614988	8221-3084	20,0	0,75
1614989	8221-3083	20,0	1,00
1634673	8221-3082	20,0	1,50
1379046	8221-3081	20,0	2,00
1634677	8221-3080	20,0	2,50
1614991	8221-3090	22,0	0,75
1379052	8221-3089	22,0	1,00
1379055	8221-3088	22,0	1,50
1379056	8221-3087	22,0	2,00
1614997	8221-3094	24,0	1,50
1379057	8221-3092	24,0	3,00
1379063	8221-3105	27,0	0,75
1379064	8221-3104	27,0	1,00

Артикул	Обозначение по ГОСТ	d, мм	Шаг резьбы, мм
1615003	8221-3103	27,0	1,50
1379067	8221-3102	27,0	2,00
1634689	8221-3101	27,0	3,00
1379070	8221-3113	30,0	1,00
1379071	8221-3112	30,0	1,50
1379072	8221-3111	30,0	2,00
1634695	8221-3109	30,0	3,50
1784907	8221-3115	32,0	2,00
1379073	8221-3117	33,0	3,50
1379075	8221-3128	36,0	1,00
1379076	8221-3127	36,0	1,50
1379077	8221-3126	36,0	2,00
1379078	8221-3125	36,0	3,00
1634699	8221-3124	36,0	4,00
1379079	8221-3134	39,0	1,00
1634700	8221-3133	39,0	1,50
1379080	8221-3132	39,0	2,00
1634701	8221-3131	39,0	3,00
1379074	8221-3130	39,0	4,00
1379083	8221-3148	42,0	1,50
1379084	8221-3147	42,0	2,00
1379085	8221-3146	42,0	3,00

Калибр-пробки резьбовые со вставками двусторонние



Артикул	Обозначение по ГОСТ	d, мм	Шаг резьбы, мм
1634636	—	1,4	0,30
1634639	—	1,6	0,35
1634642	8221-3013	2,0	0,40
1614941	8221-3017	2,5	0,45
1614945	8221-3019	3,0	0,50
1784896	8221-3024	4,0	0,50
1614949	8221-3023	4,0	0,70
1634645	8221-3028	5,0	0,50
1614952	8221-3027	5,0	0,80
1784900	8221-3028	6,0	0,50
1614957	8221-3030	6,0	1,00
1784901	8221-3039	8,0	0,50
1634648	8221-3037	8,0	1,00
1614961	8221-3036	8,0	1,25
1614966	8221-3044	10,0	1,50
1634654	8221-3056	12,0	1,00
1634656	8221-3063	14,0	0,75
1614974	8221-3060	14,0	1,50
1614977	8221-3059	14,0	2,00
1614981	8221-3068	16,0	1,50
1634663	8221-3067	16,0	2,00
1634666	8221-3077	18,0	1,00
1614983	8221-3076	18,0	1,50
1634669	8221-3074	18,0	2,50
1634679	8221-3089	22,0	1,00
1634681	8221-3088	22,0	1,50
1614992	8221-3088	22,0	1,50
1634685	8221-3094	24,0	1,50
1614999	8221-3093	24,0	2,00
1615002	8221-3103	27,0	1,50
1615006	8221-3102	27,0	2,00
1615010	8221-3120	33,0	1,50

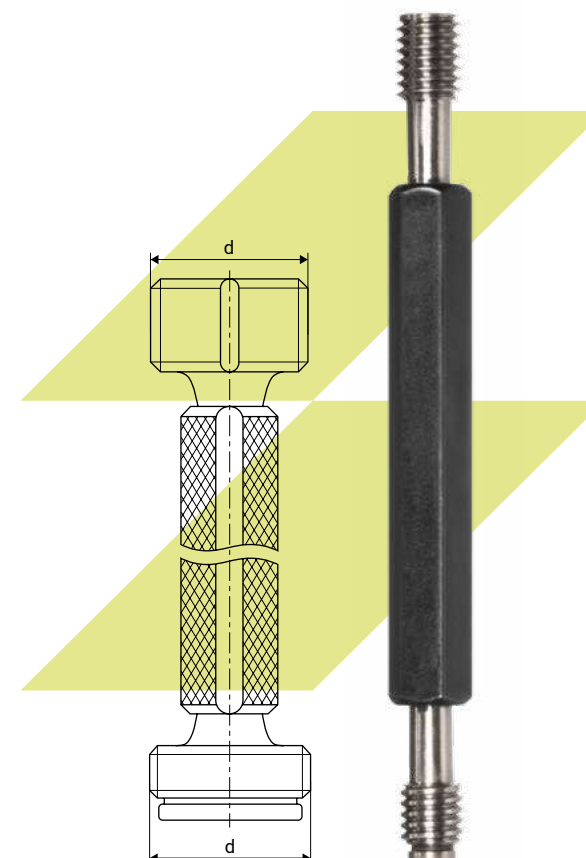

Калибр-пробки резьбовые со вставками двусторонние



Артикул	Обозначение по ГОСТ	d, мм	Шаг резьбы, мм
1634633	8221-3010	1,0	0,25
1784887	8221-3011	1,4	0,30
1784889	8221-3012	1,6	0,35
1784891	8221-3013	2,0	0,40
1784892	8221-3017	2,5	0,45
1784894	8221-3019	3,0	0,50
1784898	8221-3023	4,0	0,70
1784899	8221-3027	5,0	0,80
1614959	8221-3030	6,0	1,00
1784902	8221-3036	8,0	1,25
1784903	8221-3044	10,0	1,50
1614985	8221-3076	18,0	1,50

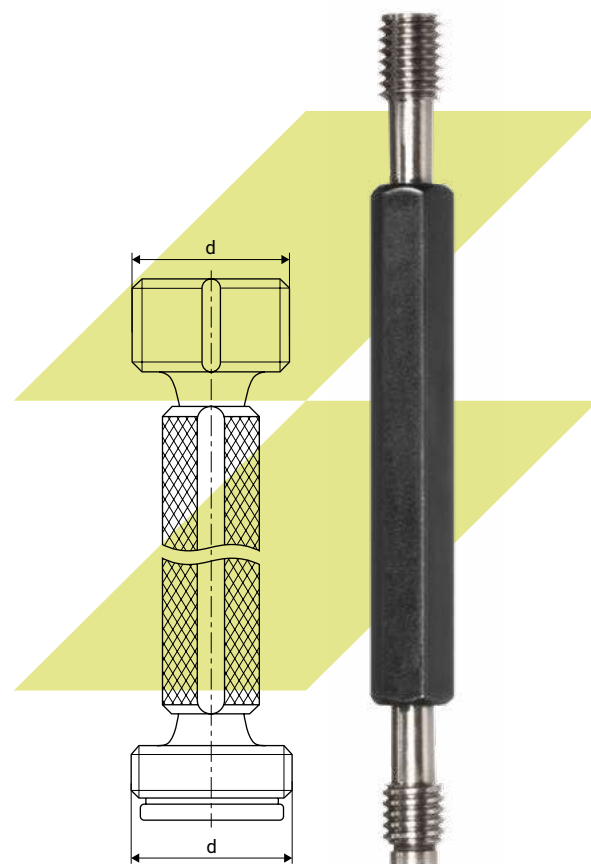

Калибр-пробки резьбовые со вставками двусторонние



Артикул	Обозначение по ГОСТ	d, мм	Шаг резьбы, мм
1634635	—	1,0	0,25
1634638	—	1,4	0,30
1634641	—	1,6	0,35
1634643	8221-3013	2,0	0,40
1614944	8221-3017	2,5	0,45
1614948	8221-3019	3,0	0,50
1784897	8221-3024	4,0	0,50
1614951	8221-3023	4,0	0,70
1634647	8221-3028	5,0	0,50
1614955	8221-3027	5,0	0,80
1614960	8221-3030	6,0	1,00
1634649	8221-3036	8,0	1,25
1614964	8221-3046	10,0	1,00
1614968	8221-3044	10,0	1,50
1614972	8221-3053	12,0	1,75
1634657	8221-3063	14,0	0,75
1614976	8221-3060	14,0	1,50
1614980	8221-3059	14,0	2,00
1634660	8221-3068	16,0	1,50
1634664	8221-3067	16,0	2,00
1634665	8221-3078	18,0	0,75
1634667	8221-3077	18,0	1,00
1614987	8221-3076	18,0	1,50
1634671	8221-3074	18,0	2,50
1634674	8221-3082	20,0	1,50
1634678	8221-3080	20,0	2,50
1634680	8221-3089	22,0	1,00
1614994	8221-3088	22,0	1,50
1615001	8221-3093	24,0	2,00
1784905	8221-3092	24,0	3,00
1615004	8221-3103	27,0	1,50
1634690	8221-3101	27,0	3,00
1784906	8221-3113	30,0	1,00
1784908	8221-3127	36,0	1,50

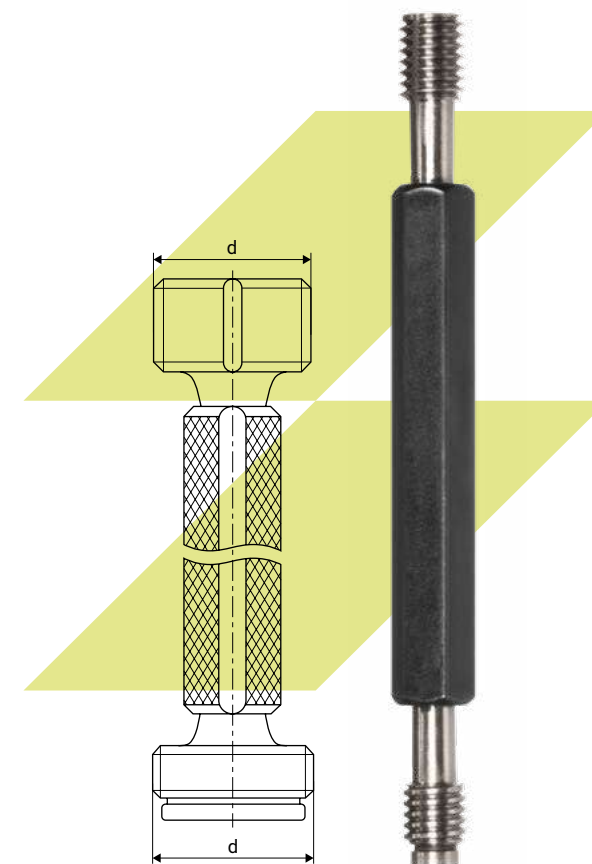

Калибр-пробки гладкие

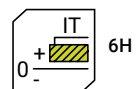

Артикул		d, мм
1582722	●	1,38
1533079	●	2,00
1582746	●	2,30
1533111	●	3,00
1784885	●	4,30

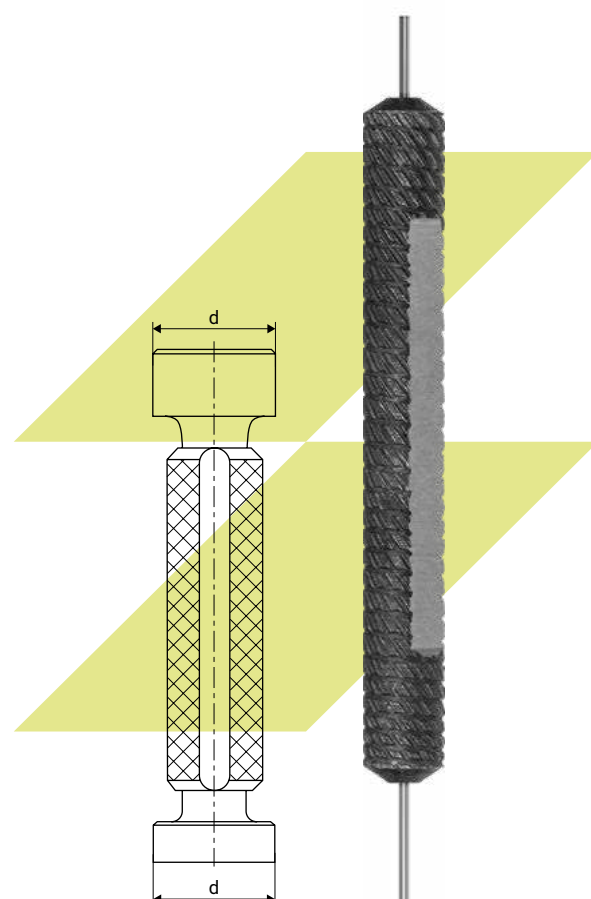

Калибр-пробки гладкие

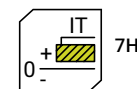

Артикул		d, мм
1784872	●	0,80
1582709	●	1,00
1582717	●	1,30
1736976	●	1,50
1582735	●	1,60
1533077	●	1,90
1533080	●	2,00
1784877	●	2,20
1533088	●	2,30
1533093	●	2,40
1763507	●	2,50
1533104	●	2,70
1736980	●	2,90
1533110	●	2,95
1736982	●	3,00
1784880	●	3,40
1736993	●	4,00
1737006	●	5,00
1737020	●	6,00

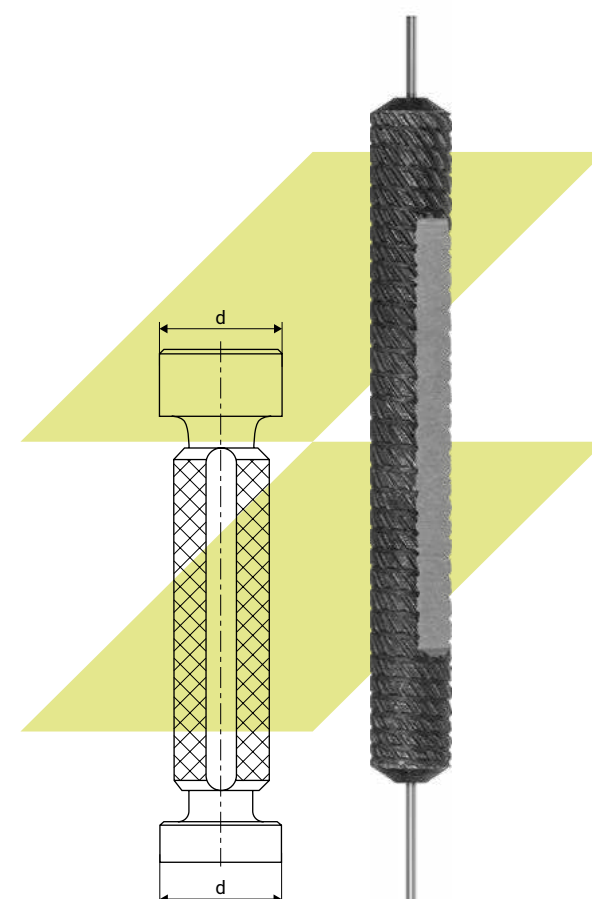

Калибр-пробки гладкие

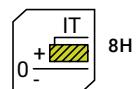

Артикул		d, мм
1582686	●	0,44
1582687	●	0,49
1582691	●	0,54
1582692	●	0,56
1582693	●	0,58
1582694	●	0,64
1784873	●	0,80
1582710	●	1,00
1582723	●	1,40
1582727	●	1,45
1784875	●	1,50
1582734	●	1,55
1582736	●	1,60
1533081	●	2,00
1533085	●	2,10
1533101	●	2,60
1729425	●	2,90
1533112	●	3,00
1737007	●	5,00

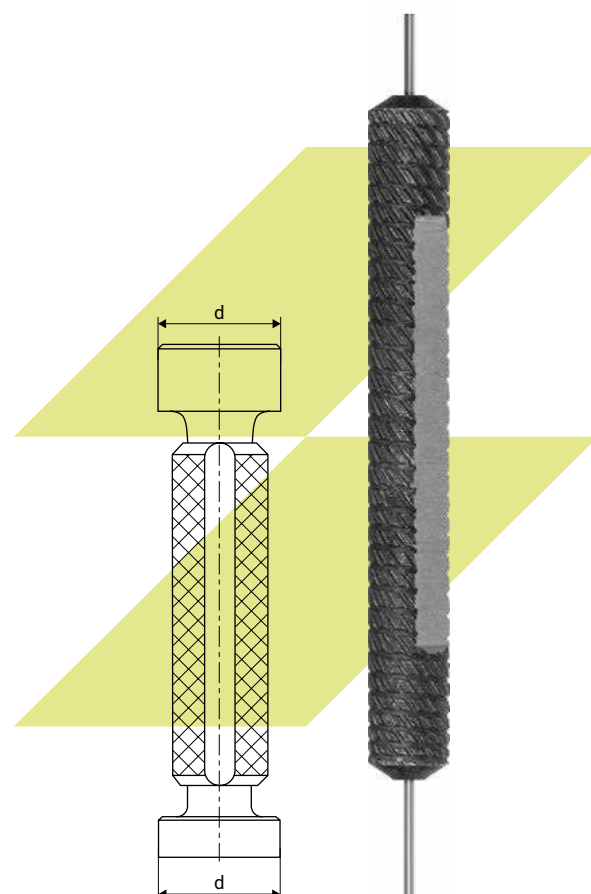

Калибр-пробки гладкие

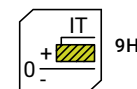

Артикул		d, мм
1582688	●	0,50
1582695	●	0,60
1582699	●	0,70
1582711	●	1,00
1736974	●	1,20
1582718	●	1,30
1582724	●	1,40
1582728	●	1,45
1582737	●	1,60
1582740	●	1,70
1582744	●	1,80
1533082	●	2,00
1533086	●	2,10
1533089	●	2,30
1533094	●	2,40
1533098	●	2,5
1533102	●	2,60
1533105	●	2,70
1533107	●	2,80
1736981	●	2,90
1533113	●	3,00
1736988	●	3,50
1784882	●	4,10
1784884	●	4,20

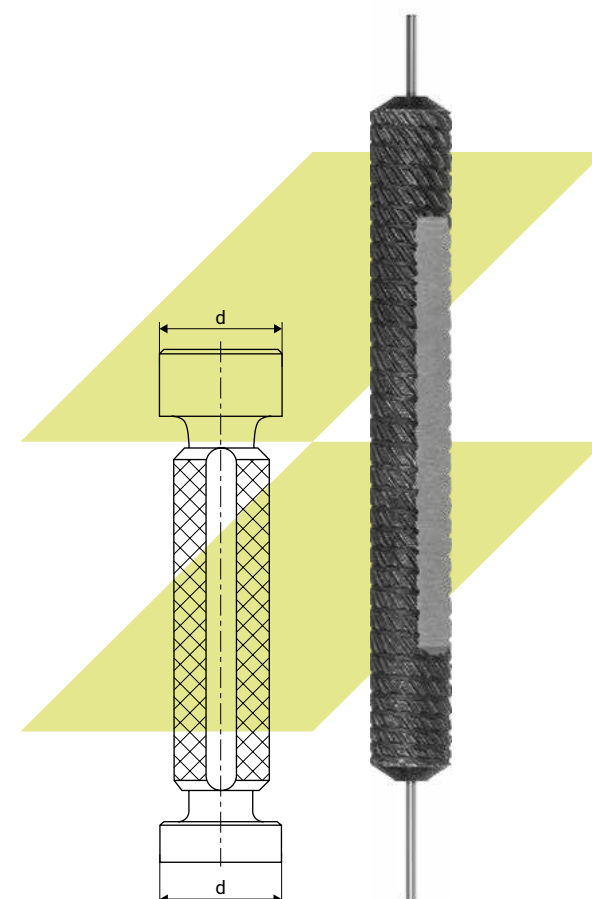

Калибр-пробки гладкие

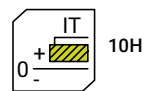

Артикул		d, мм
1784871	●	0,5
1582696	●	0,6
1582702	●	0,8
1582705	●	0,9
1582725	●	1,4
1582731	●	1,5
1582741	●	1,7
1784876	●	1,8
1737021	●	6,0

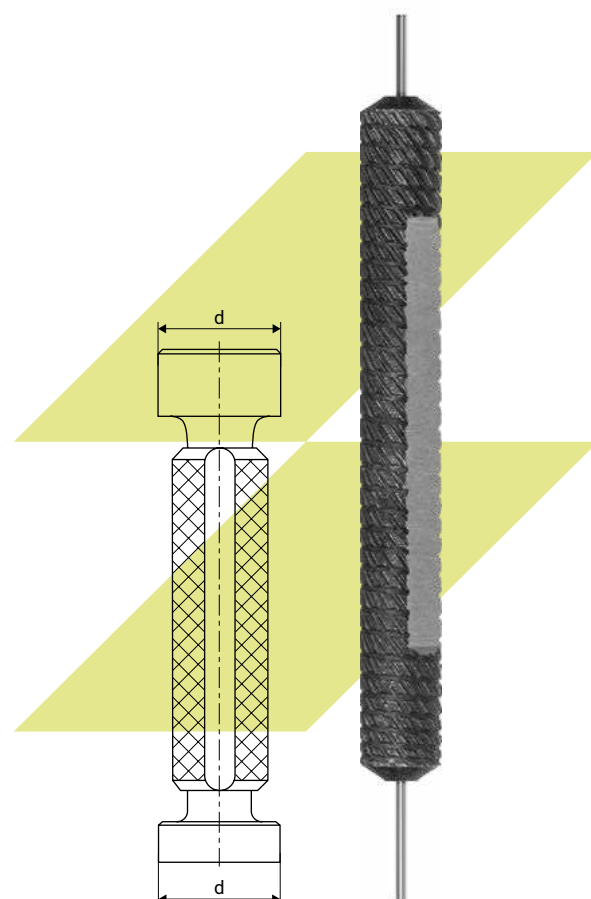

Калибр-пробки гладкие

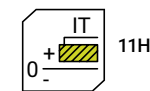

Артикул		d, мм
1582689	●	0,50
1582697	●	0,60
1582700	●	0,70
1582703	●	0,80
1763919	●	0,90
1582707	●	0,95
1582712	●	1,00
1582715	●	1,15
1784874	●	1,20
1736975	●	1,30
1582732	●	1,50
1582738	●	1,60
1736977	●	1,70
1736979	●	2,20
1533095	●	2,40
1533099	●	2,50
1784879	●	2,70
1533114	●	3,00
1736984	●	3,10
1784883	●	4,10
1729427	●	4,50
1737003	●	4,80
1737008	●	5,00
1737012	●	5,30

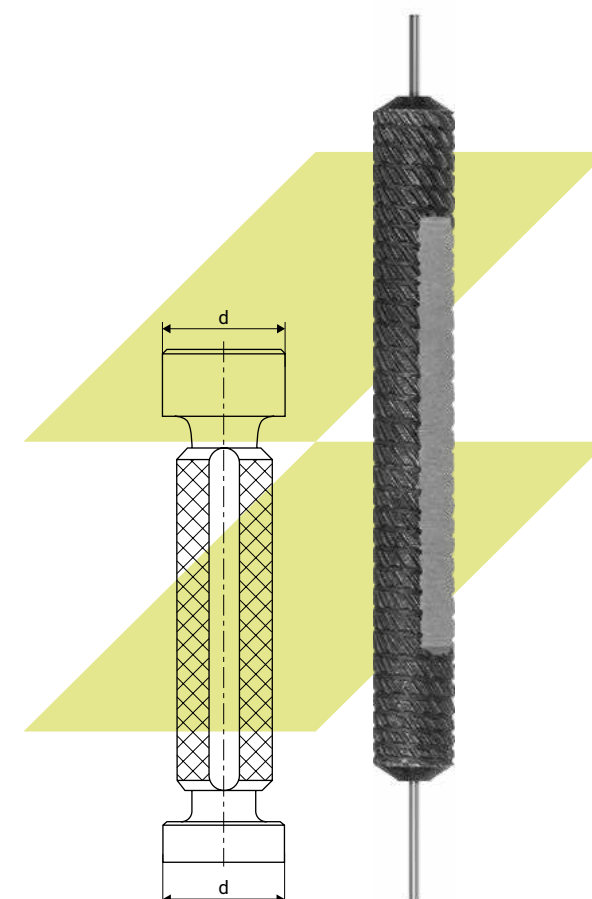

Калибр-пробки гладкие

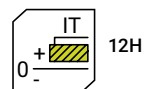

IT 12H

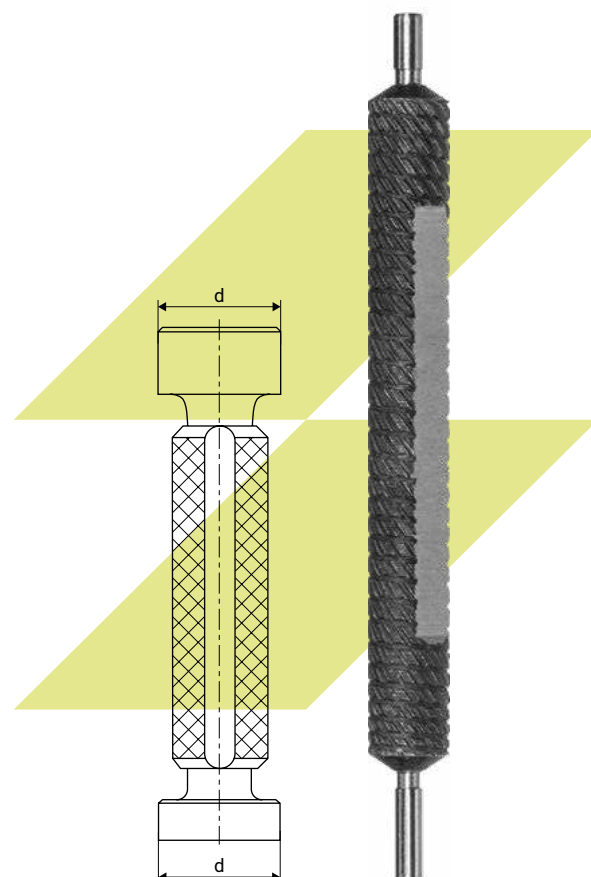

Артикул		d, мм
1582685	●	0,40
1582690	●	0,50
1582698	●	0,60
1582701	●	0,70
1582704	●	0,80
1582706	●	0,90
1582708	●	0,95
1582713	●	1,00
1736973	●	1,10
1582716	●	1,20
1582719	●	1,30
1582726	●	1,40
1582733	●	1,50
1582739	●	1,60
1582742	●	1,70
1582743	●	1,75
1582745	●	1,80
1533078	●	1,90
1533083	●	2,00
1533087	●	2,10
1736978	●	2,20
1533090	●	2,30
1533096	●	2,40
1533100	●	2,50
1533103	●	2,60
1533106	●	2,70
1533108	●	2,80
1533109	●	2,90
1533115	●	3,00
1736983	●	3,10
1736985	●	3,20
1736986	●	3,30
1736987	●	3,40
1736989	●	3,50

Артикул		d, мм
1736990	●	3,60
1736991	●	3,70
1736992	●	3,80
1784881	●	3,90
1736995	●	4,00
1736996	●	4,10
1736997	●	4,20
1736998	●	4,30
1736999	●	4,40
1737000	●	4,50
1737001	●	4,60
1737002	●	4,70
1737004	●	4,80

Артикул		d, мм
1737005	●	4,90
1737009	●	5,00
1737010	●	5,10
1737011	●	5,20
1737013	●	5,30
1737014	●	5,40
1737015	●	5,50
1737016	●	5,60
1737017	●	5,70
1737018	●	5,80
1737019	●	5,90
1737022	●	6,00

Калибр-пробки гладкие



ГОСТ
21401-75



Проходные-
непроходные
ПР и НЕ



IT
14H

Артикул		d, мм
1582714	●	1,0
1533084	●	2,0
1533097	●	2,4
1784878	●	2,6
1533116	●	3,0
1729428	●	5,0
1729429	●	6,0

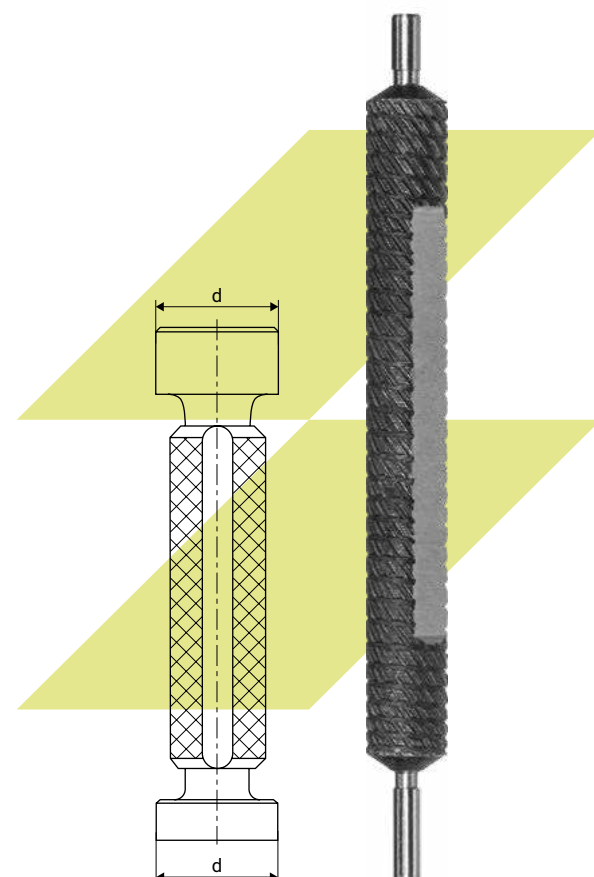

Для заметок

Series of horizontal dashed lines for taking notes.

Средства допускового контроля

Средства допускового контроля



Слесарно-монтажный инструмент

Ключи гаечные	808
Торцевые головки	825
Отвертки	826
Напильники и надфили	831
Шарнирно-губцевый инструмент	849
Полотна ручные	858
Ударно-рычажный инструмент	860
Ударно-режущий инструмент	867
Столярный инструмент	880
Электропаяльники	882

Ключи гаечные

Гаечные ключи предназначены для работы с широким спектром крепежа. Полированное хромированное покрытие надежно защищает корпус и исключает возникновение коррозии. Ключи выполнены из качественной стали, что обеспечивает высокую стойкость к износу и долгий срок службы.



Торцевые головки

Торцевые головки предназначены для работы, как с метрическим, так и с дюймовым крепежом. Изготовлены из хромованадиевой стали методом холодной штамповки с последующей термообработкой. Торцевые головки закалены, защищены от коррозии хромированием. Не боятся высоких и длительных нагрузок. Специальная рифленая накатка на основании головок улучшает сцепные характеристики и исключает проскальзывание в руках.



Отвертки

Отвертки используются для закручивания/откручивания крепежа средних размеров. Имеют оптимальную длину стержня для работы с обычными и заглубленными винтами. Простая конструкция и удобная рукоятка упрощают использование. Мягкость материала исключает натирание ладони и обеспечивает длительную работоспособность.



Напильники и надфили

Напильники и надфили используются при слесарных работах для опилования различных поверхностей и подгонки металлических деталей, зачистке клемм, обработке небольших отверстий или мелких пазов. Эргономичная форма рукоятки гарантирует надежный захват. Изготовлены из высококачественной стали, что обеспечивает прочность и износостойкость инструмента.



Шарнирно-губцевый инструмент

Шарнирно-губцевый инструмент предназначен для проведения слесарных работ, удержания деталей или перекусывания проволоки, а также для резки металлических заготовок, изделий из стали разных марок с большим диапазоном толщины. Инструмент подходит для работы с крепежными элементами или метизами. Губки изготовлены из качественной высокоуглеродистой стали высокочастотной закалки, что обеспечивает прочность и долговечность.



Полотна ручные

Ручное полотно используется для распиловки и обработки стали, мягких металлов, таких как медь и алюминий. Мелкие зубцы инструмента обеспечивают быструю скорость пиления и точный распил с чистым и ровным срезом.



Ударно-рычажный инструмент

Ударно-рычажный инструмент предназначен для демонтажа конструкций, правки металлических заготовок и листов (деформации или выпрямления), выполнении строительных работ, а также для забивания свай. Стальной боек отличается прочностью и устойчивостью к деформации, что позволяет выполнять сложные работы и обеспечивает долгий срок службы.



Ударно-режущий инструмент

Ударно-режущий инструмент предназначен для создания отверстий и отметок в бетоне, железобетоне, кирпиче и других подобных материалах. Изготовлен из специального ударопрочного сплава, благодаря чему выдерживает ударные нагрузки и обладает значительным рабочим ресурсом. Специальная конструкция спирали позволяет быстро отводить буровую пыль от места сверления.



Столярный инструмент

Стамески используются для чистого и ровного реза, а также создания пазов и углублений в заготовках из древесины. С их помощью производят строгание, снятие фасок, зачистку, выборку углублений и др. Рабочая часть изготовлена из инструментальной стали, что обеспечивает прочность и износостойкость лезвия.



Электропаяльники

Электропаяльники применяются для ручного монтажа/демонтажа электронных компонентов и других мелких деталей. Позволяют соединять между собой мелкие детали при помощи нагрева. Цельное медное жало обеспечивает быстрый нагрев за 5 минут. Компактная рукоятка удобно удерживается в руке. Для питания требуется стандартная сеть.



Условные обозначения



Обозначение стандарта



Обозначение инструментального материала



Вид рукоятки



Твёрдость клейма

Профиль напильника/надфиля



Круглый



Полукруглый



Ножовочный



Квадратный



Ромбический



Овальный



Плоский



Трёхгранный



Трёхгранный односторонний

Наличие инструмента

● На складе в Нижнем Новгороде

○ Под заказ

Обозначения



Цифровые



Кириллица



Буквенные



Латиница

Профиль молотка



Круглый



Квадратный

Ключи гаечные

	Для круглых шлицевых гаек	Шарнирные для круглых шлицевых гаек	Торцевые односторонние прямые	Торцевые двусторонние прямые	Торцевые двусторонние изогнутые
Стандарт	ГОСТ 16984-79	-	-	-	-
Тип	-	-	-	-	-
Диапазон	22 – 170	22–220	12–32	19–38	8–36
Страница	808	809	810	811	812



	Рожковые односторонние	Рожковые двусторонние для ЗИП	Рожковые односторонние ударные	Накидные односторонние прямые ударные	Разводные
Стандарт	-	ГОСТ 2839-80	-	-	-
Тип	-	-	-	-	-
Диапазон	30–110	4–60	24–80	17–95	0–46
Страница	813	814	815	816	817



Ключи гаечные

	Разводные	Двусторонние коленчатые накидные	Трубные	Трубчатые двусторонние	С наружным шестигранником
Стандарт	-	-	-	ГОСТ 25789-83	-
Тип	1000 В	-	-	-	-
Диапазон	0–30	6–55	№0–№5	7–62	2–24
Страница	818	819	820	821	822

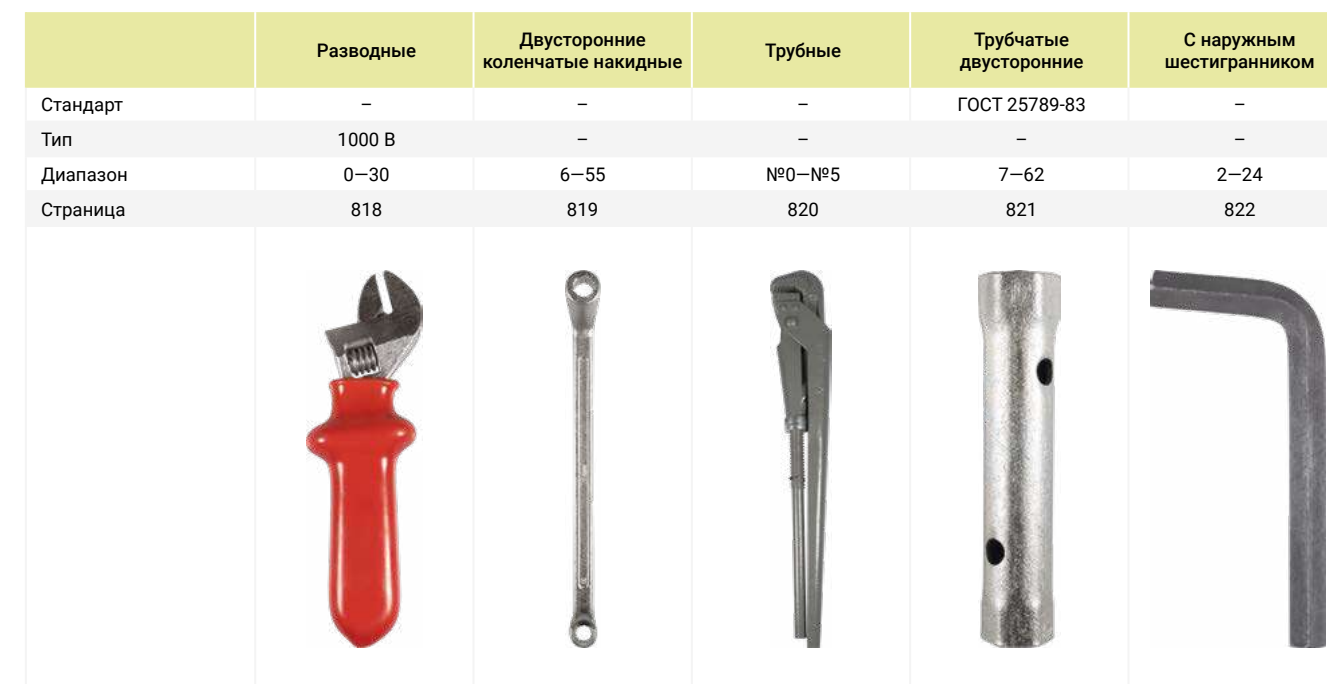

Ключи гаечные

	С наружным шестигранником для ЗИП	Комбинированные
Стандарт	ГОСТ 11737-93	-
Тип	-	-
Диапазон	4–22	5–70
Страница	823	824

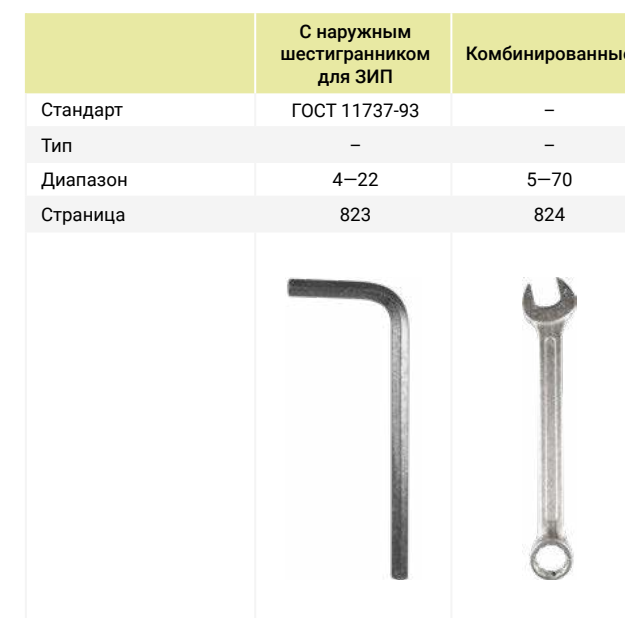

Торцевые головки



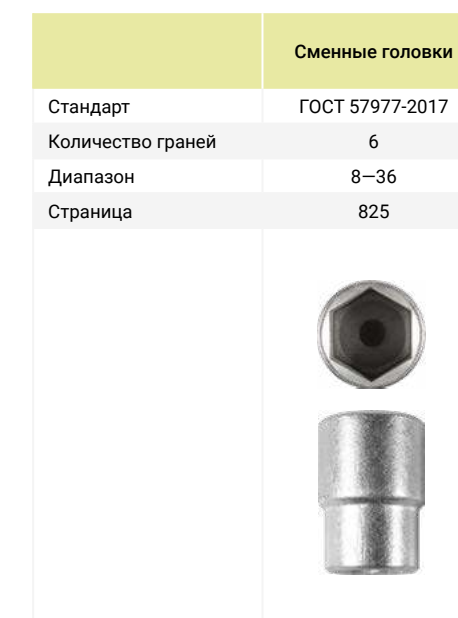



	Сменные головки
Стандарт	ГОСТ 57977-2017
Количество граней	6
Диапазон	8–36
Страница	825









Отвертки







	Шлицевые		Крестовые	
	ГОСТ 17199-88	ГОСТ 21010-75	ГОСТ 17199-88	ГОСТ 21010-75
Стандарт	ГОСТ 17199-88	ГОСТ 21010-75	ГОСТ 17199-88	ГОСТ 21010-75
Тип	1000 В		1000 В	
Страница	826	828	829	830
				

Напильники, надфили

	Напильники			Надфили		
	ГОСТ 1465-80	ГОСТ 1465-80	ГОСТ 1465-80	ГОСТ 1513-77	ГОСТ 1513-77	ГОСТ 1513-77
Стандарт	ГОСТ 1465-80	ГОСТ 1465-80	ГОСТ 1465-80	ГОСТ 1513-77	ГОСТ 1513-77	ГОСТ 1513-77
Материал	У13	У13	У13	У13	У13	У13
Тип	ромбические	трехгранные	Квадратные	Круглые	Полукруглые	Овальные
Страница	837	838	839	840	841	842
						

Напильники, надфили

	Напильники					
	ГОСТ 1465-80	ГОСТ 1465-80	ГОСТ 1465-80	ГОСТ 1465-80	ГОСТ 1465-80	ГОСТ 1465-80
Стандарт	ГОСТ 1465-80	ГОСТ 1465-80	ГОСТ 1465-80	ГОСТ 1465-80	ГОСТ 1465-80	ГОСТ 1465-80
Материал	У13	У13	У13	У13	У13	У13
Тип	квадратные	круглые	круглые	плоские остроносые	плоские тупоносые	полукруглые
Страница	831	832	833	834	835	836
						

	Надфили					
	ГОСТ 1513-77	ГОСТ 1513-77	ГОСТ 1513-77	ГОСТ 1513-77	ГОСТ 1513-77	ГОСТ 1513-77
Стандарт	ГОСТ 1513-77	ГОСТ 1513-77	ГОСТ 1513-77	ГОСТ 1513-77	ГОСТ 1513-77	ГОСТ 1513-77
Материал	У13	У13	У13	У13	У13	У13
Тип	Плоские остроносые	Плоские тупоносые	Ромбические	Трехгранные	Трехгранные односторонние	Ножовочные
Страница	843	844	845	846	847	848
						

Шарнирно-губцевый инструмент

Тип	Плоскогубцы				Кусачки торцевые
	радиотехнические	регулируемые	1000 В		
Страница	849	850	851	852	853
					

Полотна

Материал	Полотна ручные односторонние	
	Р6М5	Х6ВФ
Страница	858	859
		

Тип	Кусачки торцевые	Кусачки боковые		Ножницы по металлу
	1000 В		1000 В	леворежущие
Страница	854	855	856	857
				

Ударно-рычажный инструмент

Стандарт	Молотки с квадратный бойком			Молотки с круглым бойком			Кувалды
	ГОСТ 2310-77	ГОСТ 2310-77	ГОСТ 2310-77	—	ГОСТ 2310-78	—	—
Тип						искробезопасные	Тупоносые
Вес, кг	0,2–1	0,1–1	0,1–0,8	0,4–0,8	0,2–1	0,2–0,4	1,0–10,0
Страница	860	861	862	863	864	865	866
							

Ударно-режущий инструмент

Материал	Буры	Клейма				
		Твердый сплав	Сталь инструментальная	Твердый сплав	Сталь инструментальная	Сталь инструментальная
Тип	SDSplus	Цифровые	Цифровые	Буквенные	Буквенные	Цифровые
Диапазон	5–25	0–9	0–9	A–Я	A–Я A–Z	0–9
Страница	867	868	869	870	871	872
						

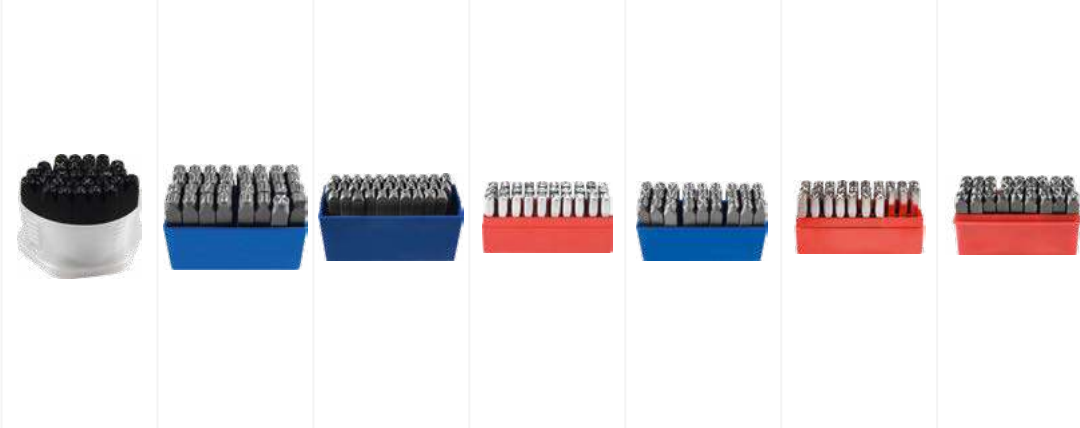
Материал	Клейма						
	Твердый сплав	Сталь инструментальная	Сталь инструментальная	Сталь инструментальная	Сталь инструментальная	Сталь инструментальная	Сталь инструментальная
Тип	Буквенные	Буквенные	Буквенные	Буквенные	Буквенные	Буквенные	Буквенные
Диапазон	A–Я	A–Я	A–Я	A–Я	A–Z	A–Z	A–Z
Страница	873	874	875	876	877	878	879
							

Столярный инструмент

Тип	Стамески	Стамески-долота
	Плоские	
Диапазон	8–32	10–30
Страница	880	881
		

Электропаяльники

Вид рукоятки	Электропаяльники нихромовые	
	пластиковая	деревянная
Страница	882	883
		

Ключи гаечные для круглых шлицевых гаек



Производитель: ООО «КЗСМИ»

Артикул	Обозначение по ГОСТ	D, мм		L, мм
		min	max	
1111779	—	22	26	150
1583410	7811-0315	30	34	155
1583411	7811-0316	38	42	165
1583412	7811-0317	45	52	190
1583413	7811-0418	55	60	215
1583414	7811-0319	65	70	240
1583415	7811-0320	75	85	270
1583416	7811-0422	90	95	290
1583417	7811-0423	100	110	315
1583418	7811-0424	115	120	340
1583419	7811-0425	125	130	350
1583420	7811-0428	165	170	420

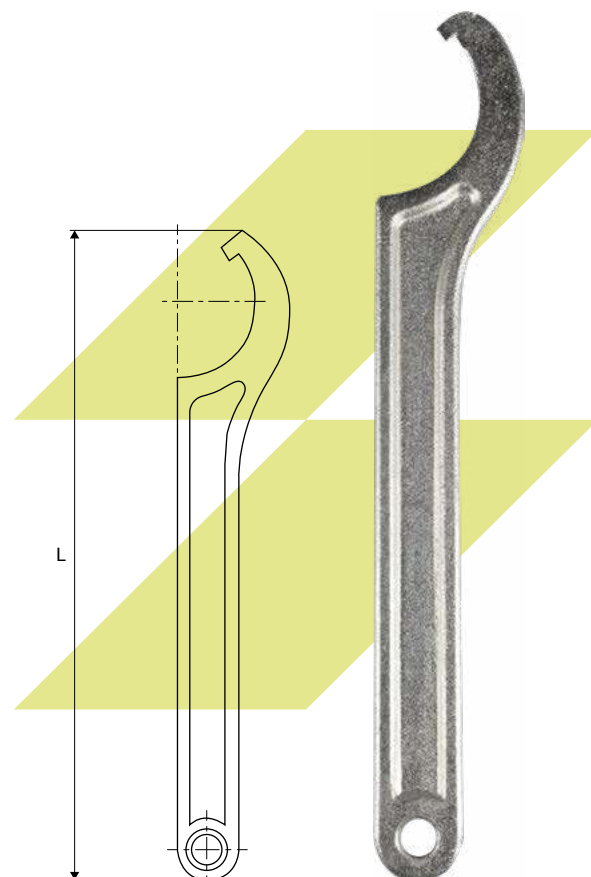

Шарнирные ключи для круглых шлицевых гаек

Производитель: ООО «КЗСМИ»

Артикул		D, мм		L, мм
		min	max	
1583908	●	22	60	160
1583909	●	65	110	250
1583910	●	115	220	400

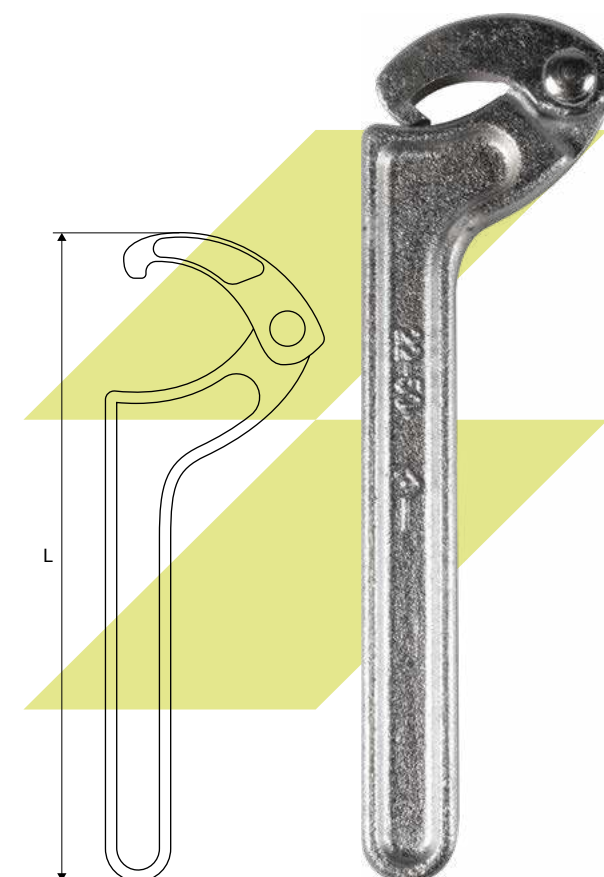

Ключи торцевые односторонние прямые

Артикул		S, мм	L, мм
1585759	●	12	205
1585760	●	14	130
1614479	●	15	240
1614480	●	17	240
1584517	●	19	400
1585761*	●	24	250
1585741	●	27	270
1584518	●	32	220
1639804	●	32	360

*С квадратом

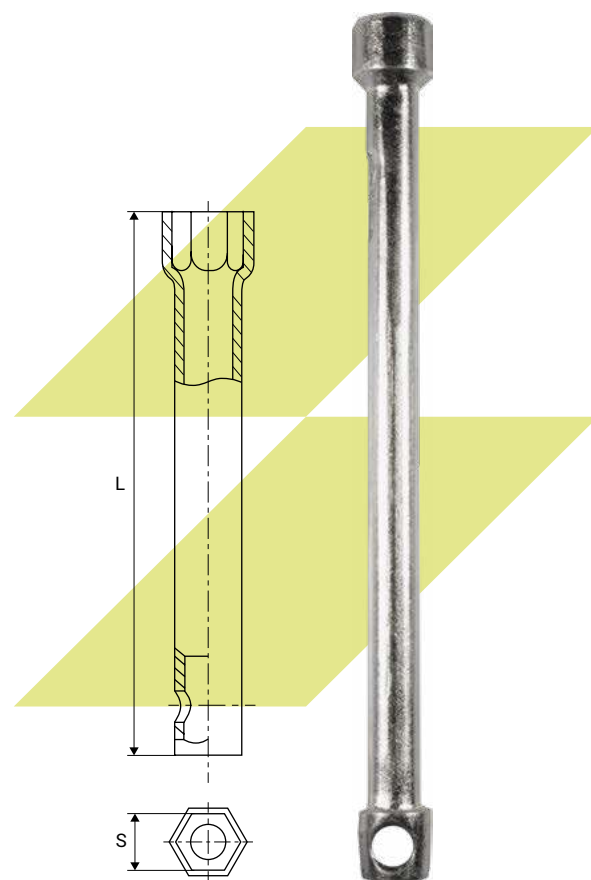

Ключи торцевые двусторонние прямые

Производитель: ООО «КЗСМИ»

Артикул		S1, мм	S2, мм	L, мм
1585767	●	19	22	240
1343044	●	22	38	290
1585768	●	24	27	360
1585769	●	24	27	380
1585791	●	24	38	290
1585770	●	24	38	450
1584509	●	27	30	390
1585771	●	27	32	420
1585772	●	27	32	580
1584510	●	30	32	280
1585773	●	30	32	430
1585774	●	30	32	470
1585792	●	30	36	280
1585793	●	30	36	600
1585777	●	30	41	360
1585794	●	32	33	400
1584511	●	32	36	515
1585775	●	32	38	400
1585776	●	32	38	500

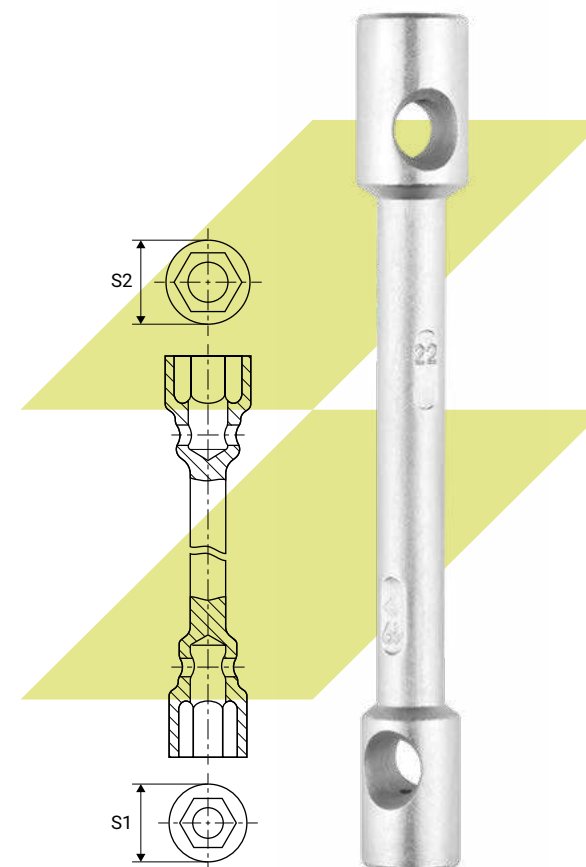

Ключи торцевые двусторонние изогнутые

Производитель: ООО «КЗСМИ»

Артикул		S1, мм	S2, мм
1584512	●	8	10
1584513	●	9	11
1585762	●	10	12
1584514	●	10	13
1102836	●	11	11
117756	●	12	13
1585764	●	12	13
1585765	●	13	14
115917	●	14	14
1584515	●	14	15
1336284	●	15	15
1336285	●	16	16
1585766	●	17	19
1336286	●	18	18
1584516	●	23	24
1336290	●	24	24
1336291	●	27	27
1124251	●	36	36

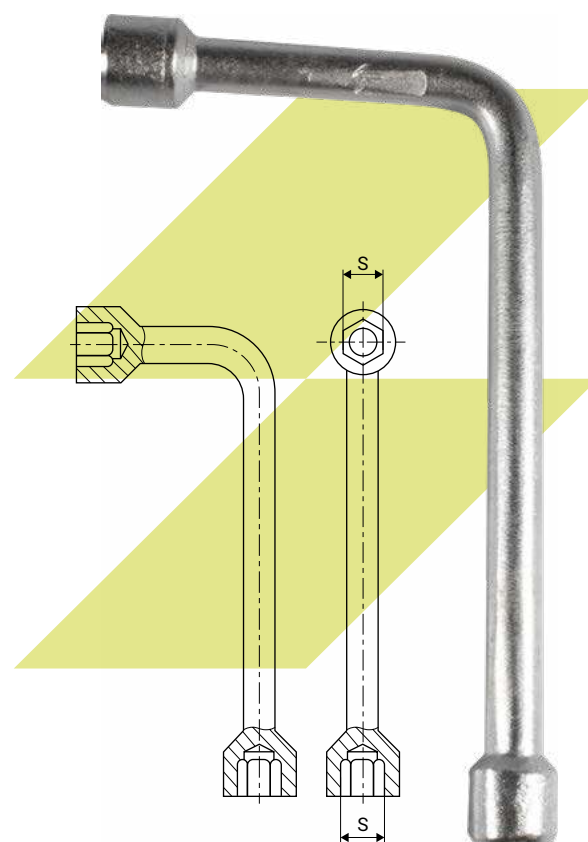

Ключи рожковые односторонние

Производитель: ООО «КЗСМИ»

Артикул		S, мм	L, мм
1584529	●	30	160
1583882	●	32	170
1583883	●	36	181
1583884	●	41	190
1583885	●	46	201
1583886	●	50	220
1583887	●	55	240
1583888	●	60	261
1583889	●	65	280
1583890	●	70	300
1583891	●	75	300
1583892	●	80	410
1583893	●	85	410
1583894	●	90	420
1583896	●	100	455
1583897	●	105	400
1583898	●	110	420

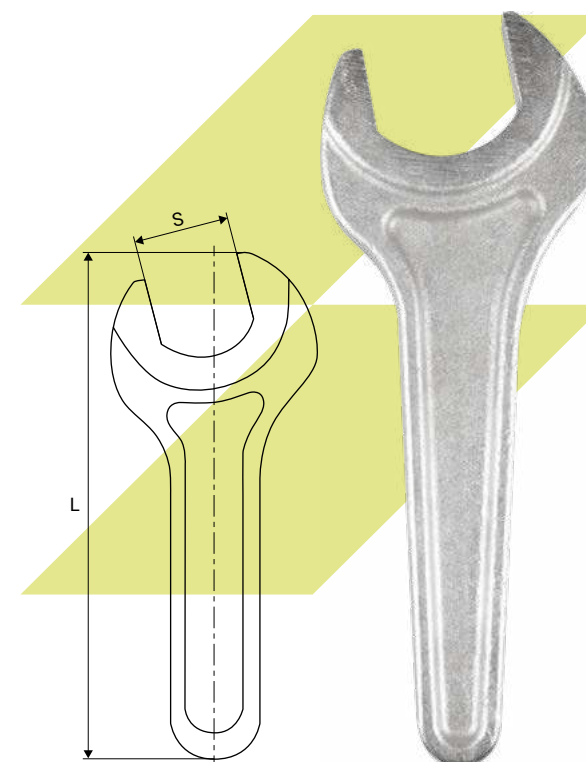

Ключи рожковые двусторонние для ЗИП



ГОСТ
2839-80

Производитель: ООО «КЗСМИ»

Артикул	Обозначение по ГОСТ	S1, мм	S2, мм	L, мм
1269551	7811-0001	4,0	5	80
1269552	7811-0002	5,5	7	100
1269555	7811-0455	8,0	9	110
1269554	7811-0003	8,0	10	120
1269556	7811-0456	9,0	11	125
1269539	7811-0004	10,0	12	125
1269540	7811-0461	11,0	13	140
1269541	7811-0007	12,0	13	140
1269542	7811-0021	12,0	14	140
1269543	7811-0027	13,0	14	140
1582175	7811-0463	13,0	15	160
1269544	7811-0464	13,0	17	160
1269545	7811-0022	14,0	17	160
1269546	7811-0023	17,0	19	175
1269547	7811-0024	19,0	22	205
1582176	7811-0477	21,0	22	205
1269548	7811-0025	22,0	24	220
1584496	7811-0467	22,0	27	230
1269549	7811-0026	24,0	27	250
1269550	7811-0041	27,0	30	260
1326093	7811-0042	30,0	32	280
1276304	7811-0043	32,0	36	310
1335911	7811-0044	36,0	41	350
1335912	7811-0045	41,0	46	380
1335839	7811-0046	46,0	50	420
1346034	7811-0047	50,0	55	460
1584497	7811-0048	55,0	60	500

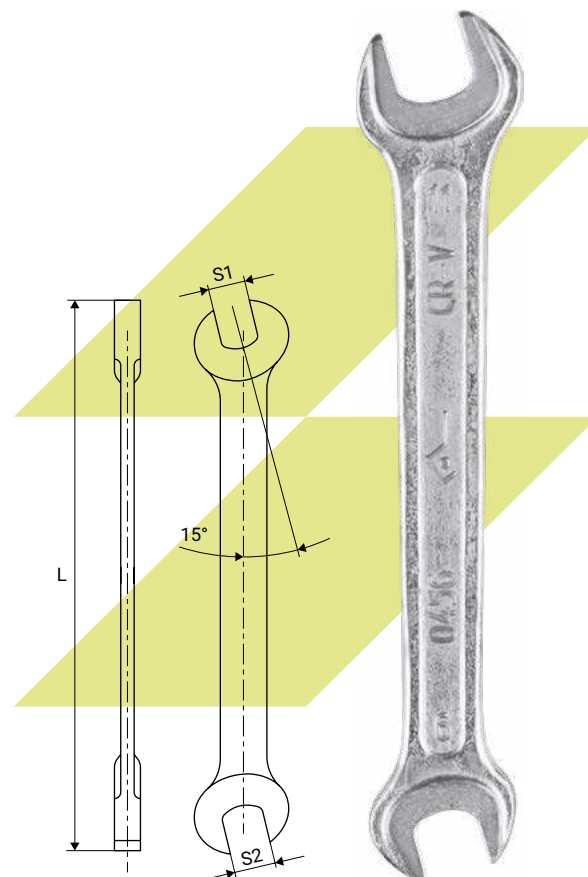

Ключи рожковые односторонние ударные

Производитель: ООО «КЗСМИ»

Артикул	S, мм	L, мм
1585745	24	175
1585746	27	175
1585747	30	195
1585748	32	195
1585749	36	220
1585750	41	240
1585751	46	240
1585752	50	275
1585753	55	275
1585754	60	310
1585755	65	310
1585756	70	360
1585757	75	360
1585758	80	385

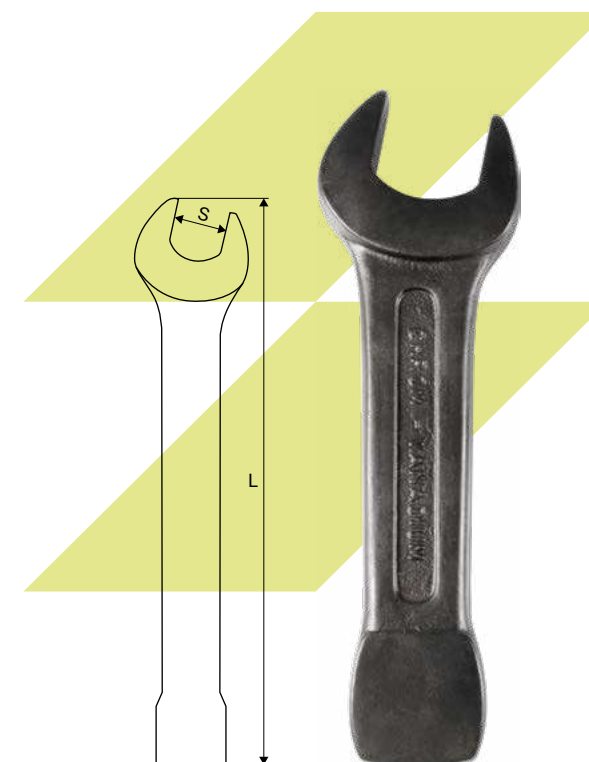

Ключи накладные односторонние прямые ударные

Производитель: ООО «КЗСМИ»

Артикул		S, мм		L, мм
		min	max	
1583911	●	17		140
1583912	●	19		140
1583913	●	22		160
1583914	●	24		160
1583915	●	27		175
1583916	●	30		175
1583917	●	32		225
1583918	●	36		225
1583919	●	38		225
1583920	●	41		240
1583921	●	46		240
1583922	●	50		282
1583923	●	55		282
1583924	●	60		313
1583925	●	65		313
1583926	●	70		335
1583927	●	75		335
1583928	●	80		360
1583929	●	85		360
1583930	●	90		400
1583931	●	95		400

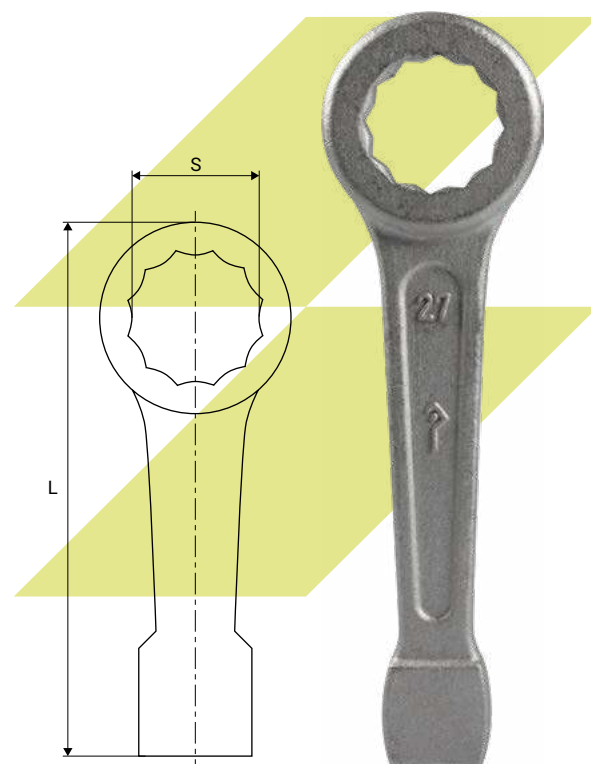

Ключи разводные

Производитель: ООО «НИЗ»

Артикул		S, мм		L, мм
		min	max	
117862	●	0	19	150
113053	●	0	30	250
113055	●	0	46	375

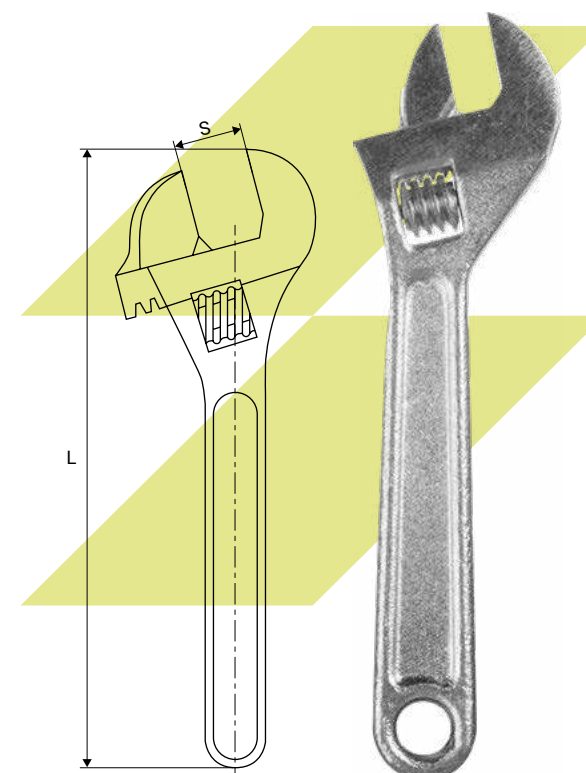

Ключи разводные диэлектрические



Производитель: ООО «НИЗ»

Артикул		S, мм		L, мм
		min	max	
1425747	●	0	19	155
1379458	●	0	30	255

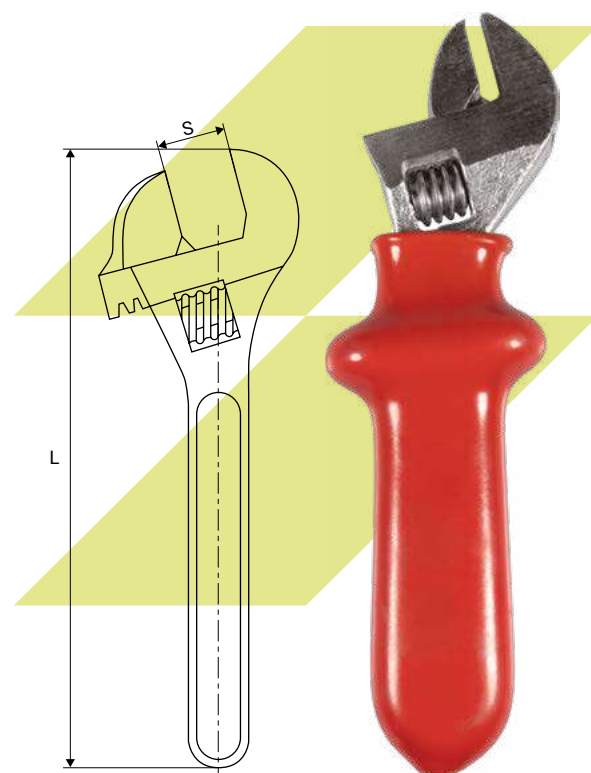

Ключи двусторонние коленчатые накидные

Производитель: ООО «КЗСМИ»

Артикул		S1, мм	S2, мм	L, мм
1718442	●	6	7	127
1478554	●	6	8	127
1583458	●	8	9	200
1583459	●	8	10	206
113080	●	10	11	200
1583460	●	10	12	200
1583461	●	12	13	210
1583462	●	12	14	210
1583463	●	13	14	220
1583464	●	13	17	240
1583465	●	14	17	240
1343042	●	14	19	260
1583466	●	17	19	260
1583467	●	17	22	280
1583468	●	19	22	280
1583469	●	22	24	320
1583470	●	24	27	320
1583471	●	24	30	340
1583472	●	27	30	350
119355	●	27	32	360
1583473	●	30	32	360
1583474	●	32	36	370
1583475	●	36	38	540
1583476	●	36	41	540
1583477	●	41	46	540
1583478	●	46	50	540
1583479	●	50	55	540

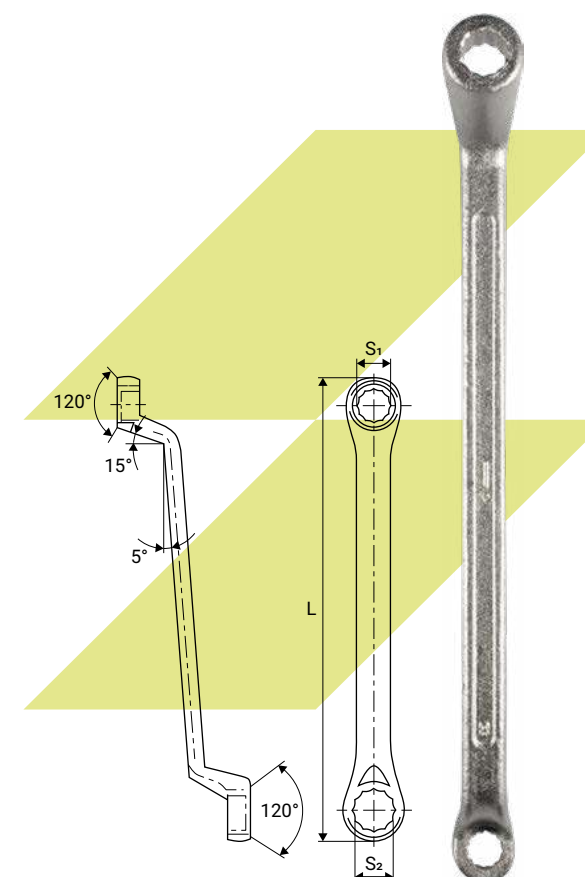

Ключи трубные

Производитель: ООО «НИЗ»

Артикул		Размер	L, мм
1144222	●	№0	250
1144223	●	№1	350
119087	●	№2	445
119086	●	№3	565
113174	●	№4	715
119085	●	№5	895

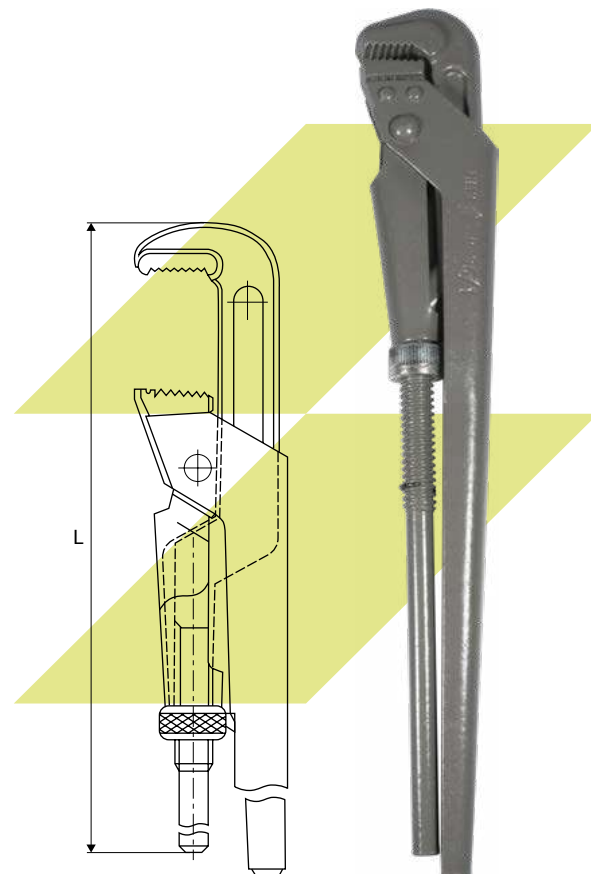

Ключи трубчатые двусторонние



ГОСТ
25789-83

Производитель: ООО «КЗСМИ»

Артикул		S1, мм	S2, мм	L, мм
1269709	●	7	8	95
1585778	●	8	10	95
1585779	●	10	12	105
1584530	●	12	13	105
1584531	●	14	15	105
1584532	●	17	19	115
1585782	●	50	62	130

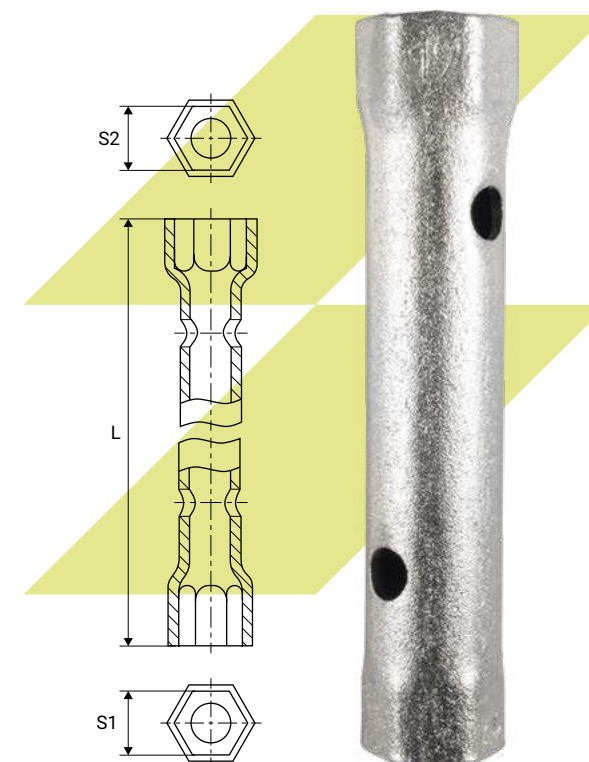

Ключи с наружным шестигранником

Артикул		S, мм
1137917	●	2,0
117433	●	2,5
1110359	●	3,0
115763	●	4,0
115764	●	5,0
117725	●	6,0
117434	●	7,0
113178	●	8,0
113179	●	10,0
1418666	●	11,0
113180	●	12,0
117278	●	14,0
117279	●	17,0
117280	●	19,0
117747	●	22,0
1109233	●	24,0

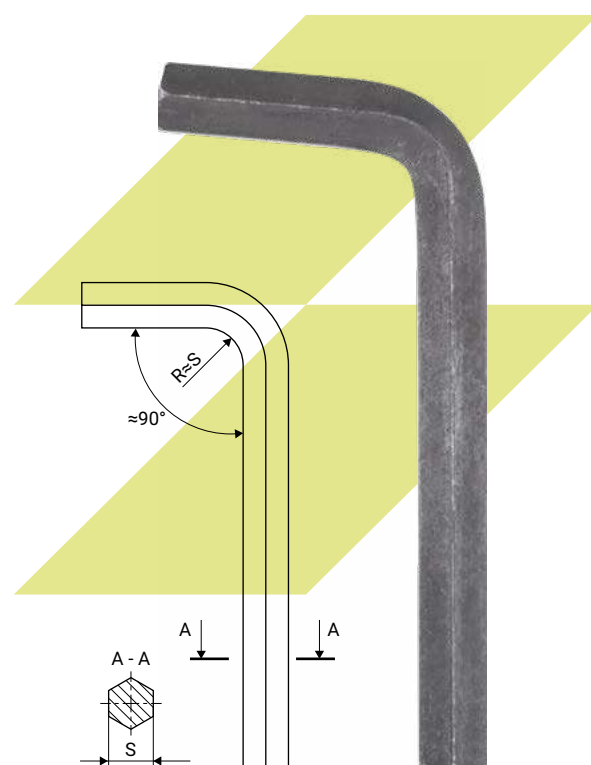

Ключи с наружным шестигранником для ЗИП



Артикул		Обозначение по ГОСТ	S, мм	L, мм
1584508	●	7812-0373	4,0	74
1284286	●	7812-0374	5,0	85
1284287	●	7812-0375	6,0	96
1284288	●	7812-0376	8,0	108
1284289	●	7812-0377	10,0	122
1284290	●	7812-0378	12,0	137
1284291	●	7812-0379	14,0	134
1416450	●	7812-0381	17,0	177
1614477	●	7812-0382	19,0	199
1614478	●	7812-0383	22,0	222

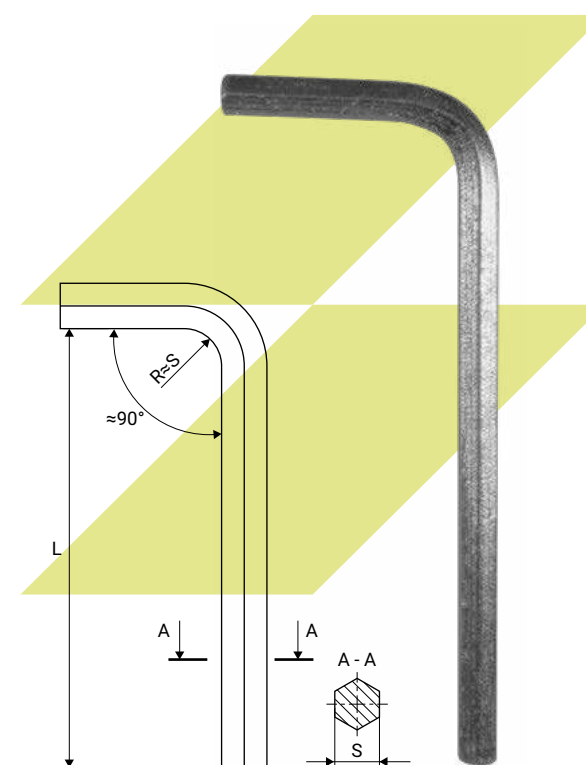

Ключи комбинированные

Производитель: ООО «КЗСМИ»

Артикул		S, мм	L, мм
1583421	●	5,0	110
1583422	●	5,5	110
1583423	●	6,0	110
1583424	●	7,0	139
1583425	●	8,0	139
1583426	●	9,0	144
1583427	●	10,0	149
1583428	●	11,0	155
1583429	●	12,0	161
1583430	●	13,0	167
1583431	●	14,0	173
1583432	●	15,0	179
1584401	●	16,0	179
1583433	●	17,0	193
1583434	●	18,0	200
1583435	●	19,0	207
1584404	●	20,0	207
1583436	●	21,0	231
1583437	●	22,0	231
1583438	●	23,0	231
1583439	●	24,0	248
1583440	●	27,0	276
1583441	●	30,0	307
1583442	●	32,0	318
1583443	●	36,0	348
1583444	●	41,0	370
1583445	●	46,0	400
1583446	●	50,0	460
1583447	●	55,0	460
1583448	●	60,0	470
1583449	●	65,0	470
1583450	●	70,0	470

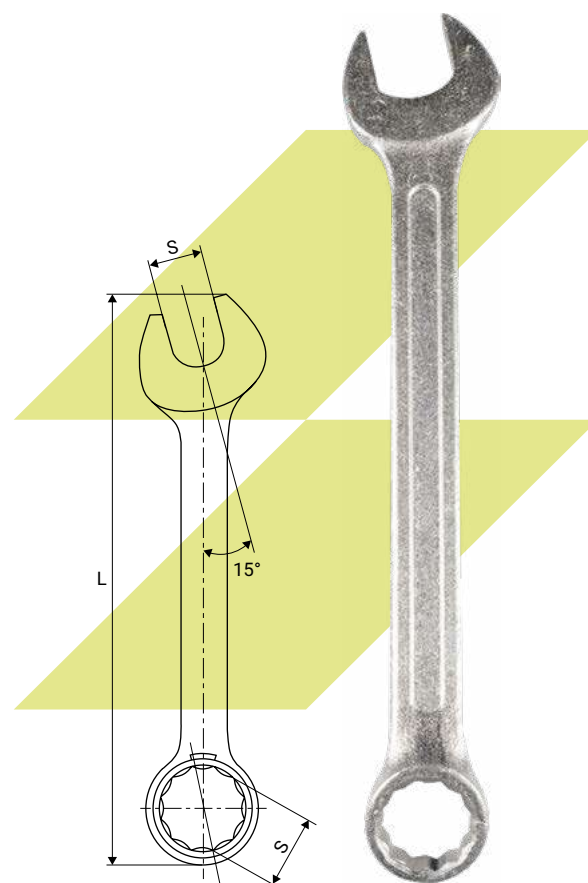

Сменные головки

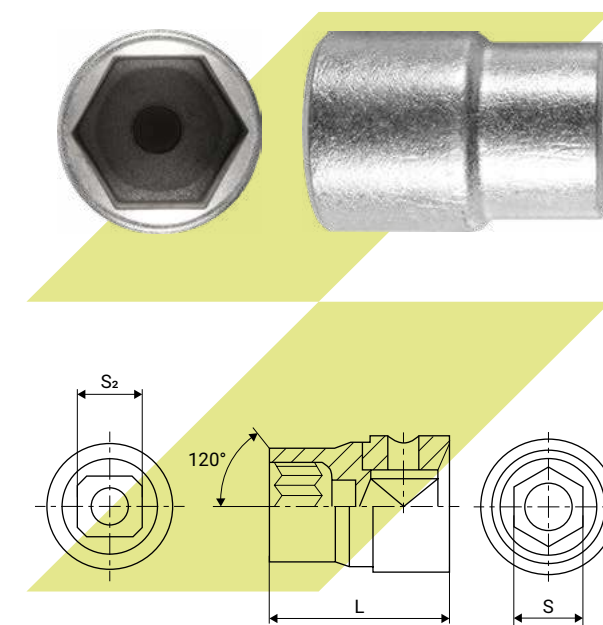

Артикул		Обозначение по ГОСТ	S, мм	S2, мм	L, мм
112919	●	—	9	1/2	32
112920	●	7812-0483	10	1/2	32
112921	●	7812-0484	11	1/2	32
112922	●	7812-0485	12	1/2	32
112923	●	7812-0486	13	1/2	34
112924	●	7812-0487	14	1/2	34
1128857	●	—	14	3/8	—
112925	●	7812-0488	15	1/2	34
1128856	●	—	15	3/8	—
1177852	●	7812-0489	16	1/2	36
112926	●	7812-0491	17	1/2	36
118091	●	7812-0492	18	1/2	38
115915	●	7812-0493	19	1/2	38
118090	●	7812-0494	20	1/2	38
112927	●	7812-0496	22	1/2	40
112928	●	7812-0498	24	1/2	42
112929	●	7812-0502	27	1/2	45
112930	●	7812-0504	30	1/2	48
112931	●	7812-0505	32	1/2	50
1109533	●	—	36	1/2	—

Производитель: ООО «НИЗ»

Артикул		Обозначение по ГОСТ	S, мм	S2, мм	L, мм
112918	●	—	8	1/2	32
1582171	●	7812-0495	21	1/2	40
1582172	●	7812-0497	23	1/2	42
1582173	●	7812-0499	25	1/2	45
1582174	●	7812-0501	26	1/2	45

Отвертки шлицевые



ГОСТ
17199-88



Декоративная

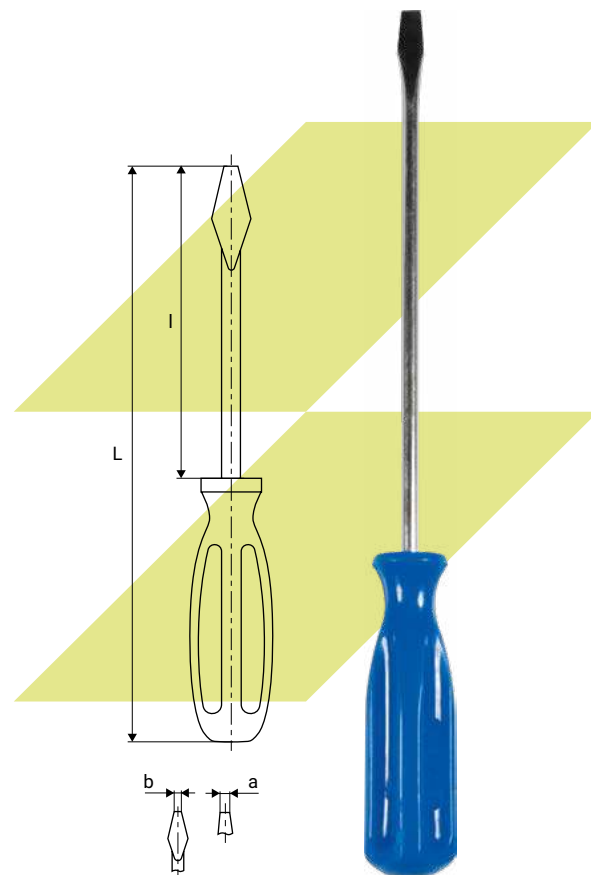

Производитель: ООО «НПП «Контур»

Артикул	Обозначение по ГОСТ	a × b	l, мм	L, мм
1477829	7810-1037	0,8 × 5,5	25	70
1477830	7810-1043	1,0 × 6,5	25	70
1477567	7810-0905	0,4 × 2,5	45	90
1477831	7810-0301	0,3 × 2,0	50	95
1643107	7810-0908	0,5 × 3,5	50	105
1477832	7810-0908	0,5 × 3,5	50	105
1477833	7810-0918	0,8 × 5,5	25	115
1477568	7810-0303	1,2 × 8,0	75	120
1477834	7810-0909	0,5 × 3,5	75	130
1477569	7810-0911	0,6 × 4,0	75	155
1477835	7810-0911	0,5 × 3,5	100	155
1477836	7810-0921	0,8 × 5,5	75	165
1477837	7810-0927	1,0 × 6,5	75	165
1477838	7810-0915	0,6 × 4,0	100	180
1477839	7810-0912	0,5 × 3,5	125	180
1477572	7810-0928	1,0 × 6,5	90	190
1477571	7810-0434	0,8 × 5,5	100	190
1107622	-	1,0 × 6,5	100	200
1477840	7810-0324	1,2 × 8,0	100	200
1477841	7810-1053	1,6 × 10,0	100	200
1477842	7810-0916	0,6 × 4,0	125	205
1477843	7810-1046	1,2 × 8,0	125	225
1477844	7810-0917	0,6 × 4,0	150	230
1477575	7810-0314	0,8 × 5,5	150	240
1643109	7810-0320	1,0 × 6,5	150	240
1477845	7810-0320	1,0 × 6,5	150	240
1477846	7810-0935	1,2 × 8,0	150	250
1477576	7810-0941	1,6 × 10,0	150	250
1477847	7810-0944	2,0 × 13,0	150	260
1477848	7810-1048	1,2 × 8,0	175	275
1477849	7810-1055	1,6 × 10,0	175	275
1643110	7810-0924	0,8 × 5,5	200	290
1477850	7810-0924	0,8 × 5,5	200	290
1477851	7810-0931	1,0 × 6,5	200	290

Артикул	Обозначение по ГОСТ	a × b	l, мм	L, мм
1477852	7810-0942	1,6 × 10,0	200	300
1477853	7810-0945	2,0 × 13,0	200	310
1477854	7810-0946	2,0 × 13,0	250	360

Производитель: ООО «КВТ»

Артикул	Обозначение по ГОСТ	a × b	l, мм	L, мм
77396	7810-1037	0,6 × 3,0	165	75
77397	7810-1043	0,6 × 4,0	190	100
77398	7810-0905	1,0 × 5,5	215	125
77399	7810-0301	1,0 × 6,5	252	150

Отвертки шлицевые диэлектрические



Производитель: ООО «НПП «Контур»

Артикул	Обозначение по ГОСТ	a × b	l, мм	L, мм
1477570	7810-0456	0,4 × 2,5	180	80
1477573	7810-0437	0,8 × 5,5	200	100
1477574	7810-0437	1,0 × 6,5	200	100

Производитель: ООО «КВТ»

Артикул	Обозначение по ГОСТ	a × b	l, мм	L, мм
78608	7810-0456	0,5 × 3,0	185	100
78609	7810-0437	0,8 × 4,0	190	100
78588	7810-0437	0,8 × 4,0	198	100
78610	7810-0437	1,0 × 5,5	225	125
78589	7810-0437	1,0 × 5,5	230	125
78587	7810-0437	0,6 × 3,5	248	100
78590	7810-0437	1,0 × 6,5	260	150

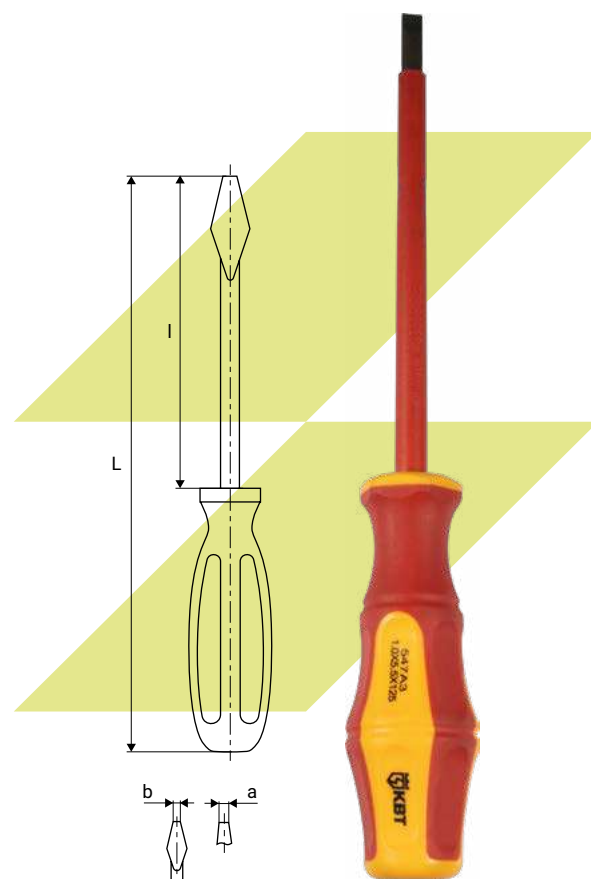

Отвертки крестовые



Производитель: ООО «НПП «Контур»

Артикул	Обозначение по ГОСТ	Крестообразная часть	l, мм	L, мм
1477577	7810-0975	№0	55	105
1477578	7810-0976	№0	75	130
1477855	7810-1034	№0	100	155
1477857	7810-0977	№1	25	115
1477858	7810-0978	№1	75	165
1477580	7810-0979	№1	100	190
1477582	7810-1041	№1	150	240
1477859	7810-1045	№2	25	70
1477860	7810-0981	№2	25	125
1477584	7810-0982	№2	100	200
1477861	7810-0983	№2	125	225
1477585	7810-1047	№2	150	250
1477862	7810-0984	№3	25	125
1477863	7810-1054	№3	100	200
1477586	7810-0985	№3	150	250

Производитель: ООО «КВТ»

Артикул	Обозначение по ГОСТ	Крестообразная часть	l, мм	L, мм
77400	7810-0975	№0	75	165
77401	7810-0976	№1	100	190
77402	7810-1034	№2	125	227
77404	7810-0977	№2	125	227

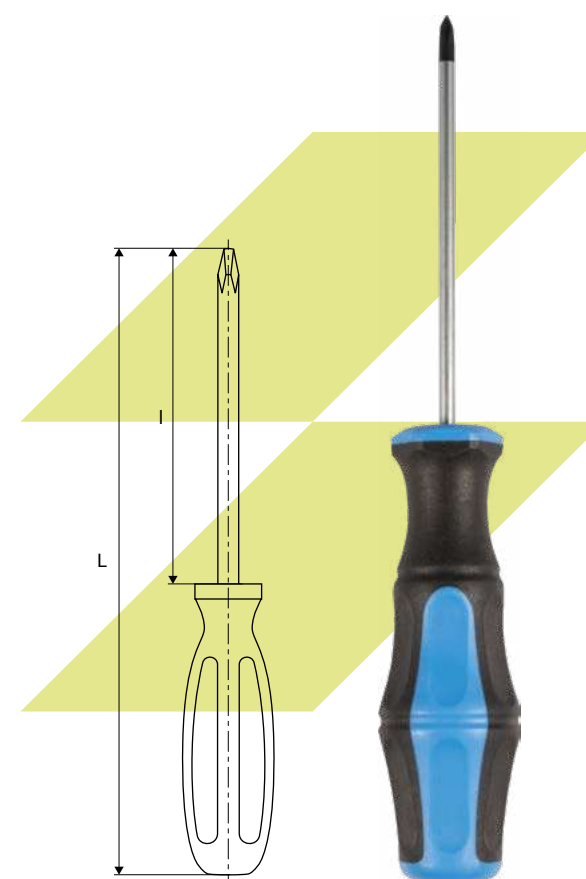

Отвертки крестовые диэлектрические



ГОСТ
21010-75



Изолированные
1000 В

Производитель: ООО «НПП «Контур»

Артикул	Обозначение по ГОСТ	Крестообразная часть	I, мм	L, мм
1477579	7810-1021	№0	80	180
1477581	7810-1023	№1	100	200
1477583	7810-1202	№2	100	200

Производитель: ООО «КВТ»

Артикул	Крестообразная часть	I, мм	L, мм
78611	№1	80	180
78583	№1	80	235
78612	№2	100	210
78584	№2	100	260
78613	№1	80	180
78585	№1	80	185
78586	№2	100	210
78614	№2	100	210

ООО «НИЗ»

Артикул	Крестообразная часть	I, мм	L, мм
1582190	№1	90	180
1582191	№2	115	220
1582192	№3	132	250

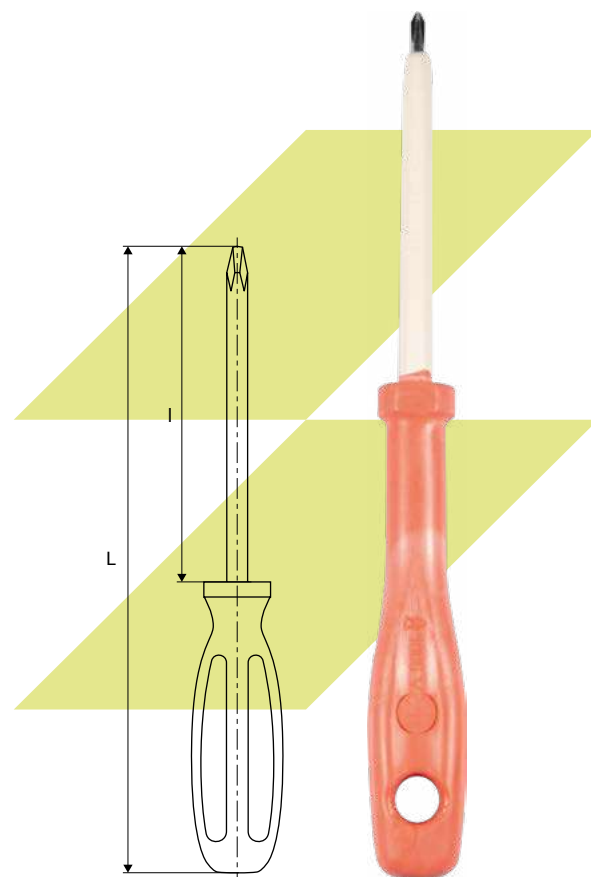

Напильники квадратные



ГОСТ
1465-80



У13



Квадратный

Артикул	Обозначение по ГОСТ	Номер насечки	b, мм	I, мм	L, мм
1220415	2821-0001	1	4	100	140
1220416	2821-0002	2	4	100	140
1220417	2821-0003	3	4	100	140
1220418	2821-0011	1	6	150	200
1220419	2821-0012	2	6	150	200
1220420	2821-0013	3	6	150	200
1220421	2821-0016	1	8	200	255
1220422	2821-0017	2	8	200	255
1220423	2821-0018	3	8	200	255
1220424	2821-0021	1	10	250	310
1220425	2821-0022	2	10	250	310
1269367	2821-0023	3	10	250	310
1220426	2821-0026	1	12	300	370
1220427	2821-0027	2	12	300	370
1269368	2821-0028	3	12	300	370
1220428	2821-0032	1	15	350	430
1220429	2821-0033	2	15	350	430
1220430	2821-0034	3	15	350	430
1220431	2821-0036	1	18	400	490
1220432	2821-0037	2	18	400	490
1220433	2821-0038	3	18	400	490

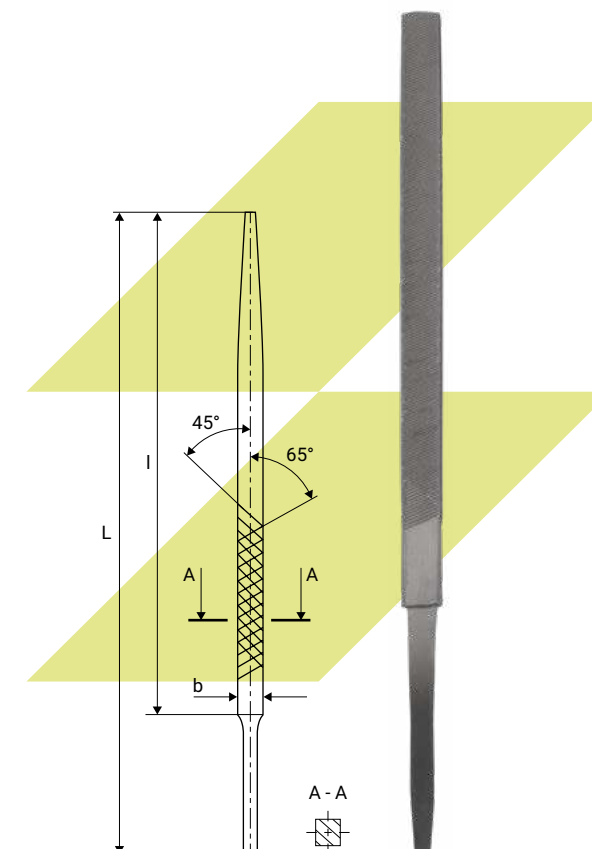

Напильники круглые с насеченными зубьями



ГОСТ
1465-80



У13



Круглый

Артикул	Обозначение по ГОСТ	Номер насечки	d, мм	l, мм	L, мм
1220434	2822-0001	1	4	100	140
1220435	2822-0002	2	4	100	140
1220436	2822-0003	3	4	100	140
1220437	2822-0011	1	6	150	200
1220438	2822-0012	2	6	150	200
1220439	2822-0013	3	6	150	200
1220440	2822-0016	1	7,5	200	255
1220441	2822-0017	2	7,5	200	255
1220442	2822-0018	3	7,5	200	255
1416442	2822-0019	4	7,5	200	255
1220443	2822-0021	1	9,5	250	310
1220444	2822-0022	2	9,5	250	310
1220445	2822-0023	3	9,5	250	310
1220446	2822-0026	1	12	300	370
1220447	2822-0027	2	12	300	370
1220448	2822-0028	3	12	300	370
1220449	2822-0036	1	18	400	490
1220450	2822-0037	2	18	400	490
1220451	2822-0038	3	18	400	490

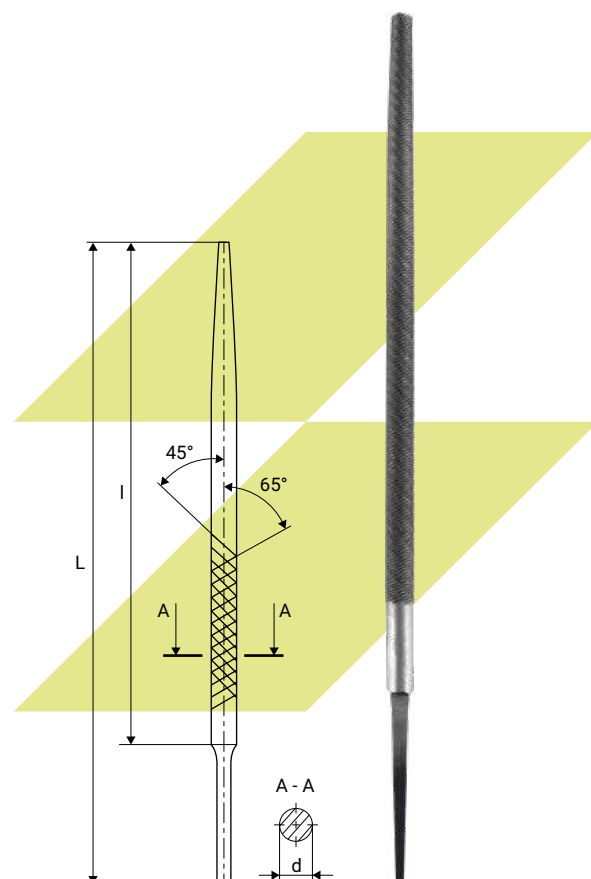

Напильники круглые с нарезными зубьями



ГОСТ
1465-80

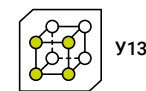

У13



Круглый

Артикул	Обозначение по ГОСТ	Номер насечки	d, мм	l, мм	L, мм
1258068	2822-0051	1	4	100	140
1253799	2822-0057	1	6	150	200
1254642	2822-0058	2	6	150	200
1254643	2822-0059	3	6	150	200
1254644	2822-0060	1	7,5	200	255
1254645	2822-0061	2	7,5	200	255
1254646	2822-0062	3	7,5	200	255
1254647	2822-0063	1	9,5	250	310
1253800	2822-0064	2	9,5	250	310
1256916	2822-0065	3	9,5	250	310
1102460	2822-0068	3	12	300	370
1253801	2822-0070	1	15	350	430
1253802	2822-0071	2	15	350	430
1254648	2822-0072	3	15	350	430
0103792	2822-0076	3	18	400	490

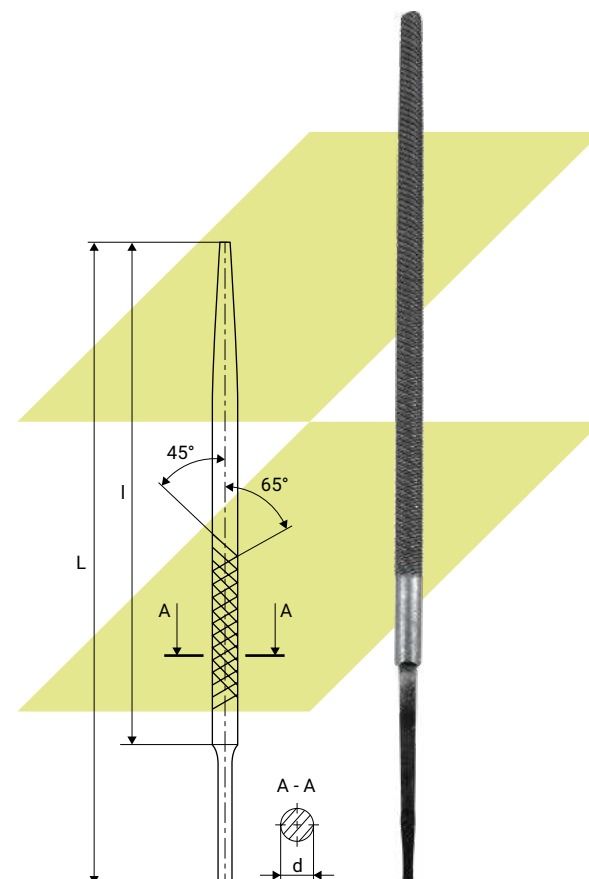

Напильники плоские остроносые



Артикул	Обозначение по ГОСТ	Номер насечки	b, мм	l, мм	L, мм
1220497	2820-0051	1	12	100	140
1220499	2820-0052	2	12	100	140
1220501	2820-0053	3	12	100	140
1220503	2820-0061	1	16	150	200
1220505	2820-0062	2	16	150	200
1220507	2820-0063	3	16	150	200
1220509	2820-0066	1	20	200	255
1220511	2820-0067	2	20	200	255
1220513	2820-0068	3	20	200	255
1220515	2820-0071	1	25	250	310
1220517	2820-0072	2	25	250	310
1220519	2820-0073	3	25	250	310
1220521	2820-0076	1	30	300	370
1220523	2820-0077	2	30	300	370
1220525	2820-0078	3	30	300	370
1287228	2820-0079	4	30	300	370
1220527	2820-0082	1	35	350	430
1220529	2820-0083	2	35	350	430
1220531	2820-0084	3	35	350	430
1220533	2820-0086	1	39	400	490
1220535	2820-0087	2	39	400	490
1220537	2820-0088	3	39	400	490
1254649	2820-0089	0	44	450	550

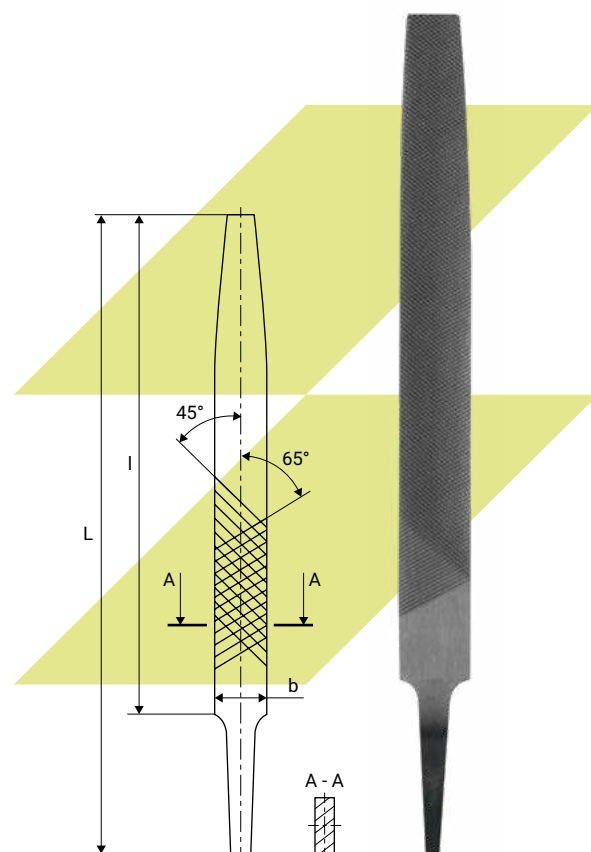

Напильники плоские тупоносые



Артикул	Обозначение по ГОСТ	Номер насечки	b, мм	l, мм	L, мм
1220498	2820-0001	1	12	100	140
1220500	2820-0002	2	12	100	140
1220502	2820-0003	3	12	100	140
1220504	2820-0011	1	16	150	200
1220506	2820-0012	2	16	150	200
1220508	2820-0013	3	16	150	200
1220510	2820-0016	1	20	200	255
1220512	2820-0017	2	20	200	255
1220514	2820-0018	3	20	200	255
1220516	2820-0021	1	25	250	310
1220518	2820-0022	2	25	250	310
1220520	2820-0023	3	25	250	310
0103810	2820-0024	4	25	250	310
1220522	2820-0026	1	30	300	370
1220524	2820-0027	2	30	300	370
1220526	2820-0028	3	30	300	370
0113738	2820-0029	4	30	300	370
1220528	2820-0032	1	35	350	430
1220530	2820-0033	2	35	350	430
1220532	2820-0034	3	35	350	430
1220534	2820-0036	1	39	400	490
1220536	2820-0037	2	39	400	490
1220538	2820-0038	3	39	400	490
1254650	2820-0039	0	44	450	550

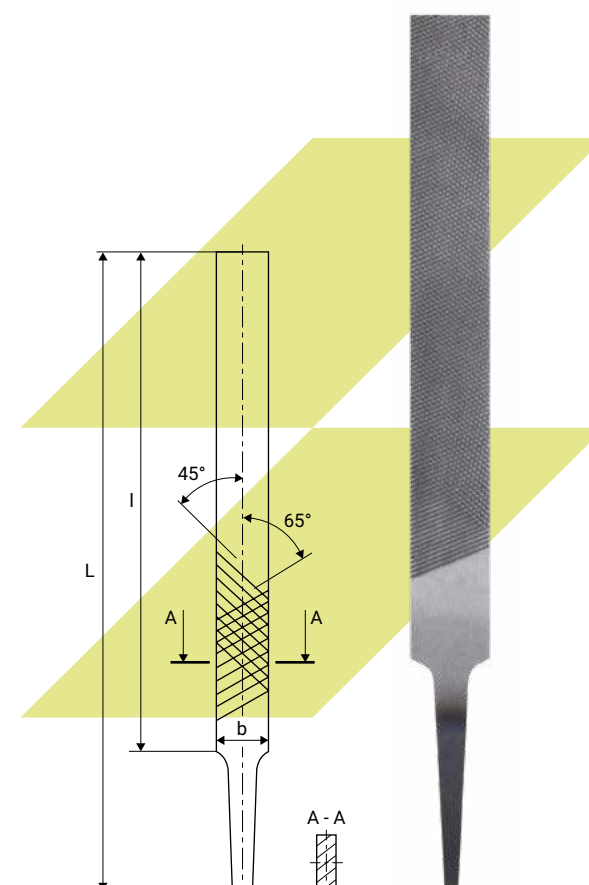

Напильники полукруглые

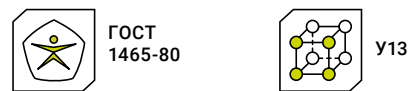

Артикул	Обозначение по ГОСТ	Номер насечки	b, мм	l, мм	L, мм
1220455	2822-0117	1	16	150	200
1220456	2822-0119	2	16	150	200
1220457	2822-0121	3	16	150	200
1220458	2822-0125	1	20	200	255
1220459	2822-0127	2	20	200	255
1220460	2822-0129	3	20	200	255
1220461	2822-0133	1	25	250	310
1220462	2822-0135	2	25	250	310
1220463	2822-0137	3	25	250	310
1220464	2822-0141	1	30	300	370
1220465	2822-0143	2	30	300	370
1220466	2822-0145	3	30	300	370
1220467	2822-0151	1	35	350	430
1220468	2822-0153	2	35	350	430
1220469	2822-0155	3	35	350	430
1220470	2822-0159	1	40	400	490
1220471	2822-0161	2	40	400	490
1220472	2822-0163	3	40	400	490

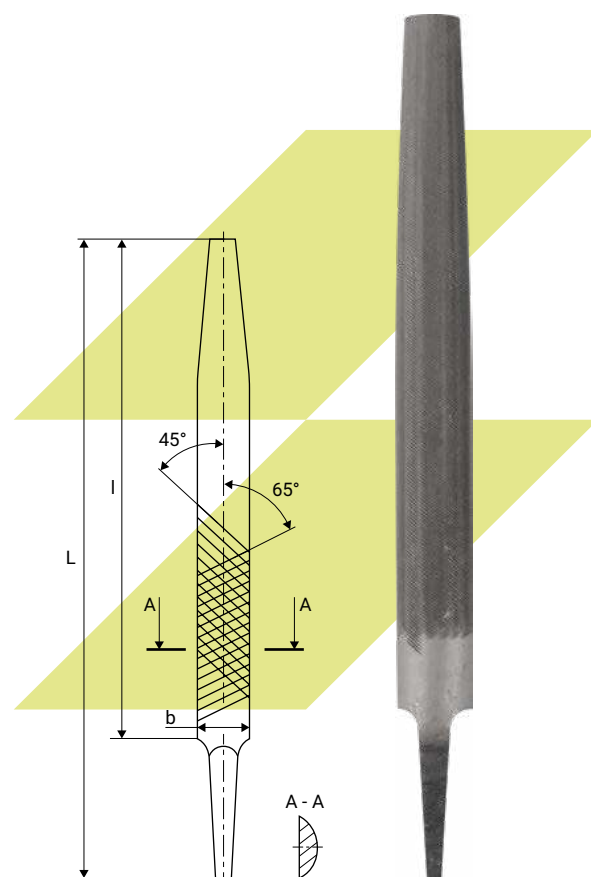

Напильники ромбические

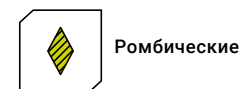
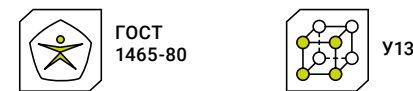

Артикул	Обозначение по ГОСТ	Номер насечки	b, мм	l, мм	L, мм
1220452	2821-0101	2	12,5	100	140
1220453	2821-0109	2	19	150	200
1220454	2821-0113	2	25	200	255
1255445	2821-0114	3	25	200	255
1255446	2821-0115	4	25	200	255
1331305	2821-0117	2	32	250	310
1331306	2821-0118	3	32	250	310

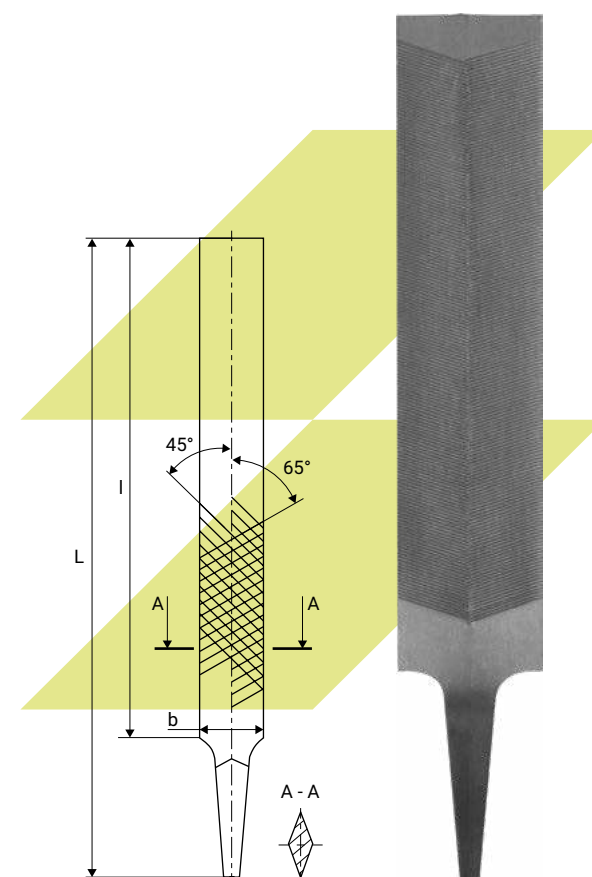

Напильники трехгранные



ГОСТ
1465-80

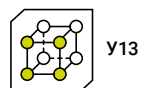

У13



Трехгранный

Артикул	Обозначение по ГОСТ	Номер насечки	b, мм	l, мм	L, мм
1220473	2821-0051	1	8,0	100	140
1220474	2821-0052	2	8,0	100	140
1220475	2821-0053	3	8,0	100	140
1220476	2821-0056	1	10,0	125	170
1220477	2821-0057	2	10,0	125	170
1220478	2821-0058	3	10,0	125	170
1220479	2821-0061	1	11,0	150	200
1220480	2821-0062	2	11,0	150	200
1220481	2821-0063	3	11,0	150	200
1220482	2821-0066	1	15,0	200	255
1220483	2821-0067	2	15,0	200	255
1220484	2821-0068	3	15,0	200	255
1220485	2821-0071	1	17,5	250	310
1220486	2821-0072	2	17,5	250	310
1220487	2821-0073	3	17,5	250	310
1220488	2821-0076	1	20,0	300	370
1220489	2821-0077	2	20,0	300	370
1220490	2821-0078	3	20,0	300	370
0103851	2821-0079	4	20,0	300	370
1220491	2821-0082	1	24,0	350	430
1220492	2821-0083	2	24,0	350	430
1220493	2821-0084	3	24,0	350	430
1220494	2821-0086	1	27,0	400	490
1220495	2821-0087	2	27,0	400	490
1220496	2821-0088	3	27,0	400	490

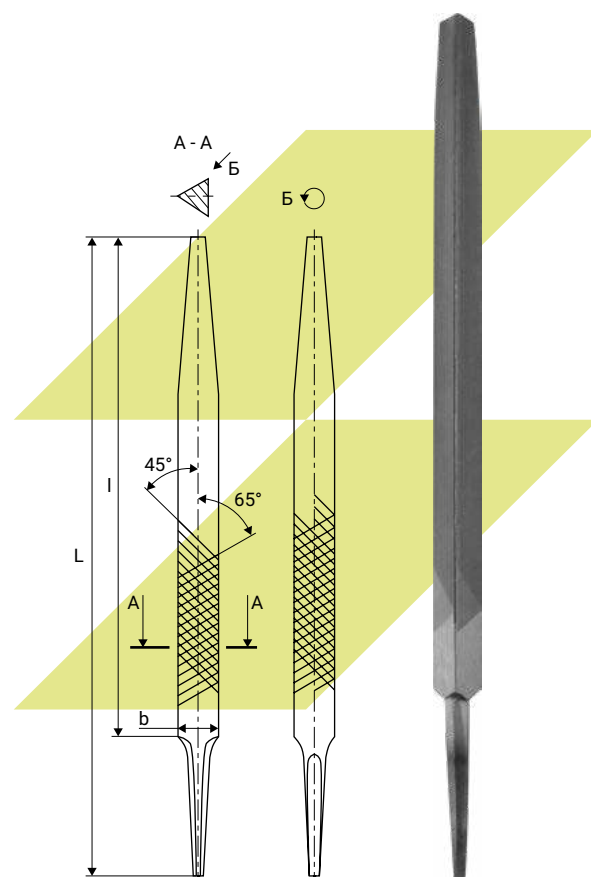

Надфили квадратные



ГОСТ
1513-77

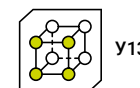

У13



Квадратный

Артикул	Обозначение по ГОСТ	Номер насечки	b, мм	l, мм	L, мм
1240407	2827-0062	2	1,8	50	100
1240408	2827-0063	4	1,8	50	100
1240409	2827-0067	1	2,0	60	120
1240410	2827-0068	3	2,0	60	120
1102489	-	00	-	80	140
1228532	2827-0073	0	2,8	80	160
1228533	2827-0072	00	2,8	80	160
1425494	-	1	2,8	80	160
1228534	2827-0074	2	2,8	80	160
1228535	-	3	2,8	80	160
1255428	2827-0075	4	2,8	80	160

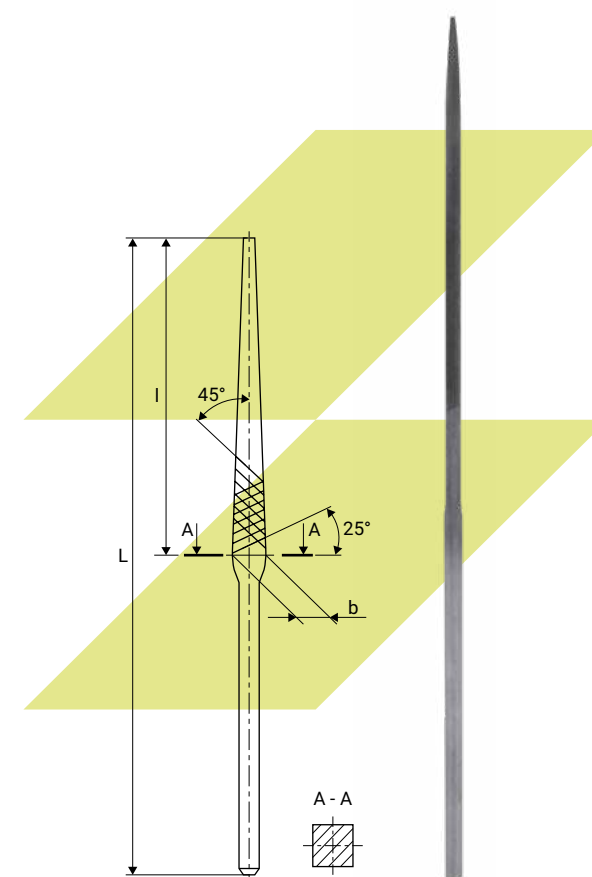

Надфили круглые



ГОСТ
1513-77



У13



Круглый

Артикул	Обозначение по ГОСТ	Номер насечки	d, мм	l, мм	L, мм
1240411	2828-0042	2	2,0	50	100
1240412	2828-0043	4	2,0	50	100
1240413	2828-0047	1	2,5	60	120
1240414	2828-0048	3	2,5	60	120
1228536	2828-0053	0	3,5	80	160
1228537	2828-0052	00	3,5	80	160
1425495	-	1	3,5	80	160
1228538	2828-0054	2	3,5	80	160
1255431	2828-0055	4	3,5	80	160

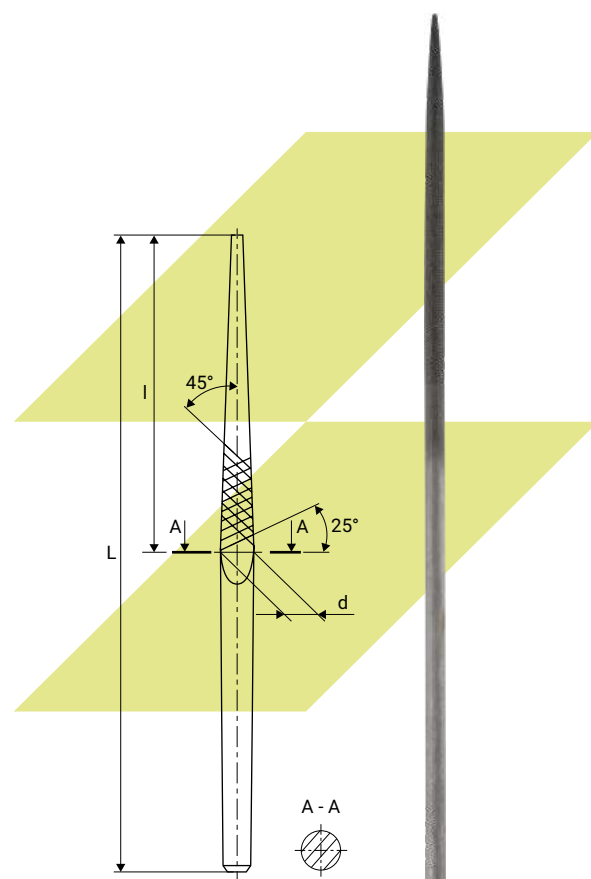

Надфили полукруглые



ГОСТ
1513-77

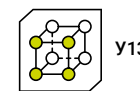

У13



Полукруглый

Артикул	Обозначение по ГОСТ	Номер насечки	b, мм	l, мм	L, мм
1240427	2828-0062	2	3	50	100
1240428	2828-0063	4	3	50	100
1240429	2828-0067	1	4	60	120
1240430	2828-0068	3	4	60	120
1228544	2828-0073	0	5	80	160
1228545	2828-0072	00	5	80	160
1228546	2828-0074	2	5	80	160
1255440	2828-0075	4	5	80	160

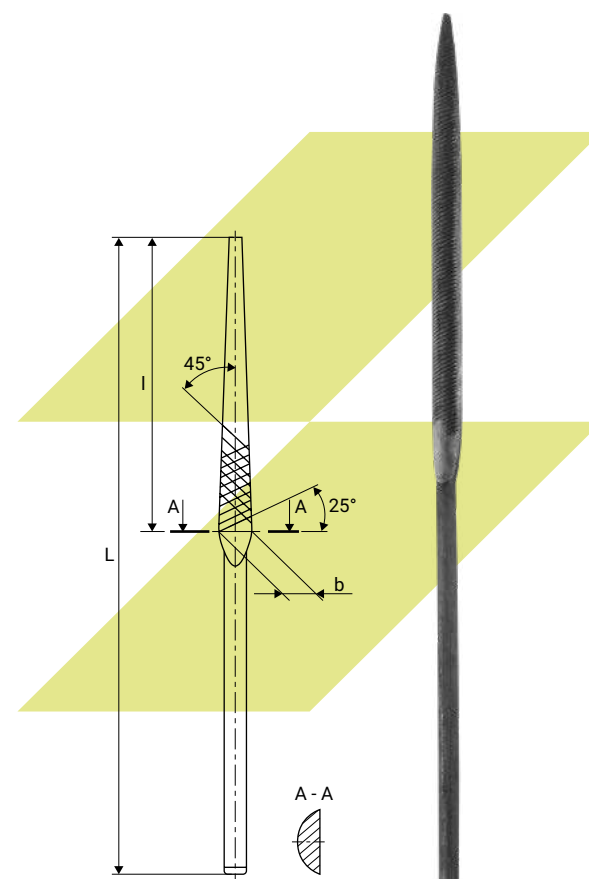

Надфили овалыные



Артикул	Обозначение по ГОСТ	Номер насечки	b, мм	l, мм	L, мм
1240415	2828-0112	2	3,0	50	100
1240416	2828-0113	4	3,0	50	100
1240417	2828-0117	1	4,0	60	120
1240418	2828-0118	3	4,0	60	120
1228539	2828-0123	0	5,5	80	160
1228540	2828-0122	00	5,5	80	160
1228541	-	1	5,5	80	160
1228542	2828-0124	2	5,5	80	160
1228543	-	3	5,5	80	160
1253803	2828-0125	4	5,5	80	160

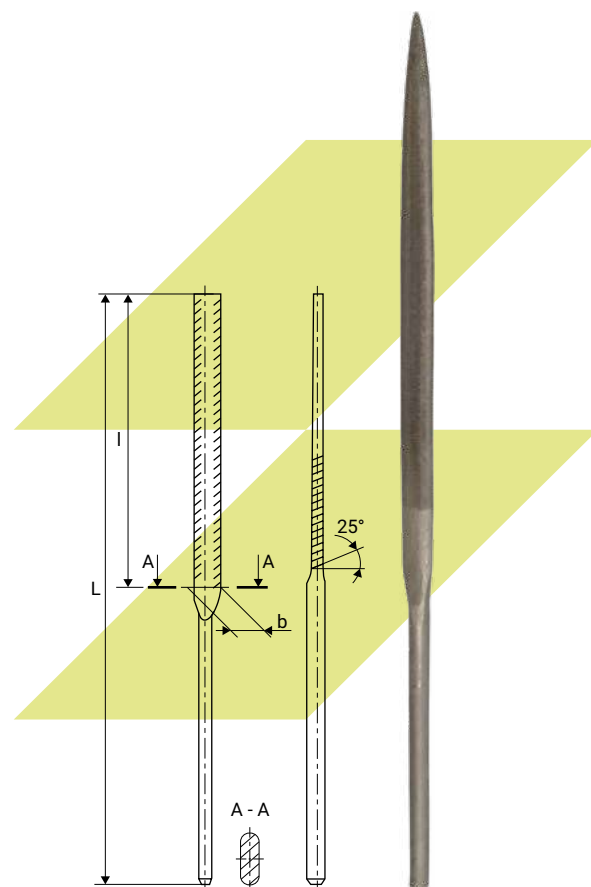

Надфили плоские остроносые

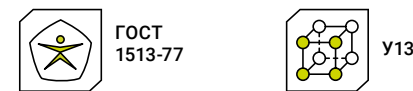

Артикул	Обозначение по ГОСТ	Номер насечки	b, мм	l, мм	L, мм
1240419	2826-0042	2	3,0	50	100
1240420	2826-0043	4	3,0	50	100
1240421	2826-0047	1	4,0	60	120
1240422	2826-0048	3	4,0	60	120
1228653	2826-0053	0	5,5	80	160
1228654	2826-0052	00	5,5	80	160
1228655	2826-0054	2	5,5	80	160
1255437	2826-0055	4	5,5	80	160

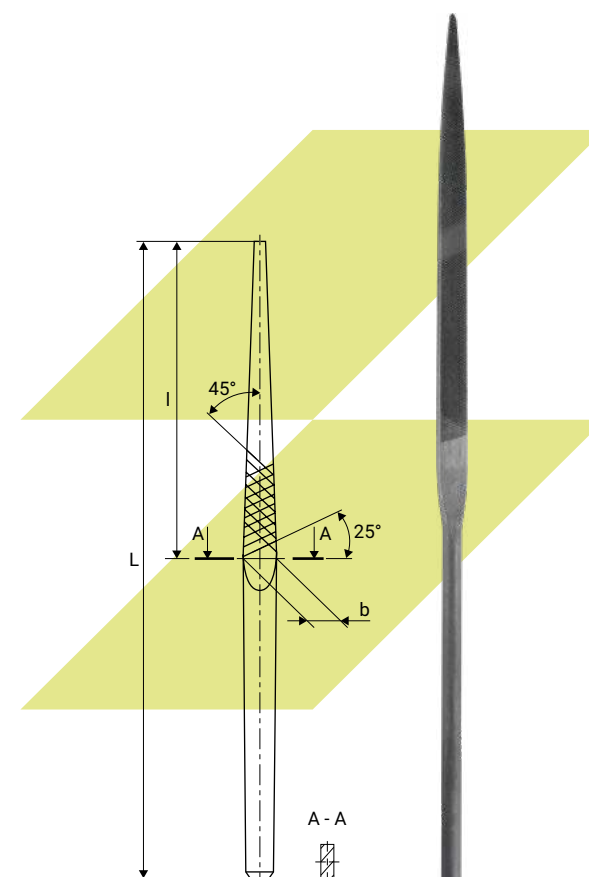

Надфили плоские тупоносые



ГОСТ
1513-77



У13



Плоский

Артикул	Обозначение по ГОСТ	Номер насечки	b, мм	l, мм	L, мм
1240423	2826-0022	2	3,0	50	100
1240424	2826-0023	4	3,0	50	100
1240425	2826-0027	1	4,0	60	120
1240426	2826-0028	3	4,0	60	120
1228656	2826-0033	0	5,5	80	160
1228657	2826-0032	00	5,5	80	160
1256726	-	1	5,5	80	160
1228658	2826-0034	2	5,5	80	160
1228659	-	3	5,5	80	160
1255438	2826-0035	4	5,5	80	160

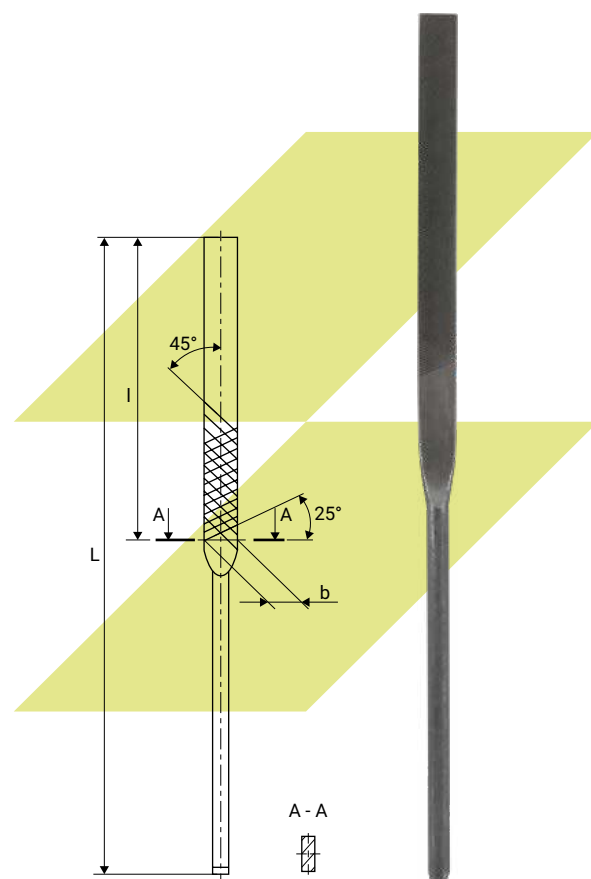

Надфили ромбические



ГОСТ
1513-77

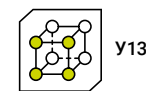

У13



Ромбический

Артикул	Обозначение по ГОСТ	Номер насечки	b, мм	l, мм	L, мм
1240431	2827-0122	2	4,0	50	100
1240432	2827-0123	4	4,0	50	100
1240433	2827-0127	1	4,5	60	120
1257892	-	2	4,5	60	120
1240434	2827-0128	3	4,5	60	120
1337822	2827-0133	0	6,0	80	160
1228547	2827-0132	00	6,0	80	160
1425496*	-	00	6,0	80	160
1240194	2827-0134	2	6,0	80	160
1257893	2827-0135	4	6,0	80	160

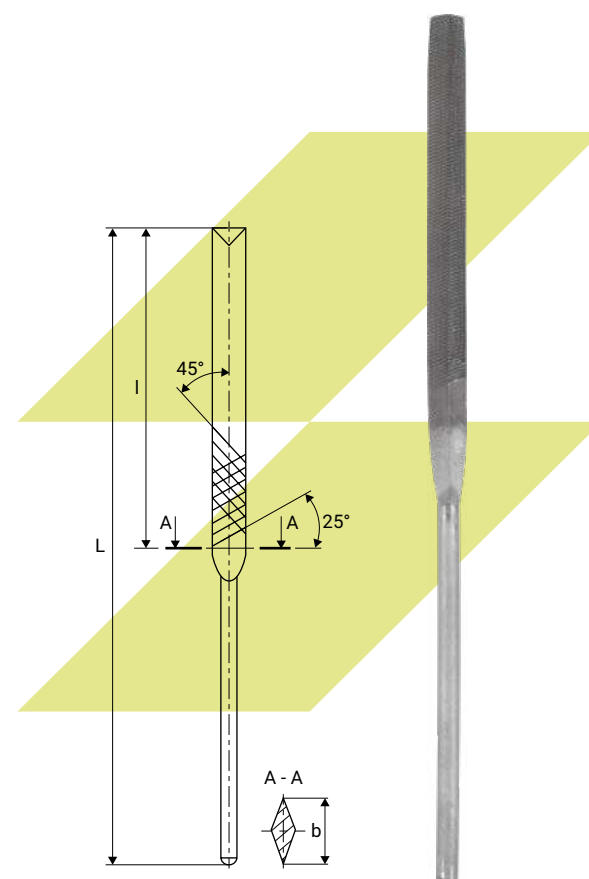

Надфили трехгранные



ГОСТ
1513-77

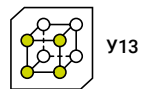

У13



Трехгранный

Артикул		Обозначение по ГОСТ	Номер насечки	b, мм	l, мм	L, мм
1240435	●	2827-0082	2	2,6	50	100
1240436	●	2827-0083	4	2,6	50	100
1289537	●	2827-0086	0	3,0	60	120
1240437	●	2827-0087	1	3,0	60	120
1240438	●	2827-0088	3	3,0	60 <td 120	
1228548	●	2827-0093	0	3,5	80	160
1228549	●	2827-0092	00	3,5	80	160
1228550	●	-	1	3,5	80	160
1228551	●	2827-0094	2	3,5	80	160
1255443	●	2827-0095	4	3,5	80	160

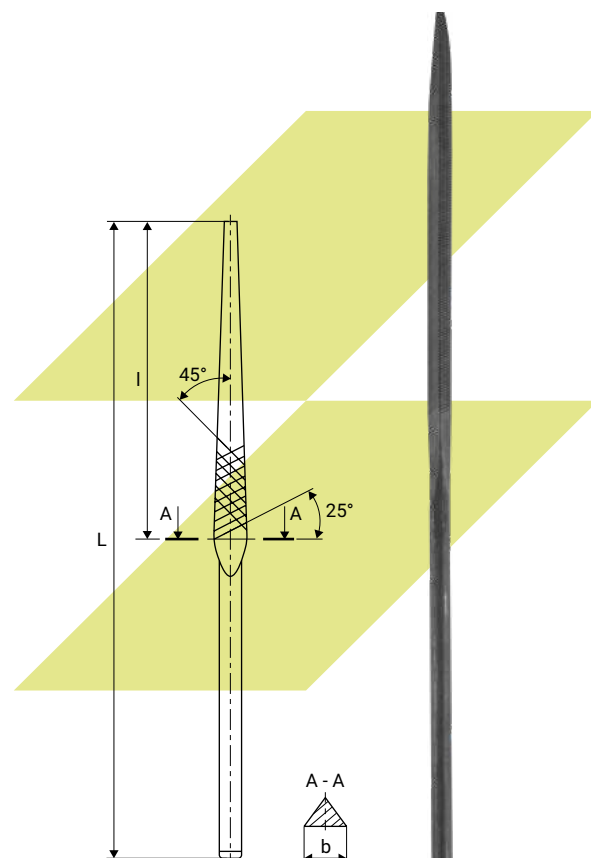

Надфили трехгранные односторонние



ГОСТ
1513-77

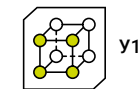

У13



Трехгранный односторонний

Артикул		Обозначение по ГОСТ	Номер насечки	b, мм	l, мм	L, мм
1240439	●	2827-0102	2	4,0	50	100
1240440	●	2827-0103	4	4,0	50	100
1240441	●	2827-0107	1	4,5	60	120
1240442	●	2827-0108	3	4,5	60	120
1240443	●	2827-0112	00	6,0	80	160
1240444	●	2827-0114	2	6,0	80	160

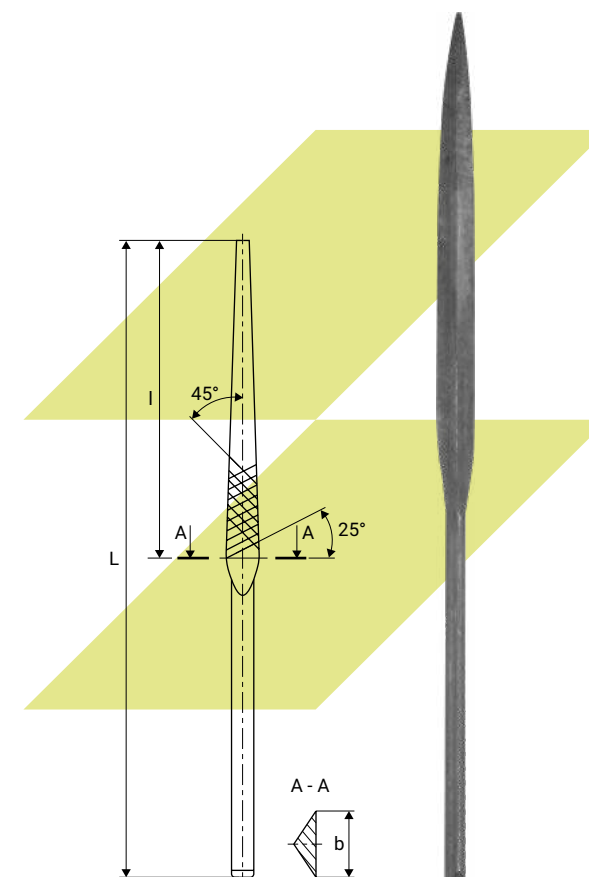

Надфили ножовочные



ГОСТ
1513-77



У13



Ножовочный

Артикул	Обозначение по ГОСТ	Номер насечки	b, мм	l, мм	L, мм
1265228	2828-0087	1	4,0	60	120
1265229	2828-0088	3	4,0	60	120
1265230	2828-0092	00	5,5	80	160
1265231	2828-0094	2	5,5	80	160

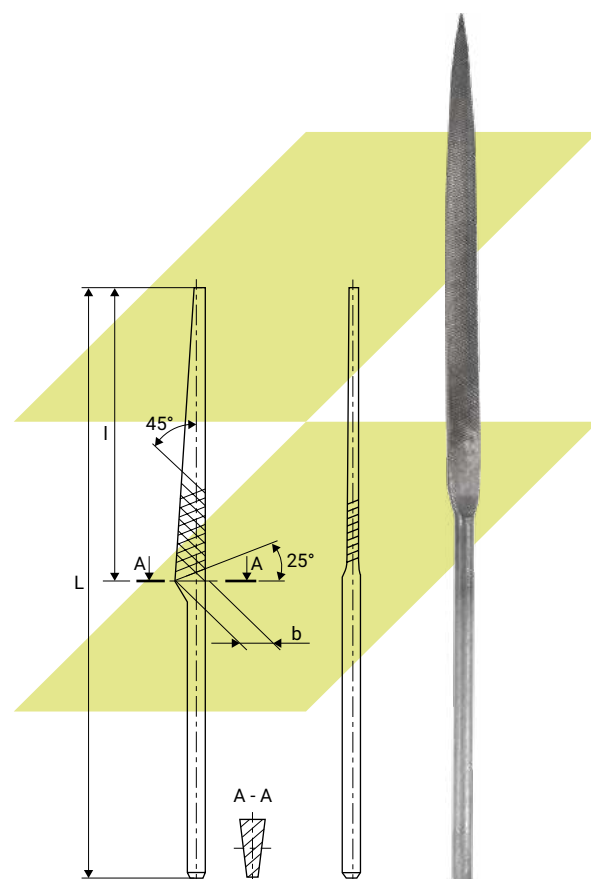

Плоскогубцы



Декоративные

Артикул	L, мм
1326565	125
1228660	160
1228661	180
1228662	200

Производитель: ООО «АРЕФИНО ИНСТРУМЕНТ»

Артикул	L, мм
C66	160
C161	180

Производитель: ООО «НИЗ»

Артикул	L, мм
1376338	200

Производитель: ООО «КВТ»

Артикул	L, мм
78240	120
78244	125
78242*	125
77420	180
77421	200

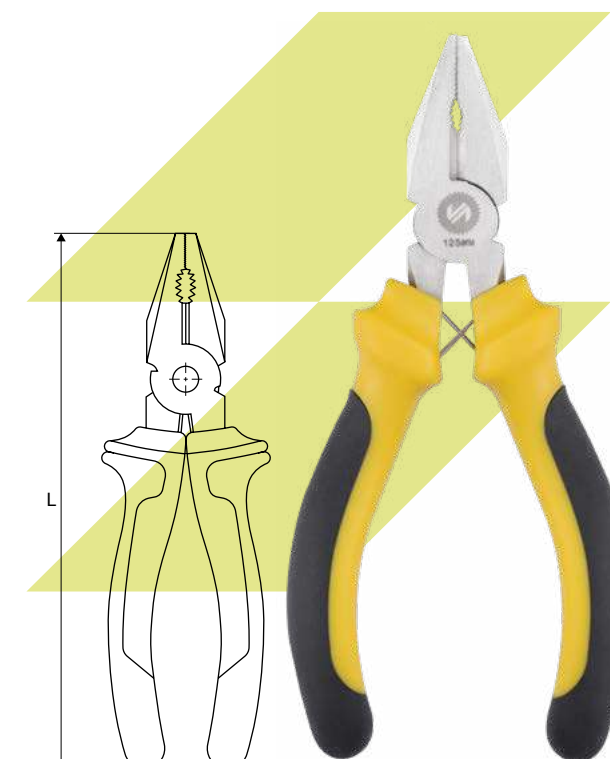

*С удлиненными губками

Плоскогубцы радиотехнические



Декоративные

Артикул		L, мм	Рукоятки
114052	●	100	декоративные
114053	●	125	декоративные
114054	●	140	декоративные

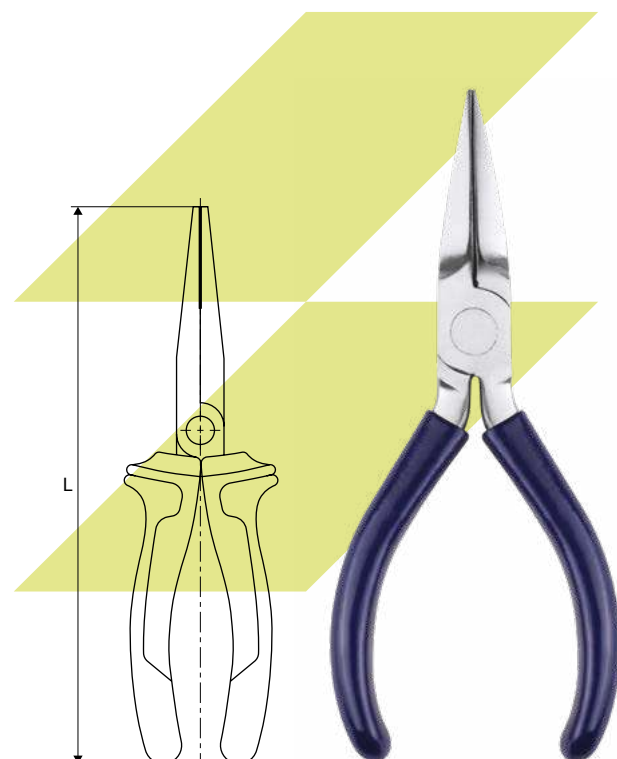

Плоскогубцы регулируемые



Декоративные

Производитель: ООО «НИЗ»

Артикул		L, мм	Рукоятки
1181961	●	250	декоративные

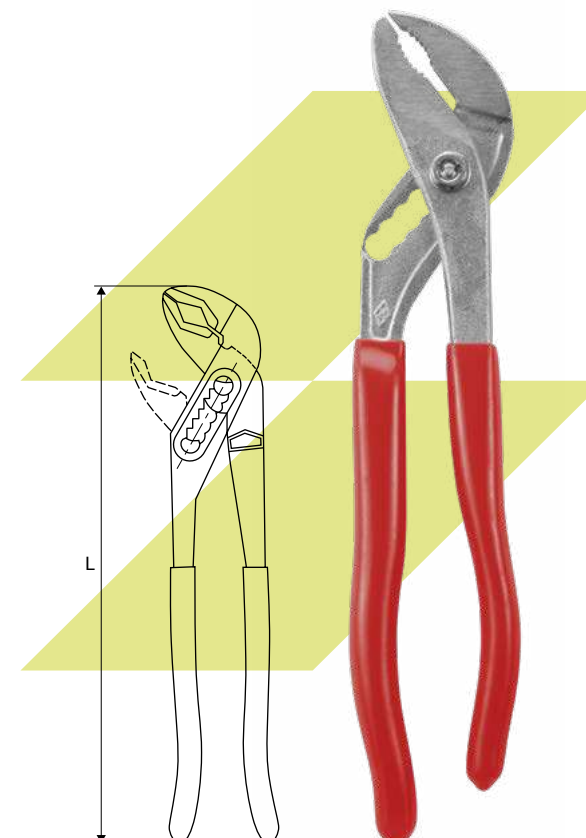

Плоскогубцы диэлектрические



Изолированные
1000 В

Артикул		L, мм
1331201	●	160

Производитель: ООО «НИЗ»

Артикул		L, мм
1323651	●	200

Производитель: ООО «КВТ»

Артикул		L, мм
70355	●	160
70356	●	200
61436*	●	250

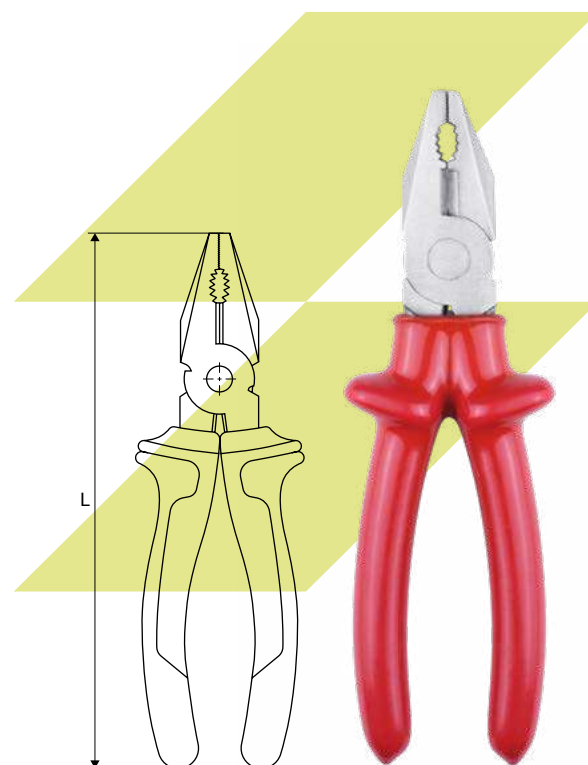

*Переставные

Кусачки торцевые



Декоративные

Артикул		L, мм	Рукоятки
1479742	●	110	декоративные
1228663	●	160	декоративные

Производитель: ООО «НИЗ»

Артикул		L, мм	Рукоятки
1477828	●	200	декоративные

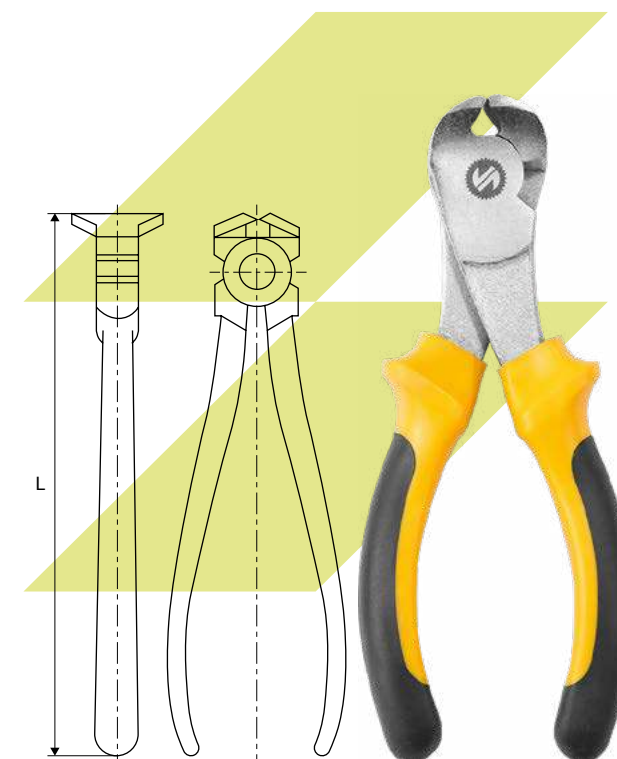

Кусачки торцевые диэлектрические



Изолированные
1000 В

Производитель: ООО «НИЗ»

Артикул		L, мм
1349137	●	200

Производитель: ООО «КВТ»

Артикул		L, мм
77429	●	160

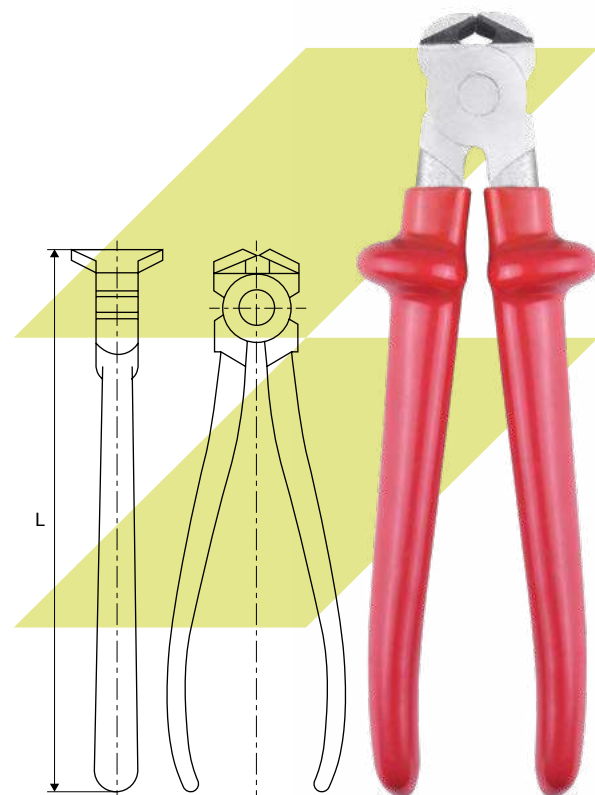

Кусачки боковые

Артикул		L, мм	Рукоятки
1228664	●	160	декоративные
1238336	●	180	декоративные
102510	●	115	без декор. рукояток

Производитель: ООО «НИЗ»

Артикул		L, мм	Рукоятки
1379521	●	160	декоративные
1102502	●	200	декоративные

Производитель: ООО «КВТ»

Артикул		L, мм	Рукоятки
78241	●	115	декоративные
55938	●	125	декоративные
77427	●	160	декоративные

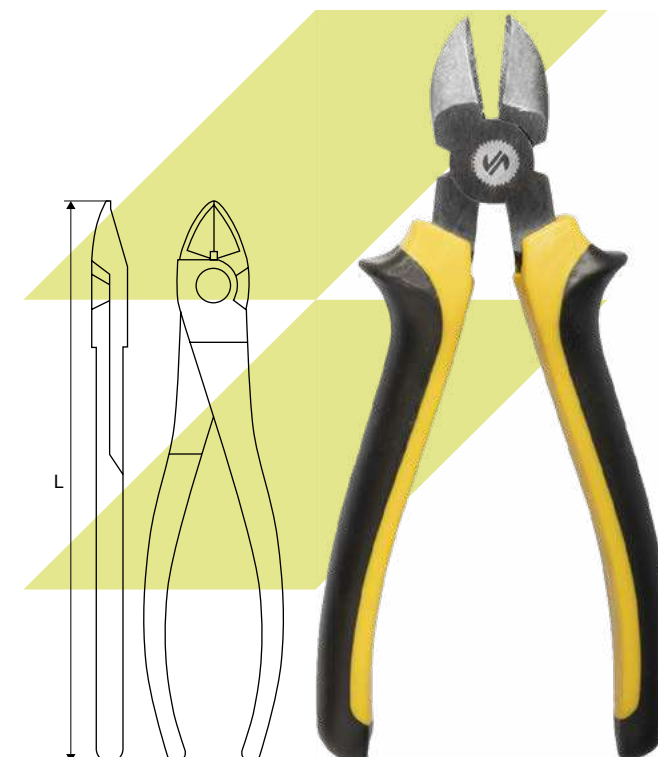

Кусачки боковые диэлектрические



Изолированные
1000 В

Производитель: ООО «НИЗ»

Артикул		L, мм
113212	●	160
1236329	●	200

Производитель: ООО «КВТ»

Артикул		L, мм
70358	●	160
70359	●	180

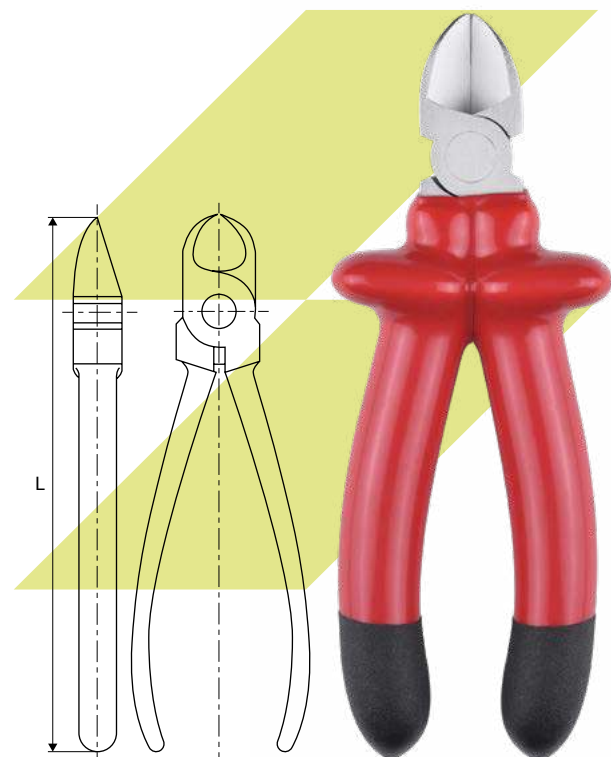

Леворежущие ножницы по металлу

Производитель: ООО «АРЕФИНО ИНСТРУМЕНТ»

Артикул		L, мм
C235	●	250
C195	●	250
C60	●	250
C9	●	250
C61	●	320
C10	●	320

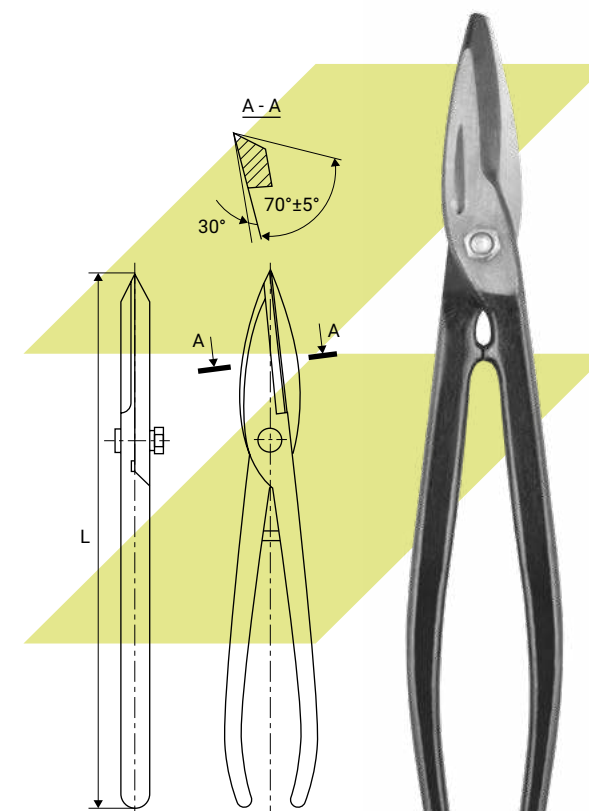

Плотна ручные односторонние биметаллические



P6M5

Артикул		L, мм	P	b, мм	h, мм
1337606	●	300	32	0,8	12,5
1337605	●	300	24	1,0	12,5
1337604	●	300	18	1,4	12,5

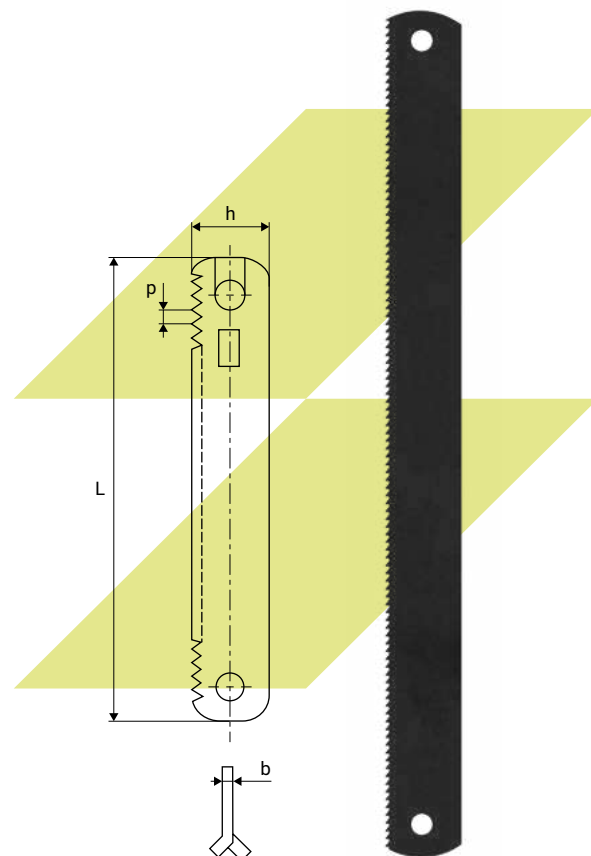

Плотна ручные односторонние

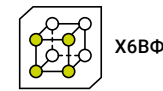

X6BФ

Артикул		L, мм	P	b, мм	h, мм
114069	●	300	24	0,6	12,5

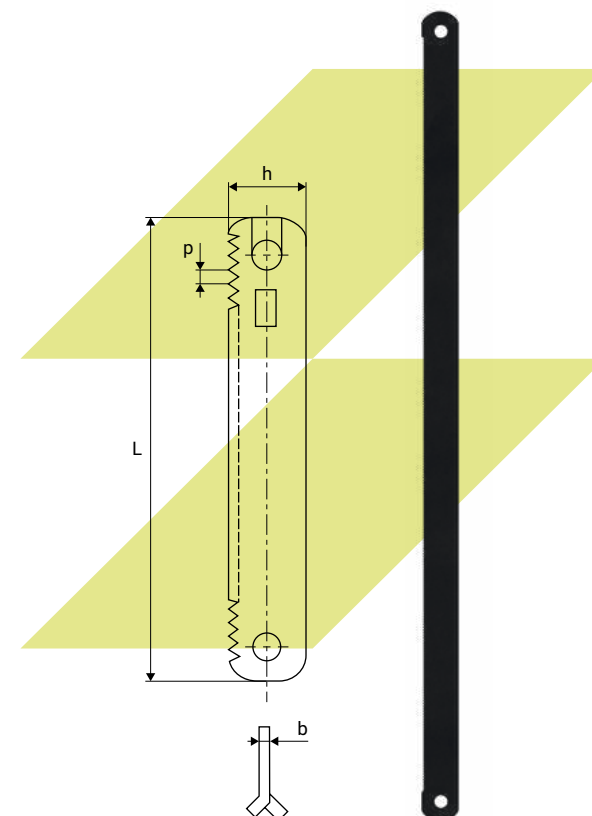

Молотки



Производитель: ООО «АРЕФИНО ИНСТРУМЕНТ»

Артикул		Вес бойка, кг
C281	●	0,2
C601	●	0,3
C200	●	0,4
C124	●	0,5
C199	●	0,5
C173	●	0,6
C570	●	0,8
C572	●	1,0

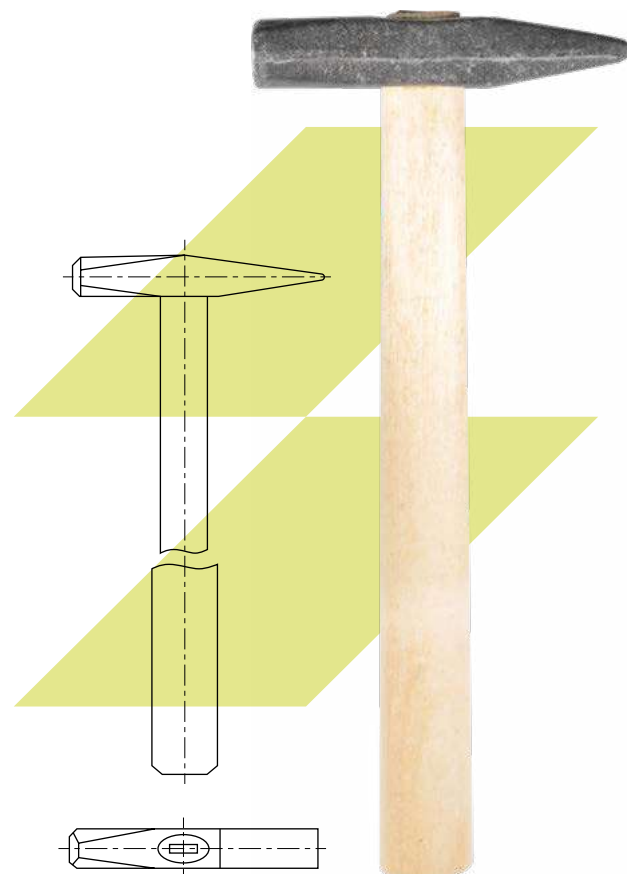

Молотки



Производитель: ООО «КЗСМИ»

Артикул		Обозначение по ГОСТ	Вес бойка, кг	L, мм
1417495	●	7850-0115	0,1	250
1416421	●	7850-0122	1,0	400

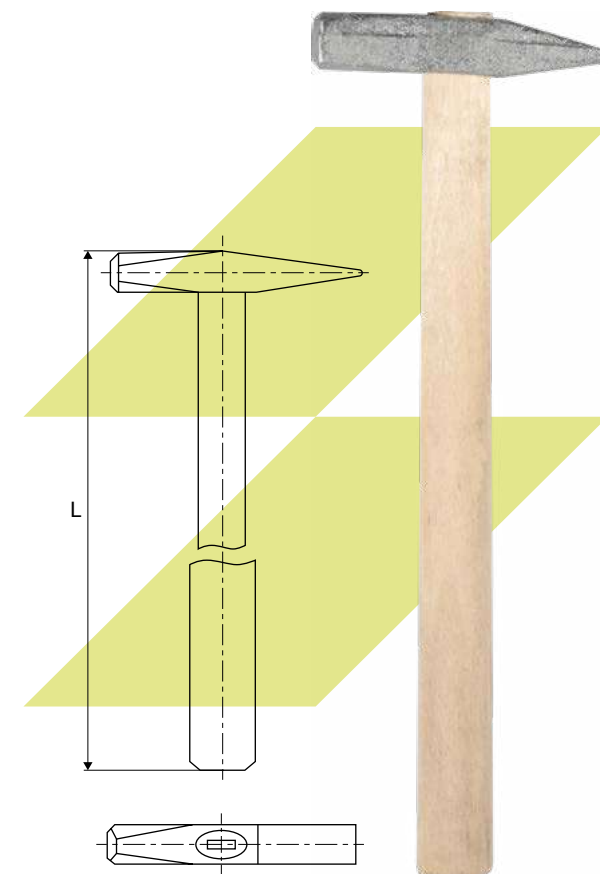

Молотки



ГОСТ
2310-77



Квадратный

Производитель: ООО «НИЗ»

Артикул	Обозначение по ГОСТ	Вес бойка, кг	L, мм
1751691	7850-0116	0,2	250
1751692	7850-0117	0,4	320
1729338	7850-0118	0,5	320
1751693	7850-0119	0,6	360
1751694	7850-0121	0,8	360

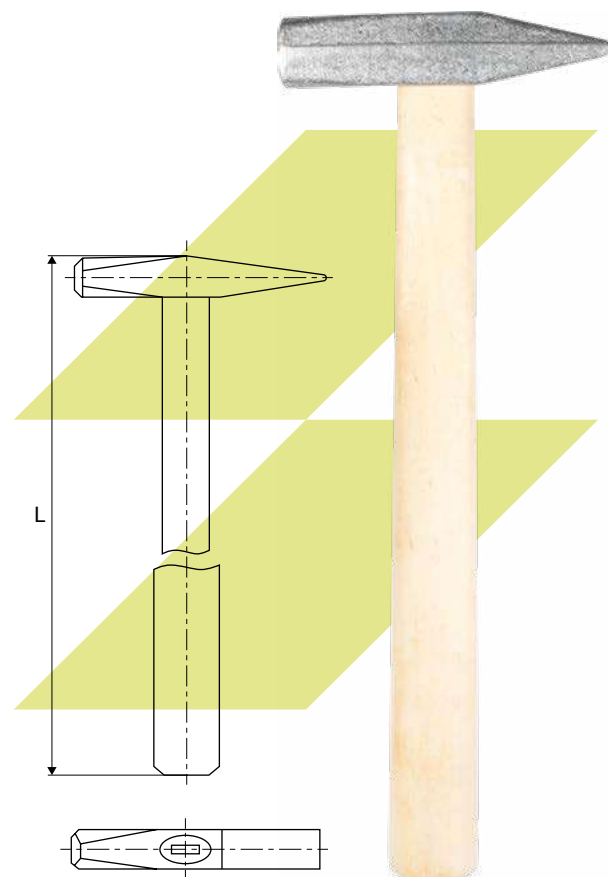

Молотки



Круглый

Производитель: ООО «АРЕФИНО ИНСТРУМЕНТ»

Артикул	Вес бойка, кг
C97	0,4
C577	0,5
C580	0,6
C544	0,8

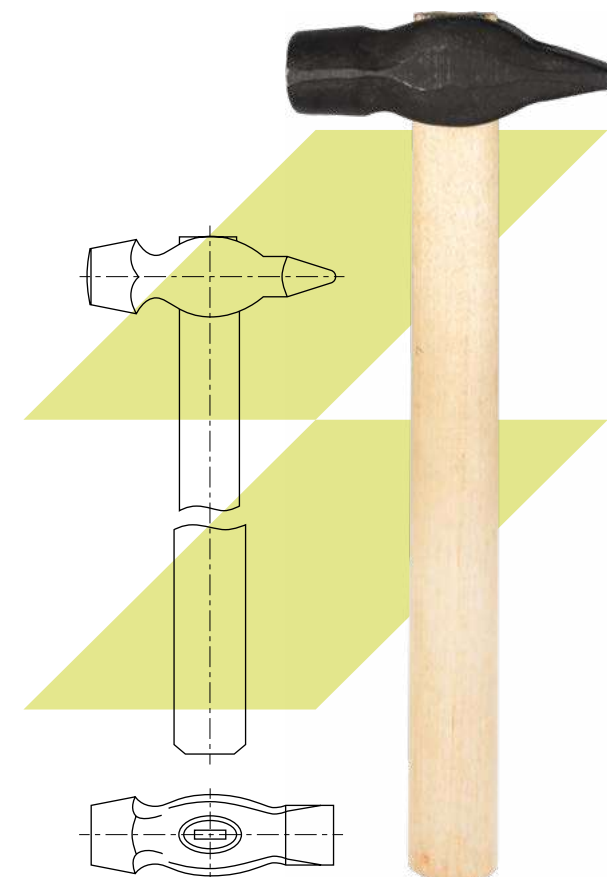

Молотки



ГОСТ
2310-77



Круглый

Производитель: ООО «КЗСМИ»

Артикул		Обозначение по ГОСТ	Вес бойка, кг	L, мм
1417327	●	7850-0101	0,2	250
1479782	●	7850-0102	0,4	320
1417328	●	7850-0103	0,5	320
1584521	●	7850-0104	0,6	360
1584523	●	7850-0105	0,8	360
1177370	●	7850-0106	1,0	400

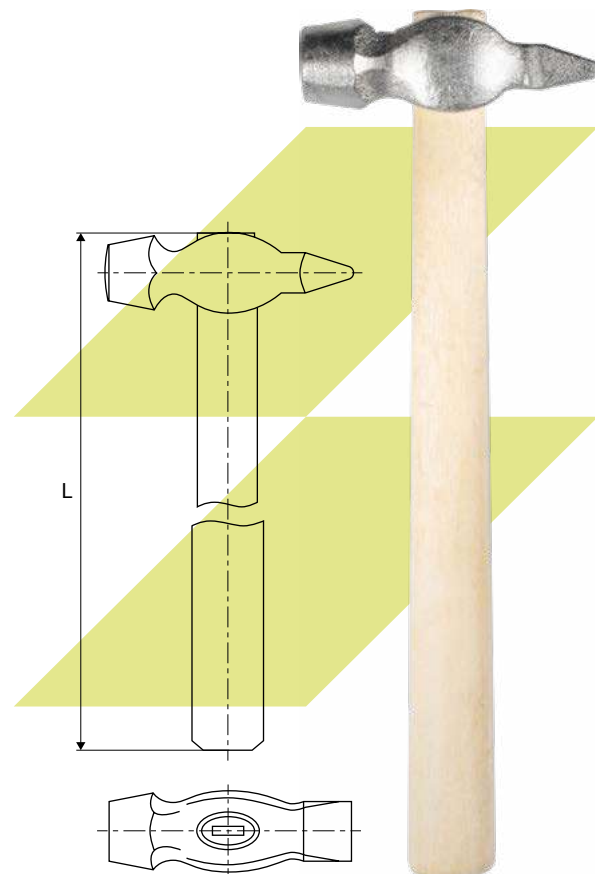

Молотки искробезопасные



Круглый

Производитель: ООО «КЗСМИ»

Артикул		Вес бойка, кг	L, мм
1584519	●	0,2	250
1584520	●	0,4	320

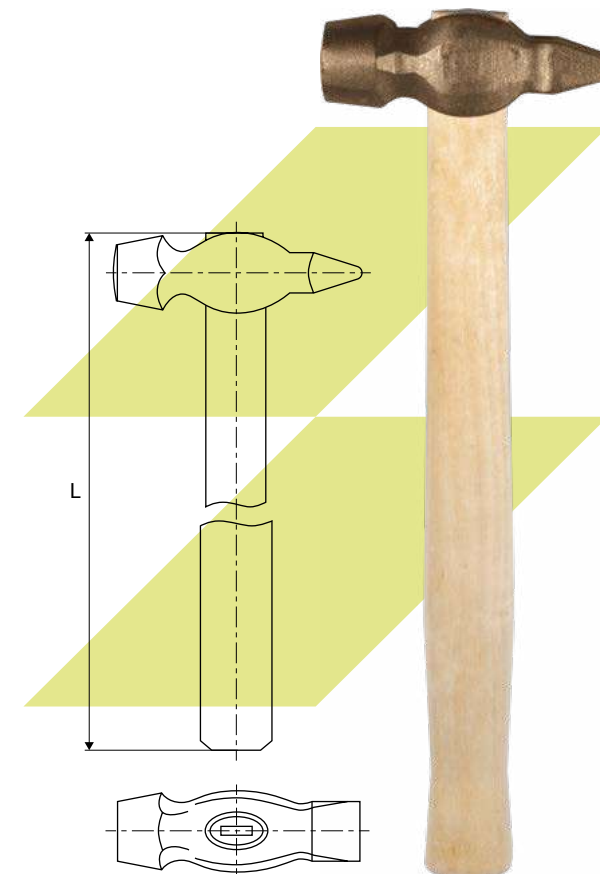

Кувалды тупоносые

Производитель: ООО «АРЕФИНО ИНСТРУМЕНТ»

Артикул		Вес бойка, кг	h, мм	L, мм
C268	●	1,0	40	90
C543	●	1,5	45	105
C270	●	2,0	50	128
C271	●	3,0	58	142
C272	●	4,0	62	152
C273	●	5,0	68	166
C274	●	6,0	72	176
C275	●	7,0	72	180
C276	●	8,0	80	186
C541	●	9,0	82	192
C542	●	10,0	85	200

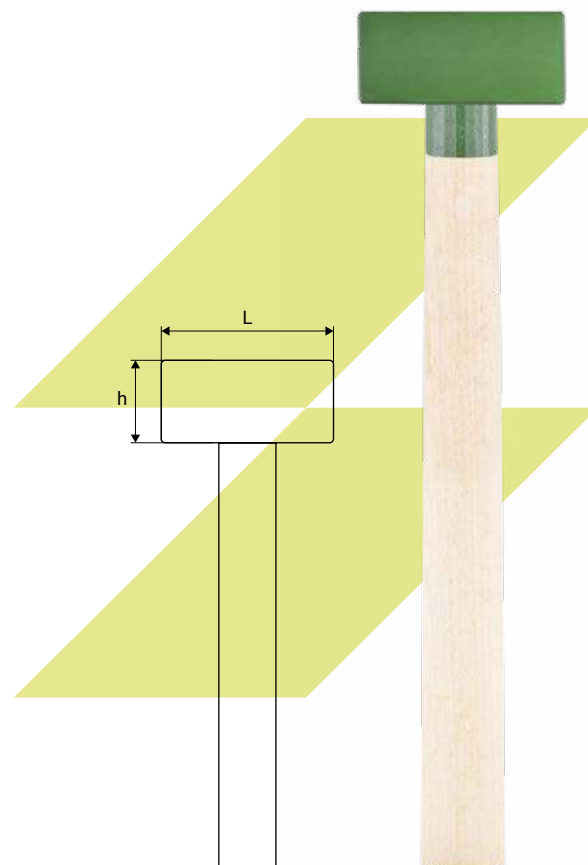

Буры с хвостовиком SDSplus

Артикул		D, мм	I, мм	L, мм
1477502	●	5,0	60	110
1477503	●	5,0	110	160
1477504	●	6,0	60	110
1477505	●	6,0	110	160
1477506	●	6,0	160	210
1477507	●	6,0	210	260
1477508	●	8,0	60	110
1477509	●	8,0	110	160
1477510	●	8,0	160	210
1477511	●	8,0	210	260
1477512	●	8,0	260	310
1477513	●	10,0	60	110
1477514	●	10,0	110	160
1477515	●	10,0	160	210
1477516	●	10,0	210	260
1477517	●	10,0	260	310
1477518	●	12,0	160	210
1477519	●	12,0	210	260
1477520	●	12,0	260	310
1477521	●	12,0	360	410
1477522	●	14,0	160	210
1477523	●	14,0	360	410
1477524	●	14,0	560	610
1477525	●	16,0	410	460
1477526	●	16,0	750	800
1477527	●	18,0	410	460
1477528	●	18,0	560	610
1477529	●	18,0	750	800
1477530	●	18,0	950	1000
1477531	●	20,0	560	610
1477532	●	20,0	750	800
1477533	●	20,0	950	1000
1477534	●	22,0	750	800
1477535	●	25,0	950	1000

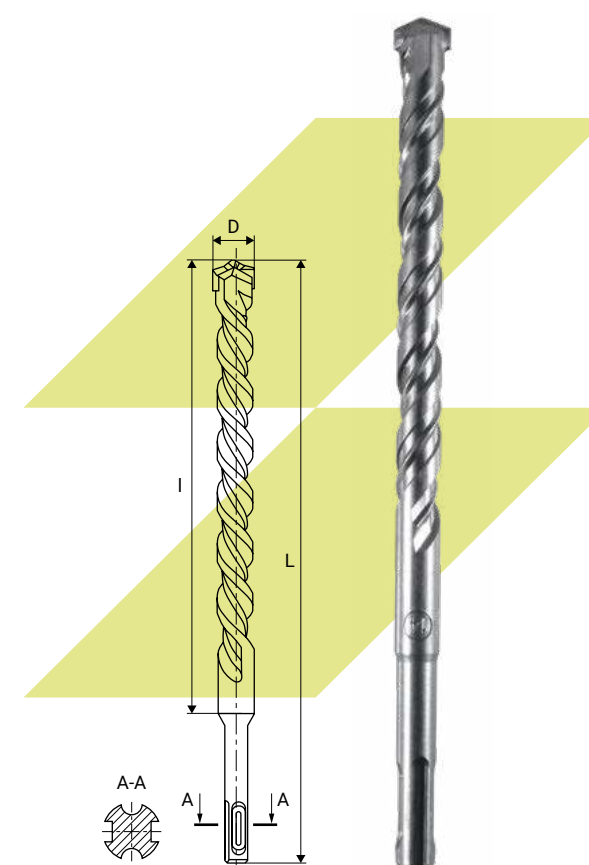

Клейма цифровые из твердого сплава

123 Цифровые

Твердый сплав

Артикул		Высота шрифта, мм
102066	●	2
102068	●	3
1108724	●	4
102071	●	5
102073	●	6
118925	●	8
1108727	●	10
1108728	●	12



Клейма цифровые

123 Цифровые

Сталь

HRC 45-48

Артикул		Высота шрифта, мм
1583032	●	2
1583033	●	3
1583034	●	4
1583035	●	5
1583036	●	6
1583037	●	8
1583038	●	10
1583039	●	12



Клейма цифровые



Цифровые



Сталь

Производитель: GRAVUREM

Артикул		Высота шрифта, мм
1292756	●	1
1417078	●	2
1181283	●	3
1175661	●	4
1150257	●	5
1108515	●	6
1227143	●	8
1252641	●	10
1108516	●	12



Клейма цифровые



Цифровые



Сталь

Производитель: PRYOR

Артикул		Высота шрифта, мм
1128642	●	1,0
1131730	●	2,0
1418479	●	2,5
1131731	●	3,0
1111246	●	4,0
1131732	●	5,0
1111247	●	6,0
1111248	●	8,0
1111249	●	10,0
1128643	●	12,5



Клейма цифровые



Цифровые



Сталь



HRC 50-55

Артикул		Высота шрифта, мм
1583056	●	2
1583057	●	3
1583058	●	4
1583059	●	5
1583060	●	6
1583061	●	8
1583062	●	10
1583063	●	12



Клейма буквенные из твердого сплава



Кириллица



Буквенный



Твердый сплав

Артикул		Высота шрифта, мм
102057	●	2
102059	●	3
102061	●	4
102063	●	5
1108730	●	6
1108947	●	8
1108948	●	10
1108949	●	12



Клейма буквенные



Артикул		Высота шрифта, мм
1583040	●	2
1583041	●	3
1583042	●	4
1583043	●	5
1583044	●	6
1583045	●	8
1583046	●	10
1583047	●	12



Клейма буквенные

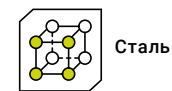
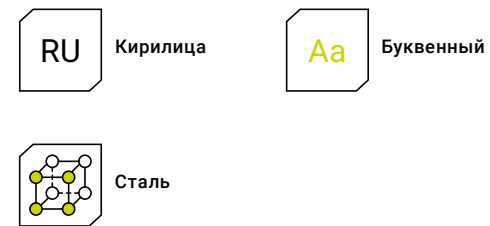

Производитель: GRAVUREM

Артикул		Высота шрифта, мм
1417077	●	2
1227144	●	3
1185480	●	4
1185753	●	5
1171706	●	6
1174762	●	8
1252640	●	10



Клейма буквенные

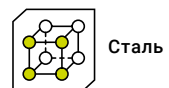

Производитель: PRYOR

Артикул		Высота шрифта, мм
1131721	●	2,0
1131722	●	3,0
1111242	●	4,0
1131723	●	5,0
1111243	●	6,0
1111244	●	8,0
1111245	●	10,0
1128641	●	12,5



Клейма буквенные

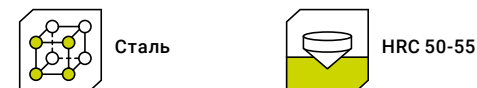

Артикул		Высота шрифта, мм
1583048	●	2
1583049	●	3
1583050	●	4
1583051	●	5
1583052	●	6
1583053	●	8
1583054	●	10
1583055	●	12



Клейма буквенные



Сталь

Производитель: PRYOR

Артикул		Высота шрифта, мм
1131724	●	1,0
1128638	●	2,0
1131725	●	3,0
1131726	●	4,0
1131727	●	5,0
1131728	●	6,0
1128639	●	8,0
1131729	●	10,0
1128640	●	12,5



Клейма буквенные

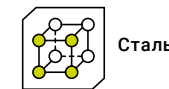

Сталь



HRC 45-48

Артикул		Высота шрифта, мм
1583024	●	2
1583025	●	3
1583026	●	4
1583027	●	5
1583028	●	6
1583029	●	8
1583030	●	10
1583031	●	12



Стамески плоские

Производитель: ООО «АРЕФИНО ИНСТРУМЕНТ»

Артикул		b, мм
C22	●	8
C36	●	12
C129	●	14
C37	●	16
C38	●	20
C290	●	28
C106	●	32

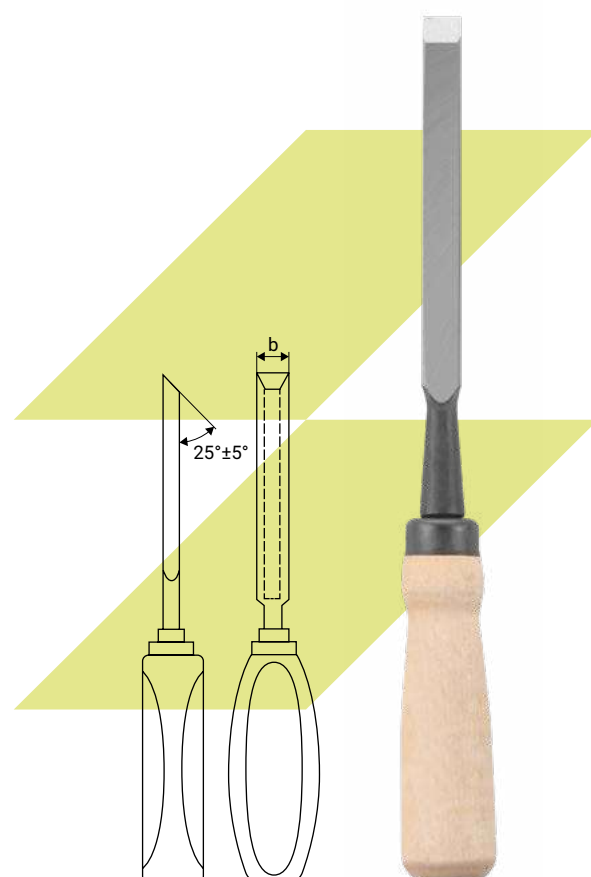

Стамески-долота

Производитель: ООО «АРЕФИНО ИНСТРУМЕНТ»

Артикул		b, мм
C333	●	10
C94	●	12
C91	●	16
C335	●	18
C93	●	20
C336	●	22
C223	●	25
C340	●	30

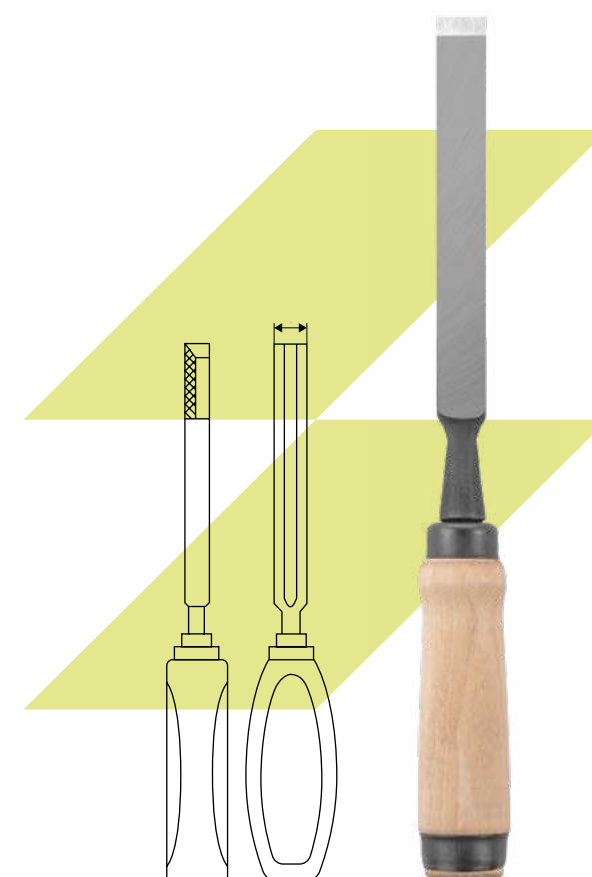

Электропаяльники нихромовые

МЭПСН с пластиковой рукояткой

Артикул	Мощность, Вт	Напряжение, В	Тип жала
1108009	18	6	стержень

ЭПЦН с пластиковой рукояткой

Артикул	Мощность, Вт	Напряжение, В	Тип жала	Ø стержня, мм
1419497	25	230	стержень	4
0118742	40	24	стержень	6
1289651	40	36	стержень	6
118743	40	42	стержень	6
1253270	65	36	стержень	6
1242030	65	42	стержень	6
118744	65	220	стержень	6
1289595	80	220	стержень	9
1612764	100	230	стержень	9



Электропаяльники нихромовые

ЭПСН с деревянной рукояткой

Артикул	Мощность, Вт	Напряжение, В	Тип жала	Ød, мм
119478	18	36	стержень	4
119483	25	12	стержень	4
119486	25	27	стержень	4
119484	40	12	стержень	6
1774316	65	230	стержень	6
1417785	200	230	стержень	20
1614629	150	24	топорик	-
1262876	200	24	топорик	-
1102543	200	36	топорик	-
1417786	200	230	топорик	-
1109792	250	36	топорик	-
1242034	250	220	топорик	-

ЭПЦН с деревянной рукояткой

Артикул	Мощность, Вт	Напряжение, В	Тип жала	Ød, мм
119479	25	36	стержень	4
1441479	25	230	стержень	4
119480	40	36	стержень	6
1240238	40	42	стержень	6
1612761	40	230	стержень	6
119485	65	24	стержень	6
119481	65	36	стержень	6
119482	65	42	стержень	6
1612762	65	230	стержень	6
1614642	80	36	стержень	9
1102375	80	220	стержень	9
1293123	100	36	стержень	9
1612763	100	230	стержень	9

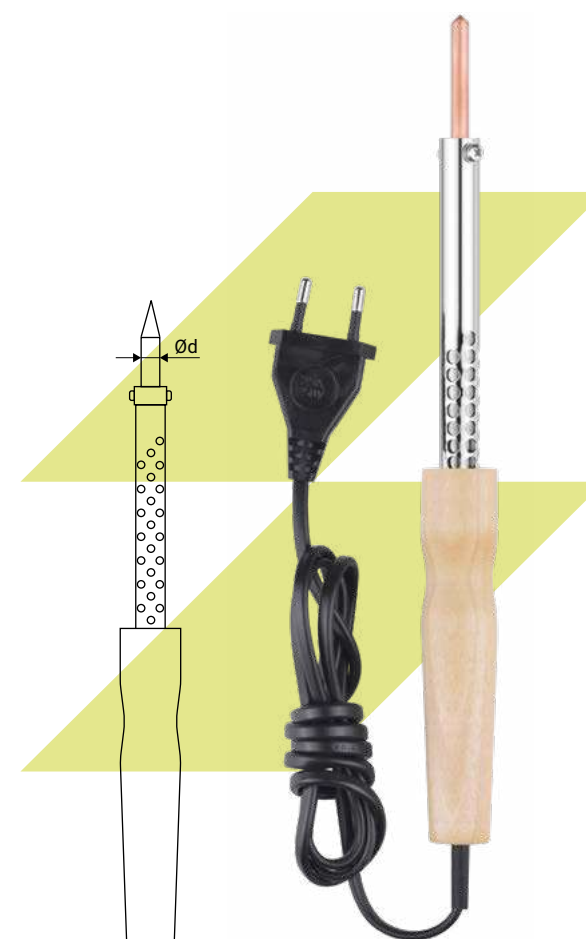



Абразивный инструмент

Инструмент на керамической связке	948
Инструмент на гибкой основе	963
Инструмент на бакелитовой основе	976
Инструмент на вулканитовой основе	978
Шлифовальный материал	980

Инструмент на керамической связке

Инструмент на керамической связке предназначен для шлифования деталей и конструкций из различных марок сталей, сварных швов, а также конструкционных, высоколегированных и углеродистых типов сталей. Применяется для выполнения слесарных работ, обработки кромок и плоскостей: удаления угловых сварных швов, удаления сварных швов на плоскости детали, снятия фаски детали с целью удаления заусенцев. Обладает высокой производительностью и внушительным рабочим ресурсом.



Инструмент на гибкой основе

Инструмент на гибкой основе предназначен для обработки как плоских, так и криволинейных поверхностей металла, дерева, окрашенных и лакированных поверхностей. Применяется для удаления старой краски. Зерно из оксида алюминия обеспечивает продолжительный срок службы. Тканевая основа равномерно изнашивается в процессе работы, открывая следующий слой абразива. Связующим элементом между зерном и подложкой служит синтетический каучук, который отличается высоким показателем гибкости и надежной фиксации абразива.



Инструмент на бакелитовой связке

Инструмент на бакелитовой связке применяется для реза по металлу, нержавеющей стали, алюминия, камню, пластику, плитке. Абразив удаляет ржавчину, заусенцы, окалину, применяется для зачистки сварных швов. Обладает высокой производительностью и внушительным рабочим ресурсом. Отличается твердостью и износостойкостью, что позволяет достаточно долго сохранять первоначальные режущие свойства.



Инструмент на вулканитовой связке

Инструмент на вулканитовой связке применяется для высокопроизводительной резки деталей и конструкций из различных марок стали. Идеально подходит для быстрого и эффективного удаления глубоких царапин на твердых и устойчивых к царапинам покрытиям и для работы на роторных полировальных машинках. Не перегревает поверхность. Отличается высокой скоростью реза и долгим сроком службы.



Шлифовальный материал

Шлифовальное зерно применяется для производства абразивных инструментов на всех связках для обработки заготовок из чугуна, титановых и титанотанталовых твердых сплавов, алюминия, меди, мрамора, гранита, цветных металлов, камня, стекла, кожи, дерева, пластмасс, резины. Используется для производства технической керамики, как наполнитель для огнеупоров, обработки кремниевых пластин при изготовлении полупроводников. Имеет высокую твердость и режущую способность.



Условные обозначения

Основные размеры

D – диаметр рабочей части
h – высота
b – ширина

Вид



Шлифование



Полирование



Отрезание



Зачистка

Профиль



1
Прямой



12
Тарельчатый



11
Чашечный

Связка



Водостойкость



Вид по назначению



Твердость



V
Керамическая



R
Вулканитовая



BF
Бакелитовая



Бумажная



Тканевая



Хлопчато-бумажная

Зерно



Тип зерна

Наличие инструмента

● На складе в Нижнем Новгороде

○ Под заказ

Инструмент на керамической связке

	Круги шлифовальные								
Тип зерна	25A	64С	14А	25А	64С	25А	64С		
Профиль	1 прямой профиль	1 прямой профиль	1 прямой профиль	11 чашечный профиль	11 чашечный профиль	12 тарельчатый профиль	12 тарельчатый профиль		
Связка	V керамическая	V керамическая	V керамическая	V керамическая	V керамическая	V керамическая	V керамическая		
Страница	892	898	901	902	903	904	905		



Головки шлифовальные

	Тип AW
Тип зерна	25А
Связка	V керамическая
Страница	906



Инструмент на гибкой основе

	Диски самозацепляющиеся	Лепестковые КЛ	Лепестковые КЛО		Лепестковые КЛТ1
Основа	Бумажная	Бумажная	Бумажная	Хлопчато-бумажная	Бумажная
Вид	—	—	—	—	—
Серия	—	КК19ХW	КК10ХW	КК19ХW	КК10ХW
Тип зерна	—	14А	14А	14А	14А
Страница	907	909	910	911	912



	Ленты шлифовальные бесконечные		Шкурки шлифовальные листовые			Шкурки шлифовальные рулонные	
Основа	Бумажная	Бумажная	Бумажная	Бумажная	—	Тканевая	Тканевая
Вид			Водостойкая	Водостойкая	Водостойкая	Водостойкая	Водостойкая
Серия	ZK10XW	—	СТ10СW	КТ10СW	—	КК19ХW	14А СФЖ У1С
Тип зерна	14А	—	—	—	—	—	—
Страница	913	914	915	916	917	918	919



Инструмент на бакелитовой связке

	Круги отрезные	Круги зачистные
Тип зерна	14A	14A
Назначение	Металл, нержавеющая сталь	Металл
Тип	S	R
Связка	BF бакелитовая	BF бакелитовая
Страница	920	921
		

Инструмент на вулканитовой связке

	Круги отрезные	Круги полировальные
Тип зерна	14A	14A
Связка	R вулканитовая	R вулканитовая
Страница	922	923
		

Шлифовальный материал

Страница	924
	

Круги шлифовальные 25A

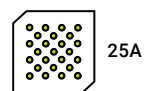
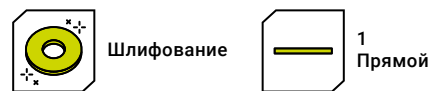

Артикул		D, мм	h, мм	D посадочного отверстия, мм	Зернистость	Твердость
1102818	○	80,0	10,0	20,0	F46	K/L
118025	○	80,0	10,0	20,0	F60	K/L
1102380	○	80,0	10,0	20,0	F60	O/P/Q
1108462	○	80,0	10,0	20,0	F80	K/L
1141030	○	80,0	10,0	20,0	F80	O/P/Q
118026	○	80,0	20,0	20,0	F46	K/L
116539	○	80,0	20,0	20,0	F60	K/L
1103073	○	80,0	32,0	20,0	F60	K/L
1425390	○	80,0	40,0	20,0	F60	K/L
1335585	○	80,0	50,0	20,0	F46	K/L
1379169	○	80,0	80,0	20,0	F60	O/P/Q
1477558	○	100,0	4,0	20,0	F100	K/L
1134655	○	100,0	4,0	20,0	F100	O/P/Q
1477559	○	100,0	6,0	20,0	F100	K/L
1109164	○	100,0	8,0	20,0	F60	O/P/Q
118040	○	100,0	10,0	20,0	F60	K/L
1289580	○	100,0	10,0	20,0	F80	K/L
1103111	●	100,0	20,0	20,0	F46	K/L
1425391	○	100,0	20,0	20,0	F46	O/P/Q
118027	●	100,0	20,0	20,0	F60	K/L
1104497	○	100,0	20,0	20,0	F60	O/P/Q
1234713	●	100,0	20,0	20,0	F80	K/L
118028	○	100,0	20,0	20,0	F120	K/L
1425755	○	100,0	20,0	20,0	F150	K/L
1237213	○	100,0	20,0	32,0	F40	K/L
1330972	○	125,0	8,0	32,0	F46	K/L
1151532	○	125,0	8,0	32,0	F150	K/L
1425394	○	125,0	10,0	32,0	F60	K/L
1252229	○	125,0	16,0	32,0	F60	K/L
1425395	○	125,0	20,0	20,0	F60	K/L
1612987	○	125,0	20,0	32,0	F46	K/L
1326207	○	125,0	20,0	32,0	F60	K/L
1177487	○	125,0	20,0	32,0	F60	O/P/Q
1335967	○	125,0	25,0	32,0	F46	K/L



Артикул		D, мм	h, мм	D посадочного отверстия, мм	Зернистость	Твердость
1584614	○	125,0	25,0	32,0	F46	O/P/Q
1584615	○	125,0	25,0	32,0	F60	K/L
1151531	○	125,0	32,0	32,0	F46	K/L
1323687	○	150,0	4,0	32,0	F60	K/L
1184178	○	150,0	4,0	32,0	F100	K/L
1258400	○	150,0	4,0	32,0	F100	O/P/Q
1149451	○	150,0	4,0	32,0	F150	O/P/Q
1518139	○	150,0	4,0	32,0	F180	K/L
1102623	○	150,0	6,0	32,0	F46	K/L
1102436	●	150,0	6,0	32,0	F60	K/L
1253837	○	150,0	6,0	32,0	F60	O/P/Q
1253732	●	150,0	6,0	32,0	F80	K/L
1253733	●	150,0	6,0	32,0	F80	O/P/Q
1614011	○	150,0	6,0	32,0	F100	K/L
1181255	○	150,0	6,0	32,0	F100	O/P/Q
1103116	○	150,0	6,0	32,0	F150	K/L
1584029	○	150,0	6,0	32,0	F150	O/P/Q
1323688	○	150,0	6,0	32,0	F180	O/P/Q
1110932	○	150,0	8,0	32,0	F46	K/L
1518162	○	150,0	8,0	32,0	F60	K/L
1105775	●	150,0	8,0	32,0	F80	K/L
1181256	○	150,0	8,0	32,0	F100	O/P/Q
1182159	○	150,0	8,0	32,0	F150	K/L
1184179	○	150,0	8,0	32,0	F180	K/L
1134121	●	150,0	10,0	32,0	F46	K/L
1108903	●	150,0	10,0	32,0	F60	K/L
1103119	●	150,0	10,0	32,0	F80	K/L
1585051	○	150,0	10,0	32,0	F100	K/L
1181257	○	150,0	10,0	32,0	F100	O/P/Q
1151530	○	150,0	10,0	32,0	F150	K/L
1184180	○	150,0	10,0	32,0	F180	K/L
1141086	○	150,0	13,0	32,0	F46	O/P/Q
1141087	○	150,0	13,0	32,0	F60	O/P/Q
1141088	○	150,0	13,0	32,0	F80	O/P/Q
1276432	○	150,0	16,0	20,0	F80	K/L
1102621	●	150,0	16,0	32,0	F46	K/L
1102435	●	150,0	16,0	32,0	F60	K/L
1109068	●	150,0	16,0	32,0	F80	K/L
1345935	○	150,0	16,0	32,0	F120	K/L

Артикул		D, мм	h, мм	D посадочного отверстия, мм	Зернистость	Твердость
1108904	●	150,0	20,0	32,0	F46	K/L
118768	●	150,0	20,0	32,0	F60	K/L
1418135	○	150,0	20,0	32,0	F60	O/P/Q
117832	●	150,0	20,0	32,0	F80	K/L
1377093	○	150,0	20,0	32,0	F120	K/L
1377094	○	150,0	20,0	32,0	F150	K/L
1105849	●	150,0	25,0	32,0	F46	K/L
1185489	○	150,0	25,0	32,0	F46	O/P/Q
116440	●	150,0	25,0	32,0	F60	K/L
1182625	○	150,0	25,0	32,0	F60	O/P/Q
1109165	○	150,0	25,0	32,0	F80	K/L
1149452	○	150,0	25,0	32,0	F80	O/P/Q
1326454	○	150,0	32,0	32,0	F46	K/L
1293105	○	150,0	32,0	32,0	F46	O/P/Q
1182682	○	150,0	32,0	32,0	F60	O/P/Q
1184284	○	150,0	32,0	32,0	F80	O/P/Q
1269741	○	150,0	40,0	32,0	F46	K/L
1292773	○	150,0	40,0	32,0	F60	K/L
1220819	○	175,0	8,0	32,0	F60	K/L
1379257	○	175,0	8,0	32,0	F80	K/L
1379256	○	175,0	8,0	32,0	F120	K/L
1252231	○	175,0	10,0	32,0	F46	K/L
1614012	○	175,0	10,0	32,0	F60	K
1256918	○	175,0	10,0	32,0	F60	K/L
1425400	○	175,0	10,0	32,0	F60	O/P/Q
1585053	○	175,0	10,0	32,0	F80	K/L
1135200	●	175,0	16,0	32,0	F46	K/L
1137584	●	175,0	16,0	32,0	F60	K/L
1585054	○	175,0	16,0	32,0	F80	K/L
117833	●	175,0	20,0	32,0	F46	K/L
118029	○	175,0	20,0	32,0	F46	O/P/Q
116540	●	175,0	20,0	32,0	F60	K/L
117928	○	175,0	20,0	32,0	F60	O/P/Q
1127371	○	175,0	20,0	32,0	F80	K/L
1105258	●	175,0	25,0	32,0	F46	K/L
1237616	●	175,0	25,0	32,0	F60	K/L
1425405	○	175,0	25,0	32,0	F60	O/P/Q
1182171	○	175,0	32,0	32,0	F46	K/L
1182172	○	175,0	32,0	32,0	F60	K/L

Артикул		D, мм	h, мм	D посадочного отверстия, мм	Зерни- стость	Твер- дость
1261767	○	175,0	40,0	32,0	F46	K/L
1323690	○	200,0	4,0	32,0	F60	K/L
1182160	○	200,0	6,0	32,0	F46	K/L
1293020	○	200,0	6,0	32,0	F60	K/L
1425408	○	200,0	6,0	32,0	F60	O/P/Q
1107338	○	200,0	6,0	32,0	F80	K/L
1181948	○	200,0	8,0	32,0	F46	K/L
1181949	○	200,0	8,0	32,0	F60	K/L
1107339	●	200,0	10,0	32,0	F46	K/L
1108544	●	200,0	10,0	32,0	F60	K/L
1258395	○	200,0	10,0	32,0	F60	O/P/Q
1326141	○	200,0	10,0	32,0	F80	K/L
1376921	○	200,0	10,0	32,0	F120	O/P/Q
1337591	○	200,0	12,0	32,0	F80	K/L
1151423	○	200,0	13,0	32,0	F46	K/L
1254867	○	200,0	13,0	32,0	F60	K/L
1185486	○	200,0	16,0	32,0	F46	K/L
1424768	○	200,0	16,0	32,0	F60	K/L
1582516	○	200,0	16,0	32,0	F80	K/L
116442	●	200,0	20,0	32,0	F46	K/L
1185050	○	200,0	20,0	32,0	F46	O/P/Q
116460	●	200,0	20,0	32,0	F60	K/L
1111402	○	200,0	20,0	32,0	F60	O/P/Q
1108901	●	200,0	20,0	32,0	F80	K/L
116542	○	200,0	20,0	32,0	F120	K/L
1479815	○	200,0	20,0	32,0	F180	K/L
1378221	○	200,0	20,0	76,0	F46	K/L
1289345	○	200,0	20,0	76,0	F60	K/L
1185481	○	200,0	20,0	76,0	F60	O/P/Q
1276643	○	200,0	20,0	76,0	F150	K/L
117252	●	200,0	25,0	32,0	F46	K/L
117243	○	200,0	25,0	32,0	F46	O/P/Q
116461	●	200,0	25,0	32,0	F60	K/L
1425412	○	200,0	25,0	32,0	F60	O/P/Q
1419453	○	200,0	25,0	32,0	F100	K/L
1182902	○	200,0	25,0	76,0	F46	K/L
1518163	○	200,0	25,0	76,0	F46	O/P/Q
1109347	○	200,0	25,0	76,0	F60	K/L
1729363	○	200,0	25,0	76,0	F80	K/L

Артикул		D, мм	h, мм	D посадочного отверстия, мм	Зерни- стость	Твер- дость
1102635	○	200,0	32,0	20,0	F60	K/L
1137918	●	200,0	32,0	32,0	F46	K/L
116544	●	200,0	32,0	32,0	F60	K/L
1289346	●	200,0	32,0	76,0	F46	K/L
1287084	●	200,0	32,0	76,0	F60	K/L
1337592	○	200,0	32,0	76,0	F80	K/L
1261768	○	200,0	40,0	32,0	F46	K/L
1376256	○	200,0	40,0	76,0	F46	K/L
1425415	○	200,0	40,0	76,0	F46	O/P/Q
1377468	○	200,0	40,0	76,0	F60	K/L
1237621	○	200,0	40,0	76,0	F60	O/P/Q
1185487	○	200,0	40,0	76,0	F80	O/P/Q
1379460	○	200,0	50,0	32,0	F80	K/L
1377103	○	250,0	4,0	76,0	F60	K/L
1377104	○	250,0	4,0	76,0	F80	K/L
1377105	○	250,0	5,0	76,0	F60	K/L
1377106	○	250,0	5,0	76,0	F80	K/L
1242027	○	250,0	6,0	32,0	F46	K/L
1330892	○	250,0	6,0	32,0	F60	K/L
1261735	○	250,0	6,0	76,0	F46	K/L
1132289	○	250,0	8,0	32,0	F46	K/L
1105463	○	250,0	10,0	32,0	F46	K/L
1177485	○	250,0	10,0	32,0	F46	O/P/Q
1102624	○	250,0	10,0	32,0	F60	K/L
1425417	○	250,0	10,0	76,0	F46	K/L
1240880	○	250,0	10,0	76,0	F60	K/L
1131820	○	250,0	10,0	76,0	F80	O/P/Q
1182173	○	250,0	13,0	32,0	F46	K/L
1182174	○	250,0	13,0	32,0	F60	K/L
1240881	○	250,0	13,0	76,0	F60	K/L
1425418	○	250,0	16,0	76,0	F46	K/L
1240882	○	250,0	16,0	76,0	F60	K/L
1613130	○	250,0	20,0	32,0	F36	K/L
1176080	○	250,0	20,0	32,0	F46	K/L
116545	●	250,0	20,0	32,0	F60	K/L
117245	●	250,0	20,0	76,0	F46	K/L
1108902	●	250,0	20,0	76,0	F60	K/L
1107992	○	250,0	20,0	76,0	F60	O/P/Q
1185682	○	250,0	20,0	76,0	F80	O/P/Q

Артикул		D, мм	h, мм	D посадочного отверстия, мм	Зерни- стость	Твер- дость
1582544	○	250,0	20,0	76,0	F120	O
1582545	○	250,0	20,0	76,0	F150	P/Q
116546	●	250,0	25,0	32,0	F46	K/L
1185482	○	250,0	25,0	32,0	F46	O/P/Q
1258399	●	250,0	25,0	32,0	F60	K/L
116443	●	250,0	25,0	76,0	F46	K/L
1252234	○	250,0	25,0	76,0	F46	O/P/Q
116444	●	250,0	25,0	76,0	F60	K/L
1109069	○	250,0	25,0	76,0	F60	O/P/Q
1137582	○	250,0	25,0	76,0	F80	K/L
1276645	○	250,0	25,0	76,0	F150	K/L
1103324	●	250,0	32,0	32,0	F46	K/L
117244	○	250,0	32,0	32,0	F46	O/P/Q
1378583	●	250,0	32,0	32,0	F60	K/L
1342939	○	250,0	32,0	32,0	F120	K/L
1108675	●	250,0	32,0	76,0	F46	K/L
1326559	○	250,0	32,0	76,0	F46	O/P/Q
1425420	○	250,0	32,0	76,0	F54	K/L
1240883	●	250,0	32,0	76,0	F60	K/L
1377107	○	250,0	32,0	76,0	F80	K/L
1131819	○	250,0	32,0	76,0	F80	O/P/Q
1582921	○	250,0	40,0	32,0	F46	K/L
118030	●	250,0	40,0	76,0	F46	K/L
1124610	●	250,0	40,0	76,0	F60	K/L
1377108	○	250,0	40,0	76,0	F80	K/L
1242751	○	250,0	40,0	127,0	F60	O/P/Q
1584616	○	250,0	100,0	127,0	F60	K/L
1425227	○	300,0	8,0	127,0	F46	K/L
1148085	○	300,0	10,0	76,0	F46	K/L
1237598	○	300,0	10,0	76,0	F60	K/L
1613431	○	300,0	10,0	76,0	F120	O/P/Q
1139299	○	300,0	10,0	127,0	F46	K/L
1584617	○	300,0	10,0	127,0	F60	K/L
1242896	○	300,0	10,0	127,0	F80	O/P/Q
1376954	○	300,0	20,0	76,0	F46	K/L
1237601	○	300,0	20,0	76,0	F60	K/L
1378396	○	300,0	20,0	127,0	F60	K/L
1267676	○	300,0	20,0	127,0	F80	O/P/Q
1418484	○	300,0	20,0	127,0	F100	K/L

Артикул		D, мм	h, мм	D посадочного отверстия, мм	Зерни- стость	Твер- дость
1177012	○	300,0	25,0	76,0	F46	K/L
1177036	○	300,0	25,0	76,0	F60	K/L
1582514	○	300,0	25,0	127,0	F60	K/L
1591780	○	300,0	25,0	127,0	F80	K/L
1267677	○	300,0	25,0	127,0	F80	O/P/Q
1615022	○	300,0	25,0	127,0	F90	K/L
118698	○	300,0	32,0	76,0	F46	K/L
118699	○	300,0	32,0	76,0	F60	K/L
1227146	○	300,0	32,0	127,0	F46	K/L
1326560	○	300,0	32,0	127,0	F46	O/P/Q
1284352	○	300,0	32,0	127,0	F60	K/L
116549	●	300,0	40,0	76,0	F46	K/L
1110196	○	300,0	40,0	76,0	F46	O/P/Q
116447	●	300,0	40,0	76,0	F60	K/L
1378397	○	300,0	40,0	76,0	F60	O/P/Q
1135774	○	300,0	40,0	76,0	F80	K/L
1326469	○	300,0	40,0	76,0	F80	O/P/Q
1613432	○	300,0	40,0	76,0	F120	O/P/Q
116448	●	300,0	40,0	127,0	F46	K/L
1177038	●	300,0	40,0	127,0	F46	O/P/Q
116449	●	300,0	40,0	127,0	F60	K/L
1184235	●	300,0	40,0	127,0	F60	O/P/Q
1138188	●	300,0	40,0	127,0	F80	K/L
1182901	●	300,0	40,0	127,0	F80	O/P/Q
1326455	○	300,0	100,0	127,0	F60	O/P/Q
1378322	○	350,0	10,0	127,0	F46	K/L
1418049	○	350,0	10,0	127,0	F80	O/P/Q
1150260	○	350,0	16,0	127,0	F60	K/L
1597459	○	350,0	20,0	127,0	F46	K/L
1185985	○	350,0	20,0	127,0	F80	O/P/Q
1105817	○	350,0	25,0	127,0	F46	K/L
1102898	○	350,0	25,0	127,0	F60	K/L
1128661	○	350,0	25,0	127,0	F60	O/P/Q
1409788	○	350,0	32,0	127,0	F46	K/L
1379461	○	350,0	32,0	127,0	F60	K/L
1265226	○	350,0	32,0	127,0	F80	K/L
116452	●	350,0	40,0	127,0	F46	K/L
1131446	●	350,0	40,0	127,0	F46	O/P/Q
1425426	○	350,0	40,0	127,0	F54	K/L

Артикул		D, мм	h, мм	D посадочного отверстия, мм	Зернистость	Твердость
116453	●	350,0	40,0	127,0	F60	K/L
1242750	○	350,0	40,0	127,0	F60	O/P/Q
1335496	○	350,0	40,0	127,0	F80	K/L
1342940	○	350,0	40,0	127,0	F120	K/L
1378222	○	350,0	40,0	203,0	F60	K/L
1342941	○	350,0	50,0	127,0	F36	K/L
1273104	○	350,0	50,0	127,0	F46	K/L
1138830	○	350,0	50,0	127,0	F60	K/L
1182844	○	350,0	50,0	203,0	F60	K/L
1182845	○	350,0	50,0	203,0	F80	K/L
1330974	○	350,0	100,0	127,0	F46	K/L
1132393	○	350,0	100,0	127,0	F60	K/L
1110933	○	350,0	100,0	203,0	F46	K/L
1182847	○	350,0	100,0	203,0	F60	K/L
1179431	○	350,0	100,0	203,0	F60	O/P/Q
1109790	○	350,0	100,0	203,0	F80	O/P/Q
1269742	○	400,0	8,0	203,0	F120	K/L
1260622	○	400,0	8,0	203,0	F180	O/P/Q
1326139	○	400,0	10,0	127,0	F60	K/L
1252556	○	400,0	10,0	203,0	F60	K/L
1252557	○	400,0	10,0	203,0	F80	K/L
1342911	○	400,0	10,0	203,0	F100	K/L
1104403	○	400,0	10,0	203,0	F120	K/L
1323689	○	400,0	12,0	203,0	F46	K/L
1252558	○	400,0	12,0	203,0	F60	K/L
1252559	○	400,0	12,0	203,0	F80	K/L
1131444	○	400,0	16,0	127,0	F80	K/L
1144823	○	400,0	16,0	127,0	F80	O/P/Q
1149351	○	400,0	16,0	127,0	F120	O/P/Q
1103076	○	400,0	16,0	203,0	F60	K/L
1252560	○	400,0	16,0	203,0	F80	K/L
1182428	○	400,0	16,0	203,0	F80	O/P/Q
1135199	○	400,0	20,0	127,0	F60	O/P/Q
1417205	○	400,0	20,0	127,0	F80	K/L
1127369	○	400,0	20,0	127,0	F80	O/P/Q
1185483	○	400,0	20,0	203,0	F60	K/L
1252235	○	400,0	20,0	203,0	F80	K/L
1326140	○	400,0	20,0	203,0	F80	O/P/Q
1149344	○	400,0	25,0	127,0	F60	K/L
1417208	○	400,0	25,0	127,0	F80	K/L

Артикул		D, мм	h, мм	D посадочного отверстия, мм	Зернистость	Твердость
1416296	○	400,0	25,0	127,0	F120	K/L
1131445	○	400,0	25,0	203,0	F60	K/L
117246	●	400,0	40,0	127,0	F46	K/L
1179434	●	400,0	40,0	127,0	F46	O/P/Q
117247	●	400,0	40,0	127,0	F60	K/L
1179435	○	400,0	40,0	127,0	F60	O/P/Q
118041	○	400,0	40,0	127,0	F80	K/L
1124730	●	400,0	40,0	127,0	F80	O/P/Q
119490	●	400,0	40,0	203,0	F46	K/L
1124611	●	400,0	40,0	203,0	F46	O/P/Q
118968	●	400,0	40,0	203,0	F60	K/L
1185051	○	400,0	40,0	203,0	F60	O/P/Q
1220548	○	400,0	40,0	203,0	F80	O/P/Q
1379468	●	400,0	50,0	127,0	F46	K/L
1478439	○	400,0	50,0	127,0	F46	O/P/Q
1425433	○	400,0	50,0	127,0	F54	K/L
1137585	●	400,0	50,0	127,0	F60	K/L
1584280	○	400,0	50,0	127,0	F80	K/L
1139297	○	400,0	50,0	203,0	F36	O/P/Q
1151424	●	400,0	50,0	203,0	F46	K/L
1137583	○	400,0	50,0	203,0	F46	O/P/Q
1286953	●	400,0	50,0	203,0	F60	K/L
1254886	○	400,0	50,0	203,0	F60	O/P/Q
1342942	○	400,0	50,0	203,0	F120	K/L
1263089	○	400,0	63,0	203,0	F46	K/L
1243691	○	400,0	63,0	203,0	F60	K/L
1584621	○	400,0	80,0	203,0	F46	K/L
1108478	○	400,0	80,0	203,0	F60	K/L
1185986	○	400,0	80,0	203,0	F80	K/L
1417206	○	400,0	100,0	203,0	F60	K/L
1293019	○	450,0	32,0	127,0	F46	K/L
1273106	○	450,0	32,0	127,0	F54	K/L
1103109	○	450,0	40,0	127,0	F46	K/L
1376922	○	450,0	40,0	127,0	F60	K/L
117924	○	450,0	50,0	127,0	F80	O/P/Q
1108899	○	450,0	50,0	203,0	F46	K/L
1104400	●	450,0	63,0	203,0	F46	K/L
1124613	○	450,0	63,0	203,0	F46	O/P/Q
1102966	●	450,0	63,0	203,0	F60	K/L
1149353	○	450,0	63,0	203,0	F60	O/P/Q

Артикул		D, мм	h, мм	D посадочного отверстия, мм	Зернистость	Твердость
1262839	○	450,0	63,0	203,0	F80	K/L
1417309	○	450,0	63,0	203,0	F120	K/L
1346038	○	450,0	80,0	203,0	F36	K/L
1104875	●	450,0	80,0	203,0	F46	K/L
116553	●	450,0	80,0	203,0	F60	K/L
1252221	○	450,0	80,0	203,0	F100	K/L
1416675	○	450,0	100,0	203,0	F46	K/L
1252230	○	500,0	32,0	203,0	F46	K/L
1377109	○	500,0	32,0	203,0	F60	K/L
1377111	○	500,0	32,0	203,0	F60	O/P/Q
1220546	○	500,0	32,0	203,0	F100	K/L
1378584	○	500,0	32,0	203,0	F120	K/L
1326561	○	500,0	40,0	203,0	F80	K/L
1418440	○	500,0	50,0	203,0	F60	K/L
1335837	○	500,0	50,0	203,0	F60	O/P/Q
1103110	○	500,0	63,0	203,0	F46	K/L
1103112	○	500,0	63,0	203,0	F60	K/L
1147183	○	500,0	63,0	305,0	F60	K/L
1103113	○	500,0	80,0	203,0	F60	K/L
1378552	○	500,0	100,0	305,0	F46	K/L
1182683	○	500,0	100,0	305,0	F60	K/L
1260623	○	500,0	100,0	305,0	F60	O/P/Q
119366	○	500,0	150,0	305,0	F46	K/L
1149349	○	500,0	150,0	305,0	F60	K/L
119165	○	500,0	150,0	305,0	F60	O/P/Q
1139298	○	500,0	150,0	305,0	F80	O/P/Q

Артикул		D, мм	h, мм	D посадочного отверстия, мм	Зернистость	Твердость
1477757	○	600,0	32,0	305,0	F46	K/L
1530958	○	600,0	40,0	305,0	F46	K/L
1289477	○	600,0	40,0	305,0	F80	O/P/Q
1584567	○	600,0	50,0	203,0	F46	K/L
1583535	○	600,0	50,0	203,0	F60	K/L
1186488	○	600,0	50,0	305,0	F46	K/L
1186489	○	600,0	50,0	305,0	F60	K/L
1177009	○	600,0	50,0	305,0	F60	M/N
1418160	○	600,0	63,0	203,0	F46	K/L
1418161	○	600,0	63,0	203,0	F60	O/P/Q
1379259	○	600,0	63,0	305,0	F36	K/L
117529	○	600,0	63,0	305,0	F46	K/L
1105257	○	600,0	63,0	305,0	F46	O/P/Q
1102967	○	600,0	63,0	305,0	F60	K/L
1128636	○	600,0	63,0	305,0	F60	O/P/Q
1105291	○	600,0	63,0	305,0	F80	O/P/Q
1284386	○	600,0	63,0	305,0	F120	K/L
1110935	○	600,0	80,0	305,0	F46	K/L
1104876	○	600,0	80,0	305,0	F46	O/P/Q
1108633	○	600,0	80,0	305,0	F60	K/L
1284385	○	600,0	100,0	305,0	F46	K/L
1418162	○	600,0	100,0	305,0	F46	O/P/Q
1416270	○	750,0	40,0	305,0	F60	K/L
1335497	○	750,0	75,0	305,0	F60	K/L
1583758	○	750,0	80,0	305,0	F46	K/L
1237620	○	750,0	80,0	305,0	F60	K/L

Круги шлифовальные 64С

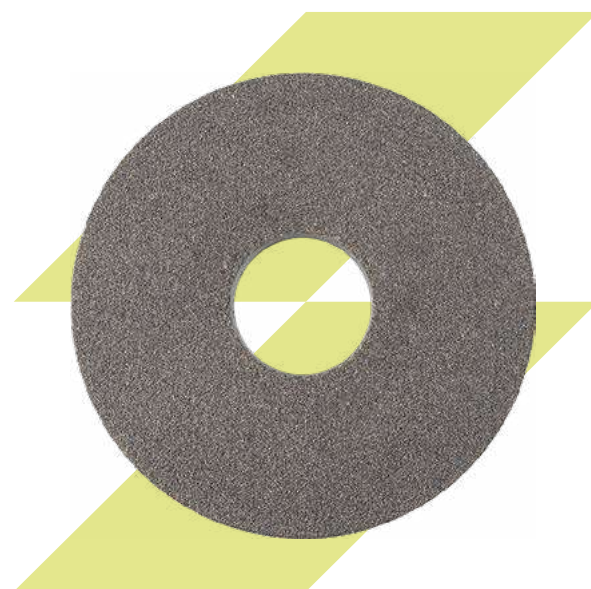
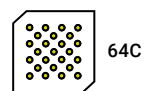







Артикул		D, мм	h, мм	D посадочного отверстия, мм	Зернистость	Твердость
1127373	○	80,0	20,0	20,0	F46	K/L
1227145	○	100,0	10,0	20,0	F46	K/L
1129990	○	100,0	20,0	20,0	F46	K/L
1425393	○	100,0	20,0	20,0	F46	O/P/Q
1582375	○	125,0	16,0	32,0	F60	K/L
1185809	○	125,0	32,0	32,0	F46	K/L
1102440	○	150,0	6,0	32,0	F46	K/L
1585175	○	150,0	8,0	32,0	F100	K/L
1326558	○	150,0	10,0	32,0	F60	K/L
1102622	○	150,0	16,0	32,0	F46	K/L
1110685	○	150,0	16,0	32,0	F60	K/L
1425135	○	150,0	16,0	32,0	F120	K/L
1134656	●	150,0	20,0	32,0	F46	K/L
118931	●	150,0	20,0	32,0	F60	K/L
1256917	○	150,0	20,0	32,0	F60	O/P/Q
118969	○	150,0	20,0	32,0	F80	K/L
1531145	○	150,0	20,0	32,0	F80	O/P/Q
1425136	○	150,0	20,0	32,0	F150	K/L
1102438	●	150,0	25,0	32,0	F46	K/L
1102626	●	150,0	25,0	32,0	F60	K/L
1425398	○	150,0	25,0	32,0	F60	M/N
1131821	●	150,0	25,0	32,0	F60	O/P/Q
1425401	○	175,0	10,0	32,0	F60	K/L
1425402	○	175,0	10,0	32,0	F60	O/P/Q
1269616	○	175,0	16,0	32,0	F60	K/L
1105255	●	175,0	20,0	32,0	F46	K/L
1378227	○	175,0	20,0	32,0	F46	O/P/Q
116541	●	175,0	20,0	32,0	F60	K/L
1425404	○	175,0	20,0	32,0	F60	M/N
1377095	○	175,0	20,0	32,0	F60	O/P/Q
1109788	○	175,0	20,0	32,0	F80	K/L
1238335	○	175,0	25,0	32,0	F46	K/L
1583274	○	175,0	25,0	32,0	F60	K/L
1425407	○	175,0	25,0	32,0	F60	O/P/Q

Артикул		D, мм	h, мм	D посадочного отверстия, мм	Зернистость	Твердость
1323544	○	175,0	32,0	32,0	F100	K/L
1108900	○	200,0	10,0	32,0	F46	K/L
1105850	○	200,0	10,0	32,0	F60	K/L
1149345	○	200,0	10,0	32,0	F80	K/L
1258392	○	200,0	16,0	32,0	F60	K/L
116543	●	200,0	20,0	32,0	F46	K/L
117248	●	200,0	20,0	32,0	F60	K/L
1425410	○	200,0	20,0	32,0	F80	K/L
116463	●	200,0	25,0	32,0	F46	K/L
119489	○	200,0	25,0	32,0	F46	O/P/Q
1107341	●	200,0	25,0	32,0	F60	K/L
1269617	○	200,0	25,0	32,0	F60	O/P/Q
1582824	○	200,0	25,0	76,0	F60	K/L
1425413	○	200,0	32,0	32,0	F46	O/P/Q
1409670	○	200,0	32,0	32,0	F60	K/L
1425414	●	200,0	32,0	76,0	F46	K/L
1287085	●	200,0	32,0	76,0	F60	K/L
1425416	○	200,0	40,0	76,0	F46	K/L
1104402	○	250,0	10,0	32,0	F46	K/L
1102625	○	250,0	10,0	32,0	F60	K/L
1330973	○	250,0	20,0	32,0	F46	K/L
1331219	○	250,0	20,0	32,0	F60	K/L
1480642	○	250,0	20,0	76,0	F60	K/L
1109539	○	250,0	20,0	76,0	F60	O/P/Q
1109315	○	250,0	25,0	32,0	F46	K/L
1417938	○	250,0	25,0	32,0	F60	K/L
116445	○	250,0	25,0	76,0	F46	K/L
1109540	○	250,0	25,0	76,0	F60	K/L
1108616	○	250,0	25,0	76,0	F60	O/P/Q
1109322	○	250,0	25,0	76,0	F80	K/L
1256919	○	250,0	32,0	32,0	F46	K/L
117251	○	250,0	32,0	32,0	F46	O/P/Q
1269618	●	250,0	32,0	32,0	F60	K/L
1343244	○	250,0	32,0	32,0	F60	O/P/Q
1177486	○	250,0	32,0	76,0	F46	K/L
1582922	○	250,0	40,0	32,0	F46	K/L
1584724	○	250,0	40,0	32,0	F60	K/L
116446	●	250,0	40,0	76,0	F46	K/L
1260308	●	250,0	40,0	76,0	F60	K/L









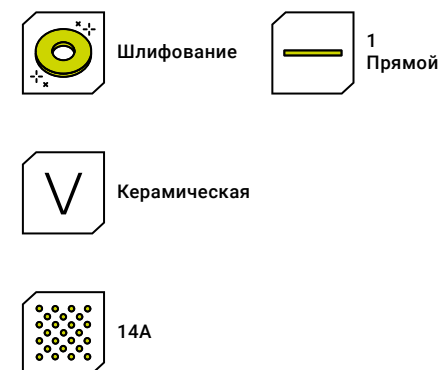













Артикул		D, мм	h, мм	D посадочного отверстия, мм	Зернистость	Твердость
1418157	○	300,0	32,0	76,0	F46	K/L
1425424	○	300,0	40,0	76,0	F36	K/L
116550	●	300,0	40,0	76,0	F46	K/L
1131818	○	300,0	40,0	76,0	F46	O/P/Q
117249	●	300,0	40,0	76,0	F60	K/L
1425425	○	300,0	40,0	76,0	F60	O/P/Q
1103120	○	300,0	40,0	76,0	F80	K/L
1418158	○	300,0	40,0	76,0	F100	K/L
1729409	○	300,0	40,0	127,0	F36	K/L
116450	●	300,0	40,0	127,0	F46	K/L
1236948	○	300,0	40,0	127,0	F46	O/P/Q
116451	●	300,0	40,0	127,0	F60	K/L
1265668	○	300,0	40,0	127,0	F60	O/P/Q
1330930	○	350,0	25,0	127,0	F60	K/L
1409789	○	350,0	32,0	127,0	F46	K/L
1379462	○	350,0	32,0	127,0	F60	K/L
1425427	○	350,0	40,0	127,0	F36	K/L
1104399	●	350,0	40,0	127,0	F46	K/L
1337805	○	350,0	40,0	127,0	F46	O/P/Q
116551	●	350,0	40,0	127,0	F60	K/L
1418159	○	350,0	40,0	127,0	F80	K/L
1273105	○	350,0	50,0	127,0	F60	K/L
1337490	○	350,0	50,0	203,0	F60	K/L
1149350	○	350,0	100,0	203,0	F60	K/L
1185810	○	350,0	100,0	203,0	F80	O/P/Q
1289525	○	400,0	25,0	203,0	F60	O/P/Q
1425430	○	400,0	40,0	127,0	F36	K/L
116455	●	400,0	40,0	127,0	F46	K/L
1425432	○	400,0	40,0	127,0	F46	O/P/Q
117254	●	400,0	40,0	127,0	F60	K/L
1182623	○	400,0	40,0	127,0	F60	O/P/Q
1237619	○	400,0	40,0	127,0	F80	K/L
1182624	○	400,0	40,0	127,0	F80	O/P/Q
119488	●	400,0	40,0	203,0	F46	K/L
118034	●	400,0	40,0	203,0	F60	K/L
1289526	○	400,0	40,0	203,0	F60	O/P/Q
1323525	○	400,0	40,0	203,0	F180	O/P/Q
1425434	○	400,0	50,0	127,0	F36	K/L
119359	○	400,0	50,0	127,0	F46	K/L

Артикул		D, мм	h, мм	D посадочного отверстия, мм	Зернистость	Твердость
1181950		400,0	50,0	203,0	F46	K/L
1181951		400,0	50,0	203,0	F60	K/L
1740162		400,0	63,0	203,0	F100	K/L
1109167		450,0	50,0	203,0	F46	K/L
1262840		450,0	63,0	203,0	F46	K/L
1105256		500,0	63,0	203,0	F46	K/L
1104401		500,0	63,0	203,0	F60	K/L

Артикул		D, мм	h, мм	D посадочного отверстия, мм	Зернистость	Твердость
1105259		500,0	63,0	305,0	F46	K/L
1379258		500,0	150,0	305,0	F80	O/P/Q
119357		600,0	63,0	305,0	F46	K/L
119358		600,0	63,0	305,0	F60	K/L
1149453		600,0	80,0	305,0	F60	K/L
1583536		750,0	80,0	305,0	F60	K/L

Круги шлифовальные 14А



Артикул		D, мм	h, мм	D посадочного отверстия, мм	Зернистость	Твердость
1584910		150,0	13,0	32,0	F80	O/P/Q
1179432		150,0	20,0	32,0	F60	K/L
1150259		150,0	20,0	32,0	F80	K/L
1425403		175,0	20,0	32,0	F60	O/P/Q
1177011		200,0	10,0	32,0	F60	K/L
1480643		250,0	25,0	76,0	F46	K/L
1480645		250,0	25,0	76,0	F46	O/P/Q
1480646		250,0	25,0	76,0	F60	K/L
1518061		250,0	25,0	76,0	F90	K/L
1337593		250,0	32,0	76,0	F46	K/L
1237617		250,0	40,0	76,0	F60	K/L
118032		300,0	40,0	76,0	F46	O/P/Q
118033		300,0	40,0	127,0	F60	O/P/Q
1237618		350,0	40,0	127,0	F60	K/L
1265227		400,0	40,0	127,0	F60	K/L
1252233		400,0	40,0	127,0	F60	O/P/Q
1585113		400,0	40,0	203,0	F46	O/P/Q
1729345		400,0	40,0	203,0	F60	K/L
118035		450,0	63,0	203,0	F46	K/L
1242038		500,0	200,0	305,0	F60	O/P/Q
1330819		500,0	250,0	305,0	F60	O/P/Q
1740103		750,0	80,0	305,0	F46	K/L

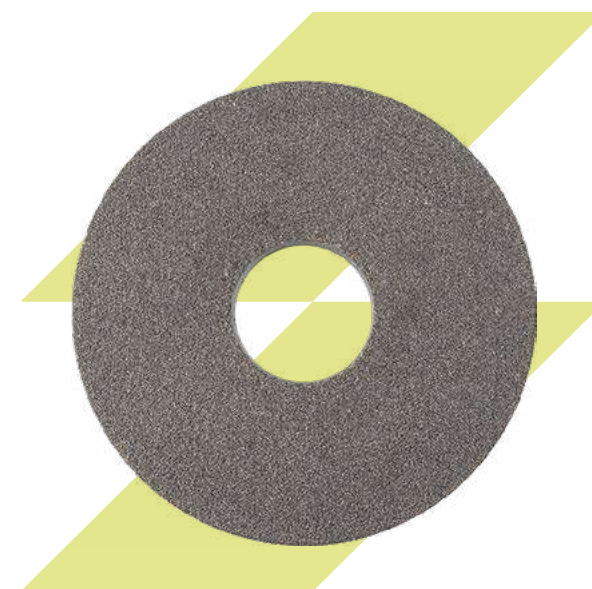

Круги шлифовальные 25А чашечные

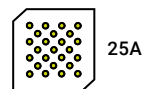

Артикул	D, мм	h, мм	D посадочного отверстия, мм	Зернистость	Твердость
1425447	80,0	32,0	20,0	F60	K/L
1425448	80,0	32,0	20,0	F80	K/L
1134654	80,0	40,0	20,0	F46	K/L
1108615	100,0	40,0	20,0	F60	K/L
1329731	125,0	40,0	32,0	F60	K/L
1330893	125,0	45,0	32,0	F40	O/P/Q
1269465	125,0	45,0	32,0	F46	K/L
1110687	125,0	50,0	32,0	F46	K/L
1425450	125,0	50,0	32,0	F60	K/L
1379261	150,0	40,0	32,0	F46	K/L
1110898	150,0	40,0	32,0	F60	K/L
117431	150,0	50,0	32,0	F46	K/L
117430	150,0	50,0	32,0	F60	K/L
1740490	175,0	63,0	32,0	F46	K/L



Круги шлифовальные 64С чашечные

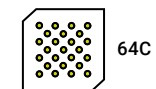

Артикул	D, мм	h, мм	D посадочного отверстия, мм	Зернистость	Твердость
1110899	150,0	40,0	32,0	F60	K/L
117153	150,0	50,0	32,0	F46	K/L
1107993	150,0	50,0	32,0	F60	K/L
117253	150,0	50,0	32,0	F60	O/P/Q



Круги шлифовальные 25A тарельчатые

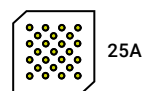

Артикул	D, мм	h, мм	D посадочного отверстия, мм	Зернистость	Твердость
1379171	80,0	8,0	13,0	F46	K/L
1441761	80,0	8,0	13,0	F60	K/L
1441762	80,0	8,0	13,0	F100	O/P/Q
1425454	100,0	13,0	20,0	F60	K/L
118933	150,0	16,0	32,0	F46	K/L
117429	150,0	16,0	32,0	F60	K/L
1378223	150,0	16,0	32,0	F60	O/P/Q
1107994	150,0	16,0	32,0	F80	K/L
1441765	150,0	16,0	32,0	F100	O/P/Q
118935	175,0	16,0	32,0	F46	K/L
118936	175,0	16,0	32,0	F60	K/L
1124612	175,0	16,0	32,0	F80	K/L
1260309	175,0	20,0	32,0	F60	K/L
1425456	200,0	16,0	32,0	F80	K/L
1105466	200,0	20,0	32,0	F46	K/L
118937	200,0	20,0	32,0	F60	K/L
1479509	250,0	20,0	32,0	F60	K/L



Круги шлифовальные 64C тарельчатые

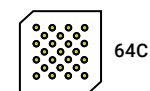

Артикул	D, мм	h, мм	D посадочного отверстия, мм	Зернистость	Твердость
1425453	100,0	10,0	20,0	F46	K/L
1379463	125,0	13,0	32,0	F60	K/L
1379464	125,0	13,0	32,0	F80	K/L
1102439	150,0	16,0	32,0	F60	K/L
1596916	150,0	16,0	32,0	F60	O/P/Q
1379465	150,0	16,0	32,0	F80	K/L
1596917	150,0	16,0	32,0	F80	O/P/Q
1284751	175,0	16,0	32,0	F60	K/L
116554	200,0	20,0	32,0	F46	K/L
1729346	200,0	20,0	32,0	F60	K/L
1175708	250,0	20,0	32,0	F46	K/L
1175709	250,0	20,0	32,0	F60	K/L



Головки шлифовальные 25А



Шлифование



Керамическая



25А

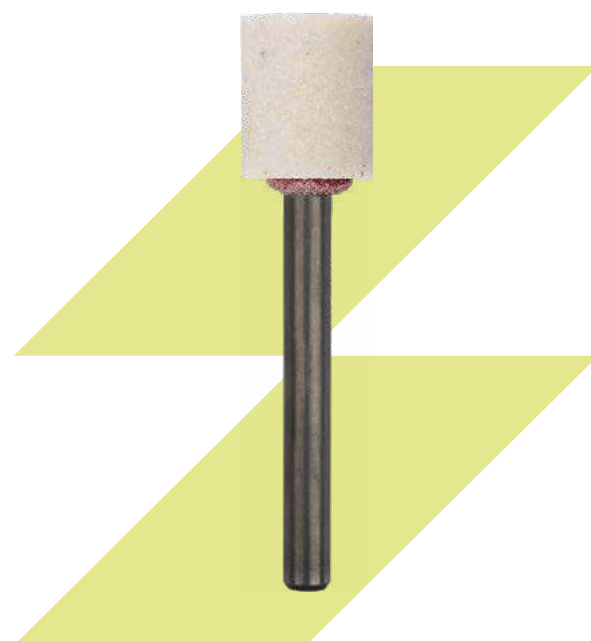

Артикул		D, мм	h, мм	D хвостовика, мм	Зерни- стость	Твер- дость
1109327	●	3,0	6,0	3,0	16-H	СТ3
1109328	●	4,0	10,0	3,0	16-H	СТ3
1110905	●	5,0	10,0	3,0	16-H	СТ3
1109329	●	6,0	10,0	3,0	25-H	СТ3
1109330	●	8,0	10,0	3,0	25-H	СТ3
1109331	●	10,0	10,0	3,0	25-H	СТ3
1103638	●	10,0	15,0	3,0	25-H	СТ3
1220821	●	10,0	25,0	3,0	25-H	С1
1109332	○	10,0	25,0	3,0	25-H	С2
1103639	●	10,0	25,0	3,0	25-H	СТ2
1252555	●	10,0	25,0	6,0	25-H	С1
1343011	●	10,0	25,0	6,0	40-H	СТ1
1109333	●	13,0	16,0	6,0	25-H	СТ2
1109334	●	16,0	20,0	6,0	25-H	СТ2
1109335	●	20,0	25,0	6,0	25-H	СТ2
1251444	●	20,0	25,0	6,0	25-H	СТ3
1326234	●	20,0	32,0	6,0	16-H	С1
1109183	●	25,0	25,0	6,0	16-H	СМ2
1109182	●	25,0	25,0	6,0	16-H	СТ2
1331300	●	25,0	25,0	6,0	25-H	СТ1
1326235	●	32,0	32,0	6,0	16-H	СТ1
1110906	●	32,0	40,0	6,0	25-H	СТ2
1331301	●	40,0	20,0	6,0	25-H	СТ2

Диски самосцепляющиеся



Бумажная



Артикул		D, мм	Зерни- стость	Серия
1846922	●	125,0	P40	КР10D
1167184	○	125,0	P40	КР10E
1846923	●	125,0	P60	КР10D
1102281	○	125,0	P60	КР10E
1772586	●	125,0	P80	КР10D
1102280	○	125,0	P80	КР10E
1764344	●	125,0	P100	КР10D
1129988	○	125,0	P100	КР10E
1764345	●	125,0	P120	КР10D
1129989	○	125,0	P120	КР10E
1846942	○	125,0	P180	КР10D
1337494	○	125,0	P180	КР10E
1764346	●	125,0	P240	КР10D
1140354	○	125,0	P240	КР10E
1615199	○	125,0	P280	КР10F
1337496	●	125,0	P320	КР10E
1614424	○	125,0	P400	КР10С
1337497	○	125,0	P400	КР10E
1337498	○	125,0	P600	КТ10СW
1634430	○	125,0	P800	КТ10СW
1614425	○	125,0	P1000	КТ10СW
1852748	○	125,0	P1200	КТ10СW
1784523	●	150,0	P40	КР10D
118007	○	150,0	P40	КР10E
1323639	●	150,0	P60	КР10E
1784524	●	150,0	P80	КР10D
118008	○	150,0	P80	КР10E
1615158	○	150,0	P100	КР10E
1846515	○	150,0	P120	КР10D
1326146	○	150,0	P120	КР10E
1615159	○	150,0	P150	КР10E
1418758	○	150,0	P180	КР10E
1265341	○	150,0	P240	КР10E
1613215	○	150,0	P320	КМ10

Артикул		D, мм	Зернистость	Серия
1657327	○	150,0	P400	KM10
1584118	○	150,0	P600	KT20CW
1583851	○	150,0	P800	CT20CW
1612507	○	150,0	P1000	KM10
1612508	○	150,0	P1200	KM10
1612509	○	150,0	P1500	KM10

Артикул		D, мм	Зернистость	Серия
1847466	○	150,0	P2000	KM10
1377047	○	200,0	P40	KP10E
1377127	○	200,0	P80	KP10E
1377128	○	200,0	P320	KP10E
1377129	○	200,0	P600	KT10CW
1377130	○	200,0	P1200	KT10CW

Круги лепестковые КЛ КК19ХВ

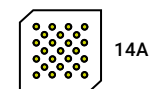

Артикул		D, мм	h, мм	D посадочного отверстия, мм	Зернистость
1239992	●	150,0	30,0	32,0	6-H
102314	●	150,0	30,0	32,0	10-H
102315	●	150,0	30,0	32,0	12-H
102316	●	150,0	30,0	32,0	16-H
102317	●	150,0	30,0	32,0	25-H
102318	○	150,0	30,0	32,0	32-H
1102364	●	150,0	30,0	32,0	40-H
1102365	○	150,0	50,0	32,0	40-H
1110346	○	200,0	50,0	32,0	10-H
118116	○	200,0	50,0	32,0	16-H
1110347	○	200,0	50,0	32,0	25-H



Круги лепестковые с оправкой КЛО КК10ХW

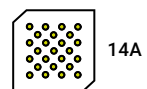

Артикул		D, мм	h, мм	D хвостовика, мм	Зернистость
1378399	○	30,0	30,0	6,0	P40
1243695	●	30,0	30,0	6,0	P60
1243697	●	30,0	30,0	6,0	P80
1378400	○	40,0	20,0	6,0	P40
1240709	●	40,0	20,0	6,0	P60
1104474	●	40,0	20,0	6,0	P80
1378560	○	40,0	20,0	6,0	P150
1378561	○	40,0	30,0	6,0	P40
1323549	○	50,0	20,0	6,0	P24
1323550	○	50,0	20,0	6,0	P40
1243696	○	50,0	20,0	6,0	P60
1243698	○	50,0	20,0	6,0	P80
1104471	○	50,0	30,0	6,0	P60
1582949	○	50,0	30,0	6,0	P80
1379185	○	60,0	20,0	6,0	P60
1104244	●	60,0	30,0	6,0	P40
1258358	●	60,0	30,0	6,0	P60
1418605	○	60,0	30,0	6,0	P120
1740101	○	60,0	50,0	6,0	P50
1104470	○	60,0	50,0	6,0	P60
1418606	○	60,0	50,0	6,0	P80
1418607	○	60,0	50,0	6,0	P120
1110164	○	80,0	20,0	6,0	P60
1243699	●	80,0	30,0	6,0	P40
1243700	○	80,0	30,0	6,0	P60
1184188	○	80,0	40,0	6,0	P100
1585458	○	80,0	50,0	6,0	P80

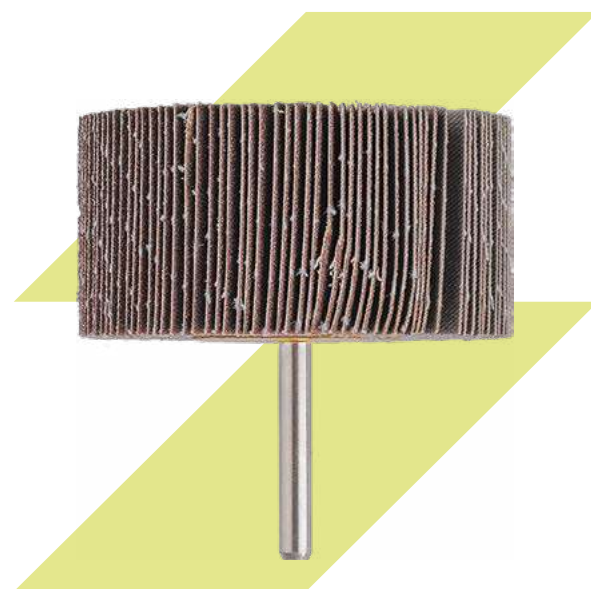

Круги лепестковые с оправкой КЛО КК19ХW

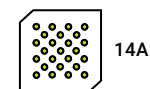

Артикул		D, мм	h, мм	D хвостовика, мм	Зернистость
1583588	○	30,0	30,0	6,0	P40
1583589	○	30,0	30,0	6,0	P60
1583590	○	40,0	30,0	6,0	P40
1583591	○	40,0	30,0	6,0	P60
1729336	○	60,0	20,0	6,0	16-H
1643010	○	60,0	20,0	6,0	P60
1729271	○	60,0	30,0	6,0	P60
1583592	○	60,0	50,0	6,0	P40
1643011	○	80,0	20,0	6,0	P60
1102369	○	80,0	30,0	6,0	6-H
1102366	○	80,0	30,0	6,0	10-H
1102367	○	80,0	30,0	6,0	12-H
1102368	○	80,0	30,0	6,0	16-H
1102370	○	80,0	30,0	6,0	M40
1729272	○	80,0	30,0	6,0	P60
1583593	○	80,0	40,0	6,0	P40
1643012	○	80,0	40,0	6,0	P60
1583594	○	80,0	50,0	6,0	P40
1583595	○	80,0	50,0	6,0	P60



Круги лепестковые КЛТ1 КК10ХW

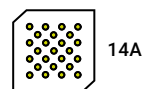

Артикул		D, мм	D посадочного отверстия, мм	Зернистость
1147800	●	115,0	22,0	P40
1147801	○	115,0	22,0	P60
1147802	○	115,0	22,0	P80
1147803	○	115,0	22,0	P120
1377050	○	125,0	22,0	P24
113181	●	125,0	22,0	P40
117688	●	125,0	22,0	P60
117443	●	125,0	22,0	P80
1276739	○	125,0	22,0	P100
1141117	●	125,0	22,0	P120
1276740	○	125,0	22,0	P180
1276741	○	125,0	22,0	P240
1289476	○	125,0	22,0	P320
1378171	○	150,0	22,0	P40
1326145	●	150,0	22,0	P60
1265232	○	150,0	22,0	P80
1325978	○	180,0	22,0	P24
1176085	●	180,0	22,0	P40
1276742	●	180,0	22,0	P60
1276743	●	180,0	22,0	P80
1325996	○	180,0	22,0	P100

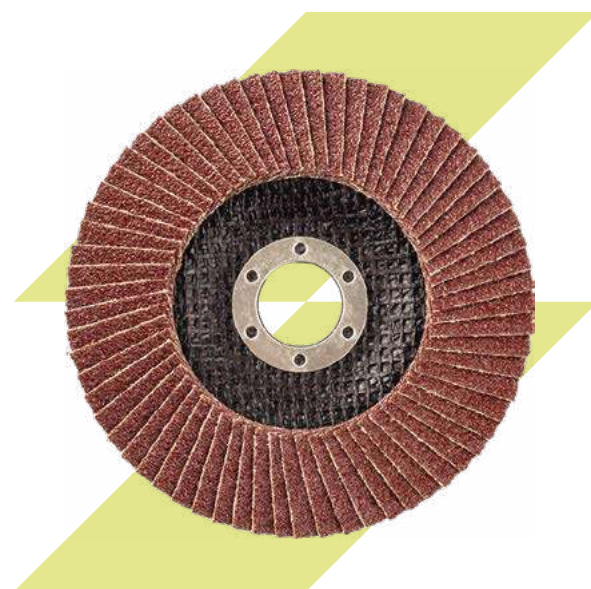

Ленты шлифовальные бесконечные ЗК10ХW



Артикул		b, мм	L, мм	Зернистость
1740104	○	6,0	305,0	P60
1740105	○	6,0	305,0	P80
1740106	○	6,0	305,0	P100
1477797	○	9,0	533,0	P60
1591782	○	9,0	533,0	P80
1591783	○	9,0	533,0	P100
1477798	○	20,0	520,0	P60
1740107	○	25,0	457,0	P60
1740108	○	25,0	457,0	P80
1740109	○	25,0	457,0	P100
1591784	○	30,0	533,0	P80
1591785	○	30,0	533,0	P100
1740110	○	40,0	815,0	P120

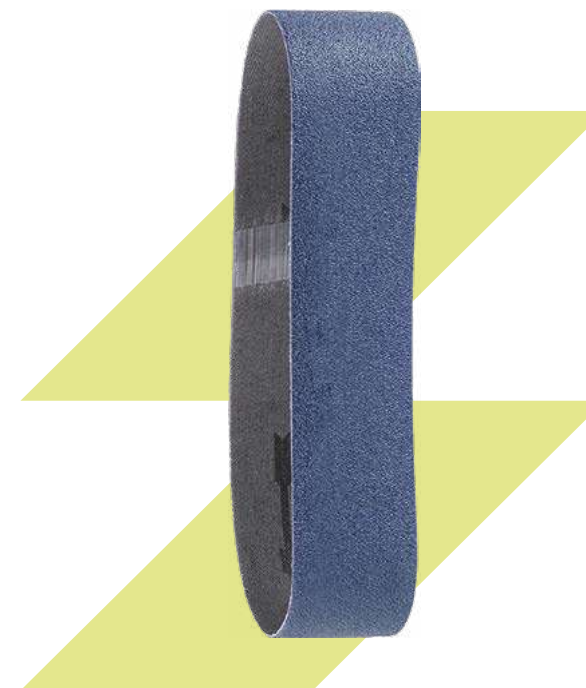

Ленты шлифовальные бесконечные



Бумажная



14A



Артикул		b, мм	L, мм	Зернистость
1226845	●	30,0	740,0	25-H
1185674	●	30,0	740,0	32-H
118877	●	75,0	457,0	P40
118878	●	75,0	457,0	P60
119001	●	75,0	457,0	P80
118879	●	75,0	457,0	P100
1736959	○	75,0	457,0	P120
1378676	○	75,0	457,0	P150
1181191	●	75,0	533,0	P40
1234548	●	75,0	533,0	P60
1134633	●	75,0	533,0	P80
1134634	●	75,0	533,0	P120
1134635	●	75,0	533,0	P180
1181192	○	100,0	610,0	P40
1425471	○	100,0	610,0	P60
1236251	○	100,0	610,0	P80
1181193	○	100,0	610,0	P100
1181194	○	100,0	610,0	P120
1185673	○	100,0	610,0	P180

Шлифовальные шкурки листовые СТЮСW



Бумажная



Водостойкая

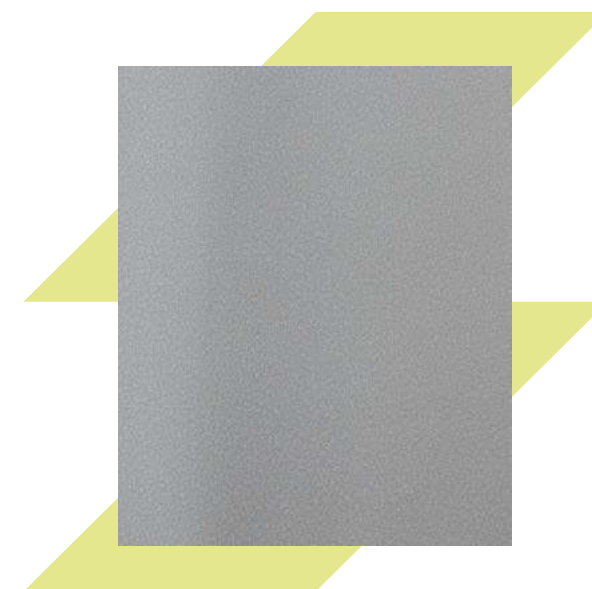

Артикул		b, мм	L, мм	Зернистость	Комплек- тация, шт
1583379	○	230,0	280,0	P60	50
1583380	○	230,0	280,0	P150	50
1583381	○	230,0	280,0	P180	50
1583382	○	230,0	280,0	P220	50
1583383	○	230,0	280,0	P240	50
1583384	○	230,0	280,0	P280	50
1583385	○	230,0	280,0	P320	50
1613396	○	230,0	280,0	P360	50
1583386	○	230,0	280,0	P400	50
1583387	○	230,0	280,0	P500	50
1583388	○	230,0	280,0	P600	50
1583389	○	230,0	280,0	P800	50
1583390	○	230,0	280,0	P1000	50
1583391	○	230,0	280,0	P1200	50
1583392	○	230,0	310,0	P1200	50
1583393	○	230,0	280,0	P1500	50
1583394	○	230,0	280,0	P2000	50
1583395	○	230,0	280,0	P2500	50

Шлифовальные шкурки листовые КТЮСW



Бумажная



Водостойкая

Артикул		б, мм	Л, мм	Зерни- стость	Комплек- тация, шт
1583283	○	230,0	280,0	P60	50
1583361	○	230,0	280,0	P80	50
1583362	○	230,0	280,0	P100	50
1583363	○	230,0	280,0	P120	50
1583364	○	230,0	280,0	P150	50
1583365	○	230,0	280,0	P180	50
1583366	○	230,0	280,0	P220	50
1583367	○	230,0	280,0	P240	50
1583368	○	230,0	280,0	P280	50
1583369	○	230,0	280,0	P320	50
1583370	○	230,0	280,0	P360	50
1583371	○	230,0	280,0	P400	50
1583372	○	230,0	280,0	P500	50
1583373	○	230,0	280,0	P600	50
1583374	○	230,0	280,0	P800	50
1583375	○	230,0	280,0	P1000	50
1583376	○	230,0	280,0	P1200	50
1583377	○	230,0	280,0	P1500	50
1583378	○	230,0	280,0	P2000	50

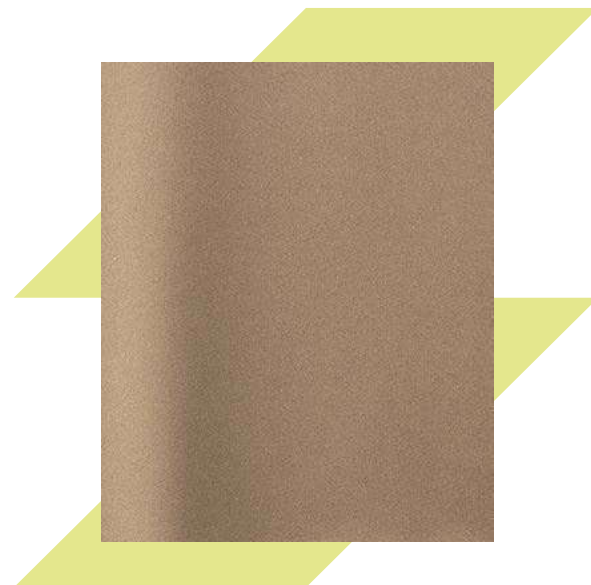

Шлифовальные шкурки листовые



Водостойкая

Артикул		б, мм	Л, мм	Зерни- стость	Комплек- тация, шт
1583396	○	170,0	240,0	4-H	10
1583397	○	170,0	240,0	5-H	10
1583398	○	170,0	240,0	6-H	10
1583399	○	170,0	240,0	8-H	10
1583400	○	170,0	240,0	10-H	10
1583401	○	170,0	240,0	12-H	10
1583402	○	170,0	240,0	16-H	10
1583403	○	170,0	240,0	20-H	10
1583404	○	170,0	240,0	25-H	10
1583405	○	170,0	240,0	32-H	10
1583406	○	170,0	240,0	40-H	10
1583407	○	170,0	240,0	50-H	10
1583408	○	170,0	240,0	63-H	10
1583409	○	170,0	240,0	M40	10

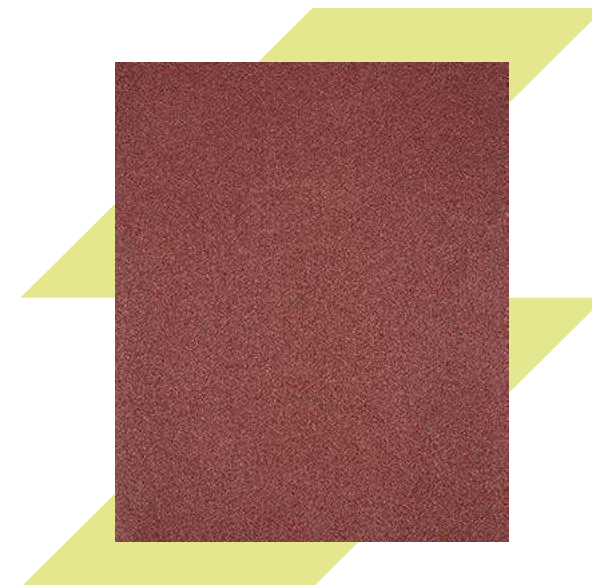

Шлифовальные шкурки рулонные КК19ХW



Тканевая



Водостойкая

Артикул		b, мм	L, мм	Зерни- стость	Комплек- тация, рулоны	Размер, м ²
1331129	○	775,0	30,0	4-Н	1	23,25
1614495	○	775,0	30,0	5-Н	1	23,25
1378668	○	775,0	30,0	6-Н	1	23,25
1582875	○	775,0	30,0	8-Н	1	23,25
1533149	○	775,0	30,0	10-Н	1	23,25
1378669	○	775,0	30,0	12-Н	1	23,25
1289521	○	775,0	30,0	16-Н	1	23,25
1582876	○	775,0	30,0	20-Н	1	23,25
1424896	○	775,0	30,0	25-Н	1	23,25
1377058	○	775,0	30,0	40-Н	1	23,25
1424870	○	775,0	30,0	50-Н	1	23,25
1251436	○	775,0	30,0	M40	1	23,25



Шлифовальные шкурки рулонные 14А СФЖ У1С



Тканевая



Водостойкая

Артикул		b, мм	L, мм	Зерни- стость	Комплек- тация, рулоны	Размер, м ²
1376967	○	800,0	30,0	2-Н	1	24,0
1477137	○	800,0	30,0	3-Н	1	24,0
1137860	●	800,0	30,0	4-Н	1	24,0
1137861	●	800,0	30,0	5-Н	1	24,0
1137572	●	800,0	30,0	6-Н	1	24,0
1149244	●	800,0	30,0	8-Н	1	24,0
1149245	●	800,0	30,0	10-Н	1	24,0
1137862	●	800,0	30,0	12-Н	1	24,0
1136125	●	800,0	30,0	16-Н	1	24,0
1137863	●	800,0	30,0	20-Н	1	24,0
1137573	●	800,0	30,0	25-Н	1	24,0
1137864	●	800,0	30,0	32-Н	1	24,0
1137574	●	800,0	30,0	40-Н	1	24,0
1253590	●	800,0	30,0	50-Н	1	24,0
1137571	●	800,0	30,0	M40	1	24,0



Круги отрезные 14А

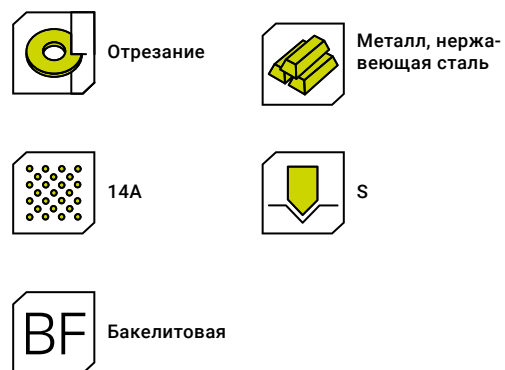

Артикул	D, мм	h, мм	D посадочно-го отверстия, мм	Зернистость
1424792	115,0	1,0	22,0	F54
112973	115,0	1,2	22,0	F54
1105301	115,0	1,6	22,0	F40
112974	115,0	2,5	22,0	F30
1260310	125,0	0,8	22,0	F60
1102841	125,0	1,0	22,0	F54
112975	125,0	1,2	22,0	F54
112976	125,0	1,6	22,0	F40
1183773	125,0	2,0	22,0	F36
112977	125,0	2,5	22,0	F30
1104309	125,0	3,0	22,0	F24
1416862	125,0	3,0	32,0	F24
1178869	150,0	1,0	22,0	F54
1326020	150,0	1,2	22,0	F54
1102685	150,0	1,6	22,0	F40
1289632	150,0	2,0	22,0	F36
1343032	150,0	2,0	32,0	F36
112978	150,0	2,5	22,0	F30
1102386	150,0	3,0	22,0	F24
1331117	180,0	1,4	22,0	F40
118767	180,0	1,6	22,0	F40
1289368	180,0	2,0	22,0	F36
112979	180,0	2,5	22,0	F30
1150296	180,0	2,5	32,0	F30
112980	180,0	3,0	22,0	F24
1149610	230,0	1,6	22,0	F40
1345721	230,0	1,8	22,0	F40
112986	230,0	2,0	22,0	F36
112987	230,0	2,5	22,0	F30
112988	230,0	2,5	32,0	F30
112989	230,0	3,0	22,0	F24
1103308	230,0	3,0	32,0	F24
112990	300,0	3,0	32,0	F24
112991	355,0	3,5	25,4	F24
1293021	400,0	3,0	32,0	F24
112992	400,0	4,0	32,0	F24



Круги зачистные 14А

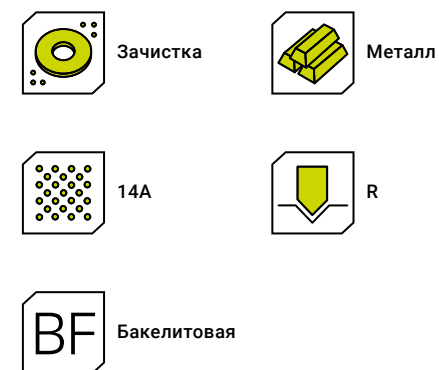

Артикул	D, мм	h, мм	D посадочно-го отверстия, мм	Зернистость
112961	115,0	6,0	22,0	F24
112962	125,0	6,0	22,0	F24
112963	150,0	6,0	22,0	F24
112964	180,0	6,0	22,0	F24
112966	230,0	6,0	22,0	F24



Круги вулканические отрезные

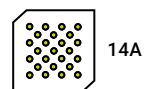

Артикул	D, мм	h, мм	D посадочного отверстия, мм	Зернистость	Твердость
1226868	150,0	0,5	32,0	F90	O
1185677	150,0	0,6	32,0	F60	O
1109362	150,0	0,8	32,0	F60	O
1226869	150,0	1,0	32,0	F60	O
1326065	150,0	1,0	32,0	F90	P
1185678	150,0	1,2	32,0	F60	O
1271873	150,0	1,4	32,0	F60	O
1226870	150,0	1,4	32,0	F90	O
1271877	150,0	1,6	32,0	F60	O
1185679	150,0	1,6	32,0	F90	O
1271874	150,0	1,8	32,0	F60	O
1185680	150,0	1,8	32,0	F90	O
1642996	150,0	2,0	32,0	F46	O
1252633	150,0	2,0	32,0	F60	O
1335728	175,0	0,6	32,0	F46	O
1271875	175,0	0,6	32,0	F60	O
1177584	175,0	0,6	32,0	F90	O
1150265	175,0	0,8	32,0	F90	O
1271913	175,0	1,0	32,0	F60	O
1109810	175,0	1,0	32,0	F90	O
1271914	175,0	1,6	32,0	F60	O
1109363	175,0	1,6	32,0	F90	O
1271876	175,0	2,0	32,0	F60	O
1109364	175,0	2,0	32,0	F90	O
1425308	175,0	4,0	32,0	F60	O
1583214	200,0	1,0	32,0	F60	O
1104663	200,0	1,0	32,0	F90	O
1379287	200,0	1,2	32,0	F90	S
1286946	200,0	1,5	32,0	F60	P
1286947	200,0	1,5	32,0	F90	P
1107727	200,0	1,6	32,0	F90	O
1418349	200,0	1,6	32,0	F90	P
1286951	200,0	1,8	32,0	F90	P
1583215	200,0	2,0	32,0	F60	O
1109811	200,0	2,0	32,0	F90	O



Круги вулканические полировальные

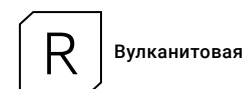
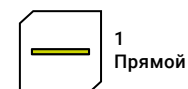
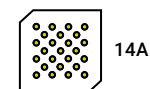

Артикул	D, мм	h, мм	D посадочного отверстия, мм	Зернистость	Твердость
1634396	100,0	6,0	20,0	F90	ГТ
1729418	100,0	6,0	20,0	F90	ГС
1634395	100,0	10,0	20,0	F90	ГТ
1729419	100,0	10,0	20,0	F90	ГС
1425305	100,0	20,0	20,0	F60	ГС
1139916	150,0	10,0	32,0	F90	ГС
1137613	150,0	13,0	32,0	F90	ГМ
1175599	150,0	16,0	32,0	F70	ГМ
1425306	150,0	20,0	32,0	F60	ГМ
1425307	150,0	20,0	32,0	F60	ГС
1227124	150,0	20,0	32,0	F70	ГМ
1612814	150,0	20,0	32,0	F90	ГС
1273124	175,0	10,0	32,0	F60	ГС
1262833	175,0	20,0	32,0	F60	ГС
1252237	175,0	20,0	32,0	F90	ГС
1518391	200,0	10,0	32,0	F70	ГС
1104398	200,0	20,0	32,0	F60	ГМ
1258394	200,0	20,0	32,0	F60	ГС
1518392	200,0	20,0	32,0	F70	ГС
1480648	300,0	40,0	127,0	F90	ГМ

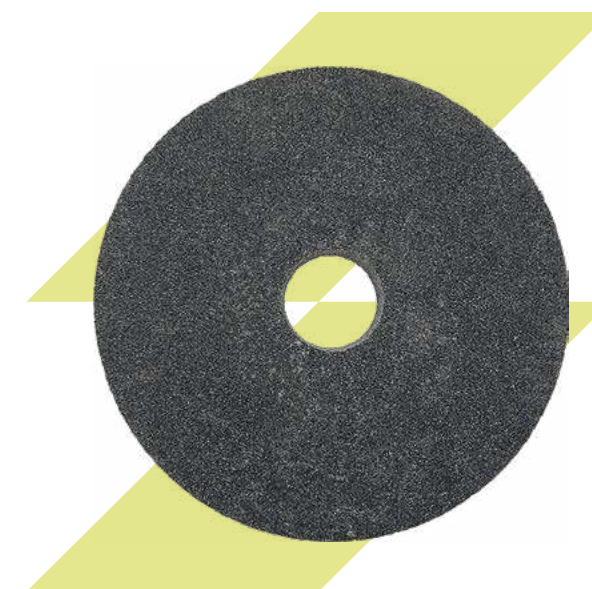

Шлифовальный материал



Шлифование



Артикул	 Единицы измерения	Тип зерна	Зернистость
1583227	т	14A	F20
1379470	т	14A	F46
1379471	т	14A	F80
1379472	т	14A	F100
1379473	т	14A	F150
1379474	т	14A	F180
1379475	т	14A	F320
1379476	т	14A	F600
1584261	т	25A	F16
1379477	т	25A	F24
1379478	т	25A	F30
1584262	т	25A	F36
1379479	т	25A	F40
1379480	т	25A	F46
1379430	т	25A	F54
1379431	т	25A	F60
1416730	т	25A	F70
1379481	т	25A	F100
1379482	т	25A	F120
1379432	т	25A	F150
1379433	т	25A	F180
1379483	т	25A	F220
1584263	т	25A	F240
1379434	т	25A	F320
1379435	т	25A	F360
1379484	т	25A	F400
1379486	т	25A	F800

Для заметок

Area for notes with horizontal dashed lines.

Алмазный инструмент

Инструмент для шлифовальных работ	933
Головки алмазные шлифовальные	933
Круги алмазные	938
Пасты полировальные	949
Инструмент для ручных работ	951
Бруски	951
Надфили	953
Инструмент для резки материалов	961
Круги алмазные отрезные	961
Инструмент правящий	964
Алмазы в оправе	964
Иглы алмазные	966
Карандаши алмазные	967

Инструмент алмазный для шлифовальных работ

Инструмент для шлифовальных работ используется на электронных шлифовальных машинах, портальных шлифовальных машинах и ручных дрелях. Применяется для шлифовки керамики, стекла, драгоценных камней, сплавов и многих других абразивных материалов. Защищает поверхность от механических повреждений, исправляет косметические дефекты и придает поверхности зеркальный блеск.

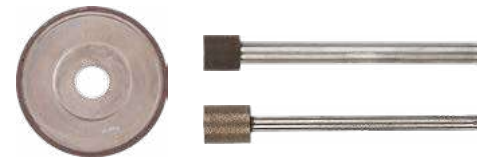

Инструмент алмазный для ручных работ

Инструмент для ручных работ предназначен для заточки особо твердого инструмента, ножей, ножниц, топоров, стамесок, фрез, также используется для быстрорежущих сталей и неметаллических материалов (стекло, керамика). Используется при слесарных работах и мелком ремонте для опиления и подгонки металлических деталей, зачистке клемм, обработке небольших отверстий или мелких пазов. Изготовлен из монокристаллических алмазов, что обеспечивает твердость и износостойкость инструмента. Имеет покрытие из порошка технических алмазов.



Инструмент алмазный для резки материалов

Алмазные отрезные круги являются сменными элементами для угловых шлифовальных машин. Изготавливаются с использованием электротехнологий и порошковой металлургии и предназначены для резки природных и синтетических поделочных камней, мрамора, гранита, корунда, шамотного кирпича, песчаника.



Инструмент алмазный правящий

Инструмент алмазный правящий применяется для правки (устранения сколов и других дефектов) шлифовальных кругов с целью обеспечения высокой точности рабочей поверхности круга. Правка производится как на операциях наружного, внутреннего, круглого, бесцентрового и плоского шлифования, так и на отдельных операциях резьбошлифования, зубошлифования, шлищешлифования и других операциях финишной обработки фасонных поверхностей.



Условные обозначения

Форма

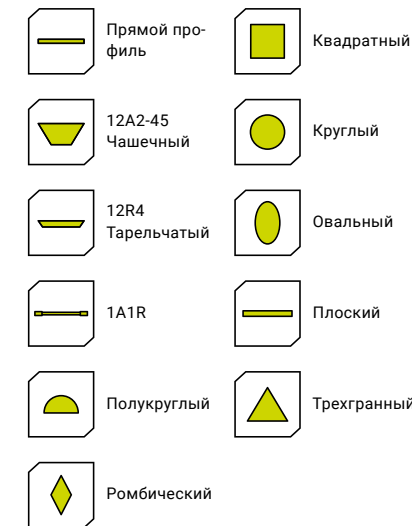

Форма

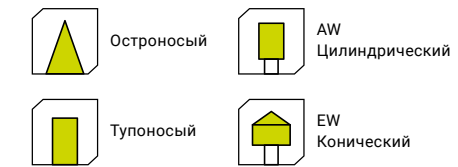

Связка

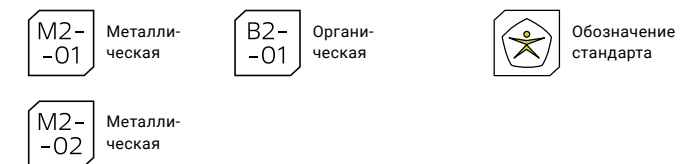

Наличие инструмента

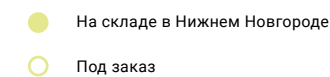

Инструмент для шлифовальных работ

	Головки алмазные шлифовальные		
Форма	EW (коническая)	AW (цилиндрическая)	AW (цилиндрическая)
Тип	ГОСТ 17122-85	ГОСТ 17122-85	ГОСТ 17122-85
Связка	—	B2-01	M2-01
Страница	933	934	936



	Круги алмазные				Пасты полировальные
Стандарт	ГОСТ Р 53923-2010	ГОСТ Р 53923-2010	ГОСТ Р 53923-2010	ГОСТ Р 53923-2010	ГОСТ 25593-83
Тип	—	—	—	—	—
Связка	B2-01	B2-01	B2-01	B2-01	—
Форма	12R4 (тарельчатый)	12A2-20 (тарельчатый)	12A2-45 (чашечный)	1A1 (прямой профиль)	—
Страница	938	940	942	945	949



Инструмент для ручных работ

	Бруски алмазные	Надфили алмазные							
Тип	—	Остроносый	Остроносый	Остроносый	Остроносый	Тупоносый	Остроносый	Тупоносый	Равнобедренный
Стандарт	ГОСТ 25594-83	ГОСТ 23461-84	ГОСТ 23461-84	ГОСТ 23461-84	ГОСТ 23461-84	ГОСТ 23461-84	ГОСТ 23461-84	ГОСТ 23461-84	ГОСТ 23461-84
Форма	—	Квадратный	Круглый	Овальный	Плоский	Плоский	Полукруглый	Ромбический	Трехгранный
Страница	951	953	954	955	956	957	958	959	960



Инструмент для резки материалов

	Круги алмазные отрезные	
Стандарт	ГОСТ 32833-2014	ГОСТ 32833-2014
Форма	1A1R	1A1R
Связка	M2-02	M2-01
Страница	961	961



Инструмент правящий

	Алмазы в оправе	Иглы алмазные	Карандаши алмазные
Стандарт	ГОСТ 22908-78	ГОСТ 17564-85	ГОСТ 607-80
Страница	964	966	967
			

Головки алмазные шлифовальные конические









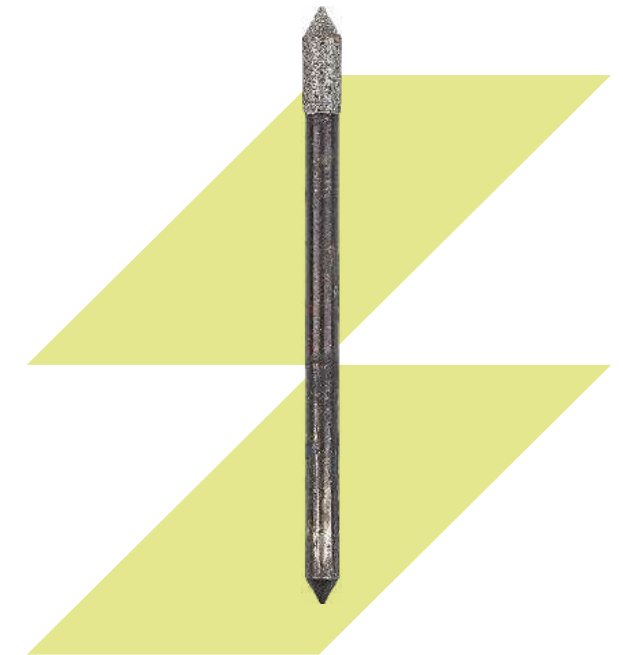



ГОСТ 17122-85



EW
Конический



Артикул		D, мм	h, мм	d, мм	L, мм
1243016		1,0	8,0	3,0	40
100001		1,2	8,0	8,0	52
100003		1,6	8,0	3,0	43
100004		1,8	8,0	8,0	43
100005		2,1	10,0	6,0	56
100006		2,3	10,0	8,0	54
1243014		2,6	10,0	3,0	56
1243015		2,8	10,0	3,0	56
100007		3,2	10,0	3,0	56
100008		3,5	10,0	3,0	56

Головки алмазные шлифовальные цилиндрические В2-01

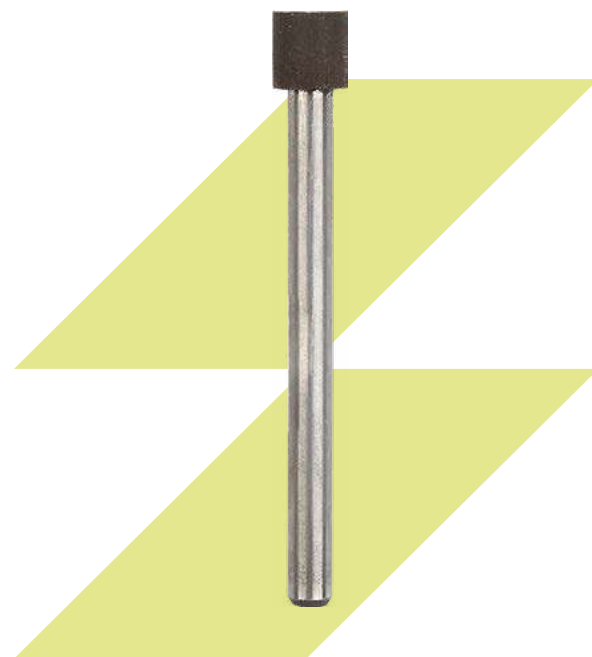

Артикул		D, мм	h, мм	d, мм	L, мм	Марка порошка	Зернистость	Концентрация алмазов	Связка	Масса, караты
1269745	○	0,8	7,0	3,0	50,0	AC20	80/63	100%	B2-01	0,13
1269746	○	1,2	7,0	3,0	50,0	AC20	80/63	100%	B2-01	0,13
1418625	○	1,2	7,0	3,0	50,0	AC20	160/125	100%	B2-01	—
1418626	○	1,5	6,0	3,0	35,0	AC20	160/125	100%	B2-01	—
1269747	○	1,6	6,0	3,0	35,0	AC20	80/63	100%	B2-01	0,13
1269748	○	2,0	7,0	3,0	50,0	AC20	80/63	100%	B2-01	0,13
1418627	○	2,0	7,0	3,0	50,0	AC20	160/125	100%	B2-01	—
1269760	○	2,5	7,0	3,0	50,0	AC20	80/63	100%	B2-01	0,13
1634378	○	2,5	7,0	3,0	50,0	AC20	100/80	100%	B2-01	—
1418628	○	2,5	7,0	3,0	50,0	AC20	160/125	100%	B2-01	—
1103497	○	3,0	6,0	3,0	40,0	AC2C	125/100	100%	B2-01	0,13
100010	○	3,0	6,0	3,0	40,0	AC5C	63/50	100%	B2-01	0,13

Артикул		D, мм	h, мм	d, мм	L, мм	Марка порошка	Зернистость	Концентрация алмазов	Связка	Масса, караты
1243017	○	3,0	6,0	3,0	40,0	ACM	60/40	100%	B2-01	0,13
1441277	○	4,0	6,0	3,0	40,0	ACM	14/10	100%	B2-01	0,30
1441278	○	4,0	6,0	3,0	40,0	ACM	28/20	100%	B2-01	0,30
1441279	○	4,0	6,0	3,0	40,0	ACM	5/3	100%	B2-01	0,30
1441280	○	4,0	6,0	3,0	40,0	ACM	7/5	100%	B2-01	0,30
1103498	○	4,0	6,0	4,0	40,0	AC2C	160/125	100%	B2-01	0,27
1634380	○	4,0	7,0	3,0	50,0	AC20	100/80	100%	B2-01	—
1419550	○	5,0	7,0	3,0	50,0	AC20	125/100	100%	B2-01	—
1335538	○	5,0	7,0	3,0	60,0	AC20	80/63	100%	B2-01	—
1418630	○	5,0	7,0	3,0	60,0	AC20	160/125	100%	B2-01	—
1335539	○	6,0	7,0	3,0	60,0	AC20	80/63	100%	B2-01	—
1614331	○	6,0	8,0	3,0	60,0	AC20	63/50	100%	M2-01	—
1583163	○	6,0	8,0	6,0	90,0	AC6	80/63	100%	B2-01	0,54
1583164	○	8,0	7,0	8,0	90,0	AC6	80/63	100%	B2-01	0,90
1183585	○	8,0	8,0	3,0	60,0	AC4	63/50	100%	B2-01	—
1103504	○	8,0	10,0	3,0	60,0	AC2	160/125	100%	B2-01	1,96
1243020	○	8,0	10,0	3,0	60,0	AC2C	160/125	100%	B2-01	1,96
1103506	○	8,0	10,0	3,0	60,0	ACM	60/40	100%	B2-01	1,96
1183586	○	10,0	10,0	6,0	80,0	AC4	50/40	100%	B2-01	—
1183588	○	10,0	10,0	6,0	80,0	AC4	63/50	100%	B2-01	—
1183589	○	10,0	10,0	6,0	80,0	AC4	125/100	100%	B2-01	—
1184120	○	10,0	10,0	6,0	80,0	AC6	50/40	100%	B2-01	—
1183587	○	12,0	12,0	6,0	80,0	AC4	63/50	100%	B2-01	—
1183591	○	12,0	12,0	6,0	80,0	AC4	80/63	100%	B2-01	—
1183592	○	12,0	12,0	6,0	80,0	AC4	160/125	100%	B2-01	—
1183590	○	12,0	12,0	6,0	80,0	AC6	50/40	100%	B2-01	—

Головки алмазные шлифовальные цилиндрические M2-01

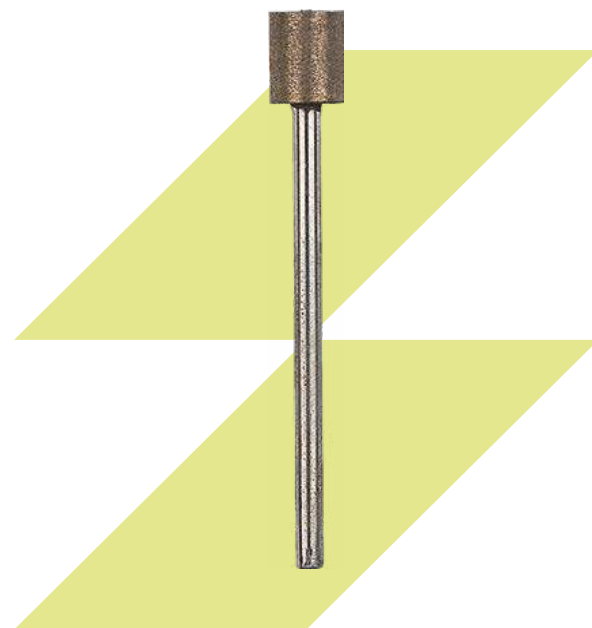

Артикул		D, мм	h, мм	d, мм	L, мм	Марка порошка	Зернистость	Концентрация алмазов	Связка	Масса, караты
1103507		10,0	16,0	6,0	60,0	AC4	160/125	100%	M2-01	3,90
1260301		10,0	16,0	6,0	60,0	AC6	63/50	100%	M2-01	3,90
1171092		10,0	16,0	6,0	80,0	AC6	63/50	100%	M2-01	3,90
1103510		12,0	16,0	6,0	80,0	AC6	63/50	100%	M2-01	6,30

Артикул		D, мм	h, мм	d, мм	L, мм	Марка порошка	Зернистость	Концентрация алмазов	Связка	Масса, караты
100009		3,0	6,0	3,0	40,0	AC4	63/50	100%	M2-01	0,13
1103577		3,0	6,0	3,0	40,0	ACM	60/40	100%	M2-01	0,13
1103499		4,0	6,0	4,0	40,0	AC4	100/80	100%	M2-01	0,27
100011		4,0	6,0	4,0	40,0	AC4	160/125	—	M2-01	0,27
1243018		4,0	6,0	4,0	40,0	AC6	160/125	—	M2-01	0,27
1614330		4,0	8,0	3,0	60,0	AC20	63/50	100%	M2-01	—
1614331		6,0	8,0	3,0	60,0	AC20	63/50	100%	M2-01	—
1103502		6,0	10,0	3,0	60,0	AC4	100/80	100%	M2-01	1,00
1243013		6,0	10,0	3,0	60,0	AC6	63/50	100%	M2-01	1,00
1243019		6,0	10,0	5,0	60,0	AC4	100/80	100%	M2-01	1,00
1103505		8,0	10,0	3,0	60,0	AC4	100/80	100%	M2-01	1,96
1260302		8,0	10,0	6,0	60,0	AC6	63/50	100%	M2-01	1,96

Круги алмазные шлифовальные 12R4



ГОСТ 3749-77



12R4
Тарельчатый



B2-01
Органическая



Артикул		D, мм	Ширина алмазного слоя	Толщина алмазного слоя	h, мм	d посадочного отверстия, мм	Марка порошка	Зернистость	Концентрация алмазов	Масса алмазов, караты
1253297		125,0	3	2	13,0	32,0	AC6	125/100	100%	12,0
1425324		125,0	3	2	13,0	32,0	AC6	160/125	100%	12,0
1105628		150,0	5	3	16,0	32,0	AC4	80/63	100%	12,0
118165		150,0	5	3	16,0	32,0	AC4	100/80	100%	35,4
119233		150,0	5	3	16,0	32,0	AC4	125/100	100%	35,4
117960		150,0	5	3	16,0	32,0	AC4	160/125	100%	35,4
1253296		150,0	5	3	16,0	32,0	AC6	125/100	100%	35,4

Артикул		D, мм	Ширина алмазного слоя	Толщина алмазного слоя	h, мм	d посадочного отверстия, мм	Марка порошка	Зернистость	Концентрация алмазов	Масса алмазов, караты
1171164		75,0	3	2	10,0	16,0	AC4	125/100	100%	6,9
102237		75,0	3	2	10,0	20,0	AC2	80/63	100%	6,4
1171163		75,0	3	2	10,0	20,0	AC4	80/63	100%	6,9
1171165		75,0	3	2	10,0	20,0	AC4	100/80	100%	6,9
1614305		75,0	3	2	10,0	20,0	AC4	125/100	100%	6,9
1425196		75,0	3	2	10,0	20,0	AC6	100/80	100%	6,9
1238277		75,0	3	2	10,0	20,0	AC6	125/100	100%	6,5
1425197		100,0	3	2	10,0	32,0	AC6	100/80	100%	9,5
1269442		100,0	3	2	10,0	32,0	AC6	125/100	100%	9,5
1260343		125,0	3	2	13,0	32,0	AC4	80/63	100%	12,0
1109793		125,0	3	2	13,0	32,0	AC4	100/80	100%	12,0
1242794		125,0	3	2	13,0	32,0	AC4	125/100	100%	12,0

Круги алмазные шлифовальные 12A2-20

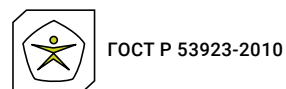

Артикул		D, мм	Ширина алмазного слоя	Толщина алмазного слоя	h, мм	d посадочного отверстия, мм	Марка порошка	Зернистость	Концентрация алмазов	Масса алмазов, караты
1425331		125,0	6	2	16,0	32,0	AC4	160/125	100%	19,7
1583210		125,0	10	2	16,0	32,0	AC4	80/63	100%	32,0
118238		125,0	10	2	16,0	32,0	AC4	100/80	100%	32,0
1102873		125,0	10	2	16,0	32,0	AC4	125/100	100%	32,0
1276694		150,0	3	2	18,0	32,0	AC4	100/80	100%	12,2
1417356		150,0	6	2	18,0	32,0	AC4	100/80	100%	23,9
1135420		150,0	6	2	18,0	32,0	AC4	125/100	100%	23,9
1135421		150,0	6	2	18,0	32,0	AC4	160/125	100%	23,9
1264188		150,0	6	2	18,0	32,0	AC6	125/100	100%	23,9
1185681		150,0	10	2	16,0	32,0	AC4	100/80	100%	58,0
1238278		150,0	10	2	18,0	32,0	AC4	100/80	100%	39,0
1258385		150,0	10	2	18,0	32,0	AC6	160/125	100%	39,0
1238279		150,0	18	2	6,0	32,0	AC4	125/100	100%	23,0
1425334		150,0	18	2	10,0	32,0	AC4	63/50	100%	—
1424938		200,0	10	2	22,0	32,0	AC4	100/80	100%	53,0

Артикул		D, мм	Ширина алмазного слоя	Толщина алмазного слоя	h, мм	d посадочного отверстия, мм	Марка порошка	Зернистость	Концентрация алмазов	Масса алмазов, караты
1441705		75,0	3	2	10,0	16,0	AC4	125/100	100%	6,0
1276692		75,0	3	2	10,0	20,0	AC4	100/80	100%	6,0
1614306		75,0	3	2	10,0	20,0	AC6	100/80	100%	6,0
1425326		75,0	5	2	10,0	16,0	AC6	63/50	100%	9,7
1260342		75,0	6	2	8,0	16,0	AC4	100/80	100%	5,8
1614307		75,0	6	2	10,0	20,0	ACH	40/28	100%	11,4
1260338		100,0	3	2	10,0	20,0	AC4	100/80	100%	—
1425330		100,0	6	2	12,0	20,0	AC4	125/100	100%	—
1171166		100,0	6	2	12,0	20,0	AC4	160/125	100%	15,6
1276693		125,0	3	2	16,0	32,0	AC4	100/80	100%	10,1
1102492		125,0	6	2	16,0	32,0	AC4	100/80	100%	19,7
118919		125,0	6	2	16,0	32,0	AC4	125/100	100%	19,7

Круги алмазные шлифовальные 12A2-45

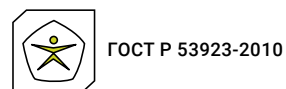

Артикул		D, мм	Ширина алмазного слоя	Толщина алмазного слоя	h, мм	d посадочного отверстия, мм	Марка порошка	Зернистость	Концентрация алмазов	Масса алмазов, караты
1273111	○	50,0	3	3	21,0	16,0	AC4	80/63	100%	5,8
1135004	○	50,0	3	3	21,0	16,0	AC4	100/80	100%	5,8
1273112	○	50,0	3	3	21,0	16,0	AC4	125/100	100%	5,8
102245	○	50,0	3	3	21,0	16,0	AC4	160/125	100%	5,8
1326077	○	75,0	3	3	21,0	20,0	AC4	63/50	100%	9,0
1260336	○	75,0	3	3	21,0	20,0	AC4	100/80	100%	5,8
1533075	○	75,0	6	3	21,0	16,0	AC4	125/100	100%	17,2
1425327	○	75,0	6	3	21,0	16,0	AC4	160/125	100%	17,2
1293036	○	75,0	6	3	21,0	16,0	AC6	50/40	100%	17,2
1530955	○	75,0	6	3	21,0	20,0	AC4	40/28	100%	17,2
1276691	○	75,0	6	3	21,0	20,0	AC4	80/63	100%	17,2
1276690	○	75,0	6	3	21,0	20,0	AC4	100/80	100%	17,2

Артикул		D, мм	Ширина алмазного слоя	Толщина алмазного слоя	h, мм	d посадочного отверстия, мм	Марка порошка	Зернистость	Концентрация алмазов	Масса алмазов, караты
1260337	○	75,0	6	3	21,0	20,0	AC4	100/80	100%	5,8
1530956	○	75,0	6	3	21,0	20,0	AC4	125/100	100%	17,2
1657312	○	75,0	6	3	21,0	20,0	AC6	80/63	100%	17,2
1657313	○	75,0	6	3	21,0	20,0	AC6	125/100	100%	17,2
1533076	○	75,0	6	3	21,0	20,0	ACH	40/28	100%	17,2
1425329	○	80,0	5	3	26,5	20,0	AC4	80/63	100%	—
1425328	○	80,0	5	3	26,5	20,0	AC4	125/100	100%	—
1425238	○	100,0	3	3	32,0	20,0	AC4	80/63	100%	—
1419440	○	100,0	6	3	32,0	32,0	AC4	100/80	100%	23,4
1269445	○	100,0	10	3	32,0	20,0	AC4	80/63	100%	37,0
1590949	○	100,0	10	3	32,0	20,0	AC6	125/100	100%	37,0
1590950	○	100,0	10	3	32,0	20,0	AC6	160/125	100%	37,0
1135005	○	125,0	3	3	40,0	32,0	AC4	100/80	100%	15,2
1425756	○	125,0	3	3	40,0	32,0	AC4	125/100	100%	—
1478454	○	125,0	3	3	40,0	32,0	AC6	80/63	100%	15,2
1424936	○	125,0	6	3	40,0	32,0	AC6	80/63	100%	29,6
1583508	○	125,0	10	3	40,0	32,0	AC4	63/50	100%	48,0
1257463	●	125,0	10	3	40,0	32,0	AC4	80/63	100%	48,0
1109794	●	125,0	10	3	40,0	32,0	AC4	100/80	100%	48,0
1171667	●	125,0	10	3	40,0	32,0	AC4	125/100	100%	48,0
1584896	○	125,0	10	3	40,0	32,0	AC4	160/125	100%	48,0
1110983	○	125,0	10	5	42,0	32,0	AC4	100/80	100%	80,0
1591692	○	125,0	10	5	42,0	32,0	AC4	125/100	100%	80,0
1582761	○	150,0	5	3	26,0	32,0	AC4	100/80	100%	30,0
1424937	○	150,0	5	3	26,0	32,0	AC6	80/63	100%	30,0
1130086	○	150,0	5	5	28,0	32,0	AC4	160/125	100%	52,4
1479532	○	150,0	10	3	40,0	32,0	AC4	80/63	100%	58,0
1171668	●	150,0	10	3	40,0	32,0	AC4	100/80	100%	58,0
102251	●	150,0	10	3	40,0	32,0	AC4	125/100	100%	58,0
1171669	●	150,0	10	3	40,0	32,0	AC4	160/125	100%	58,0
1424716	○	150,0	10	3	40,0	32,0	AC4	200/160	100%	58,0
1582115	○	150,0	10	5	42,0	32,0	AC4	80/63	100%	97,0
118016	●	150,0	10	5	42,0	32,0	AC4	100/80	100%	97,0
1129706	●	150,0	10	5	42,0	32,0	AC4	125/100	100%	97,0
1171670	●	150,0	10	5	42,0	32,0	AC4	160/125	100%	97,0
1105582	○	150,0	20	3	40,0	32,0	AC4	80/63	100%	108,0
102253	●	150,0	20	3	40,0	32,0	AC4	100/80	100%	108,0
102254	●	150,0	20	3	40,0	32,0	AC4	125/100	100%	108,0
1110902	●	150,0	20	3	40,0	32,0	AC4	160/125	100%	108,0

Артикул		D, мм	Ширина алмазного слоя	Толщина алмазного слоя	h, мм	d посадочного отверстия, мм	Марка порошка	Зернистость	Концентрация алмазов	Масса алмазов, караты
1740314	○	150,0	20	3	40,0	32,0	AC4	200/160	100%	108,0
1718450	○	150,0	20	3	40,0	32,0	AC6	100/80	100%	108,0
1260339	○	150,0	20	5	42,0	32,0	AC4	63/40	100%	180,0
1425335	○	150,0	20	5	42,0	32,0	AC4	63/50	100%	—
1240750	○	150,0	20	5	42,0	32,0	AC4	80/63	100%	180,0
1262983	●	150,0	20	5	42,0	32,0	AC4	100/80	100%	180,0
1377147	●	150,0	20	5	42,0	32,0	AC4	125/100	100%	180,0
1582825	○	150,0	20	5	42,0	32,0	AC4	160/125	100%	180,0
1292767	○	150,0	20	5	42,0	32,0	AC4	200/160	100%	180,0
1135557	○	150,0	20	5	42,0	32,0	AC6	80/63	100%	180,0
1269443	○	150,0	20	5	42,0	32,0	AC6	100/80	100%	180,0
1479913	○	150,0	20	5	42,0	32,0	AC6	160/125	100%	180,0
1269444	○	150,0	20	5	42,0	32,0	AC6	250/200	100%	180,0
1260340	○	200,0	10	3	50,0	51,0	AC4	100/80	100%	149,0
1260341	○	200,0	10	3	50,0	51,0	AC4	125/100	100%	149,0
1424587	○	200,0	10	3	50,0	51,0	AC4	160/125	100%	—
1424939	○	200,0	10	5	52,0	32,0	AC4	125/100	100%	132,0
1284351	○	200,0	10	5	52,0	32,0	ACH	14/10	100%	—
1265666	○	200,0	20	3	50,0	32,0	AC4	100/80	100%	149,0
1242897	○	200,0	20	3	50,0	51,0	AC4	125/100	100%	149,0
1260772	●	200,0	20	5	52,0	32,0	AC4	100/80	100%	249,0
1258986	○	200,0	20	5	52,0	32,0	AC6	100/80	100%	249,0
1585366	○	200,0	20	5	52,0	51,0	AC4	100/80	100%	249,0
1417685	●	200,0	20	5	52,0	76,0	AC4	100/80	100%	249,0
1293032	○	200,0	20	5	52,0	76,0	AC6	100/80	100%	249,0

Круги алмазные шлифовальные 1A1

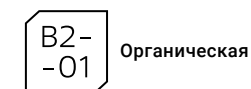
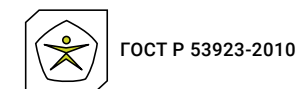

Артикул		D, мм	Толщина алмазного слоя	h, мм	d посадочного отверстия, мм	Марка порошка	Зернистость	Концентрация алмазов	Масса алмазов, караты
1273099	○	63,0	3	10,0	20,0	AC4	125/100	100%	25,0
1377613	○	63,0	3	10,0	20,0	AC6	100/80	100%	25,0
1614309	○	80,0	3	6,0	20,0	ACH	28/20	100%	19,2
1260345	○	80,0	5	6,0	20,0	AC4	100/80	100%	66,0
1591740	○	80,0	5	6,0	20,0	AC4	125/100	100%	—
1477424	○	80,0	3	10,0	20,0	ACM	40/28	100%	—
1584624	○	80,0	3	10,0	20,0	ACH	40/28	100%	32,0
1582594	○	80,0	3	10,0	20,0	AC4	125/100	100%	—
1425336	○	80,0	5	10,0	20,0	AC6	80/63	100%	—
1326526	○	80,0	3	20,0	20,0	AC4	125/100	100%	64,0
119426	○	100,0	3	8,0	20,0	AC4	100/80	100%	32,0
1337730	○	100,0	3	10,0	20,0	AC4	125/100	100%	—

Артикул		D, мм	Толщина алмазного слоя	h, мм	d посадочного отверстия, мм	Марка порошка	Зернистость	Концентрация алмазов	Масса алмазов, караты
1103094	○	100,0	5	10,0	20,0	AC4	100/80	100%	66,0
1141282	○	100,0	5	10,0	20,0	AC4	125/100	100%	—
1260346	○	100,0	5	20,0	20,0	AC4	100/80	100%	—
1289347	○	100,0	5	20,0	20,0	AC4	160/125	100%	—
1441695	○	125,0	3	6,0	32,0	AC4	80/63	100%	30,0
1441576	○	125,0	3	6,0	32,0	AC4	125/100	100%	—
1441709	○	125,0	3	6,0	32,0	AC4	160/125	100%	30,0
118235	●	125,0	3	10,0	32,0	AC4	100/80	100%	51,0
118795	●	125,0	3	10,0	32,0	AC4	125/100	100%	51,0
1271985	○	125,0	5	10,0	32,0	AC4	80/63	100%	83,0
1102869	○	125,0	5	10,0	32,0	AC4	100/80	100%	83,0
1104880	●	125,0	5	10,0	32,0	AC4	125/100	100%	83,0
1108786	○	125,0	5	10,0	32,0	AC4	160/125	100%	83,0
1477425	○	125,0	3	20,0	32,0	AC4	125/100	100%	—
1584302	○	125,0	5	20,0	32,0	AC4	125/100	100%	166,0
1612988	○	125,0	5	20,0	32,0	AC4	160/125	100%	166,0
1479552	○	150,0	3	6,0	32,0	AC4	125/100	100%	37,0
1441781	○	150,0	3	6,0	32,0	AC4	160/125	100%	37,0
1479533	○	150,0	3	6,0	32,0	AC4	200/160	100%	37,0
102274	○	150,0	3	6,0	32,0	AC6	125/100	100%	37,0
1425239	○	150,0	5	6,0	32,0	AC4	80/63	100%	—
1441782	○	150,0	5	8,0	32,0	AC4	160/125	100%	80,0
1584164	○	150,0	3	10,0	32,0	AC4	50/40	100%	61,0
1141764	○	150,0	3	10,0	32,0	AC4	80/63	100%	61,0
118794	●	150,0	3	10,0	32,0	AC4	100/80	100%	61,0
118166	●	150,0	3	10,0	32,0	AC4	125/100	100%	61,0
1141765	●	150,0	3	10,0	32,0	AC4	160/125	100%	61,0
1591586	○	150,0	3	10,0	32,0	AC6	50/40	100%	—
1591587	○	150,0	3	10,0	32,0	AC6	125/100	100%	—
1129709	●	150,0	5	10,0	32,0	AC4	80/63	100%	100,0
118017	●	150,0	5	10,0	32,0	AC4	100/80	100%	100,0
118738	●	150,0	5	10,0	32,0	AC4	125/100	100%	100,0
117587	●	150,0	5	10,0	32,0	AC4	160/125	100%	100,0
119146	○	150,0	5	10,0	32,0	AC4	200/160	100%	100,0
1441696	○	150,0	5	12,0	32,0	AC4	125/100	100%	120,0
1425198	○	150,0	5	15,0	32,0	AC6	100/80	100%	150,0
119445	○	150,0	3	20,0	32,0	AC4	80/63	100%	122,0
119444	●	150,0	3	20,0	32,0	AC4	100/80	100%	122,0
119144	●	150,0	3	20,0	32,0	AC4	125/100	100%	122,0

Артикул		D, мм	Толщина алмазного слоя	h, мм	d посадочного отверстия, мм	Марка порошка	Зернистость	Концентрация алмазов	Масса алмазов, караты
118167	●	150,0	3	20,0	32,0	AC4	160/125	100%	122,0
1258386	○	150,0	3	20,0	32,0	AC6	160/125	100%	122,0
1425338	○	150,0	5	20,0	32,0	AC4	63/50	100%	—
1109560	○	150,0	5	20,0	32,0	AC4	80/63	100%	200,0
1107658	●	150,0	5	20,0	32,0	AC4	100/80	100%	200,0
1106394	●	150,0	5	20,0	32,0	AC4	125/100	100%	200,0
119145	●	150,0	5	20,0	32,0	AC4	160/125	100%	200,0
1111197	○	150,0	5	20,0	32,0	AC4	200/160	100%	200,0
1416292	○	150,0	5	20,0	32,0	AC6	50/40	100%	200,0
1108843	○	200,0	3	10,0	76,0	AC4	80/63	100%	82,0
1258288	○	200,0	3	10,0	76,0	AC4	100/80	100%	82,0
1613112	○	200,0	5	10,0	32,0	AC4	100/80	100%	135,0
1583854	○	200,0	5	10,0	76,0	AC4	100/80	100%	135,0
1424940	○	200,0	5	10,0	76,0	AC4	125/100	100%	135,0
1477426	○	200,0	5	15,0	76,0	AC4	125/100	100%	—
1376301	○	200,0	3	20,0	32,0	AC4	100/80	100%	163,0
1111199	○	200,0	3	20,0	32,0	AC4	160/125	100%	163,0
1614310	○	200,0	3	20,0	32,0	ACM	28/20	100%	164,0
1111198	●	200,0	3	20,0	76,0	AC4	100/80	100%	163,0
1356204	○	200,0	5	20,0	16,0	AC4	125/100	100%	270,0
1123830	○	200,0	5	20,0	32,0	AC4	125/100	100%	270,0
1109206	○	200,0	5	20,0	76,0	AC4	80/63	100%	270,0
1107655	●	200,0	5	20,0	76,0	AC4	100/80	100%	270,0
1109207	○	200,0	5	20,0	76,0	AC4	125/100	100%	270,0
1123885	○	200,0	5	20,0	76,0	AC4	160/125	100%	270,0
1441793	○	200,0	5	20,0	76,0	AC4	200/160	100%	270,0
1325970	○	200,0	5	20,0	76,0	AC6	160/125	100%	270,0
1614311	○	200,0	5	20,0	76,0	ACH	60/40	100%	270,0
1326074	○	200,0	5	25,0	32,0	AC4	125/100	100%	337,5
1582277	○	200,0	5	40,0	76,0	AC4	125/100	100%	540,0
1326476	○	250,0	5	8,0	76,0	AC	50/40	100%	—
1326475	○	250,0	5	8,0	76,0	AC	160/125	100%	—
1614312	○	250,0	3	10,0	76,0	AC5C	63/50	100%	102,0
1293035	○	250,0	5	10,0	76,0	AC4	125/100	100%	169,0
1624286	○	250,0	5	10,0	76,0	AC4	200/160	100%	169,0
1614313	○	250,0	5	15,0	76,0	AC4	50/40	100%	254,0
1614314	○	250,0	5	15,0	76,0	AC5C	50/40	100%	254,0
1614315	○	250,0	5	15,0	76,0	ACH	40/28	100%	254,0
1425339	○	250,0	5	20,0	76,0	AC4	160/125	100%	—

Артикул		D, мм	Толщина алмазного слоя	h, мм	d посадочного отверстия, мм	Марка порошка	Зернистость	Концентрация алмазов	Масса алмазов, караты
1256355	○	250,0	5	20,0	76,0	AC	100/80	100%	339,0
1293077	○	250,0	5	20,0	76,0	AC	125/100	100%	339,0
1293078	○	250,0	5	25,0	76,0	AC	125/100	100%	423,8
1276665	○	250,0	5	40,0	76,0	AC	63/50	100%	675,0
1478526	○	300,0	5	15,0	127,0	AC	125/100	100%	306,0
1518054	○	300,0	5	15,0	127,0	AC6	160/125	100%	306,0
1518055	○	300,0	5	15,0	127,0	AC6	200/160	100%	306,0
1260347	○	300,0	5	20,0	76,0	AC4	125/100	100%	408,0
1583512	○	300,0	5	20,0	127,0	AC4	125/100	100%	—
1416800	○	300,0	5	40,0	127,0	AC4	125/100	100%	815,0
1597479	○	350,0	5	20,0	127,0	AC6	100/80	100%	477,0
1378956	○	350,0	5	20,0	127,0	AC6	125/100	100%	477,0
1518056	○	350,0	5	20,0	127,0	AC6	200/160	100%	477,0
1477131	○	350,0	5	25,0	127,0	AC6	80/63	100%	—
1584303	○	350,0	5	40,0	127,0	AC4	125/100	100%	954,0
1343417	○	350,0	5	40,0	127,0	AC6	125/100	100%	954,0
1425340	○	400,0	6	40,0	127,0	AC4	63/50	100%	—
1343418	○	400,0	6	50,0	203,0	AC4	125/100	100%	1635,0

Пасты алмазные полировальные



ГОСТ 25593-83



Артикул		Марка алмазного порошка	Зернистость	Концентрация	Смываемость	Фасовка, г
1335925	○	AC4	80/63	нормальная	органические растворители	50
1262957	○	AC4	100/80	нормальная	органические растворители	50
1262958	○	AC4	125/100	нормальная	органические растворители	50
1269769	○	ACM	1/0	нормальная	органические растворители	50
1326218	○	ACM	2/1	нормальная	органические растворители	50
1583516	○	ACM	2/1	нормальная	органические растворители	100
1262955	○	ACM	3/2	нормальная	органические растворители	50
1613080	○	ACM	5/3	высокая	органические растворители	50
1284276	○	ACM	5/3	нормальная	органические растворители	50
1583517	○	ACM	5/3	нормальная	органические растворители	100
1177516	○	ACM	5/3	повышенная	органические растворители	50
1613081	○	ACM	7/5	высокая	органические растворители	50

Артикул		Марка алмазного порошка	Зернистость	Концентрация	Смываемость	Фасовка, г
1419447	○	АСМ	7/5	нормальная	вода и органические растворители	50
1262947	○	АСМ	7/5	нормальная	органические растворители	50
1729435	○	АСМ	7/5	нормальная	органические растворители	50
1613082	○	АСМ	10/7	высокая	органические растворители	50
1425346	○	АСМ	10/7	нормальная	органические растворители	50
117134	○	АСМ	10/7	повышенная	органические растворители	50
1613083	○	АСМ	14/10	высокая	органические растворители	50
1425347	○	АСМ	14/10	нормальная	органические растворители	50
1740452	○	АСМ	14/10	нормальная	органические растворители	50
117135	○	АСМ	14/10	повышенная	органические растворители	50
1425348	○	АСМ	20/14	нормальная	органические растворители	50
1533167	○	АСМ	20/14	повышенная	органические растворители	100
1614566	○	АСМ	28/20	нормальная	вода	100
1287143	○	АСМ	28/20	нормальная	органические растворители	50
1615235	○	АСМ	28/20	нормальная	органические растворители	50
117137	○	АСМ	28/20	повышенная	органические растворители	50
1262956	○	АСМ	40/28	нормальная	органические растворители	50
1583553	○	АСМ	60/40	высокая	органические растворители	500
1729436	○	АСМ	60/40	высокая	органические растворители	50
1254820	○	АСМ	60/40	нормальная	органические растворители	500
1425349	○	АСМ	60/40	нормальная	органические растворители	50
1615236	○	АСМ	60/40	нормальная	органические растворители	50
1110088	○	АСМ	60/40	повышенная	органические растворители	50

Бруски полировальные



ГОСТ 25594-83

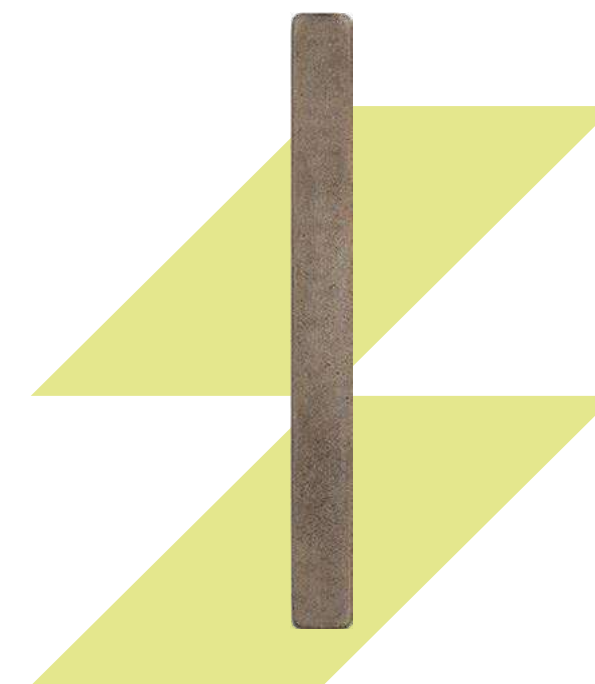

Артикул		L, мм	b, мм	h, мм	R, мм	Марка порошка	Зернистость	Связка	Концентрация алмазов	Масса алмазов в брусках, караты
100022	○	40,0	10,0	3,0	—	АС0	—	—	100%	5,28
1264189	○	40,0	8,0	3,0	—	АС4	160/125	В2-01	100%	4,20
1286926	○	40,0	8,0	3,0	—	АС4	100/80	В2-01	—	4,20
1105074	○	40,0	8,0	3,0	—	АС4	125/100	В2-01	—	4,20
1103101	○	40,0	8,0	3,0	—	АС4	160/125	В2-01	—	4,20
1131135	○	40,0	8,0	3,0	—	АС4	100/80	В2-01	—	4,20
1418446	○	100,0	8,0	4,0	—	АС4	100/80	М2-01	100%	—
1345925	○	100,0	8,0	4,0	—	АС6	100/80	М2-01	100%	7,00
1378268	○	100,0	10,0	4,0	—	АС4	80/63	М2-01	100%	—
1418499	○	100,0	12,0	5,0	—	—	50/40	М2-01	100%	—
100033	○	100,0	4,0	3,0	10,0	АС4	200/160	—	100%	2,60
100034	○	100,0	8,0	4,0	30,0	АС4	200/160	М2-01	100%	7,00
100035	○	100,0	8,0	4,0	40,0	АС4	80/63	М2-01	100%	7,00

Артикул		L, мм	b, мм	h, мм	R, мм	Марка порошка	Зернистость	Связка	Концентрация алмазов	Масса алмазов в брусках, караты
1129638		150,0	16,0	6,0	—	AC4	63/50	M2-01	100%	32,00
1129639		150,0	16,0	6,0	—	AC4	80/63	M2-01	100%	32,00
100039		100,0	8,0	4,0	30,0	AC5C	200/160	M2-01	100%	7,00
100041		75,0	6,0	4,0	30,0	AC6	200/160	M2-01	100%	4,00
100038		100,0	4,0	3,0	10,0	AC4	200/160	—	100%	2,60
100042		75,0	6,0	4,0	30,0	AC6	63/50	M2-01	100%	7,00
100040		40,0	2,0	2,0	5,0	AC6	200/160	—	100%	0,53
100043		100,0	10,0	4,0	40,0	AC6	125/100	M2-01	100%	8,80
100044		100,0	10,0	4,0	40,0	AC6	200/160	M2-01	100%	8,80
1107413		100,0	8,0	4,0	30,0	AC6	125/100	M2-01	100%	7,00
100045		100,0	8,0	4,0	30,0	AC6	200/160	M2-01	100%	7,00
100046		100,0	8,0	4,0	30,0	AC6	63/50	M2-01	100%	8,80
100047		100,0	8,0	4,0	40,0	AC6	125/100	M2-01	100%	8,80
100048		100,0	8,0	4,0	40,0	AC6	200/160	M2-01	100%	7,00
100049		100,0	8,0	4,0	40,0	AC6	80/63	M2-01	100%	8,80
100055		50,0	3,0	3,0	5,0	ACM	60/40	M2-01	100%	0,99
100057		100,0	8,0	4,0	16,0	ACM	60/40	M2-01	100%	7,00
100058		100,0	8,0	4,0	30,0	ACM	200/160	M2-01	100%	7,00
100059		100,0	8,0	4,0	30,0	ACM	40/28	M2-01	100%	7,00
100060		100,0	8,0	4,0	30,0	ACM	60/40	M2-01	100%	7,00
100065		75,0	6,0	4,0	30,0	ACM6	40/28	M2-01	100%	4,00
100067		100,0	8,0	4,0	30,0	ACM6	40/28	M2-01	100%	7,00
100068		100,0	8,0	4,0	30,0	ACMC	60/40	M2-01	100%	7,00
100069		100,0	8,0	4,0	16,0	ACH	50/40	M2-01	100%	7,00
100026		50,0	4,0	4,0	10,0	—	200/160	M5-01	100%	1,76
100027		100,0	8,0	4,0	30,0	—	160/125	M5-01	100%	7,00
100028		100,0	8,0	4,0	30,0	—	200/160	M5-01	100%	7,00
100029		100,0	8,0	4,0	40,0	—	200/160	M5-01	100%	7,00
100050		75,0	6,0	4,0	20,0	AC6	80/63	M5-01	100%	4,00
100051		75,0	6,0	4,0	30,0	AC6	200/160	M5-01	100%	4,00
100036		100,0	8,0	4,0	30,0	AC4	80/63	M5-03	100%	7,00
100061		50,0	4,0	3,0	6,0	ACM	28/20	M5-04	100%	1,76
100062		50,0	4,0	4,0	6,0	ACM	40/28	M5-04	100%	1,76
100063		50,0	4,0	4,0	10,0	ACM	40/28	M5-04	100%	1,76
100064		100,0	8,0	4,0	16,0	ACM	60/40	M5-04	100%	7,00
100037		100,0	8,0	4,0	30,0	AC4	200/160	M5-05	100%	7,00
100052		100,0	8,0	4,0	16,0	AC6	200/160	M5-05	100%	7,00
100054		75,0	6,0	5,0	50,0	AC6	160/125	M5-06	100%	5,90
100070		100,0	8,0	4,0	40,0	ACH	80/63	MC-01	100%	7,00

Надфили алмазные

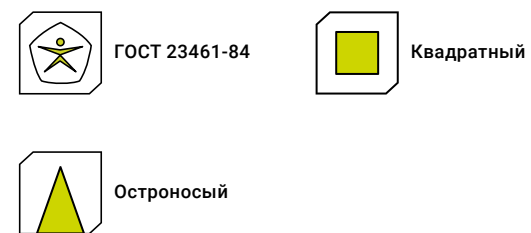

Артикул		L, мм	Марка порошка	Зернистость
103733		120,0	—	—
1242922		140,0	—	—
1108572		160,0	—	—
1337400		160,0	AC6	100/80
1478421		160,0	AC6	80/63
1102289		180,0	—	—

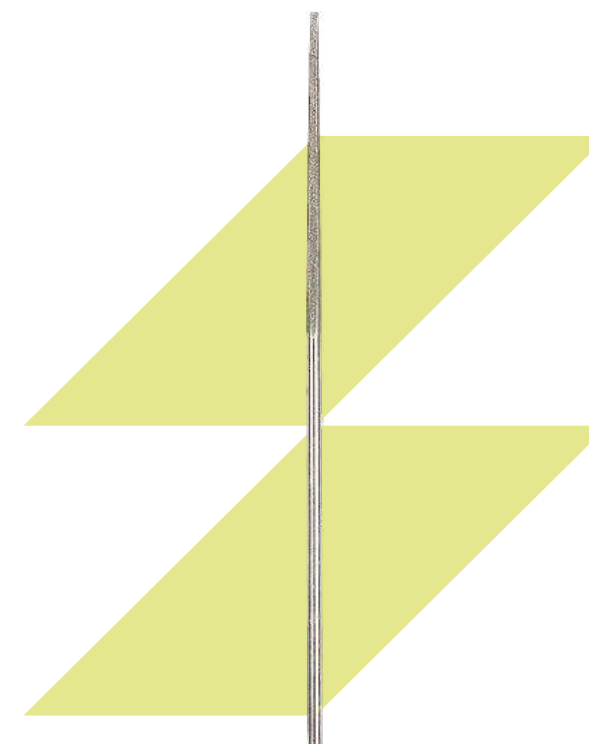

Надфили алмазные

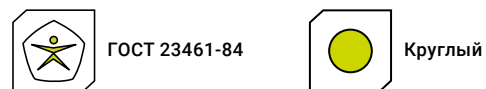

Артикул		L, мм	Марка порошка	Зернистость
1331103		120,0	—	—
1591787		120,0	AC6	160/125
1111072		140,0	—	—
1102527		160,0	—	—
1425311		160,0	AC4	100/80
103734		160,0	AC4	125/100
1425312		160,0	AC6	80/63
1337399		160,0	AC6	100/80
118845		180,0	—	—

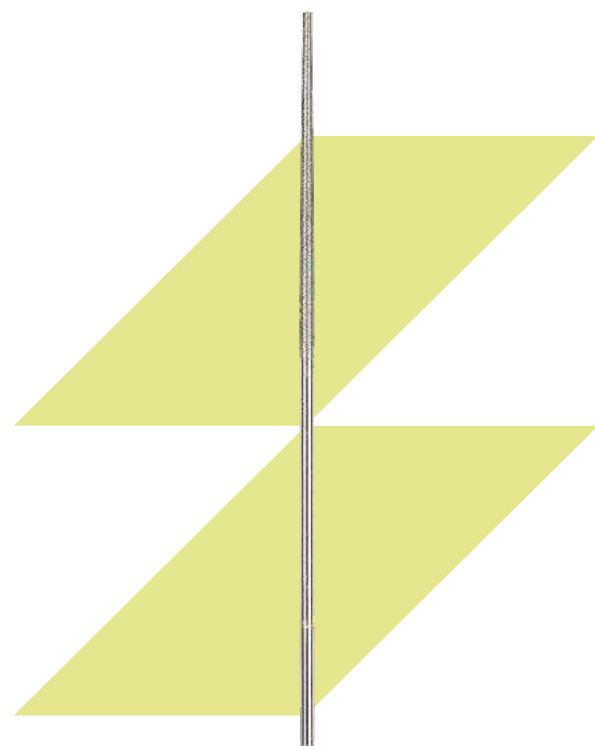

Надфили алмазные



Артикул		L, мм	Марка порошка	Зернистость
1331104		120,0	—	—
1424985		120,0	AC4	100/80
1111073		140,0	—	—
1102526		160,0	—	—

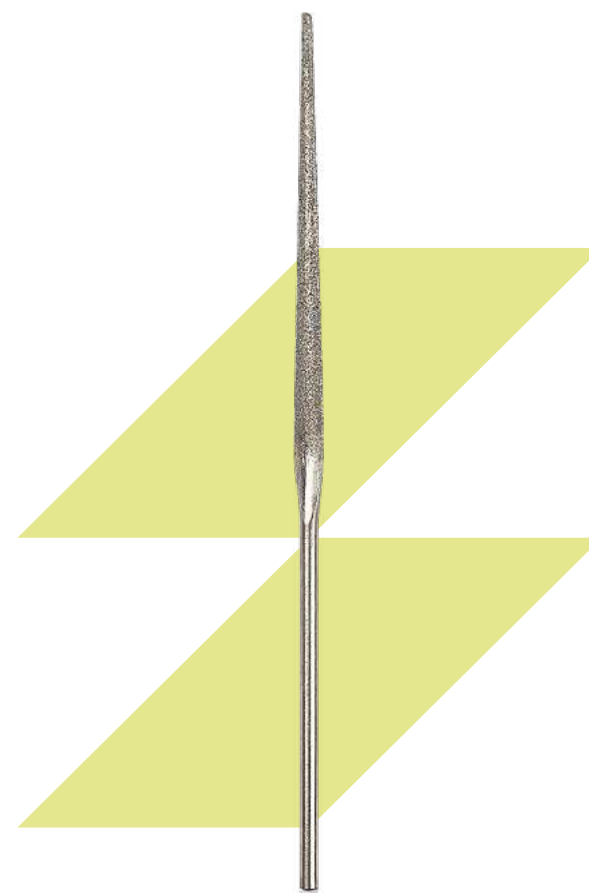

Надфили алмазные

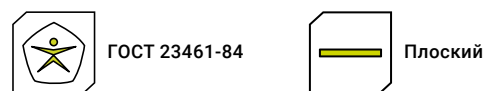

Артикул		L, мм	Марка порошка	Зернистость
1424999		120,0	АС4	100/80
1343189		120,0	АС6	100/80
1343190		120,0	АС6	50/40
1425313		160,0	АС4	100/80
1425314		160,0	АС6	80/63
1591788		160,0	АС6	160/125

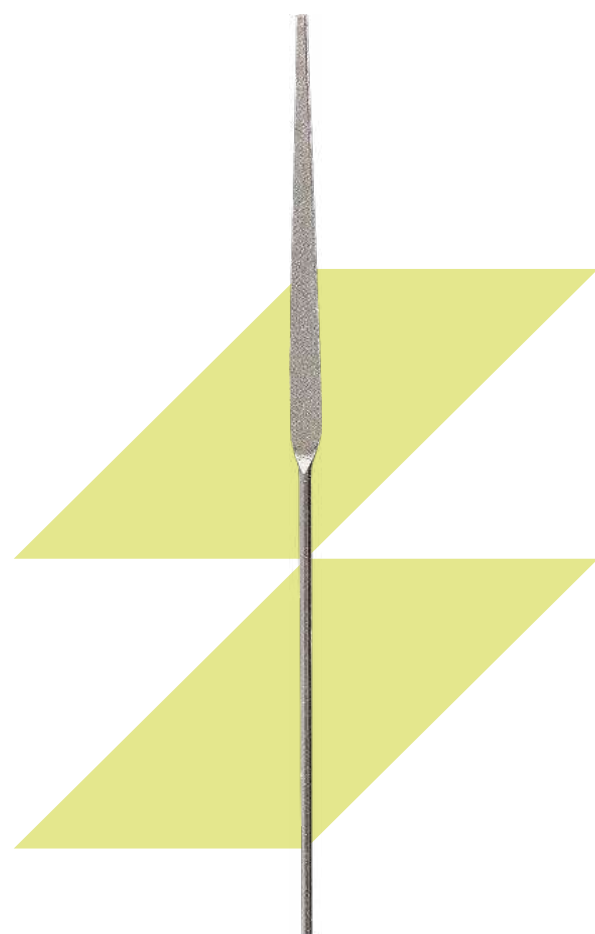

Надфили алмазные

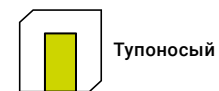

Артикул		L, мм	Марка порошка	Зернистость
1343188		100,0	АС6	50/40
1424988		120,0	АС4	100/80
1418034		120,0	АС6	100/80
1477546		120,0	АС6	125/100
1343191		120,0	АС6	50/40
103735		120,0	АС15	80/63
1424989		160,0	АС4	100/80
1477479		160,0	АС4	50/40
1425315		160,0	АС6	100/80
1584098		160,0	АС6	160/125
1591789		160,0	АС6	50/40
1478422		160,0	АС6	80/63
1533042		160,0	АС15	100/80
1418872		160,0	АС15	125/100
1418873		160,0	АС15	160/125
1418871		160,0	АС15	50/40
1533041		160,0	АС15	80/63

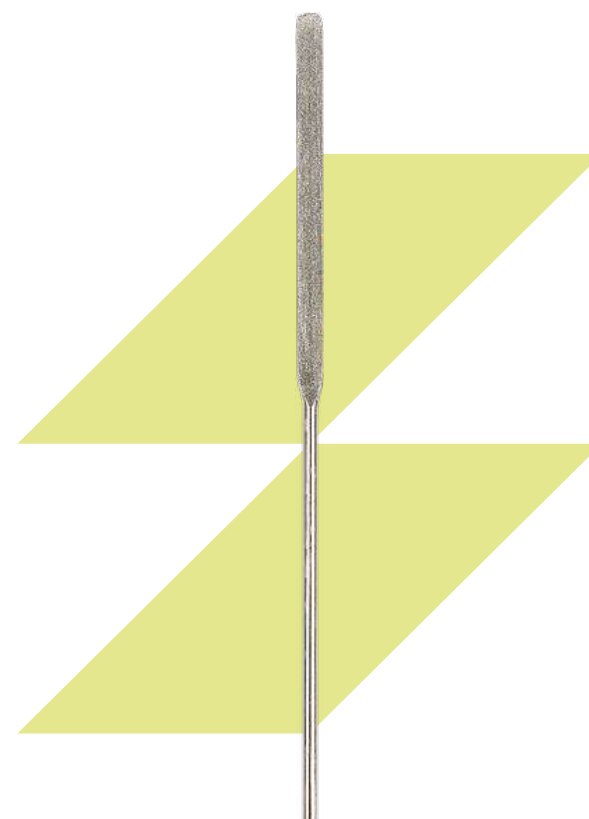

Надфили алмазные



ГОСТ 23461-84



Полукруглый



Остроносый

Артикул		L, мм	Марка порошка	Зернистость
1418387		120,0	—	—
1111070		140,0	—	—
1102525		160,0	—	—
1425316		160,0	AC4	80/63
1425317		160,0	AC6	100/80
1591790		160,0	AC6	50/40
1477802		160,0	AC6	80/63
1104624		180,0	—	—

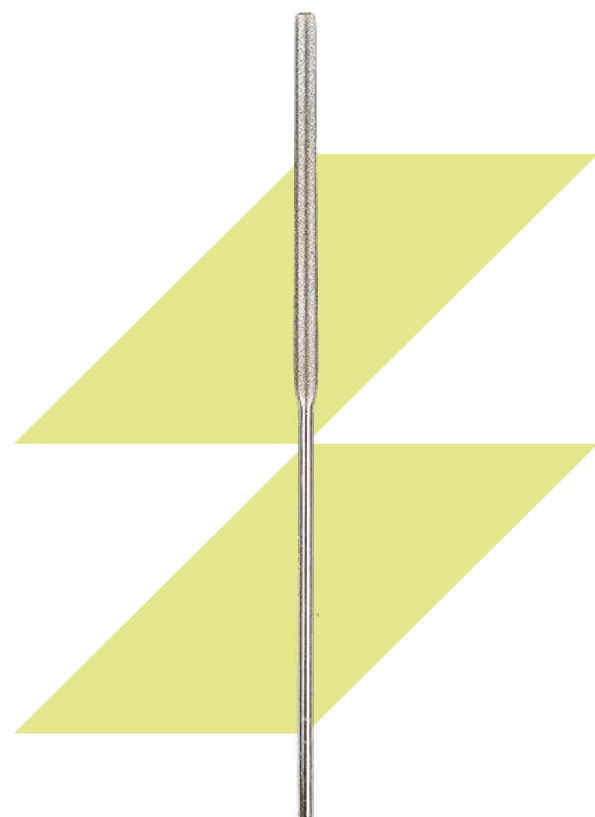

Надфили алмазные



ГОСТ 23461-84



Ромбический



Тупоносый

Артикул		L, мм	Марка порошка	Зернистость
1417830		120,0	—	—
1242050		160,0	—	—
103737		180,0	—	—

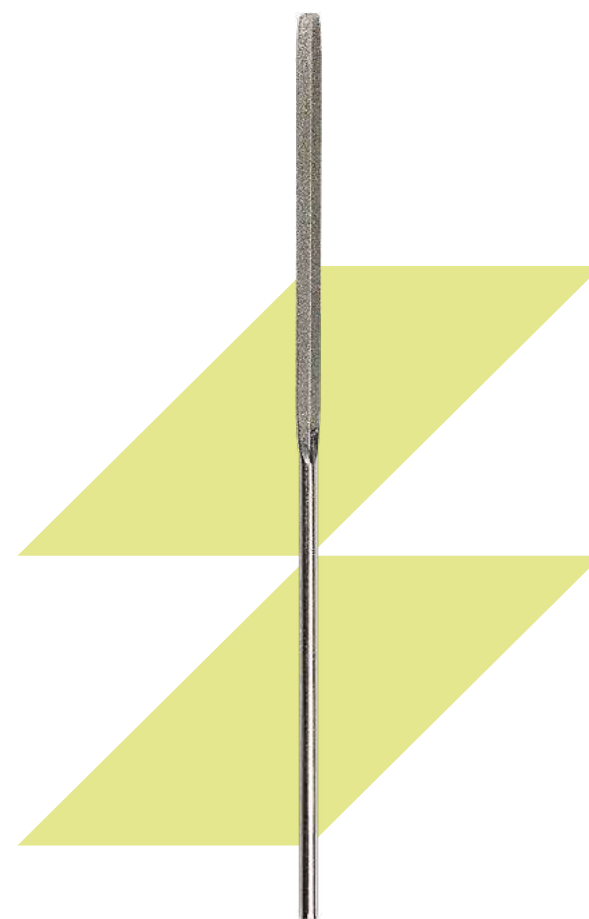

Надфили алмазные равнобедренные



ГОСТ 23461-84



Трехгранный

Артикул		L, мм	Марка порошка	Зернистость
1424990	●	120,0	AC4	100/80
1343192	○	120,0	AC6	100/80
1418035	○	120,0	AC6	125/100
1343193	○	120,0	AC6	50/40
1425318	●	160,0	AC4	80/63
1337398	●	160,0	AC4	100/80

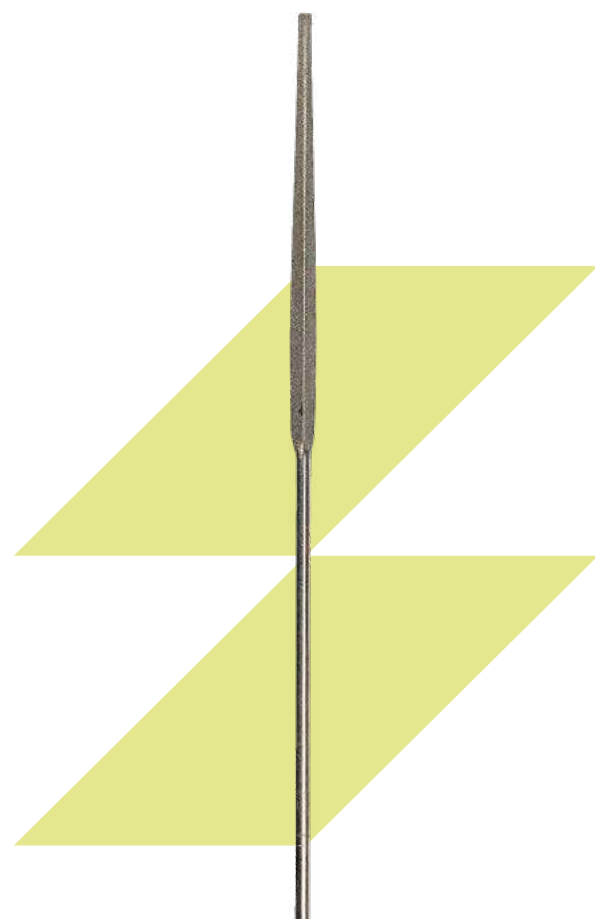

Круги алмазные отрезные



ГОСТ 32833-2014



Металлическая



1A1R



Металлическая



Артикул		D, мм	Ширина алмазного слоя	Толщина алмазного слоя	Связка	d посадочного отверстия, мм	Марка порошка	Зернистость
1418789	○	50,0	2,5	0,15	M2-02	12,0	AC32	80/63
1418790	○	50,0	5,0	0,15	M2-02	12,0	AC15	80/63
1418791	○	50,0	2,5	0,20	M2-02	12,0	AC15	80/63
1418792	○	50,0	2,5	0,20	M2-02	12,0	AC32	63/50
1418793	○	50,0	2,5	0,20	M2-02	12,0	AC80	63/50
1418794	○	50,0	5,0	0,50	M2-02	12,0	AC15	100/80
1418795	○	90,0	5,0	0,45	M2-02	20,0	AC80	150/125
1418796	○	100,0	5,0	0,45	M2-02	20,0	AC15	160/125
1418797	○	100,0	5,0	0,45	M2-02	20,0	AC50	100/80
1269439	○	100,0	5,0	0,80	M2-02	32,0	AC15	100/80
1614299	○	150,0	5,0	0,45	M2-02	32,0	AC32	80/63
1518235	○	150,0	5,0	0,80	M2-02	32,0	AC4	100/80

Артикул		D, мм	Ширина алмазного слоя	Толщина алмазного слоя	Связка	d посадочного отверстия, мм	Марка порошка	Зернистость
1614300	○	150,0	5,0	0,80	M2-02	32,0	AC32	80/63
1518236	○	150,0	5,0	1,00	M2-02	32,0	AC4	100/80
1583522	○	150,0	5,0	1,00	M2-02	32,0	AC6	100/80
1478445	○	150,0	5,0	1,00	M2-02	32,0	AC20	125/100
1614301	○	150,0	5,0	1,00	M2-02	32,0	AC32	80/63
1478447	○	150,0	5,0	1,20	M2-02	32,0	AC20	125/100
1583523	○	150,0	5,0	1,50	M2-02	32,0	AC6	100/80
1478446	○	150,0	5,0	1,50	M2-02	32,0	AC20	125/100
1583524	○	150,0	5,0	2,00	M2-02	32,0	AC6	100/80
1583525	○	150,0	5,0	2,50	M2-02	32,0	AC15	100/80
1614302	○	175,0	5,0	0,60	M2-02	32,0	AC32	80/63
1614303	○	175,0	5,0	0,80	M2-02	32,0	AC32	80/63
1614304	○	175,0	5,0	1,00	M2-02	32,0	AC32	80/63
1614316	○	200,0	5,0	0,80	M2-02	32,0	AC15	63/50
1614317	○	200,0	5,0	1,00	M2-02	32,0	AC15	63/50
1614318	○	200,0	5,0	1,00	M2-02	32,0	AC15	125/100
1614319	○	200,0	5,0	1,20	M2-02	32,0	AC15	63/50
1614320	○	200,0	5,0	1,50	M2-02	32,0	AC15	63/50
1614321	○	200,0	5,0	1,50	M2-02	32,0	AC15	200/160
1614322	○	200,0	5,0	2,00	M2-02	32,0	AC15	63/50
1614323	○	200,0	5,0	2,20	M2-02	32,0	AC15	63/50
1614324	○	200,0	5,0	2,50	M2-02	32,0	AC15	63/50
1729175	○	75,0	5,0	0,25	M2-01	12,0	AC20	80/63
1235215	○	100,0	5,0	0,80	M2-01	20,0	AC32	160/125
1260357	○	100,0	5,0	1,00	M2-01	32,0	AC20	125/100
1518177	○	125,0	5,0	0,45	M2-01	32,0	AC32	100/80
1425341	○	125,0	5,0	0,60	M2-01	32,0	AC6	125/100
1269441	○	125,0	5,0	1,00	M2-01	32,0	AC15	100/80
1418821	○	150,0	5,0	1,00	M2-01	32,0	AC6	80/63
1729284	○	150,0	5,0	1,00	M2-01	32,0	AC20	125/100
1585367	○	150,0	5,0	1,20	M2-01	32,0	AC20	160/125
1425342	○	150,0	5,0	1,50	M2-01	32,0	AC20	125/100
1425342	○	150,0	5,0	1,50	M2-01	32,0	AC20	125/100
1591637	○	150,0	5,0	1,50	M2-01	32,0	AC20	160/125
1518178	○	150,0	5,0	1,50	M2-01	32,0	AC32	160/125
1269440	○	150,0	5,0	2,00	M2-01	32,0	AC15	125/100
1585368	○	150,0	5,0	2,00	M2-01	32,0	AC15	200/160
1591638	○	150,0	5,0	2,00	M2-01	32,0	AC20	200/160
1335621	○	175,0	5,0	1,00	M2-01	32,0	AC20	100/80

Артикул		D, мм	Ширина алмазного слоя	Толщина алмазного слоя	Связка	d посадочного отверстия, мм	Марка порошка	Зернистость
1323762	○	180,0	5,0	1,20	M2-01	32,0	AC50	250/200
1740500	○	200,0	5,0	1,00	M2-01	32,0	AC6	80/63
1425343	○	200,0	5,0	1,20	M2-01	32,0	AC15	160/125
1326215	○	200,0	5,0	1,20	M2-01	32,0	AC32	250/200
1326216	○	200,0	5,0	1,50	M2-01	32,0	AC32	250/200
1326217	○	200,0	5,0	2,00	M2-01	32,0	AC6	125/100
1177671	○	250,0	5,0	2,00	M2-01	32,0	AC15	200/160
1425344	○	350,0	5,0	2,20	M2-01	32,0	AC6	125/100

Алмазы в оправе



ГОСТ 22908-78



Артикул		Хвостовик	Тип	D, мм	Диаметр хвостовика, мм	L, мм	Масса, караты	Угол державки α, градусы
1597334		цилиндрический	1	10,0	10,0	50,0	0,61–0,85	120
1585518		цилиндрический	1	12,0	12,0	50,0	0,21–0,30	90
1612533		цилиндрический	2	12,0	8,0	32,0	0,11–0,20	120
1643123		конический (B12)	3	12,2	—	32,0	0,86–1,10	120

Артикул		Хвостовик	Тип	D, мм	Диаметр хвостовика, мм	L, мм	Масса, караты	Угол державки α, градусы
1135422		цилиндрический	1	6,0	6,0	50,0	0,06–0,10	90
1269663		цилиндрический	1	6,0	6,0	50,0	0,11–0,20	120
1236280		цилиндрический	1	6,0	6,0	50,0	0,11–0,14	90
1284860		цилиндрический	1	6,0	6,0	50,0	0,11–0,20	90
1134865		цилиндрический	1	6,0	6,0	50,0	0,16–0,20	90
1343115		цилиндрический	1	6,0	6,0	50,0	0,16–0,20	90
1262891		цилиндрический	1	6,0	6,0	50,0	0,11–0,20	120
1585517		цилиндрический	1	8,0	8,0	25,0	0,11–0,20	90
1284861		цилиндрический	1	8,0	8,0	25,0	0,21–0,30	90
1140362		цилиндрический	1	8,0	8,0	50,0	0,21–0,30	120
1262892		цилиндрический	1	10,0	10,0	50,0	0,41–0,60	120
1740098		цилиндрический	1	10,0	10,0	50,0	0,61–0,85	90

Иглы алмазные



ГОСТ 17564-85

Артикул		D, мм	L, мм	Масса, караты	Обозначение по ГОСТ
1109345	○	6,0	35,0	0,10–0,20	3908-0031
1111022	○	6,0	35,0	0,32	3908-0032
1130002	○	6,0	35,0	0,21–0,30	3908-0033
1227129	○	6,0	35,0	0,21–0,30	3908-0034
1418442	○	8,0	35,0	0,21–0,30	3908-0035
1140369	○	8,0	35,0	0,11–0,20	3908-0036
1109346	○	8,0	35,0	0,21–0,30	3908-0037
1336040	○	8,0	35,0	0,21–0,30	3908-0037
1111023	○	8,0	35,0	0,32	3908-0038
1582354	○	10,0	50,0	0,20–0,30	3908-0044
1418558	○	10,0	50,0	0,20–0,30	3908-0045
1130004	○	10,0	50,0	0,21–0,30	3908-0048

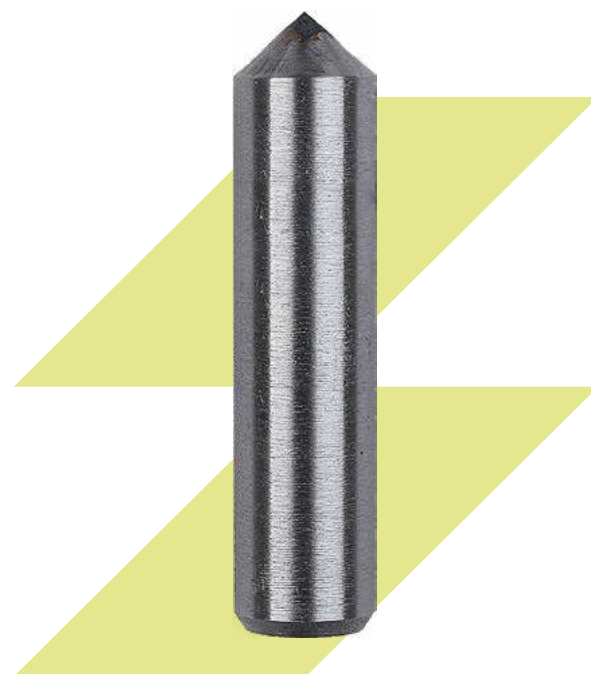

Карандаши алмазные



ГОСТ 607-80

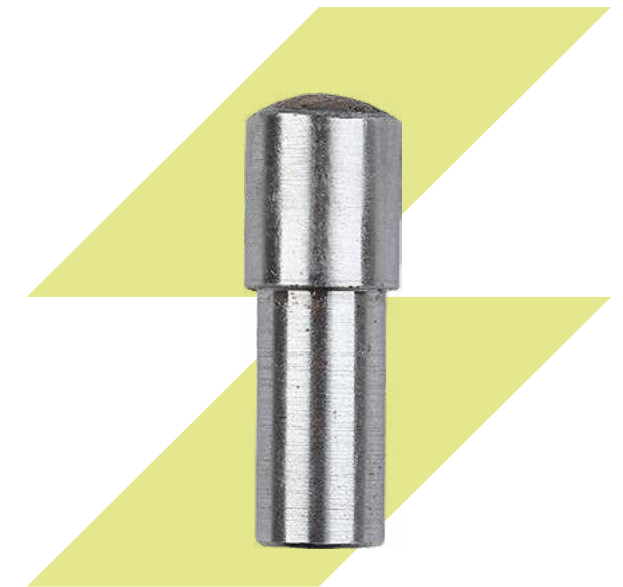

Артикул		Тип	Исполнение	Масса, караты	D, мм	L, мм	Обозначение по ГОСТ
1240018	●	01	A	0,5	10,0	55,0	3908-0051
102021	○	01	A	0,5	10,0	45,0	3908-0052
102022	○	01	A	0,5	10,0	45,0	3908-0052
102023	●	01	A	0,5	10,0	45,0	3908-0053
102025	○	01	A	1,0	10,0	45,0	3908-0054
102029	○	01	A	1,0	10,0	45,0	3908-0054
1104986	○	01	A	0,31–0,5	10,0	45,0	3908-0055
102030	○	01	A	0,31–0,5	10,0	45,0	3908-0055
102031	○	04	A	0,5	6,0	45,0	3908-0056
102032	○	04	A	0,5	6,0	45,0	3908-0057
102033	○	04	A	0,5	6,0	45,0	3908-0058
1240470	●	04	A	1,0	8,0	45,0	3908-0059

Артикул		Тип	Исполнение	Масса, караты	D, мм	L, мм	Обозначение по ГОСТ
102034	○	04	A	1,0	8,0	45,0	3908-0060
102035	●	04	A	1,0	8,0	45,0	3908-0061
1102811	●	04	A	1,0	8,0	45,0	3908-0062
1240019	●	04	A	1,0	8,0	45,0	3908-0063
102036	●	04	A	1,0	8,0	45,0	3908-0064
102037	○	04	A	1,0	10,0	45,0	3908-0065
102038	●	04	A	1,0	10,0	45,0	3908-0066
102039	●	04	A	1,0	10,0	45,0	3908-0067
1105627	○	04	A	1,0	10,0	45,0	3908-0068
1614293	○	04	A	2,0	10,0	45,0	3908-0069
1582528	○	01	B	0,5	10,0	70,0	3908-0070
1265224	○	02	B	1,0	10,0	60,0	3908-0074
1265225	○	02	B	1,0	10,0	60,0	3908-0075
1269712	○	02	B	1,0	12,0	60,0	3908-0076
1614294	○	02	B	1,0	12,0	60,0	3908-0077
1240471	●	02	C	1,0	14,0	45,0	3908-0081
102041	●	02	C	1,0	14,0	45,0	3908-0082
102042	○	02	C	1,0	14,0	45,0	3908-0082
102043	●	02	C	1,0	14,0	45,0	3908-0083
1261411	○	02	C	1,0	14,0	45,0	3908-0083
102047	●	02	C	2,0	14,0	45,0	3908-0084
102050	○	02	C	2,0	14,0	45,0	3908-0084
1425323	○	02	C	1,0	14,0	45,0	3908-0085
1417609	●	02	C	1,0	14,0	45,0	3908-0086
102051	●	02	C	1,0	14,0	45,0	3908-0087
102052	●	02	C	1,0	14,0	45,0	3908-0088
118336	●	04	C	2,0	14,0	45,0	3908-0091
1105358	●	04	C	2,5	14,0	45,0	3908-0092
1110090	●	04	C	2,0	14,0	45,0	3908-0093

Для заметок

Blank lined area for notes.



Пневмоинструмент

Пнемогайковерты	974
Пневмовинтоверты	975
Пневмомолотки рубильные	976
Пневмопистолеты продувочные	977
Пневмосверлилки	978
Пневмошлифмашины	980

Пневмогайковерты

Пневмогайковерты применяются для закручивания и демонтажа гаек и болтов. Работают за счет сжатого воздуха, что исключает возможность возгорания. Реверс помогает вывинтить застрявшую оснастку без дополнительных приспособлений, а степень затяжки болтов контролируется регулятором. Корпус инструмента отличается повышенной прочностью и устойчивостью к механическим повреждениям. Прорезиненная рукоятка обеспечивает надежный хват.



Пневмовинтоверты

Пневмовинтоверты применяются для закручивания и демонтажа крепежа. Принцип работы на сжатом воздухе гарантирует низкую пожаро- и взрывоопасность рабочего процесса. Модель отличается внушительным рабочим ресурсом и возможностью длительной работы без остановки. Малый вес инструмента снижает энергоемкость рабочего процесса. Пневмовинтоверты оснащены удобным переключателем режима реверса. Удобная форма рукоятки обеспечивает надежный хват.



Пневмомолотки рубильные

Пневматические рубильные молотки используются при отбойных и зачистных работах для демонтажа твердых материалов. Работа на сжатом воздухе обеспечивает инструмент внушительным рабочим ресурсом. Металлическая конструкция устойчива к механическим повреждениям. Края рукоятки тщательно сглажены, что обеспечивает комфортный хват, а пружина на хвостовике гасит вибрацию при работе.



Пневмопистолеты продувочные

Продувочные пневматические пистолеты используются для очистки поверхностей от пыли и загрязнений. Жесткий ударопрочный корпус обеспечивает продолжительный срок службы. Удлиненное сопло позволяет работать даже в труднодоступных местах. Пистолеты оснащены специальной петлей для удобного хранения.



Пневмосверлилки

Пневмодрели применяются для сверления отверстий в дереве, металле и пластике, а также завинчивания и отвинчивания винтов и шурупов с резьбой. Принцип работы на сжатом воздухе обеспечивает устойчивость к перегрузкам и перегреву. Имеют легкий вес и малые размеры для удобства работы.



Пневмошлифмашины

Пневмошлифмашины используются для шлифования тонких сварных швов, обработки контуров, полировки поверхностей. Позволяют быстро снимать материал, исключая появление царапин и обеспечивая равномерность обработки. Легкий и прочный корпус из композитных материалов устойчив к механическим повреждениям. Регулируемая частота вращения позволяет подбирать оптимальный режим работы. Сниженный уровень вибрации делает рабочий процесс более комфортным.



Условные обозначения

Наличие инструмента

- На складе в Нижнем Новгороде
- Под заказ

Пневмогайковерты



Артикул	Размер патрона	Расход воздуха, л/мин.	Давление, атм	Крутящий момент, Нм	Частота вращения шпинделя, об/мин.	Вес, кг
1729450	1/2	226	6,3	340	7000	2

Пневмовинтоверты AIW1366



Артикул	Размер патрона	Расход воздуха, л/мин.	Давление, атм	Крутящий момент, Нм	Частота вращения шпинделя, об/мин.	Вес, кг
1729449	1/2	150	6,3	660	8500	2,65

Пневмомолотки



Артикул		Сила удара, Дж	Частота ударов, уд/мин.	Расход воздуха, л/мин.	Давление, атм	Вес, кг
1729451	●	14	2100	1300	6,3	5,9

Пневмопистолеты продувочные



Артикул		Расход воздуха, л/мин.	Давление, атм
1729452	●	200	6
1729453	●	400	10

Пневмосверлилки без реверса



Артикул	Наименование	Размер патрона, мм	Макс. диаметр сверления (металл), мм	Расход воздуха, л/мин.	Давление, атм	Частота вращения шпинделя, об/мин.	Вес, кг
1729454	СМ21-6-12000	6	6	800	6,3	12000	1,00
1729455	СМ21-10-270	10	10	800	6,3	300	1,35
1729456	СМ21-10-2300	10	10	800	6,3	2300	1,20

Пневмосверлилки без реверса

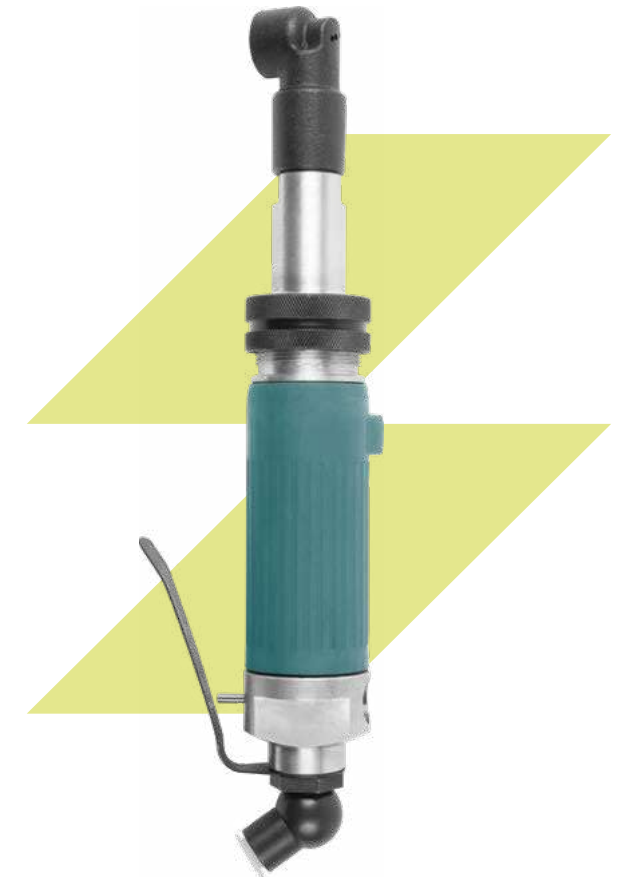

Артикул	Наименование	Макс. диаметр сверления (металл), мм	Расход воздуха, л/мин.	Размер патрона, мм	Давление, атм	Частота вращения шпинделя, об/мин.	Вес, кг
1772449	УСМ12-6-3000	6	800	6	6,3	12000	1

Пневмошлифмашины прямые S60A



Артикул	Диаметр круга, мм	Толщина круга, мм	Посадочный диаметр круга, мм	Расход воздуха, л/мин.	Давление, атм	Частота вращения, об/мин.	Вес, кг
1729457	63	20	20	870	6,3	13000	2

Пневмошлифмашины прямые ПМЗ-31-250



Артикул	Диаметр цанги, мм	Расход воздуха, л/мин.	Давление, атм	Частота вращения шпинделя, об/мин.	Вес, кг
1729458	8	900	6,3	15000	1,5

Пневмошлифмашины прямые ИП-2014Б



Для заметок

Area for notes with horizontal dashed lines.

Артикул	Диаметр круга, мм	Толщина круга, мм	Посадочный диаметр круга, мм	Расход воздуха, л/мин.	Давление, атм	Частота вращения, шпинделя, об/мин.	Вес, кг
1729459	150	25	32	1500	5	5100	4,2