

Fine boring systems

User-friendly interface

Feinbohrsysteme

Benutzerfreundliche Schnittstelle

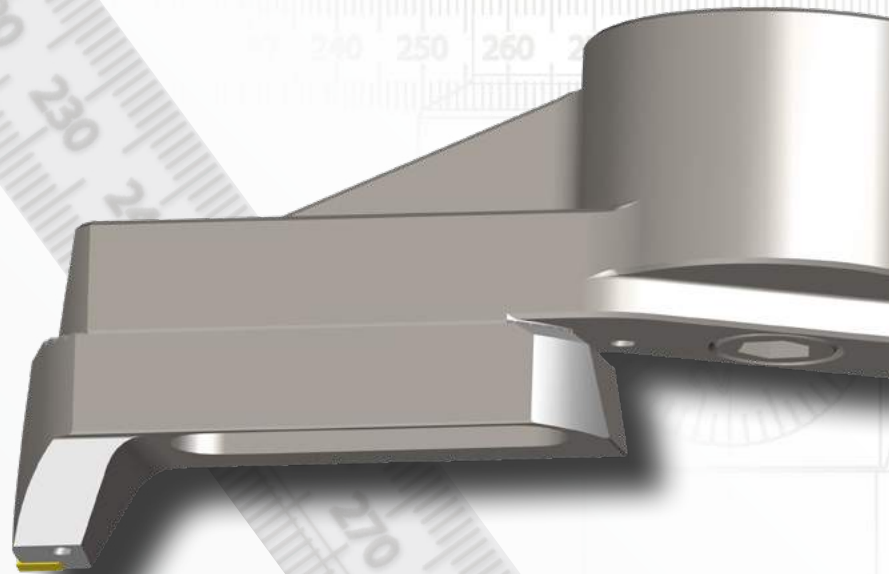

ZCC Cutting Tools Europe GmbH

your Partner | your Value

HERZLICH WILLKOMMEN BEI ZCC CUTTING TOOLS EUROPE

ZCC-CT, einer der weltweit führenden Hartmetall-Werkzeughersteller, begrüßt Sie recht herzlich. Mit unserer umfangreichen Produktpalette an Hochleistungs-Zerspanungswerkzeugen und entsprechenden Serviceleistungen möchten wir gerne bei Ihnen die Bearbeitungssicherheit und die Wirtschaftlichkeit erhöhen.

Wir freuen uns auf eine gute Zusammenarbeit.

Ihr Team von ZCC Cutting Tools Europe steht Ihnen als Partner zur Seite!

WELCOME TO ZCC CUTTING TOOLS EUROPE

ZCC-CT, one of the world's leading carbide tooling manufacturers, welcomes you to its products. We are able to offer you a wide product range of high performance cutting tools at economic prices and a good supply service to support the production and productivity at your manufacturing facilities.

We are looking forward to working with you and developing good cooperation together. Our team at ZCC Cutting Tools Europe is ready to support you in all of your requirements.



Member of Minmetals Group



HAUPTSITZ IN EUROPA/ EUROPEAN HEADQUARTER :

ZCC Cutting Tools Europe GmbH, Wanheimer Str. 57, 40472 Düsseldorf, Germany

Tel.: +49 (0) 211/989240-0, Fax: +49 (0) 211/ 989240-111

E-Mail: info@zccct-europe.com, www.zccct-europe.com, www.zccct.com



Fine boring bridge tools Ø85.5-650.1 Feinbohrbrückenwerkzeuge Ø85.5-650.1

90504.206



- Diameter setting with minimal reversal backlash
- 0.01mm diametrical adjustment
- With inner coolant supply

- Durchmessereinstellung mit geringstem Umkehrspiel
- Zustellgenauigkeit von 0.01mm im Durchmesser
- Mit Innenkühlung

Part number Bestell-Nr./	Ø D/ System	Ø A min.	Ø A max.	L	Fine bore adapter/ Feinbohraufsatz
90504.206.320.000	78 / D32	85.5	140.1	98	90504.207.000.006 (CC..0602..)
90504.206.321.000	78 / D32	139.5	220.1	98	90504.207.001.006 (CC..0602..)
90504.206.322.000	78 / D32	219.5	310.1	98	90504.207.001.006 (CC..0602..)
90504.206.400.000	88 / D40	309.5	395.1	108	90504.207.001.006 (CC..0602..)
90504.206.401.000	88 / D40	394.5	480.1	108	90504.207.001.006 (CC..0602..)
90504.206.600.000	128 / D60	479.5	565.1	118	90504.207.001.006 (CC..0602..)
90504.206.601.000	128 / D60	564.5	650.1	118	90504.207.001.006 (CC..0602..)

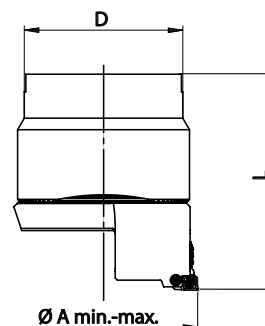

- clamp tool in a shell mill holder.
- **insert holder included**

- Werkzeug in einer Fräsdorn- oder Messerkopfaufnahme spannen.
- **inklusive Wendepaltenhalter**

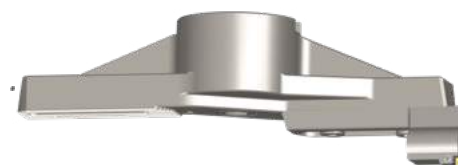

Twin cutter bridge tools Ø85.5-650.1 Zweischneiderbrückenwerkzeuge Ø85.5-650.1

90504.208

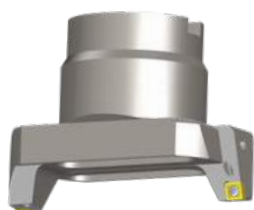

- with inner coolant supply

- mit Innenkühlung

Part number Bestell-Nr./	Ø D/ System	Ø A min.	Ø A max.	L	Wendepaltenhalter / Insert holder
90504.208.320.000	78 / D32	85.5	140.1	98	90504.209.000.012 (CC..1204..)
90504.208.321.000	78 / D32	139.5	220.1	98	90504.209.001.012 (CC..1204..)
90504.208.322.000	78 / D32	219.5	310.1	98	90504.209.001.012 (CC..1204..)
90504.208.400.000	88 / D40	309.5	395.1	108	90504.209.001.012 (CC..1204..)
90504.208.401.000	88 / D40	394.5	480.1	108	90504.209.001.012 (CC..1204..)
90504.208.600.000	128 / D60	479.5	565.1	118	90504.209.001.012 (CC..1204..)
90504.208.601.000	128 / D60	564.5	650.1	118	90504.209.001.012 (CC..1204..)

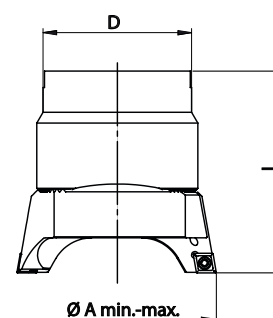

- clamp tool in a shell mill holder.
- **insert holder included**

- Werkzeug in einer Fräsdorn- oder Messerkopfaufnahme spannen.
- **inklusive Wendepaltenhalter**

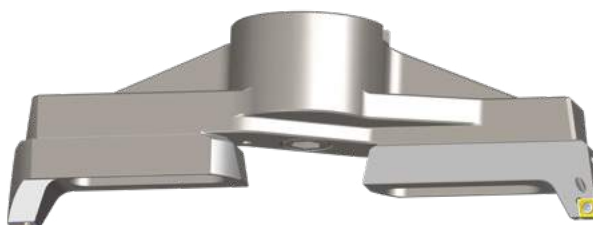

Twin cutter boring heads
Zweischneiderköpfe

90504.141



Part number/ Bestell-Nr.	Ø D/ System	Ø A min.	Ø A max.	L	Insert holder w/ Wendeplattenhalter
90504.141.320.000	32 / ER25	39.5	51.1	65	90504.162.320.009 (CC..09T3..) 90504.166.320.009 (CC..09T3..) 90504.167.320.009 (CC..09T3..) 90504.182.320.009 (CC..09T3..)
90504.141.420.000	42 / ER32	49.5	67.1	75	90504.162.420.009 (CC..09T3..) 90504.166.420.009 (CC..09T3..) 90504.167.420.009 (CC..09T3..) 90504.182.420.009 (CC..09T3..)
90504.141.550.000	55 / ER40	65.5	87.1	85	90504.162.550.112 (CC..1204..) 90504.166.520.112 (CC..1204..) 90504.167.550.112 (CC..1204..) 90504.182.550.112 (CC..1204..)

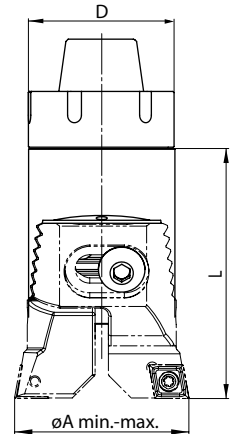

- Clamp tool in a collet chuck.
- **Insert holder included**
- Werkzeug in einem Spannzangenfutter spannen.
- **Inklusive Wendeplattenhalter**

Twin cutter boring heads
Zweischneiderköpfe

90504.142



Part number/ Bestell-Nr.	Ø D/ System	Ø A min.	Ø A max.	L	Insert holder / Wendeplattenhalter
90504.142.200.000	20	23.5	31.1	150	90504.162.200.006 (CC..0602..) 90504.166.200.006 (CC..0602..) 90504.167.200.006 (CC..0602..) 90504.182.200.006 (CC..0602..)
90504.142.250.000	25	29.5	40.1	170	90504.162.250.006 (CC..0602..) 90504.166.250.006 (CC..0602..) 90504.167.250.006 (CC..0602..) 90504.182.250.006 (CC..0602..)

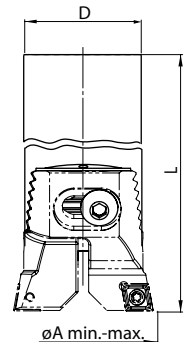

- with inner coolant supply
- mit Innenkühlung
- Clamp tool in a collet or hydraulic chuck.
- **Insert holder included**
- Werkzeug in einem Spannzangen- oder Hydrodehnfutter spannen.
- **Inklusive Wendeplattenhalter**

Spare parts / Accessories
Ersatzteile / Zubehör

90504.140/141/142/143

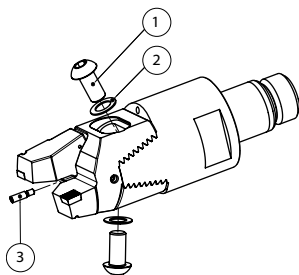

For twin cutter boring head/ Für Zweischneiderkopf	Part number/ Bestell-Nr.	Part number/ Bestell-Nr.	Part number/ Bestell-Nr.
	Fastening screw / Befestigungsschraube ①	Spring washer / Federring ②	Stopper / Anschlag ③
90504.140/141/142/143.200.000	90504.840.142.200	90504.841.142.200	90504.841.342.200
90504.140/141/142/143.250.000	90504.840.142.250	90504.841.142.250	90504.841.342.200
90504.140/141/142/143.320.000	90504.840.142.320	90504.841.142.320	90504.841.342.200
90504.140/141.420.000	90504.840.142.420	90504.841.142.420	90504.841.342.420
90504.140/141.550.000	90504.840.142.550	90504.841.142.550	90504.841.342.420
90504.140.720.000	90504.840.142.720	90504.841.142.720	90504.841.342.420
90504.140.940.000	90504.840.142.940	90504.841.142.940	90504.841.342.420

Fine boring head $\varnothing 9.75-88.1$

Ausdrehkopf $\varnothing 9,75-88.1$

90504.260

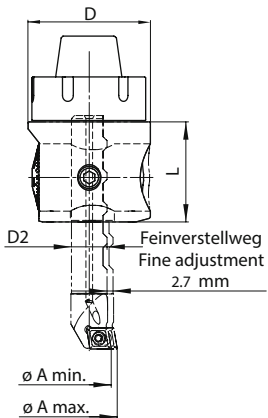

- diametrical adjustment with minimum reduced reversal backlash
- 0.01mm diametrical adjustment 0.002mm by vernier
- with internal coolant supply
- boring bars go through head
- DurchmesserEinstellung mit geringstem Umkehrspiel
- Zustellgenauigkeit von 0,01mm resp. über Nonius 0,002mm im Durchmesser
- mit Innenkühlung
- Ausdrehstäbe durchschiebbar

Part number/ Bestell-Nr.	D	d1	D2	$\varnothing A$ min.	$\varnothing A$ max.	L	L1	SW / AF
SMART ER32								
90504.262.032.060	55	-	16	9.75	88.1	60	91	-



Boring bars $\varnothing 9.75-30.1$

Ausdrehstäbe $\varnothing 9,75-30.1$

90504.272

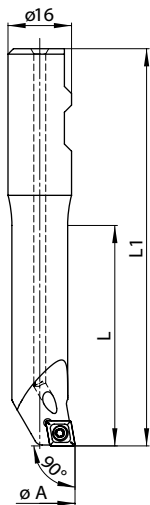

- with internal coolant supply
- if the boring bars are clamped centrally (weldon adapter), the minimum diameter ($\varnothing A$ min.) is provided
- mit Innenkühlung
- werden die Ausdrehstäbe zentrisch gespannt (Weldonfutter), kann mit $\varnothing A$ min. ausgedreht werden

Part number/ Bestell-Nr.	$\varnothing A$ min.	$\varnothing A$ max.	L	L1	Insert/ Wendeplatte
90504.272.010.006	9.75	15.1	30	75	CC..0602..
90504.272.012.006	11.75	17.1	37	80	CC..0602..
90504.272.014.006	13.75	19.1	43	85	CC..0602..
90504.272.015.006	14.75	20.1	51	90	CC..0602..
90504.272.016.006	15.75	21.1	57	95	CC..0602..
90504.272.018.006	17.75	23.1	67	100	CC..0602..
90504.272.020.006	19.75	25.1	72	105	CC..0602..
90504.272.025.006	24.75	30.1	82	115	CC..0602..

- length L stands for the maximal boring depth
- boring diameters $\varnothing A$ min. - A max. are only available with fine boring heads from series 90504.260-269
- Länge L bezeichnet die maximale Ausdrehlänge
- die Ausdrehdurchmesser $\varnothing A$ min. - A max. werden mit Ausdrehköpfen der Serien 90504.260-269 erreicht



Fine boring heads
Feinschlichtköpfe

Fine boring head Feinbohrkopf

90504.251

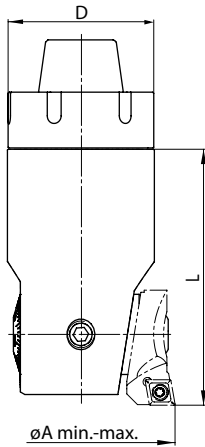

Bestell-Nr./ Order number	Ø D/ System	Ø A min.	Ø A max.	L	Insert holder/ Wendeplattenhalter
90504.251.320.000	32 / ER25	39.9	51.1	65	90504.254.320.006 (CC..0602..)
					90504.254.320.006 (CC..0602..)
		47.9	59.1		90504.254.321.006 (CC..0602..)
90504.251.420.000	42 / ER32	50.9	67.1	75	90504.254.420.006 (CC..0602..)
					90504.254.425.006 (CC..0602..)
		69.9	81.1		90504.254.421.006 (CC..0602..)
90504.251.550.000	55 / ER40	66.9	87.1	85	90504.254.550.006 (CC..0602..)
					90504.254.550.009 (CC..09T3..)
					90504.254.555.009 (CC..09T3..)
		84.9	105.1		90504.254.551.006 (CC..0602..)
					90504.254.551.009 (CC..09T3..)



• insert holder must be ordered separately

• Wendeplattenhalter müssen separat bestellt werden

Fine boring heads Feinbohrköpfe

90504.252

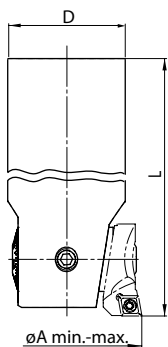

- diameter setting with minimal reversal backlash
- 0.01mm diametrical adjustment resp. 0.002mm by nonius
- with inner coolant supply

- DurchmesserEinstellung mit geringstem Umkehrspiel
- Zustellgenauigkeit von 0.01mm resp. über Nonius 0.002mm im Durchmesser
- mit Innenkühlung

Part number/ Bestell-Nr.	Ø D/ System	Ø A min.	Ø A max.	L	Insert holder / Wendeplattenhalter
90504.252.200.000	20	23.9	31.1	150	90504.254.200.006 (CC..0602..)
					90504.254.205.006 (CC..0602..)
		29.9	37.1		90504.254.201.006 (CC..0602..)
90504.252.250.000	25	30.9	40.1	170	90504.254.250.006 (CC..0602..)
					90504.254.255.006 (CC..0602..)
		37.9	47.1		90504.254.251.006 (CC..0602..)

- clamp tool in a collet or hydraulic chuck.
- insert holders must be ordered separately

- Werkzeug in einem Spannzangen- oder Hydrodehnfutter spannen.
- Wendeplattenhalter müssen separat bestellt werden



S C L C R 12 C A - 12

1

2

3

4





5







6







7

8

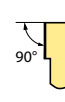
9

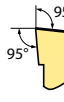
Spannsystem	
Code	Beschreibung
P	Kniehebel-Spannsystem 
M	Pratzen-/Pin-Spannsystem 
S	Schrauben-Spannsystem 
C	Pratzenklemmung 







Plattenform	
C	
D	
R	
S	
T	
V	



Halterform und Einstellwinkel			
			
F	G	K	L
			
R	S	T	W

1

2

3

Freiwinkel	
B	
C	
D	
E	
N	
P	

Schnittrichtung

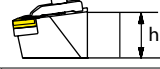

Schafthöhe h [mm]	
	
Code	h
6	6
8	8
10	10
12	12
16	16

Typ	
	
Code	Beschreibung
C	Kassettsystem







4

5

6

7

Haltertyp A
Nach ISO 5611

I.C [mm]	Schneidenlänge l [mm]					
	Plattenform					
						
	C	D	R	S	T	V
5,56					09	
6,35	06	07			11	
9,525	09	11	09	09	16	16
12,7	12	15	12	12	22	22
15,875	16	19	15	15	27	
19,05	19		19	19	33	
25,4	25		25	25	44	

8

9

ISO code Cartridges
ISO-Code Kurzklemmhalter

ISO-Code Cartridges EN

S C L C R 12 C A - 12

1

2

3

4





5

6







7

8









9

Clamping system	
Code	Description
P	Knee lever clamping 
M	Multi clamping 
S	Screw clamping 
C	Top clamping 







1

Insert shape	
C	
D	
R	
S	
T	
V	



2

Tool holder type and entering angle			
			
F	G	K	L
			
R	S	T	W

3

Clearance angle	
B 	C 
D 	E 
N 	P 

4

Cutting direction

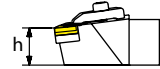

5

Shank height h [mm]	
	h
Code	h
6	6
8	8
10	10
12	12
16	16

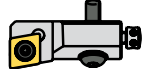





6

Type	
	
Code	Description
C	cassette system

7

Holder Type A
for ISO 5611

8

Cutting edge length l [mm]						
I.C [mm]	Insert shape					
						
	C	D	R	S	T	V
5,56	09					
6,35	06	07	11			
9,525	09	11	09	09	16	16
12,7	12	15	12	12	22	22
15,875	16	19	15	15	27	
19,05	19		19	19	33	
25,4	25		25	25	44	

9

KR= 95° Cartridges/ Kurzklemmhalter

SCLCR/L

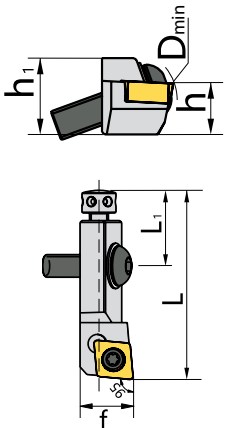

• cartridges for tailor made tools

• Zur Verwendung in Sonderwerkzeugen

Part number/ Bestell-Nr.	Insert WSP	Dimension Abmessung					
		h	f	L	h ₁	L ₁	D _{min}
SCLCR-10CA-09	CC..09T3..	10	14	50	15	20	40
SCLCL-10CA-09	CC..09T3..	10	14	50	15	20	40
SCLCR-12CA-12	CC..1204..	12	20	55	20	20	50
SCLCL-12CA-12	CC..1204..	12	20	55	20	20	50



Spare parts / Accessories

Ersatzteile / Zubehör

SCLCR/L

Size/ Größe	Sleeve/ Hülse ①	radial adjusting screw/ radiale Einstell- schraube ②	Wrench/ Schlüssel ②	Screw/ Schraube ③	axial adju- sting screw/ axiale Anstell- schraube ④	Wrench/ Schlüssel ④	Washer / Unterleg- scheibe ⑤	Screw for Insert/ Schraube für WSP ⑥	Wrench/ Schlüssel ⑥
10CA	LT-M5	RSM4x8	WH20L	M6x20	ASM5x14	WH40L	P-M6	I60M3.5x8	WT15IP
12CA	LT-M5	RSM4x12	WH20L	M6x25	ASM5x14	WH40L	P-M6	I60M4x11X	WT15IP

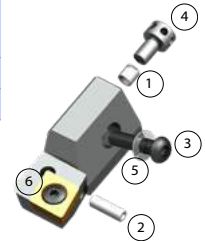

KR= 90° Cartridges/ Kurzklemmhalter

SCFCR/L

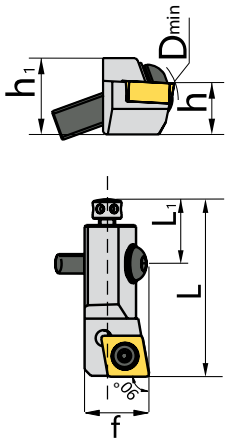

• cartridges for tailor made tools

• Zur Verwendung in Sonderwerkzeugen

Part number/ Bestell-Nr.	Insert WSP	Dimension Abmessung					
		h	f	L	h ₁	L ₁	D _{min}
SCFCR-10CA-09	CC..09T3..	10	14	50	15	20	40
SCFCL-10CA-09	CC..09T3..	10	14	50	15	20	40
SCFCR-12CA-12	CC..1204..	12	20	55	20	20	50
SCFCL-12CA-12	CC..1204..	12	20	55	20	20	50



Spare parts / Accessories

Ersatzteile / Zubehör

SCFCR/L

Size/ Größe	Sleeve/ Hülse ①	radial adjusting screw/ radiale Einstell- schraube ②	Wrench/ Schlüssel ②	Screw/ Schraube ③	axial adju- sting screw/ axiale Anstell- schraube ④	Wrench/ Schlüssel ④	Washer / Unterleg- scheibe ⑤	Screw for Insert/ Schraube für WSP ⑥	Wrench/ Schlüssel ⑥
10CA	LT-M5	RSM4x8	WH20L	M6x20	ASM5x14	WH40L	P-M6	I60M3.5x8	WT15IP
12CA	LT-M5	RSM4x12	WH20L	M6x25	ASM5x14	WH40L	P-M6	I60M4x11X	WT15IP

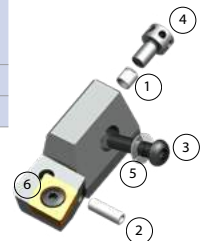

Cartridges Kurzklemmhalter

KR=90° Cartridges/ Kurzklemmhalter

STGCR/L

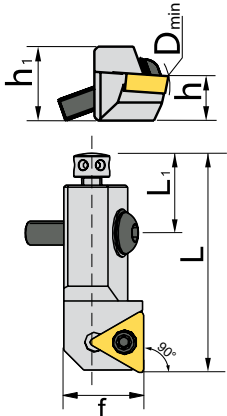

• cartridges for tailor made tools

• Zur Verwendung in Sonderwerkzeugen

Part number/ Bestell-Nr.	Insert WSP	Dimension Abmessung					
		h	f	L	h ₁	L ₁	D _{min}
STGCR-10CA-11	TC..1103..	10	14	50	15	20	40
STGCL-10CA-11	TC..1103..	10	14	50	15	20	40
STGCR-12CA-16	TC..16T3..	12	20	55	20	20	50
STGCL-12CA-16	TC..16T3..	12	20	55	20	20	50



Spare parts / Accessories

Ersatzteile / Zubehör

STGCR/L

Size/ Größe	Sleeve/ Hülse ①	radial adjusting screw/ radiale Einstell- schraube ②	Wrench/ Schlüssel ②	Screw/ Schraube ③	axial adju- sting screw/ axiale Anstell- schraube ④	Wrench/ Schlüssel ④	Washer / Unterleg- scheibe ⑤	Screw for Insert/ Schraube für WSP ⑥	Wrench/ Schlüssel ⑥
10CA	LT-M5	RSM4x8	WH20L	M6x20	ASM5x14	WH40L	P-M6	I60M3.5x8	WT15IP
12CA	LT-M5	RSM4x12	WH20L	M6x25	ASM5x14	WH40L	P-M6	I60M4x11X	WT15IP

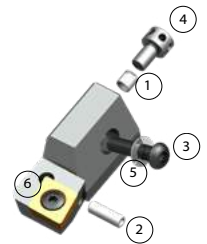

KR= 75° Cartridges/ Kurzklemmhalter

SSKCR/L

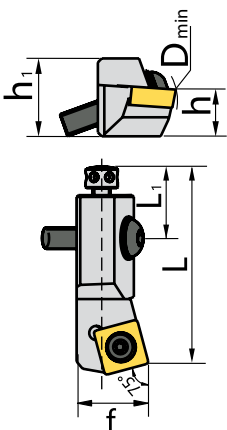

• cartridges for tailor made tools

• Zur Verwendung in Sonderwerkzeugen

Part number/ Bestell-Nr.	Insert WSP	Dimension Abmessung					
		h	f	L	h ₁	L ₁	D _{min}
SSKCL12CA12	SC..1204..	12	20	55	20	20	50
SSKCL16CA12	SC..1204..	12	20	55	20	20	50
SSKCR12CA12	SC..1204..	16	25	63	21	25	55
SSKCR16CA12	SC..1204..	16	25	63	21	25	55



Spare parts / Accessories

Ersatzteile / Zubehör

SSKCR/L

Size/ Größe	Sleeve/ Hülse ①	radial adjusting screw/ radiale Einstell- schraube ②	Wrench/ Schlüssel ②	Screw/ Schraube ③	axial adju- sting screw/ axiale Anstell- schraube ④	Wrench/ Schlüssel ④	Washer / Unterleg- scheibe ⑤	Screw for Insert/ Schraube für WSP ⑥	Wrench/ Schlüssel ⑥
12CA	LT-M5	RSM4x12	WH20L	M6x25	ASM5x14	WH40L	P-M6	I60M4x11X	WT15IP
16CA	LT-M6	RSM4x12	WH25L	M6x25	ASM6x18	WH50L	P-M8	I60M4x11X	WT15IP

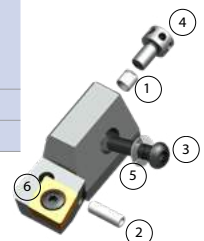

KR= 45° Cartridges/ Kurzklemmhalter

SSRCR/L

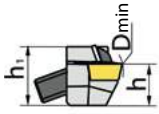

• cartridges for tailor made tools

• Zur Verwendung in Sonderwerkzeugen

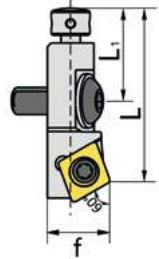

Part number/ Bestell-Nr.	Insert WSP	Dimension Abmessung					
		h	f	L	h ₁	L ₁	D _{min}
SSRCR-10CA-09	SC..09T3..	10	14	44	15	20	40
SSRCL-10CA-09	SC..09T3..	10	14	44	15	20	40
SSRCR-12CA-12	SC..1204..	12	20	47	20	20	50
SSRCL-12CA-12	SC..1204..	12	20	47	20	20	50



Spare parts / Accessories

Ersatzteile / Zubehör

SSRCR/L

Size/ Größe	Sleeve/ Hülse ①	radial adjusting screw/ radiale Einstell- schraube ②	Wrench/ Schlüssel ②	Screw/ Schraube ③	axial adju- sting screw/ axiale Anstell- schraube ④	Wrench/ Schlüssel ④	Washer / Unterleg- scheibe ⑤	Screw for Insert/ Schraube für WSP ⑥	Wrench/ Schlüssel ⑥
10CA	LT-M5	RSM4x8	WH20L	M6x20	ASM5x14	WH40L	P-M6	I60M3.5x8	WT15IP
12CA	LT-M5	RSM4x12	WH20L	M6x25	ASM5x14	WH40L	P-M6	I60M5x13	WT20IP

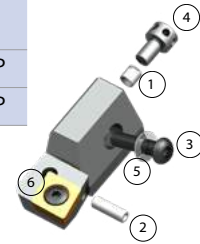

Cartridges
Kurzklemmhalter

KR= 60° Cartridges/ Kurzklemmhalter

STTCR/L

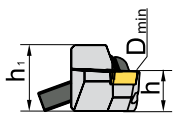

• cartridges for tailor made tools

• Zur Verwendung in Sonderwerkzeugen

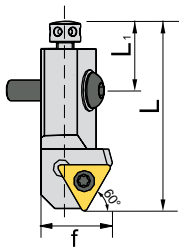

Part number/ Bestell-Nr.	Insert WSP	Dimension Abmessung					
		h	f	L	h ₁	L ₁	D _{min}
STTCR-10CA-11	TC..1103..	10	9	50	15	20	40
STTCL-10CA-11	TC..1103..	10	9	50	15	20	40
STTCR-12CA-16	TC..16T3..	12	13	55	20	20	50
STTCL-12CA-16	TC..16T3..	12	13	55	20	20	50



Spare parts / Accessories

Ersatzteile / Zubehör

STTCR/L

Size/ Größe	Sleeve/ Hülse ①	radial adjusting screw/ radiale Einstell- schraube ②	Wrench/ Schlüssel ②	Screw/ Schraube ③	axial adju- sting screw/ axiale Anstell- schraube ④	Wrench/ Schlüssel ④	Washer / Unterleg- scheibe ⑤	Screw for Insert/ Schraube für WSP ⑥	Wrench/ Schlüssel ⑥
10CA	LT-M5	RSM4x8	WH20L	M6x20	ASM5x14	WH40L	P-M6	I60M2,5x6,5	WT07IP
12CA	LT-M5	RSM4x12	WH20L	M6x25	ASM5x14	WH40L	P-M6	I60M4x8,4	WT20IP

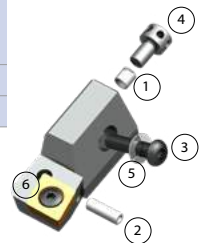

Cartridges Kurzklemmhalter

Round-insert/Rundplatte Cartridges/ Kurzklemmhalter

SRSCR/L

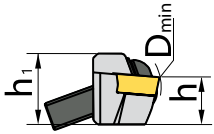

• cartridges for tailor made tools

• Zur Verwendung in Sonderwerkzeugen

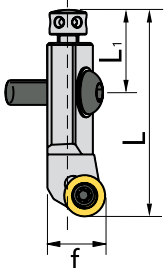

Part number/ Bestell-Nr.	Insert WSP	Dimension Abmessung					
		h	f	L	h ₁	L ₁	D _{min}
SRSCR-10CA-10	RC..10T3	10	14	44	15	20	40
SRSCL-10CA-10	RC..10T3	10	14	44	15	20	40
SRSCR-12CA-12	RC..1204	12	20	47	20	20	50
SRSCL-12CA-12	RC..1204	12	20	47	20	20	50



Spare parts / Accessories

Ersatzteile / Zubehör

SRSCR/L

Size/ Größe	Sleeve/ Hülse ①	radial adjusting screw/ radiale Einstell- schraube ②	Wrench/ Schlüssel ②	Screw/ Schraube ③	axial adjusting screw/ axiale Anstell- schraube ④	Wrench/ Schlüssel ④	Washer / Unterleg- scheibe ⑤	Screw for Insert/ Schraube für WSP ⑥	Wrench/ Schlüssel ⑥
10CA	LT-M5	RSM4x8	WH20L	M6x20	ASM5x14	WH40L	P-M6	I60M3.5x10	WT15IP
12CA	LT-M5	RSM4x12	WH20L	M6x25	ASM5x14	WH40L	P-M6	I60M3.5x10.4	WT20IP

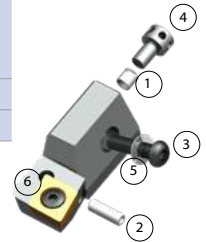

Blank/Rohling Cartridges/ Kurzklemmhalter

A-**CA

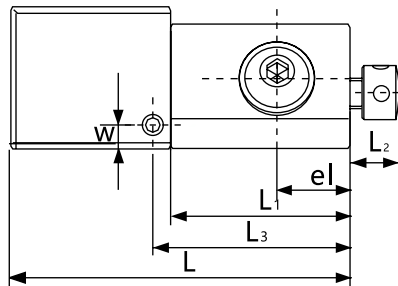
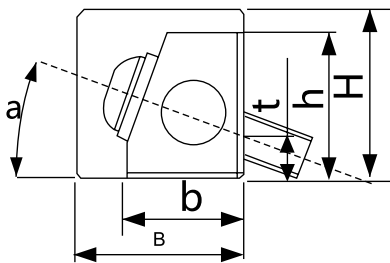

Schnittstelle der Kassete wird nach ISO5611 konzipiert, Plattensitz kann nach Kundenanforderung individuell angefertigt werden. Dieses System bietet dem Kunden Lösungen nach Maß an.

Part number/ Bestell-Nr.	Dimension Abmessung									
	h	t	b	a	L ₂	e ₁	L ₁	L ₂	L	W
A-06CA	8,5	3,5	6	20	4,5	12	16	18	25	2,2
A-08CA	11	4,5	8	20	6	17	22	24,2	32	2,5
A-10CA	15	5	11	20	8	20	35	38	53	3,5
A-12CA	20	6	16	20	8	20	37	40	63	4
A-16CA	25	0	20	45	8	25	37	48	63	5

Size/ Größe	Sleeve/ Hülse ①	radial adjusting screw/ Radiale Einstell- schraube ②	Wrench/ Schlüssel ②	Screw/ Schraube ③	Axial adjusting screw/ Axiale Anstell- schraube ④	Wrench/ Schlüssel ④	Washer / Unterleg- scheibe ⑤
06CA	LT-M3	RSM3x6	WH15L	M3.5x10	ASM3x9	WH20L	P-M3.5
08CA	LT-M4	RSM3x6	WH15L	M4x14	ASM4x12	WH25L	P-M4
10CA	LT-M5	RSM4x8	WH20L	M6x20	ASM5x14	WH40L	P-M6
12CA	LT-M5	RSM4x12	WH20L	M6x25	ASM5x14	WH40L	P-M6
16CA	LT-M6	RSM5x16	WH25L	M8x30	ASM6x18	WH50L	P-M8

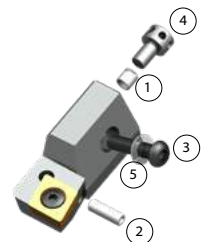

Insert suggestions finishing WSP-Empfehlung Schlichten

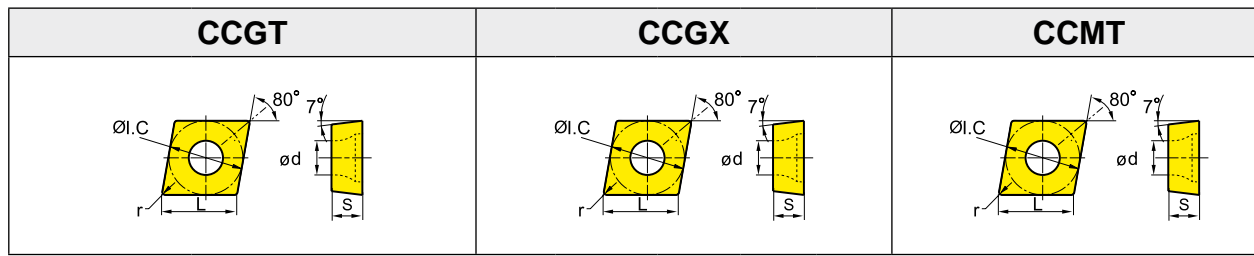

Insert shape Plattenform	Type / Typ	Dimensions / Abmessung					Additional information Zusätzliche Informationen
		L	I.C	s	d	r	
	CCGT060202-L	6,4	6,35	2,38	2,8	0,2	Periphery ground inserts, ground chip groove/polished Wendeplatte umfangsgeschliffen, Spanleitstufe geschliffen/poliert
	CCGT09T302-L	9,7	9,525	3,97	4,4	0,2	
	CCGT09T304-L	9,7	9,525	3,97	4,4	0,4	
	CCGT09T302L-USF	9.7	9.525	4.38	4.4	0.2	Periphery ground inserts, ground chip groove Wendeplatte umfangsgeschliffen, Spanleitstufe geschliffen
	CCGT09T304L-USF	9.7	9.525	5.38	4.4	0.4	
	CCGX060202-LC	6.4	6.35	2.38	2.8	0.2	Periphery ground insert chip groove pressed Wendeplatte umfangsgeschliffen, Spanleitstufe gepresst
	CCGX060204-LC	6.4	6.35	2.38	2.8	0.4	
	CCGX09T304-LC	9.7	9.525	3.97	4.4	0.4	
	CCGX060202-LH	6.4	6.35	2.38	2.8	0.2	Periphery ground insert chip groove pressed Wendeplatte umfangsgeschliffen, Spanleitstufe gepresst
	CCGX060204-LH	6.4	6.35	2.38	2.8	0.4	
	CCGX09T304-LH	9.7	9.525	3.97	4.4	0.4	
	CCGT060202-SF	6.4	6.35	2.38	2.8	0.2	Periphery ground insert, chip groove pressed Wendeplatte umfangsgeschliffen, Spanleitstufe gepresst
	CCGT060204-SF	6.4	6.35	2.38	2.8	0.4	
	CCGT09T304-SF	9.7	9.525	3.97	4.4	0.4	
	CCGT120404-SF	12.9	12.7	4.76	5.56	0.4	
	CCMT060202-EF	6.4	6.35	2.38	2.8	0.2	Insert pressed, chip groove pressed Wendeplatte gepresst, Spanleitstufe gepresst
	CCMT060204-EF	6.4	6.35	2.38	2.8	0.4	
	CCMT09T304-EF	9.7	9.525	3.97	4.4	0.4	
	CCMT120404-EF	12.9	12.7	4.76	5.56	0.4	Insert pressed, chip groove pressed / Wendeplatte gepresst, Spanleitstufe gepresst
	CCMT060202-EF	6.4	6.35	2.38	2.8	0.2	
	CCMT120404-EF	12.9	12.7	4.76	5.56	0.4	
	CCMT060202-HF	6.4	6.35	2.38	2.8	0.2	Insert pressed, chip groove pressed / Wendeplatte gepresst, Spanleitstufe gepresst
	CCMT120404-HF	12.9	12.7	4.76	5.56	0.4	

Insert sharpness / Schneidplattenschärfe

Cutting edge stability / Schneidkantenstabilität

Insert suggestion finishing
WS-Empfehlung Schlichten

Insert suggestion finishing WSP-Empfehlung Schlichten

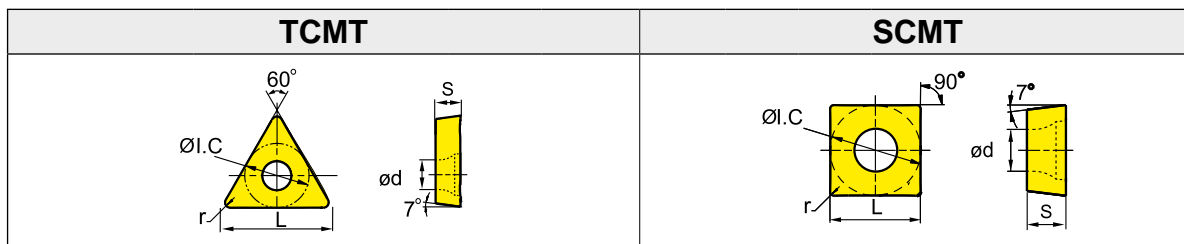

Insert shape/ Plattenform	Type / Typ	Dimensions / Abmessung					Additional information/ Zusätzliche Informationen
		L	I.C	s	d	r	
	TCMT110204-EF	11	6.35	2.38	2.8	0.4	Insert pressed, chip groove pressed Wendepatte gepresst, Spanleitstufe gepresst
	TCMT110208-EF	11	6.35	2.38	2.8	0.8	
	TCMT16T304-EF	16.5	9.525	3.97	4.4	0.4	
	TCMT16T308-EF	16.5	9.525	3.97	4.4	0.8	
	TCMT110208-HF	11	6.35	2.38	2.8	0.8	Insert pressed, chip groove pressed Wendepatte gepresst, Spanleitstufe gepresst
	TCMT110208-HF	11	6.35	2.38	2.8	0.8	
	TCMT16T304-HF	16.5	9.525	3.97	4.4	0.4	
	TCMT16T308-HF	16.5	9.525	3.97	4.4	0.8	
	TCMT110204-AHF	11	6.35	2.38	2.8	0.4	Insert pressed, chip groove pressed Wendepatte gepresst, Spanleitstufe gepresst
	TCMT110208-AHF	11	6.35	2.38	2.8	0.8	
	TCMT16T304-AHF	16.5	9.525	3.97	4.4	0.4	
	TCMT16T308-AHF	16.5	9.525	3.97	4.4	0.8	
	SCMT09T304-EF	9.525	9.525	3.97	4.4	0.4	Insert pressed, chip groove pressed Wendepatte gepresst, Spanleitstufe gepresst
	SCMT09T308-EF	9.525	9.525	3.97	4.4	0.8	
	SCMT09T304-HF	9.525	9.525	3.97	4.4	0.4	Insert pressed, chip groove pressed Wendepatte gepresst, Spanleitstufe gepresst
	SCMT09T308-HF	9.525	9.525	3.97	4.4	0.8	
	SCMT09T304-HF	9.525	9.525	3.97	4.4	0.4	
	SCMT09T308-HF	9.525	9.525	3.97	4.4	0.8	

Insert sharpness / Schneidplattenschärfe

Cutting edge stability / Schneidkantenstabilität

Cutting speed data finishing Schnittdatenempfehlungen Schlichten

					Feed rate in mm per revolution related to cutting edge radius/ <i>Vorschub fz in mm pro Umdrehung bezogen auf Schneidkantenradius</i>	
ISO Group / ISO Gruppe	Workpiece material/ <i>Werkstoff</i>	Tensile strenght [N/mm ²]/ <i>Zugfestigkeit [N/mm²]</i>	Cutting material / <i>Schneidstoff</i>	Cutting speed Vc [m/min] / <i>Schnittgeschwindigkeit Vc [m/min]</i>	Cutting edge radius/ <i>Schneidkantenradius</i> 0,2 mm Cutting depth/ <i>Schnitttiefe</i> ap = 0,1 - 0,25 mm	Cutting edge radius/ <i>Schneidkantenradius</i> 0,4 mm Cutting depth/ <i>Schnitttiefe</i> ap = 0,2 - 0,45 mm
P	Unalloyed steel/ <i>Unlegierter Stahl</i>	<600N/mm ²	YBG205/ YBC152/ YBC252	140-250	0,04-0,08	0,1-0,16
		>600N/mm ²	YBG205/ YBC152/ YBC252	125-220	0,04-0,08	0,1-0,16
	Alloyed steel & cast steel/ <i>Legierter Stahl & Stahlguss</i>	<900N/mm ²	YBG205/ YBC152/ YBC252	125-220	0,04-0,08	0,1-0,16
		>900N/mm ²	YBG205/ YBC152/ YBC252	110-180	0,04-0,08	0,1-0,16
	High alloy steel/ <i>Hochlegierter Stahl</i>	<1000N/mm ²	YBG205/ YBC152/ YBC252	110-150	0,04-0,08	0,1-0,16
		>1000N/mm ²	YBG205/ YBC152/ YBC252	90-130	0,04-0,08	0,1-0,16
M	Stainless steels (ferretic/martensetic)/ <i>Nichtrostende Materialien (ferritisch/martensitisch)</i>		YBG205/ YBM153/ YBM253	80-120	0,04-0,08	0,1-0,16
	Stainless steels (austenitic)/ <i>Nichtrostende Materialien (austenitisch)</i>		YBM153/ YBM253/ YBG205	75-120	0,04-0,08	0,1-0,16
K	GTW, GTS/ <i>Temperguss</i>		YBG205/ YBD152	150-240	0,04-0,08	0,1-0,16
	GGL,GJL		YBG205/ YBD152	150-240	0,04-0,08	0,1-0,16
	GJS		YBG205/ YBD152	150-200	0,04-0,08	0,1-0,16
N	Aluminium alloys / <i>Aluminiumlegierung</i>		YD101	100-800	0,04-0,08	0,1-0,16
S	Inconell, Hastelloy		YBG205	40-120	0,04-0,08	0,1-0,16
	Titanium and titanium alloys / <i>Titan und Titanlegierungen</i>		YBG205	40-100	0,04-0,08	0,1-0,16

 Insert suggestion finishing
WS-Empfehlungen Schlichten

Insert suggestion roughing WSP-Empfehlungen schrappen

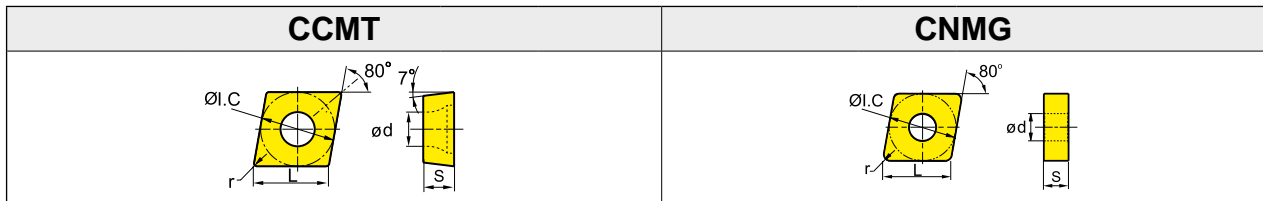

Insert shape/ Plattenform	Type / Typ	Dimensions / Abmessung					Additional information/ Zusätzliche Informationen
		L	I.C	s	d	r	
	CCMT060204-EM	6.4	6.35	2.38	2.8	0.4	Insert pressed, chip groove pressed Wendeplatte gepresst, Spanleitstufe gepresst
	CCMT09T304-EM	9.7	9.525	3.97	4.4	0.4	
	CCMT120404-EM	12.9	12.7	4.76	5.56	0.4	
	CCMT120408-EM	12.9	12.7	4.76	5.56	0.8	
	CCMT060204-HM	6.4	6.35	2.38	2.8	0.4	Insert pressed, chip groove pressed Wendeplatte gepresst, Spanleitstufe gepresst
	CCMT09T304-HM	9.7	9.525	3.97	4.4	0.4	
	CCMT120404-HM	12.9	12.7	4.76	5.56	0.4	
	CCMT060204-HR	6.4	6.35	2.38	2.8	0.4	Insert pressed, chip groove pressed Wendeplatte gepresst, Spanleitstufe gepresst
	CCMT09T304-HR	9.7	9.525	3.97	4.4	0.4	
	CCMT120408-HR	12.9	12.7	4.76	5.56	0.8	
	CCMT120404-TC	12.9	12.7	4.76	5.16	0.4	Insert pressed, chip groove pressed Wendeplatte gepresst, Spanleitstufe gepresst
	CCMT120408-TC	12.9	12.7	4.76	5.16	0.8	
	CNMG120404-TC	12.9	12.7	4.76	5.16	0.4	
	CNMG120408-TC	12.9	12.7	4.76	5.16	0.8	
	CNMG120408-EM	12.9	12.7	4.76	5.16	0.8	Insert pressed, chip groove pressed Wendeplatte gepresst, Spanleitstufe gepresst
	CNMG160608-EM	16.1	15.875	6.35	6.35	0.8	
	CNMG120408-DM	12.9	12.7	4.76	5.16	0.8	Insert pressed, chip groove pressed Wendeplatte gepresst, Spanleitstufe gepresst
	CNMG160608-DM	16.1	15.875	6.35	6.35	0.8	
	CNMG120408-PM	12.9	12.7	4.76	5.16	0.8	Insert pressed, chip groove pressed Wendeplatte gepresst, Spanleitstufe gepresst
	CNMG160608-PM	16.1	15.875	6.35	6.35	0.8	

Insert sharpness / Schneidplattenschärfe

Cutting edge stability / Schneidkantenstabilität

Insert suggestion roughing
WS-Empfehlungen schrappen

Insert suggestions roughing WSP-Empfehlung schrappen

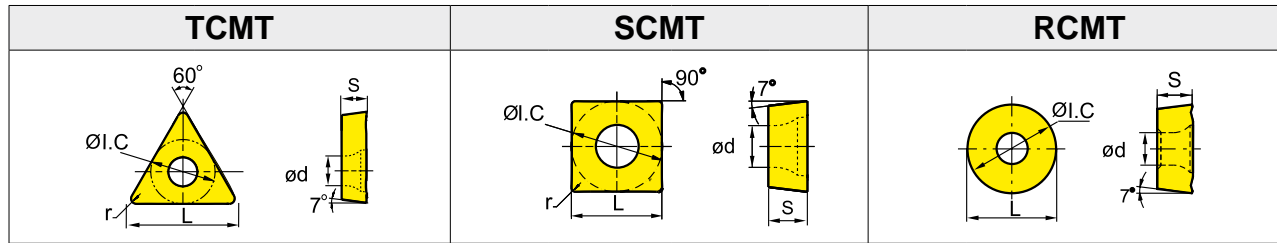

Insert shape/ Plattenform	Type / Typ	Dimensions / Abmessung					Additional information/ Zusätzliche Informationen
		L	I.C	s	d	r	
	TCMT110204-EM	11	6.35	2.38	2.8	0.4	Insert pressed, chip groove pressed
	TCMT110208-EM	11	6.35	2.38	2.8	0.8	Wendeplatte gepresst, Spanleitstufe gepresst
	TCMT16T304-EM	16.5	9.525	3.97	4.4	0.4	
	TCMT16T308-EM	16.5	9.525	3.97	4.4	0.8	Insert pressed, chip groove pressed Wendeplatte gepresst, Spanleitstufe gepresst
	TCMT110204-HM	11	6.35	2.38	2.8	0.4	
	TCMT110208-HM	11	6.35	2.38	2.8	0.8	
	TCMT16T304-HM	16.5	9.525	3.97	4.4	0.4	Insert pressed, chip groove pressed
	TCMT16T308-HM	16.5	9.525	3.97	4.4	0.8	Wendeplatte gepresst, Spanleitstufe gepresst
	TCMT110204-HR	11	6.35	2.38	2.8	0.4	
	TCMT110208-HR	11	6.35	2.38	2.8	0.8	Insert pressed, chip groove pressed
	TCMT16T304-HR	16.5	9.525	3.97	4.4	0.4	Wendeplatte gepresst, Spanleitstufe gepresst
	TCMT16T308-HR	16.5	9.525	3.97	4.4	0.8	
	SCMT09T304-EM	9.525	9.525	3.97	4.4	0.4	Insert pressed, chip groove pressed
	SCMT09T308-EM	9.525	9.525	3.97	4.4	0.8	Wendeplatte gepresst, Spanleitstufe gepresst
	SCMT120404-EM	12.7	12.7	4.76	5.56	0.4	
	SCMT120408-EM	12.7	12.7	4.76	5.56	0.8	
	SCMT120412-EM	12.7	12.7	4.76	5.56	1.2	Insert pressed, chip groove pressed
	SCMT09T304-HM	9.525	9.525	3.97	4.4	0.4	Wendeplatte gepresst, Spanleitstufe gepresst
	SCMT09T308-HM	9.525	9.525	3.97	4.4	0.8	
	SCMT120404-HM	12.7	12.7	4.76	5.56	0.4	Insert pressed, chip groove pressed
	SCMT120408-HM	12.7	12.7	4.76	5.56	0.8	Wendeplatte gepresst, Spanleitstufe gepresst
	SCMT120412-HM	12.7	12.7	4.76	5.56	1.2	
	SCMT09T304-HR	9.525	9.525	3.97	4.4	0.4	
	SCMT09T308-HR	9.525	9.525	3.97	4.4	0.8	Insert pressed, chip groove pressed
	SCMT120404-HR	12.7	12.7	4.76	5.56	0.4	Wendeplatte gepresst, Spanleitstufe gepresst
	SCMT120408-HR	12.7	12.7	4.76	5.56	0.8	
	SCMT120412-HR	12.7	12.7	4.76	5.56	1.2	
	RCMT10T3MO-DM	10	10	3.97	3.6		Insert pressed, chip groove pressed
	RCMT10T3MO	10	10	3.97	3.6		Wendeplatte gepresst, Spanleitstufe gepresst

Insert sharpness / Schneidkantenstärke

Cutting edge stability / Schneidkantenstabilität

Insert suggestion roughing
WS-Empfehlung schrappen

Cutting speed data roughing Schnittdatenempfehlungen Schruppbearbeitung

					Feed rate in mm per revolution related to cutting edge radius and boring range / <i>Vorschub fz in mm pro Umdrehung bezogen auf Schneidkantenradius und Ausdrehbereich</i>		
ISO Group / ISO Gruppe	Workpiece material/ Werkstoff	Tensile strength [N/mm ²]/ Zugfestigkeit [N/mm ²]	Cutting material/ Schneidstoff	Cutting speed Vc [m/min]/ Schnittgeschwindigkeit Vc [m/min]	Cutting edge radius/ Schneidkantenradius 0,2 mm Boring range/ Ausdrehbereich 23,5-40,1 mm	Cutting edge radius/ Schneidkantenradius 0,4 mm Boring range/ Ausdrehbereich 29,5-66,5 mm	Cutting edge radius/ Schneidkantenradius 0,8 mm Boring range/ Ausdrehbereich 65,5-402 mm
P					Cutting depth/ Schnitttiefe ap = 1,0-2,5 mm	Cutting depth/ Schnitttiefe ap = 1,5-3,5 mm	Cutting depth/ Schnitttiefe ap = 2,5-5,0 mm
	Unalloyed steel/ Unlegierter Stahl	<600N/mm ²	YBC152/ YBC252	110-250	0,08-0,13	0,18-0,25	0,25-0,4
		>600N/mm ²	YBC152/ YBC252	110-220	0,08-0,13	0,18-0,25	0,25-0,4
					Cutting depth/ Schnitttiefe ap = 1,0-2,5 mm	Cutting depth/ Schnitttiefe ap = 1,5-3,5 mm	Cutting depth/ Schnitttiefe ap = 2,5-5,0 mm
	Alloyed steel & cast steel/ Legierter Stahl & Stahlguss	<900N/mm ²	YBC152/ YBC252	100-160	0,08-0,13	0,18-0,25	0,25-0,4
		>900N/mm ²	YBC152/ YBC252	90-150	0,08-0,13	0,18-0,25	0,25-0,4
					Cutting depth/ Schnitttiefe ap = 0,75-2,3 mm	Cutting depth/ Schnitttiefe ap = 1,5-3,5 mm	Cutting depth/ Schnitttiefe ap = 2,5-5,0 mm
	High alloy steel/ Hochlegierter Stahl	<1000N/mm ²	YBC152/ YBC252	80-140	0,08-0,13	0,18-0,25	0,25-0,4
>1000N/mm ²		YBC152/ YBC252	90-130	0,08-0,13	0,18-0,25	0,25-0,4	
M					Cutting depth/ Schnitttiefe ap = 0,75-2,0 mm	Cutting depth/ Schnitttiefe ap = 1,0-3,0 mm	Cutting depth/ Schnitttiefe ap = 2,5-4,0 mm
	Stainless steels (ferritic/martensitic)/ nichtrostende Materialien (ferritisch/ martensitisch)		YBM153/ YBM253/ YBG205	80-120	0,08-0,13	0,18-0,25	0,25-0,4
	Stainless steels (austenitic)/ nichtrostende Materialien (austenitisch)		YBM153/ YBM253/ YBG205	75-120	0,08-0,13	0,18-0,25	0,25-0,4
K					Cutting depth/ Schnitttiefe ap = 1,0-2,5 mm	Cutting depth/ Schnitttiefe ap = 2,5-3,5 mm	Cutting depth/ Schnitttiefe ap = 3,5-5,0 mm
	GTS, GTW/ Temperguss		YBD152C/ YBD152	150-200	0,08-0,13	0,18-0,25	0,25-0,4
	GGL, GJL		YBD152C/ YBD152	150-200	0,08-0,13	0,18-0,25	0,25-0,4
	GJS		YBD152C/ YBD152	120-180	0,08-0,13	0,18-0,25	0,25-0,4
N					Cutting depth/ Schnitttiefe ap = 1,0-2,0 mm	Cutting depth/ Schnitttiefe ap = 2,5-4,0 mm	Cutting depth/ Schnitttiefe ap = 4,0-6,0 mm
	Aluminium alloys/ Aluminiumlegierung		YD101	100-360	0,08-0,13	0,18-0,25	0,25-0,4
S					Cutting Depth/ Schnitttiefe ap = 0,4-0,8 mm	Cutting Depth/ Schnitttiefe ap = 0,8-1,5 mm	Cutting Depth/ Schnitttiefe ap = 1,5-1,8 mm
	Inconell, Hastelloy		YBG205	35-55	0,08-0,13	0,18-0,25	0,25-0,4
	Titanium and titanium alloys/ Titan und Titanlegierungen		YBG205	40-80	0,08-0,13	0,18-0,25	0,25-0,4

Cutting data
Schnittdatenempfehlung

Substrate information

Substratinformation

<p>YBC152 P05 – 20</p>	<p>Thick TiCN and thick Al₂O₃ coatings improve the impact toughness and abrasion resistance, which makes it suitable for finishing and semi-finishing of steel at high speed conditions. Cutting speed can be increased by more than 25 % against the first generation, while the tool life can be increased by more than 30 % at the same cutting speed.</p> <p><i>Dicke TiCN und Al₂O₃ Beschichtung verbessern die Schlagzähigkeit und Abriebbeständigkeit. Die Sorte eignet sich somit für die Endbearbeitung und mittlere Bearbeitung von Stahl mit hohen Geschwindigkeiten. Die Schnittgeschwindigkeit kann um mehr als 25 % gegenüber der Vorgängersorte gesteigert werden, während sich die Werkzeugstandzeit bei gleicher Schnittgeschwindigkeit um mehr als 30 % erhöhen kann.</i></p>
<p>YBC252 P10 – P35</p>	<p>Consists of thick TiCN and thick Al₂O₃ coating, the grade has a high capability against plastic deformation and a hard cutting edge. Preferred grade for machining of steel from finishing to roughing. Under the same cutting conditions, the cutting speed can be increased by more than 25 % against the first generation, while the tool life can last 30 % longer under the same cutting speed.</p> <p><i>Bestehend aus dicker TiCN- und dicker Al₂O₃-Beschichtung. Gute Eigenschaften gegen plastische Verformung bei gleichzeitig hoher Härte. Bevorzugte Sorte für die Bearbeitung von Stahl, Schlicht- bis Schruppbearbeitung. Schnittgeschwindigkeit kann um mehr als 25 % erhöht werden gegenüber der ersten Generation, während die Standzeit bei gleicher Schnittgeschwindigkeit um 30 % verlängert werden kann.</i></p>
<p>YNT251 P10 – 30</p>	<p>Nano composite powder material, controlled ring structure and strengthened binder phase give the material outstanding wear resistance and toughness with longer service life and stability. Perfect Ta/Nb proportion combined with high N content gives excellent hardness.</p> <p><i>Nano-Composite-Pulver-Material, kontrollierte Ringstruktur und verstärkte Bindemittelphase geben dem Material hervorragende Verschleißfestigkeit und Zähigkeit mit längerer Lebensdauer und Stabilität. Perfektes Ta/Nb-Verhältnis kombiniert mit hohem N-Gehalt ergibt eine ausgezeichnete Härte.</i></p>
<p>YBM153 M05 – M30</p>	<p>Thick TiCN and thick Al₂O₃ coating improves the impact toughness, abrasion resistance and temperature resistance. Suitable for finishing and semi-finishing of stainless steel. Cutting speed can be increased by more than 25 % against the first generation, while tool life can be increased by more than 35 % at the same cutting speed.</p> <p><i>Dicke TiCN und dicke Al₂O₃ Beschichtung verbessern die Schlagzähigkeit, Abriebbeständigkeit und Temperaturbeständigkeit. Eignet sich somit für die Endbearbeitung und mittlere Bearbeitung von nichtrostendem Stahl. Die Schnittgeschwindigkeit kann um mehr als 25 % gegenüber der Vorgängersorte gesteigert werden, während sich die Werkzeugstandzeit bei gleicher Schnittgeschwindigkeit um mehr als 35 % erhöhen kann.</i></p>
<p>YBM253 M10 – M35</p>	<p>Consists of thick TiCN and thick Al₂O₃ coating, the grade has a high capability against plastic deformation, good hardness and temperature resistance of cutting edge. It is the preferred grade for machining of stainless steel from finishing to roughing. Under the same cutting conditions, the cutting speed can be increased by more than 25 % against the first generation, while the tool life can be 30 % longer under the same cutting speed.</p> <p><i>Bestehend aus dicker TiCN und dicker Al₂O₃ Beschichtung. Gute Eigenschaften gegen plastische Verformung bei gleichzeitig hoher Härte und verbesserter Temperaturbeständigkeit. Bevorzugte Sorte für die Bearbeitung von nichtrostendem Stahl, Schlicht- bis Schruppbearbeitung. Schnittgeschwindigkeit kann um mehr als 25 % erhöht werden gegenüber der ersten Generation, während die Standzeit bei gleicher Schnittgeschwindigkeit um 30 % verlängert werden kann.</i></p>
<p>YBG205 M20 – M40 S05 – S30</p>	<p>Superfine TiAlN nano coating. Wear-resistant and heat-resistant grade. High hardness and excellent heat-resistance, providing effective protection for the cutting edge. Special coating technology ensures stronger combination of coating and substrate. Suitable for finishing of stainless steel.</p> <p><i>Superfeine TiAlN-Nanobeschichtung. Verschleißfeste und hitzebeständige Sorte mit hoher Härte, die einen wirksamen Schutz für die Schneide bietet. Spezielle Beschichtungstechnologie sorgt für eine verbesserte Kombination von Beschichtung und Substrat. Eignet sich für die Schlichtbearbeitung von nichtrostendem Stahl.</i></p>
<p>YB9320 P10 – 30 M10 – 30 S05 – 20</p>	<p>Nano multilayer coating with high toughness TiAlN substrate. Increased adhesion between coating and substrate and an excellent combination of toughness and hardness. The new grade also has a high temperature resistance. Suitable for a wide application range in stainless steel and also heat-resistant material.</p> <p><i>Neue TiAlN Beschichtungstechnologie mit optimaler Schichthftung und einer guten Kombination aus Zähigkeit und Härte. Die neue Sorte hat auch eine hohe Temperaturbeständigkeit. Für ein breites Anwendungsspektrum in nichtrostendem Stahl und schwerzerspanbaren Werkstoffen.</i></p>
<p>YNG151C P01 – 20 M01 – 20 K01 – 20</p>	<p>TiCN based cermet, through special pre-treatment, plus PVD nano TiAlN coating. Optimal combination of high wear resistance and good edge toughness, suitable for super-finishing and finishing of steel, stainless steel and cast iron for high surface finishing.</p> <p><i>TiCN + PVD Nano-TiAlN Beschichtung: Optimale Kombination von sehr hoher Verschleißfestigkeit und Schneidkanten-zähigkeit. Zum Feinschlichten und Schlichten von Stahl, nichtrostendem Stahl und Gusseisen mit hohen Oberflächengüten. TiCN + PVD Nano-TiAlN Beschichtung: Optimale Kombination von sehr hoher Verschleißfestigkeit und Schneidkanten-zähigkeit. Zum Feinschlichten und Schlichten von Stahl, nichtrostendem Stahl und Gusseisen mit hohen Oberflächengüten.</i></p>
<p>YBD152C K05 – K25</p>	<p>Improved grade with thicker Al₂O₃ coating in combination with the TC chip breaker for more stable performance, higher tool life and wear resistance under higher cutting condition up to Vc = 450 m/min.</p> <p><i>Verbesserte Sorte mit dickerer Al₂O₃ Beschichtung in Kombination mit dem TC-Spanbrecher. Für höhere Schnittleistung, mehr Standzeit und Verschleißfestigkeit bei hohen Schnittgeschwindigkeiten bis Vc = 450 m/min.</i></p>
<p>YD101 N5 – N30 S5 – S15</p>	<p>Uncoated cemented carbide of tungsten with fine grain and cobalt binder phase.</p> <p><i>Unbeschichtetes Hartmetall aus Wolframcarbid mit feiner Körnung und einer Bindefase aus Cobalt. K15 – K35</i></p>



Scan for PDF

Independent fine boring systems
Unabhängige Feinbohrsysteme



Sales center in Europe
Vertriebszentrale in Europa

ZCC Cutting Tools Europe GmbH

www.zccct-europe.com

Wanheimer Str. 57, 40472 Düsseldorf, Germany

Tel.: +49 (0) 211-989240-0

Fax: +49 (0) 211-989240-111

E-Mail: info@zccct-europe.com

Sales center in France
Vertriebszentrale in Frankreich

ZCC Cutting Tools Europe GmbH Succursale Française

www.zccct-europe.com

14, Allée Charles Pathé, 18000 Bourges, France

Tel.: +33 (0)2-454101-40

Fax: +33 (0)2-486619-46

E-Mail: ventes@zccct-europe.com

© Copyright by ZCC Cutting Tools Europe GmbH
All rights reserved / Alle Rechte vorbehalten.

All rights reserved. All descriptions and pictures are protected by copyright. Usage, modification and reproduction, completely or partially, without written permission are prohibited. Subject to technical changes and changes of the delivery program. Mistakes and printing errors are reserved.

Alle Rechte vorbehalten. Alle Beschreibungen und Abbildungen sind urheberrechtlich geschützt. Die Verwendung, Modifikation und Vervielfältigung, ganz oder teilweise, ohne schriftliche Genehmigung sind untersagt. Technische Änderungen und Änderungen des Lieferprogrammes vorbehalten. Für Druckfehler und Irrtümer keine Gewähr.