

serinex
CNC TOOLHOLDER SYSTEM 

ACCESSORI
ACCESSORIES
ACCESSOIRES
ZUBEHÖR

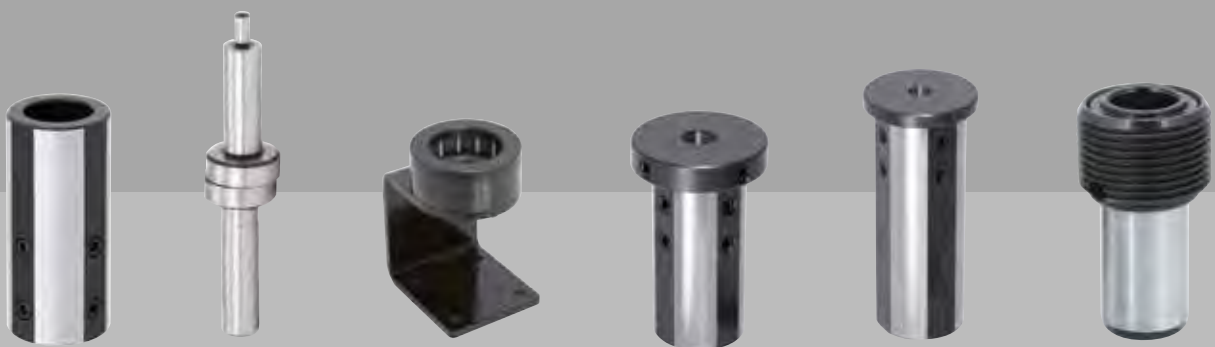

WWW.SERINEX.IT

ACCESSORI ACCESSORIES



ACCESSORI - INTRODUZIONE

In completamento alla produzione di pinze, ghiera, mandrini e codoli, SERINEX produce una serie di accessori:

- SMONTACONI
- BUSSOLE DI RIDUZIONE (boccole di riduzione)
- TASTATORE MECCANICO
- RACCORDI HSK e CHIAVI PER RACCORDI
- ANELLI e TASSELLI DI TRASCINAMENTO
- CHIAVI PER GHIERE
- CHIAVI A SETTORE
- CHIAVI DINAMOMETRICHE
- RIDUZIONI A CONO MORSE

Tutti garantiti dallo standard di qualità Serinex.

Questi particolari sono interamente eseguiti nella nostra moderna unità produttiva di Oggiono, situato a breve distanza da Lecco, in un comparto di oltre 7000 mq. dotato di un ampio parco macchine di ultima generazione

ACCESSORIES - INTRODUCTION



To complete the production of collets, nuts, toolholders and pull studs, SERINEX produces a series of accessories:

- INDEXABLE ASSEMBLY UNIVERSAL SUPPORT AND CLAMPING DEVICE ROLLING BEARING
- TOOLHOLDERS BUSHING
- FLOATING PRECISION CENTERING DEVICE
- HSK- COOLING TUBE AND HSK-COOLING TUBE WRENCHES
- RINGS AND DRIVING KEY
- WRENCHES FOR NUTS
- HOOK SPANNER WRENCHES
- DYNAMOMETRIC WRENCHES
- MORSE TAPER SLEEVES

All guaranteed by Serinex quality standard

These items are entirely performed in our modern division in Oggiono, not far from Lecco, in a place of more than 7000 mq. , supplied with a wide rolling stock with a high daily production.

ATTENZIONE / ATTENTION

DATI TECNICI ED IMMAGINI SONO INDICATIVI. SERINEX SI RISERVA DI APPORTARE AGGIORNAMENTI IN QUALSIASI MOMENTO E SENZA OBBLIGO DI PREAVVISO.

TECHNICAL DATA AND DRAWINGS ARE FOR INFORMATION PURPOSES ONLY. SERINEX RESERVES THE RIGHT TO UPDATE SPECS AT ANYTIME AND WITHOUT NOTICE.

ACCESSOIRES ZUBEHÖR

ACCESSOIRES - INTRODUCTION



En complément à la production des pinces, d'écrous, des mandrins et des tirettes, nous produisons une série d'accessoires:

- DEMONTE-CONES
- DOUILLES DE REDUCTIONS
- PINNULES MECANIQUES
- RACCORDES DE ARROSAGE - HSK
- CLÉS POUR ÉCROUS
- CLÉS À CROCHET
- CLÉS DINAMOMETRIQUES
- RÉDUCTIONS À CÔNE MORSE

tous garantis par le standard de qualité Serinex.

Tous ces articles sont entièrement produits au sein de notre unité moderne de production d'Annone Brianza, sise à proximité de Lecco, dans un

compartiment de plus de 7000 m², doté d'un large parc de machines avec une production journalière élevée.

ZUBEHÖR - EINFÜHRUNG



Neben unserer Produktion von Spannzangen, Muttern, Spannfütern und Anzugsbolzen, stellen wir eine Vielfalt von zusätzlichem Zubehör her, die von dem Serinex Qualitätsstandard garantiert werden:

- MONTAGEUNTERSTÜTZUNGEN
- REDUZIERHÜLSEN - REDUZIERUNGEN
- MECHANISCHE MESSTASTER
- HSK ANSCHLÜSSE UND ANSCHLUSS – SCHLÜSSEL
- MITNEHMERRINGE UND –DÜBEL
- MUTTERNSCHLÜSSEL
- HAKENSCHLÜSSEL
- ZWISCHENHULSEN

Diese Zubehörsind alle völlig bei unserem modernen Produktionsbetrieb in Oggiono hergestellt, der sich in einer Zubehöre Abteilung von mehr als 7000 Quadratmetern in der Umgebung von Lecco befindet und über einen breiten Maschinenpark mit einer hohen täglichen Produktion ausgestattet ist

AVERTISSEMENT / WARNUNG

DONNÉES TECHNIQUES ET PHOTOS SONT À TITRE INDICATIF. SERINEX SE RÉSERVE LE DROIT DE METTRE À JOUR À TOUT MOMENT ET SANS PRÉAVIS.

TECHNISCHE DATEN UND BILDER SIND RICHTWERTE. SERINEX BEHÄLT SICH DAS RECHT VOR, JEDERZEIT UND OHNE VORHERIGE ANKÜNDIGUNG ZU AKTUALISIEREN.



SUPPORTO DI MONTAGGIO

ORIENTABILE UNIVERSALE - A RULLI - PER CILINDRICI

UNIVERSAL ASSEMBLY DEVICE - WITH ROLLING BEARING - FOR CYLINDRICAL TOOL

SUPPORT DE MONTAGE UNIVERSAL - A ROULEAUX - POUR CYLINDRICAL MANDRIN

MONTAGE-AUFLAGE UNIVERSAL - AUF ROLLEN - FÜR ZYLINDRISCHE SPANNFUTTER

433



BUSSOLE DI RIDUZIONE

CON BATTUTA - SENZA BATTUTA

TOOLHOLDER BUSHINGS

DOUILLE AVEC COLLERETTE - DOUILLE SANS COLLERETTE

REDUZIERHÜLSEN MIT ANSCHLAG - OHNE ANSCHLAG

440



TASTATORE MECCANICO

TASTATORE MECCANICO UNIVERSALE - MOLLE DI RICAMBIO

FLOATING PRECISION CENTERING DEVICE - REPLACEMENT SPRINGS

PINNULE DE CENTRAGE UNIVERSEL

MECHANISCHER TASTER - ERSATZFEDERN

445



RACCORDI PER HSK

RACCORDI PER REFRIGERANTE HSK - CHIAVE PER RACCORDI

HSK COOLING TUBE - HSK-COOLING TUBE WRENCHES

RACCORDS POUR HSK - CLE POUR RACCORDS

ANSCHLÜSSE FÜR KÜHLMITTEL HSK - ANSCHLUSS SCHLÜSSEL

447



CHIAVI

CHIAVI PER GHIERA DIN6499 - CHIAVI A SETTORE - CHIAVI DINAMOMETRICHE

WRENCHES FOR NUTS DIN6499 - DYNAMOMETRIC WRENCHES

CLE POUR ECROU DIN6499 - CLE DINAMOMETRIQUES

SCHLÜSSEL FÜR SPANNMUTTERN - SEGMENTSCHLÜSSEL - DYNAMOMETRISCHE

449



RIDUZIONI A CONO MORSE

RIDUZIONE A CONO MORSE - BUSSOLE DI RIDUZIONE A CONO MORSE

MORSE TAPER ADAPTERS - MORSE TAPER SLEEVES

RÉDUCTIONS À CÔNE MORSE - DOUILLE DE RÉDUCTIONS À CÔNE MORSE

KONISCHE REDUZIERUNG DES SCHRAUBSTOCKES

455

SUPPORTO DI MONTAGGIO

TOOL ASSEMBLY DEVICE

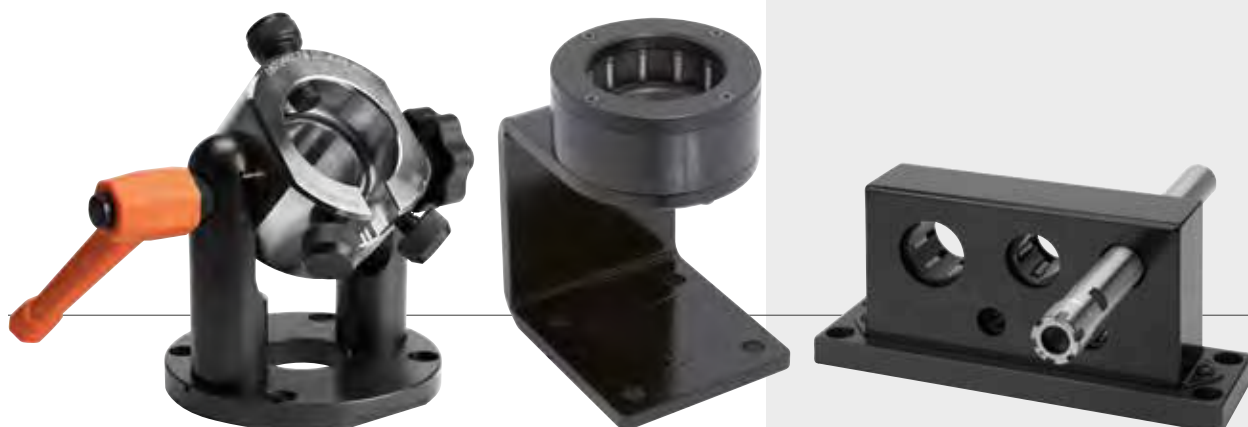

SUPPORTO DI MONTAGGIO ORIENTABILE UNIVERSALE

*INDEXABLE ASSEMBLY
UNIVERSAL SUPPORT*



SUPPORTO DI MONTAGGIO A RULLI

*CLAMPING DEVICE WITH ROLLING
BEARING*



SUPPORTO DI MONTAGGIO PER MANDRINI CILINDRICI

*INDEXABLE SUPPORT FOR A
CYLINDRICAL TOOL HOLDERS*

CARATTERISTICHE DEI SUPPORTI DI MONTAGGIO

FEATURES OF INDEXABLE SUPPORT

CARACTERISTIQUES TECHNIQUES DES DEMONTE CONE

MERKMALE DER MONTAGEHALTERUNGEN



SUPPORTO DI MONTAGGIO ORIENTABILE UNIVERSALE

Consentono l'orientamento dei portautensili sugli assi verticali ed orizzontali per facilitare il montaggio degli utensili. Il cono dei portautensili è protetto da due anelli O-ring in NBR opportunamente posizionati.

Corpo in acciaio, leve di manovra in materiale termoplastico.

Sono fissati con 4 viti al banco di lavoro.

I supporti di montaggio devono essere fissati al banco di lavoro o al carrello portautensili.

La testa portautensile è orientabile in verticale e orizzontale.

1. vite d'arresto per mandrini HSK63A / HSK100A / BT40 / BT50 / SK40 / SK50 DIN69871 / ISO40 DIN2080
2. vite di sicurezza per la flangia BT40 / BT50 / SK40 / ISO50 DIN 2080
3. vite di sicurezza per la flangia SK40 / SK50 DIN 69871



SUPPORT DE MONTAGE ORIENTABLE UNIVERSEL

Ils permettent l'orientation des porte-outils sur les axes verticales et horizontales pour faciliter le montage des outils.

Le cône des porte-outils est protégé par deux joints toriques en NBR convenablement positionnés. Le corps en Acier, les leviers de manœuvre en matériel thermoplastique. Il sont

fixés par 4 vis à la table de montage Les supports de montage

doivent être fixés à la table de montage ou au chariot porte-outil.

La tête du porte-outil est orientable en verticale et horizontale.

1. Vis d'arrêt pour les mandrins HSK63A / HSK100A / BT40 / BT50 / SK40 DIN69871 / SK50 DIN69871 / ISO40 DIN2080
2. Vis de sécurité pour la flange BT40 / BT50 / SK40 DIN69871 / ISO50 DIN 2080
3. Vis de sécurité pour la flange SK40 DIN69871 / SK50 DIN 69871



INDEXABLE ASSEMBLY UNIVERSAL SUPPORT

Head fixture can be set in two position, vertical and horizontal, for easy access to the cutting tool. The tapers protection is granted by two special NBR O-ring.

Body in steel, operating levers in thermoplastic material.

Can be mounted on work table with four screws.

The mounting fixtures must be fixed to a bench or to a tool cart.

Head fixture can be set in vertical and horizontal position.

1. set screw for tools-shank HSK63A / HSK100A / BT40 / BT50 / SK40 / SK50 DIN69871 / ISO40 DIN2080
2. safety screw for "V" flange BT40 / BT50 / SK40 / ISO50 DIN2080
3. safety screw for "V" flange SK40 / SK50 DIN 69871



UNIVERSAL SCHWANKENDE MONTAGEHALTER

Diese ermöglichen die Schwankung der Werkzeughalter auf den senkrechten und waagrechten Achsen und erleichtern die Montage der Werkzeuge.

Der Konus der Werkzeughalter ist mit zwei O-Ringe aus NBR geschützt.

Stahlkörper, Schaltunghebel aus thermoplastik, und sind mit

4 Schrauben an der Werkbank befestigt. Die Montagehalter müssen an der Werkbank oder am Werkzeugwagen befestigt werden.

Der Kopf des Werkzeughalters ist schwenkbar senkrecht und waagrecht.

1. Klemmschraube für Spannfutter HSK63A / 100A / BT40 / BT50 / SK40 / SK50 DIN69871 / ISO40 DIN2080
2. Sicherheitsschraube für die Flansche BT40 / BT50 / ISO 40 DIN 2080 / ISO50 DIN 2080
3. Sicherheitsschraube für die Flansche SK40 / SK50 DIN 69871





MECCANICO UNIVERSALE - INDEXABLE ASSEMBLY UNIVERSAL

Cod.	TYPE	D	BASE	H	ADATTO PER / SUITABLE FOR
PV00141	SMONTACONO 30 meccanico universale <i>Indexable Assembly Univ. support 30</i>	50	150	160	SK30 DIN69871 - ISO 30 DIN2080 - BT30 - CAT30 - HSK50A - CAPTO C5
PV00069	SMONTACONO 40 meccanico universale <i>Indexable Assembly Univ. support 40</i>	63	150	160	SK40 DIN69871 - ISO 40 DIN2080 - BT40 - CAT40 - HSK63A - CAPTO C6
PV00080	SMONTACONO 50 meccanico universale <i>Indexable Assembly Univ. support 50</i>	100	200	210	SK50 DIN69871 - ISO 50 DIN2080 - BT50 - CAT50 - HSK100A - CAPTO C10



CARATTERISTICHE DEI SUPPORTI DI MONTAGGIO

FEATURES OF INDEXABLE SUPPORT

CARACTERISTIQUES TECHNIQUES DES DEMONTE CONE

MERKMALE DER MONTAGEHALTERUNGEN



SUPPORTO DI MONTAGGIO A RULLI

Una speciale gabbia a rullini bidirezionale blocca il portautensile sulla flangia per consentire il montaggio e lo smontaggio degli utensili e degli accessori sul corpo mandrino. È garantita la massima protezione (per mancanza di contatto) del cono mandrino.



SUPPORT DE MONTAGE A ROULEAUX

Une cage spéciale à rouleaux bidirectionnelle bloque le porte-outil sur la flange pour permettre le montage et le démontage des outils et des accessoires sur le bloc mandrin. Il est garanti la protection maximale (pour éviter le contact) du cône mandrin.



CLAMPING DEVICE WITH ROLLING BEARING

A special bidirectional roller bearing locks the toolholder on the flange to allow the assembly and the disassembly of tools and accessories from the toolholder. It's guarantee the maximum protection of the toolholder cone (because the contact surface of the toolholder is only the flange)



MONTAGEHALTER AUF ROLLEN

Ein spezieller Rollenkäfig, zweiseitig gerichtet, blockiert den Werkzeughalter auf die Flansche. Er ermöglicht die Montage und die Abmontage der Werkzeuge und der Zubehöre auf dem Spannfutterkörper. Da kein kontakt besteht, hat man einen max. Schutz des Spannfutterkonus.

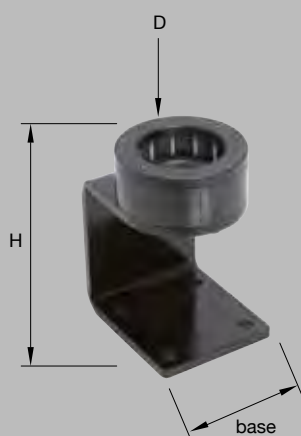



**BREVETTATO
PATENT**

MONTAGGIO A RULLI - CLAMPING DEVICE WITH ROLLING BEARING

Cod.	TYPE	D	BASE	H	ADATTO PER / SUITABLE FOR
PV00148	SMONTACONO A RULLI HSK25 <i>Clamping device with roller bearing HSK 25</i>	25	100	130	HSK25
PV00149	SMONTACONO A RULLI HSK32 <i>Clamping device with roller bearing HSK 32</i>	32	100	130	HSK32 - CAPTO C4
PV00071	SMONTACONO A RULLI HSK40 DIAM.40 <i>Clamping device with roller bearing HSK 40</i>	40	100	160	HSK40 - CAPTO C4
PV00106	SMONTACONO RULLI UNIV.90° SK30 FL. 46 <i>Clamping device with roller bearing ISO30 FL. 46</i>	46	100	160	BT30 MAS403 - TCL30 FL46
PV00103	SMONTACONO RULLI UNIV.90° SK30 FL 49 <i>Clamping device with roller bearing SK30 FLANGE 49</i>	49	100	160	TCL30 FL49
PV00083	SMONTACONO RULLI UNIV. 90 SK30 <i>Clamping device with roller bearing SK30 FL. 50</i>	50	100	160	ISO30 DIN2080 - SK30 DIN 69871 - HSK50 CAPTO C5
PV00107	SMONTACONO RULLI UNIV. 90° BT35 FL. 53 <i>Clamping device with roller bearing BT35 FL. 53</i>	53	100	160	DIN 69871 FL. 53
PV00099	SMONTACONO RULLI UNIV.90° SK30 Clamping device with roller bearing SK30 FL.58	58	100	160	TCL30 FL58
PV00077	SMONTACONO RULLI UNIV. 90 SK40 <i>Clamping device with roller bearing SK40 FL. 63</i>	63	100	160	BT40 - HSK63 - ISO40 DIN 2080 - SK40 DIN 69871 CAPTO C6
PV00150	SMONTACONO A RULLI HSK80 <i>Clamping device with roller bearing HSK 80</i>	80	150	240	HSK40 - CAPTO C8
PV00108	SMONTACONO RULLI UNIV. 90° HSK63WE FL. 85 <i>Clamping device with roller bearing HSK63WE FL. 85</i>	85	150	230	HSK85
PV00078	SMONTACONO RULLI UNIV. 90° SK50 <i>Clamping device with roller bearing SK50 FL. 100</i>	100	150	220	BT50 - ISO50 DIN2080 - SK50 DIN 69871 - HSK100 - CAPTO C10

CARATTERISTICHE DEI SUPPORTI DI MONTAGGIO

FEATURES OF INDEXABLE SUPPPORT

CARACTERISTIQUES TECHNIQUES DES DEMONTE CONE

MERKMALE DER MONTAGEHALTERUNGEN

SUPPORTO MONTAGGIO PER MANDRINI CILINDRICI

- Permettono il montaggio e lo smontaggio dei mandrini cilindrici di diversi diametri e lunghezze.
- Può essere fissato al banco di lavoro grazie a quattro fori sulla base orizzontale.
- Per una corretta introduzione del mandrino cilindrico, si consiglia una piccola rotazione: oraria o antioraria.

DEMONTE POUR CYLINDRICAL MANDRIN

- Ces demonte-cones permettent l'assemblage et le démontage des mandrins cylindriques, de différents diamètres et longueurs.
- Cet article peut être fixé au banc de travail grâce à quatre trous sur la base horizontale.
- Pour une correcte introduction du mandrin cylindrique, il est conseillé une petite rotation: horaire ou anti-horaire.

INDEXABLE SUPPORT FOR A CYLINDRICAL TOOL HOLDERS

- These items allow the assembly and disassembly of cylindrical tool holders, of different diameters and lengths.
It can be fixed to the workbench with four holes on the horizontal base
- For a proper introduction of the tool holder, we recommended a small rotation: clockwise or counterclockwise

MONTAGEHALTER FUER ZYLINDRISCHE SPANNFUTTER

- Diese montagehalter ermöglichen die Montage und Demontage des zylindrischen spannfutter.
- Diese Montagehalterung kann an der Werkbank durch die vier Löcher im Boden befestigt werden.
- Fuer eine korrekte einfuehrung des zylindrische spannfutter, ist es ratsam eine kleine links-und rechtsdrehung zu machen.





PER MANDRINI CILINDRICI - FOR CYLINDRICAL COLLET CHUCKS

Cod.	TYPE	ADATTO PER / SUITABLE FOR
PV00145	SMONTACONO PER CILINDRICI DIAM. 12-16-20 <i>Indexable support for a cylindrical tool holders diam. 12-16-20</i>	MANDRINI CILINDRICI DIAMETRO ESTERNO 12-16-20 <i>Cylindrical tool holders from the outer diameter 12-16-20</i>
PV00146	SMONTACONO PER CILINDRICI DIAM. 20-25-32 <i>Indexable support for a cylindrical tool holders diam. 20-25-32</i>	MANDRINI CILINDRICI DIAMETRO ESTERNO 20-25-32 <i>Cylindrical tool holders from the outer diameter 20-25-32</i>
PV00147	SMONTACONO PER CILINDRICI DIAM. 12-16-20-25-32 <i>Indexable support for a cylindrical tool holders diam. 12-16-20-25-32</i>	MANDRINI CILINDRICI DIAMETRO ESTERNO 12-16-20-25-32 <i>Cylindrical tool holders from the outer diameter 12-16-20-25-32</i>

BUSSOLE DI RIDUZIONE

TOOLHOLDER BUSHING



CON BATTUTA

HEADED REDUCTION SLEEVES



SENZA BATTUTA

UNIVERSAL REDUCTION SLEEVES



MAZAK

MAZAK TYPE



CON BATTUTA - HEADED REDUCTION SLEEVES - DIAM. 20 L55

Cod.	TYPE	ØD	L	ØD1	L1	Cod.	TYPE	ØD	L	ØD1	L1
TB.20-6.55	BUSSOLA RIDUZIONE STD 20 D.6	20	55	6	5	TB.20-12.55	BUSSOLA RIDUZIONE STD 20 D.12	20	55	12	5
TB.20-8.55	BUSSOLA RIDUZIONE STD 20 D.8	20	55	8	5	TB.20-16.55	BUSSOLA RIDUZIONE STD 20 D.16	20	55	16	5
TB.20-10.55	BUSSOLA RIDUZIONE STD 20 D.10	20	55	10	5						



CON BATTUTA - HEADED REDUCTION SLEEVES - DIAM. 25 L65

Cod.	TYPE	ØD	L	ØD1	L1	Cod.	TYPE	ØD	L	ØD1	L1
TB.25-6.65	BUSSOLA RIDUZIONE STD 25 D.6	25	65	6	5	TB.25-12.65	BUSSOLA RIDUZIONE STD 25 D.12	25	65	12	5
TB.25-8.65	BUSSOLA RIDUZIONE STD 25 D.8	25	65	8	5	TB.25-16.65	BUSSOLA RIDUZIONE STD 25 D.16	25	65	16	5
TB.25-10.65	BUSSOLA RIDUZIONE STD 25 D.10	25	65	10	5	TB.25-20.65	BUSSOLA RIDUZIONE STD 25 D.20	25	65	20	5



CON BATTUTA - HEADED REDUCTION SLEEVES - DIAM. 32 L70

Cod.	TYPE	ØD	L	ØD1	L1	Cod.	TYPE	ØD	L	ØD1	L1
TB.32-6.70	BUSSOLA DI RIDUZIONE D.32-6	32	70	6	5	TB.32-16.70	BUSSOLA DI RIDUZIONE D.32-16	32	70	16	5
TB.32-8.70	BUSSOLA DI RIDUZIONE D.32-8	32	70	8	5	TB.32-20.70	BUSSOLA DI RIDUZIONE D.32-20	32	70	20	5
TB.32-10.70	BUSSOLA DI RIDUZIONE D.32-10	32	70	10	5	TB.32-25.70	BUSSOLA DI RIDUZIONE D.32-25	32	70	25	5
TB.32-12.70	BUSSOLA DI RIDUZIONE D.32-12	32	70	12	5						

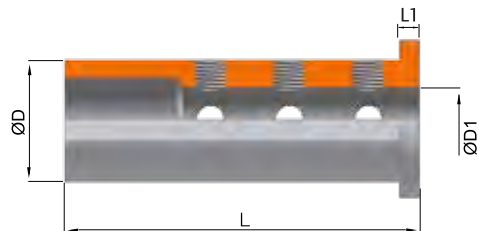
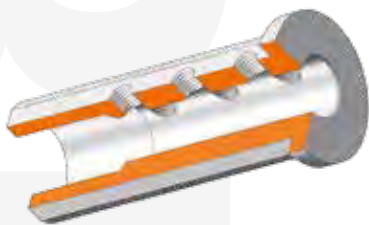

CON BATTUTA - HEADED REDUCTION SLEEVES - DIAM. 32 L90

Cod.	TYPE	ØD	L	ØD1	L1
TB.32-6.90	BUSSOLA RIDUZIONE STD 32 D.6	32	90	6	5
TB.32-8.90	BUSSOLA RIDUZIONE STD 32 D.8	32	90	8	5
TB.32-10.90	BUSSOLA RIDUZIONE STD 32 D.10	32	90	10	5
TB.32-12.90	BUSSOLA RIDUZIONE STD 32 D.12	32	90	12	5

Cod.	TYPE	ØD	L	ØD1	L1
TB.32-16.90	BUSSOLA RIDUZIONE STD 32 D.16	32	90	16	5
TB.32-20.90	BUSSOLA RIDUZIONE STD 32 D.20	32	90	20	5
TB.32-25.90	BUSSOLA RIDUZIONE STD 32 D.25	32	90	25	5

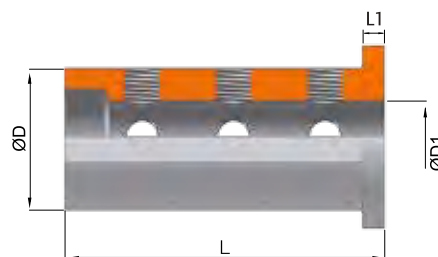
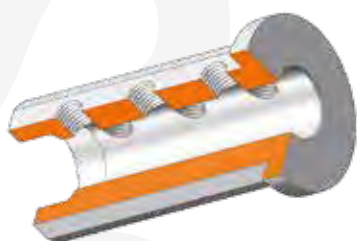

CON BATTUTA - HEADED REDUCTION SLEEVES - DIAM. 40 L80

Cod.	TYPE	ØD	L	ØD1	L1
TB.40-8.80	BUSSOLA DI RIDUZIONE D.40-8	40	80	8	5
TB.40-10.80	BUSSOLA DI RIDUZIONE D.40-10	40	80	10	5
TB.40-12.80	BUSSOLA DI RIDUZIONE D.40-12	40	80	12	5
TB.40-16.80	BUSSOLA DI RIDUZIONE D.40-16	40	80	16	5

Cod.	TYPE	ØD	L	ØD1	L1
TB.40-20.80	BUSSOLA DI RIDUZIONE D.40-20	40	80	20	5
TB.40-25.80	BUSSOLA DI RIDUZIONE D.40-25	40	80	25	5
TB.40-32.80	BUSSOLA DI RIDUZIONE D.40-32	40	89	32	5

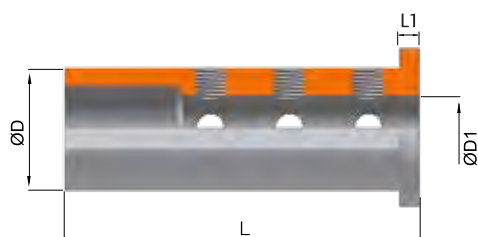
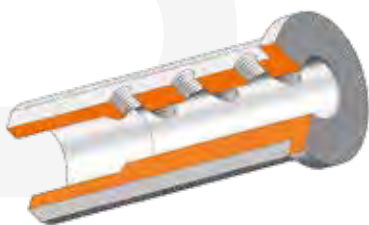

CON BATTUTA - HEADED REDUCTION SLEEVES - DIAM. 40 L110

Cod.	TYPE	ØD	L	ØD1	L1
TB.40-8.110	BUSSOLA RIDUZIONE STD 40 D. 8	40	110	8	5
TB.40-10.110	BUSSOLA RIDUZIONE STD 40 D.10	40	110	10	5
TB.40-12.110	BUSSOLA RIDUZIONE STD 40 D.12	40	110	12	5
TB.40-16.110	BUSSOLA RIDUZIONE STD 40 D.16	40	110	16	5

Cod.	TYPE	ØD	L	ØD1	L1
TB.40-20.110	BUSSOLA RIDUZIONE STD 40 D.20	40	110	20	5
TB.40-25.110	BUSSOLA RIDUZIONE STD 40 D.25	40	110	25	5
TB.40-32.110	BUSSOLA RIDUZIONE STD 40 D.32	40	110	32	5



CON BATTUTA - HEADED REDUCTION SLEEVES - DIAM. 50 L90

Cod.	TYPE	ØD	L	ØD1	L1	Cod.	TYPE	ØD	L	ØD1	L1
TB.50-16.90	BUSSOLA DI RIDUZIONE D.50-16	50	90	16	5	TB.50-32.90	BUSSOLA DI RIDUZIONE D.50-32	50	90	32	5
TB.50-20.90	BUSSOLA DI RIDUZIONE D.50-20	50	90	20	5	TB.50-40.90	BUSSOLA DI RIDUZIONE D.50-40	50	90	40	5
TB.50-25.90	BUSSOLA DI RIDUZIONE D.50-25	50	90	25	5						



CON BATTUTA - HEADED REDUCTION SLEEVES - DIAM. 50 L130

Cod.	TYPE	ØD	L	ØD1	L1	Cod.	TYPE	ØD	L	ØD1	L1
TB.50-16.130	BUSSOLA RIDUZIONE STD 50 D.16	50	130	16	5	TB.50-32.130	BUSSOLA RIDUZIONE STD 50 D.32	50	130	32	5
TB.50-20.130	BUSSOLA RIDUZIONE STD 50 D.20	50	130	20	5	TB.50-40.130	BUSSOLA RIDUZIONE STD 50 D.40	50	130	40	5
TB.50-25.130	BUSSOLA RIDUZIONE STD 50 D.25	50	130	25	5						



SENZA BATTUTA - UNIVERSAL REDUCTION SLEEVES - DIAM. 32 L70

Cod.	TYPE	ØD	L	ØD1	Cod.	TYPE	ØD	L	ØD1
TB.32-8.70.SB	BUSSOLA DI RID. E2-1 D32X8	32	70	8	TB.32-16.70.SB	BUSSOLA DI RID. E2-1 D32X16	32	70	16
TB.32-10.70.SB	BUSSOLA DI RID. E2-1 D32X10	32	70	10	TB.32-20.70.SB	BUSSOLA DI RID. E2-1 D32X20	32	70	20
TB.32-12.70.SB	BUSSOLA DI RID. E2-1 D32X12	32	70	12					



SENZA BATTUTA - UNIVERSAL REDUCTION SLEEVES - DIAM. 40 L80

Cod.	TYPE	ØD	L	ØD1	Cod.	TYPE	ØD	L	ØD1
TB.40-8.80.SB	BUSSOLA DI RID. E2-1 D40X8	40	80	8	TB.40-16.80.SB	BUSSOLA DI RID. E2-1 D40X16	40	80	16
TB.40-10.80.SB	BUSSOLA DI RID. E2-1 D40X10	40	80	10	TB.40-20.80.SB	BUSSOLA DI RID. E2-1 D40X20	40	80	20
TB.40-12.80.SB	BUSSOLA DI RID. E2-1 D40X12	40	80	12	TB.40-25.80.SB	BUSSOLA DI RID. E2-1 D40X25	40	80	25

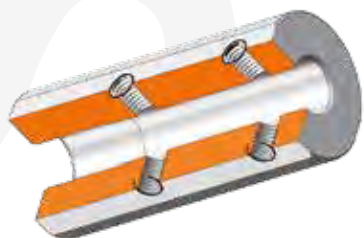

SENZA BATTUTA - UNIVERSAL REDUCTION SLEEVES - DIAM. 60 L160

Cod.	TYPE	ØD	L	ØD1	Cod.	TYPE	ØD	L	ØD1
TB.60-16.160.SB	BUSSOLA DI RID. E2-1 D60X16	60	160	16	TB.60-32.160.SB	BUSSOLA DI RID. E2-1 D60X32	60	160	32
TB.60-20.160.SB	BUSSOLA DI RID. E2-1 D60X20	60	160	20	TB.60-40.160.SB	BUSSOLA DI RID. E2-1 D60X40	60	160	40
TB.60-25.160.SB	BUSSOLA DI RID. E2-1 D60X25	60	160	25					

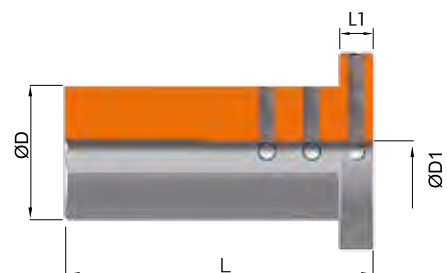
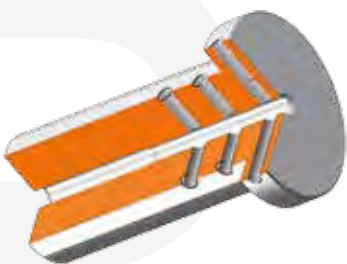

TIPO MAZAK - MAZAK TYPE HEADED REDUCTION SLEEVES - DIAM. 40 L80

Cod.	TYPE	ØD	L	ØD1	L1	Cod.	TYPE	ØD	L	ØD1	L1
TB.40-6.80.MAZAK	BUSSOLA TIPO MAZAK D.40-6	40	80	6	5	TB.40-16.80.MAZAK	BUSSOLA TIPO MAZAK D.40-16	40	80	16	5
TB.40-8.80.MAZAK	BUSSOLA TIPO MAZAK D.40-8	40	80	8	5	TB.40-18.80.MAZAK	BUSSOLA TIPO MAZAK D.40-18	40	80	18	5
TB.40-10.80.MAZAK	BUSSOLA TIPO MAZAK D.40-10	40	80	10	5	TB.40-20.80.MAZAK	BUSSOLA TIPO MAZAK D.40-20	40	80	20	5
TB.40-12.80.MAZAK	BUSSOLA TIPO MAZAK D.40-12	40	80	12	5	TB.40-25.80.MAZAK	BUSSOLA TIPO MAZAK D.40-25	40	80	25	5
TB.40-14.80.MAZAK	BUSSOLA TIPO MAZAK D.40-14	40	80	14	5	TB.40-32.80.MAZAK	BUSSOLA TIPO MAZAK D.40-32	40	80	32	5

TASTATORE MECCANICO

FLOATING PRECISION CENTERING DEVICE



TASTATORE
*FLOATING PRECISION CENTERING
DEVICE*



MOLLE DI RICAMBIO
REPLACEMENT SPRINGS

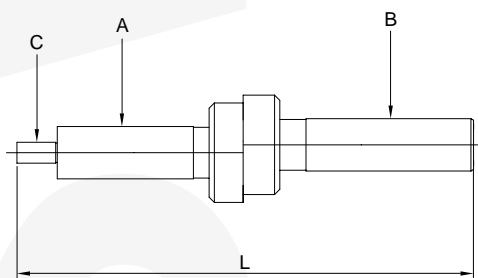

TASTATORE MECCANICO FLOTTANTE - *FLOATING PRECISION CENTERING DEVICE*

Cod.	TYPE	A	B	L	C
TAS020	TASTATORE MECCANICO UNIVERSALE	10	10	87,2	4

MOLLE DI RICAMBIO - *REPLACEMENT SPRINGS*

Cod.	TYPE
TAS005	MOLLA DIAM.0,6 PER TASTATORE MECCANICO

RACCORDI PER HSK

HSK COOLING TUBE



RACCORDO

HSK COOLING TUBE

CHIAVE PER RACCORDO

HSK-COOLING TUBE WRENCHES

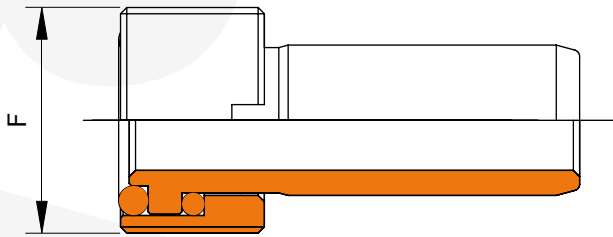

RACCORDI PER REFRIGERANTE HSK - HSK COOLING TUBE

Cod.	TYPE	ØD1	Cod.	TYPE	ØD1
RACHSK6	RACCORDO HSK32/M10	M10x1	RACHSK3	RACCORDO HSK63/M18	M18x1
RACHSK1	RACCORDO HSK40/M12	M12x1	RACHSK4	RACCORDO HSK80/M20	M20x1,5
RACHSK2	RACCORDO HSK50/M16	M16x1	RACHSK5	RACCORDO HSK100/M24	M24x1,5



CHIAVI PER RACCORDI - HSK-COOLING TUBE WRENCHES

Cod.	TYPE	M	Cod.	TYPE	M
WR.HSK.40	CHIAVE PER RACCODO HSK40	12	WR.HSK.80	CHIAVE PER RACCODO HSK80	20
WR.HSK.50	CHIAVE PER RACCODO HSK50	16	WR.HSK.100	CHIAVE PER RACCODO HSK100	24
WR.HSK.63	CHIAVE PER RACCODO HSK63	18			

CHIAVI PER GHIERE

WRENCHES FOR NUTS



PER GHIERA ER DIN6499
FOR CLAMPING NUT DIN6499

PER GHIERA ESAGONALE
FOR HEXAGONAL NUT

A SETTORE
FOR CLAMPING NUT EOC DIN6388

DINAMOMETRICA
DYNAMOMETRIC



PER GHIERA ER DIN 6499 MINI - FOR MINI CLAMPING NUT DIN 6499

Cod.	TYPE	Cod.	TYPE
WR.8.M	ERX8M	WR.20.M	ERX20M
WR.11.M	ERX11M	WR.25.M	ERX25M
WR.16.M	ERX16M		



PER GHIERA ER DIN 6499 STANDARD - FOR STANDARD CLAMPING NUT DIN 6499

Cod.	TYPE	Cod.	TYPE
WR.16.ST	ERX16	WR.32.ST	ERX32
WR.20.ST	ERX20	WR.40.ST	ERX40
WR.25.ST	ERX25	WR.50.ST	ERX50

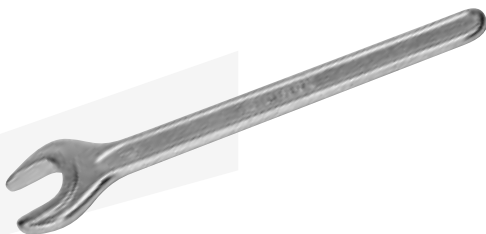

PER GHIERA ESAGONALE - FOR HEXAGONAL CLAMPING NUT

Cod.	TYPE	Cod.	TYPE
WR.11.EX	ER11EX	WR.20.EX	ER20EX
WR.16.EX	ER16EX	WR.25.EX	ER25EX

Fig. 1



Fig. 2



A SETTORE PER PINZA EOC DIN 6388 - FOR CLAMPING NUT EOC DIN 6388

Cod.	TYPE	FIGURA	Cod.	TYPE	FIGURA
WR.16.EOC	CHIAVE PER GHIERA EOC 16	1	WR.25.EOC	CHIAVE PER GHIERA EOC 25	2

NEW

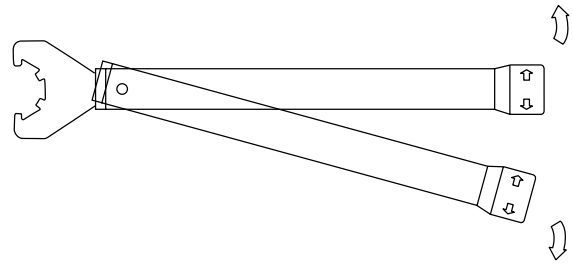

DINAMOMETRICHE STANDARD - STANDARD DYNAMOMETRIC

Cod.	TYPE	COPPIA SERRAGGIO
WR.DIN.16	CHIAVE DINAMOMETRICA PER ER16	23-35 45-55
WR.DIN.20	CHIAVE DINAMOMETRICA PER ER20	30-40 60-70
WR.DIN.25	CHIAVE DINAMOMETRICA PER ER25	45-55 80-90

Cod.	TYPE	COPPIA SERRAGGIO
WR.DIN.32	CHIAVE DINAMOMETRICA PER ER32	65-70 120-130
WR.DIN.40	CHIAVE DINAMOMETRICA PER ER40	110-120 190-200

NEW

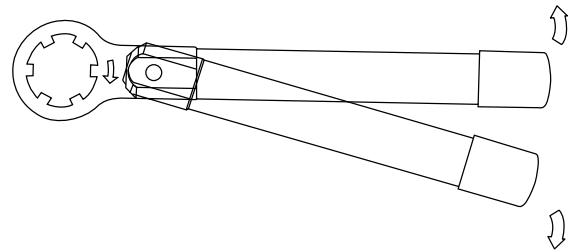
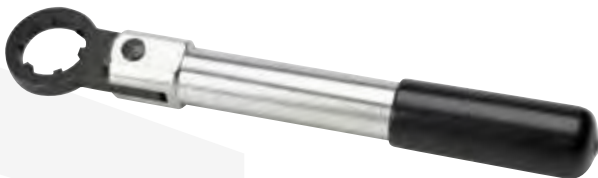

DINAMOMETRICHE MINI - MINI DYNAMOMETRIC

Cod.	TYPE
WR.DIN.8.MINI	CHIAVE DINAMOMETRICA PER ER8MINI
WR.DIN.11.MINI	CHIAVE DINAMOMETRICA PER ER11MINI
WR.DIN.16.MINI	CHIAVE DINAMOMETRICA PER ER16MINI

Cod.	TYPE
WR.DIN.20.MINI	CHIAVE DINAMOMETRICA PER ER20MINI
WR.DIN.25.MINI	CHIAVE DINAMOMETRICA PER ER25MINI

NEW



CHIAVI A RULLI STANDARD - ROLLER BEARING STANDARD WRENCH

Cod.	TYPE	H MIN	H MAX
WR.RUL.16	PER GHIERE ER16 CON E SENZA TACCHE	210	300
WR.RUL.20	PER GHIERE ER20 CON E SENZA TACCHE	210	300
WR.RUL.25	PER GHIERE ER25 CON E SENZA TACCHE	285	400
WR.RUL.32	PER GHIERE ER32 CON E SENZA TACCHE	285	413
WR.RUL.40	PER GHIERE ER40 CON E SENZA TACCHE	310	440

NEW

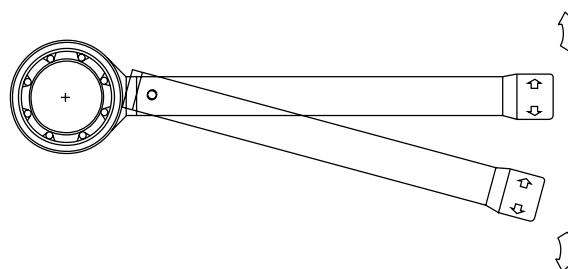

CHIAVI A RULLI DINAMOMETRICHE - ROLLER BEARING DYNAMOMETRIC WRENCH

Cod.	TYPE	Cod.	TYPE
WR.RUL.DIN.16	PER GHIERE ER16 CON E SENZA TACCHE	WR.RUL.DIN.32	PER GHIERE ER32 CON E SENZA TACCHE
WR.RUL.DIN.20	PER GHIERE ER20 CON E SENZA TACCHE	WR.RUL.DIN.40	PER GHIERE ER40 CON E SENZA TACCHE
WR.RUL.DIN.25	PER GHIERE ER25 CON E SENZA TACCHE		

NEW

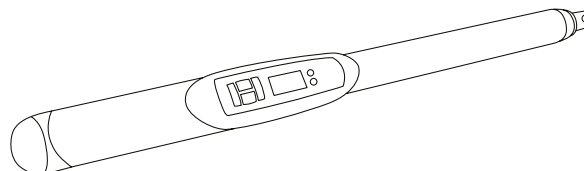

CHIAVE DIGITALE DINAMOMETRICA - DIGITAL DYNAMOMETRIC WRENCH

Cod.	TYPE	CAPACITÀ
WR.DIG	CHIAVE DIGITALE DINAMOMETRICA	20-200 NM

NEW



Fig.1



Fig.2



Fig.3



Fig.4

INSERTI PER CHIAVE DINAMOMETRICA - *INTERCHANGEABLE HEADS*

Cod.	TYPE	FIG.
INS.DIG.ER16M	PER GHIERA ER16 MINI	1
INS.DIG.ER20M	PER GHIERA ER20 MINI	1
INS.DIG.ER25M	PER GHIERA ER25 MINI	1
INS.DIG.ER16.EX	PER GHIERA ER16 ESAGONALE	2
INS.DIG.ER20.EX	PER GHIERA ER20 ESAGONALE	2
INS.DIG.ER25	PER GHIERA ER25 STANDARD	3
INS.DIG.ER32	PER GHIERA ER32 STANDARD	3
INS.DIG.ER40	PER GHIERA ER40 STANDARD	3
INS.DIG.ER32NF	PER GHIERA ER32 SENZA TACCHE	4

RIDUZIONE CONO MORSE

CONO MORSE ADAPTERS



RIDUZIONI A CONO MORSE
CONO MORSE ADAPTERS



BUSSOLE DI RIDUZIONI A
CONO MORSE
MORSE TAPER SLEEVES



PORTA PINZE CON ATTACCO CONO MORSE - MORSE TAPER COLLET CHUCK - CM1

.Cod	TYPE	H	Ø D1
CM1.25.ER11M	CM1 H25 ERX11M	25	16
CM1.40.ER16M	CM1 H40 ERX16M	40	22



PORTA PINZE CON ATTACCO CONO MORSE - MORSE TAPER COLLET CHUCK - CM1

.Cod	TYPE	H	Ø D1
CM1.25.ER11	CM1 H25 ERX11	25	19
CM1.40.ER16	CM1 H40 ERX16	40	28



PORTA PINZE CON ATTACCO CONO MORSE - MORSE TAPER COLLET CHUCK - CM2

.Cod	TYPE	H	Ø D1
CM2.42.ER16M	CM2 H42 ERX16M	42	22
CM2.50.ER20M	CM2 H50 ERX20M	50	28
CM2.54.ER25M	CM2 H54 ERX25M	54	35



PORTA PINZE CON ATTACCO CONO MORSE - MORSE TAPER COLLET CHUCK - CM2

.Cod	TYPE	H	Ø D1
CM2.62.ER32.DX	CM2 H62 ERX32 DX M30x1,5	62	50
CM2.62.ER32.SX	CM2 H62 ERX32 SX M30x1,5	62	50
CM2.85.ER32.DX	CM2 H85 ERX32 DX M20x14	85	50
CM2.85.ER32.SX	CM2 H85 ERX32 SX M20x14	85	50
CM2.93.ER40.1.DX	CM2 H93 ERX40 DX M30x1,5	93	63
CM2.93.ER40.1.SX	CM2 H93 ERX40 SX M30x1,5	93	63
CM2.93.ER40.2.DX	CM2 H93 ERX40 DX M20x14	93	63
CM2.93.ER40.2.SX	CM2 H93 ERX40 SX M20x14	93	63Z



PORTA PINZE CON ATTACCO CONO MORSE - MORSE TAPER COLLET CHUCK - CM2

.Cod	TYPE	H	Ø D1
CM2.42.ER16	CM2 H42 ERX16	42	28
CM2.50.ER20	CM2 H50 ERX20	50	34
CM2.54.ER25	CM2 H54 ERX25	54	42



PORTA PINZE CON ATTACCO CONO MORSE - MORSE TAPER COLLET CHUCK - CM3

.Cod	TYPE	H	Ø D1
CM3.43.ER16M	CM3 H43 ERX16M	43	22
CM3.47.ER20M	CM3 H47 ERX20M	47	28
CM3.58.ER25M	CM3 H58 ERX25M	58	35



PORTA PINZE CON ATTACCO CONO MORSE - MORSE TAPER COLLET CHUCK - CM3

.Cod	TYPE	H	Ø D1
CM3.70.ER32.DX	CM3 H70 ERX32 DX M30x1,5	70	50
CM3.70.ER32.SX	CM3 H70 ERX32 SX M30x1,5	70	50
CM3.80.ER40.DX	CM3 H80 ERX40 DX M30x1,5	80	63
CM3.80.ER40.SX	CM3 H80 ERX40 SX M30x1,5	80	63



PORTA PINZE CON ATTACCO CONO MORSE - MORSE TAPER COLLET CHUCK - CM3

.Cod	TYPE	H	Ø D1
CM3.53.ER25	CM3 H53 ERX25	53	42
CM3.70.ER32	CM3 H70 ERX32	70	50
CM3.80.ER40	CM3 H80 ERX40	80	63



PORTA PINZE CON ATTACCO CONO MORSE - MORSE TAPER COLLET CHUCK - CM4

.Cod	TYPE	H	Ø D1
CM4.56.ER25	CM4 H56 ERX25	56	42
CM4.60.ER32	CM4 H60 ERX32	60	50
CM4.81.ER40	CM4 H81 ERX40	81	63
CM4.96.ER50	CM4 H96 ERX50	96	78



PORTA PINZE CON ATTACCO CONO MORSE - MORSE TAPER COLLET CHUCK - CM5

.Cod	TYPE	H	Ø D1
CM5.50.ER32	CM5 H50 ERX32	50	50
CM5.82.ER40	CM5 H82 ERX40	82	63
CM5.91.ER50	CM5 H91 ERX50	91	78



BUSSOLA DI RIDUZIONE A CONO MORSE - MORSE TAPER SLEEVES- CM2

.Cod	TYPE	L
CM2-1	CM2 - CM1	92



BUSSOLA DI RIDUZIONE A CONO MORSE - MORSE TAPER SLEEVES- CM3

.Cod	TYPE	L
CM3-1	CM3 - CM1	99
CM3-2	CM3 - CM2	112



BUSSOLA DI RIDUZIONE A CONO MORSE - MORSE TAPER SLEEVES- CM4

.Cod	TYPE	L
CM4-1	CM4 - CM1	124
CM4-2	CM4 - CM2	124
CM4-3	CM4 - CM3	140



BUSSOLA DI RIDUZIONE A CONO MORSE - MORSE TAPER SLEEVES- CM5

.Cod	TYPE	L
CM5-1	CM5 - CM1	156
CM5-2	CM5 - CM2	156
CM5-3	CM5 - CM3	156
CM5-4	CM5 - CM4	174



BUSSOLA DI RIDUZIONE A CONO MORSE - MORSE TAPER SLEEVES- CM6

.Cod	TYPE	L
CM6-4	CM6 - CM4	218
CM6-5	CM6 - CM5	218

WWW.SERINEX.IT

